



**INTEGRATED
FLUID POWER SOLUTIONS**

PRODUCT CATALOGUE

TABLE OF CONTENTS

THE WORLD OF GATES 10

Gates: Your one-stop-shop.....	12
Get working better with the Gates Integrated System Approach.....	14
Gates: Excellence, innovation and reliability built in	16
Safety First - Use Gates to help you	20
Protecting health - a Gates commitment to every customer.....	22
A strong Global Partner ... Yet always available to you	24

THE WORLD OF HOSE 26

Innovation: PolarFlex® MegaSys®	28
Hydraulic & Engine hose selection table.....	30
Industrial hose selection table.....	32

Hydraulic hose 34

Constant pressure	36
IA5600	36
ID5K	37
EFG6K	38
EFG5K	39
EFG4K	40
EFG3K	41
HD-UHP.....	42
M6K.....	43
M5K.....	44
M4K.....	45
M3K.....	46
To EN / SAE standard.....	47
CM2T.....	47
M2T.....	48
CM2TDL-XTF	49
G2.....	50
G1.....	51
TH8.....	52
TH7.....	53
TH7DL.....	54
G3H.....	55
GTH.....	56
GMV MegaVac®.....	57
Special high / low temperature	58
EFG6KL.....	58

EFG5KL.....	59
EFG4KL.....	60
M4KH.....	61
M4KL.....	62
M3KH.....	63
G2XH.....	64
G2H.....	65
G2L.....	66
G1H.....	67

Engine hose 68

SCR.....	70
Specifications and range.....	71
Coolant.....	72
Blue Stripe™.....	72
Coolant hose specifications	73
Fuel.....	74
4219BG Barricade® GreenShield®.....	74
4219BF Barricade® GreenShield®.....	75
4219G.....	76
Fuel hose specifications.....	77
Air intake.....	78
4171H.....	78
Air intake hose specifications	79
Hot oil lines	80
C5CXH.....	80
MegaTech®.....	81
Other hose specifications	82

Industrial hose 84

Explanation of the symbols used in this document.....	86
Cleaning hose.....	88
Water Blast.....	88
JetClean™ 2JC.....	89
JetClean™ 1JC.....	90
Clean Master™ Pressure Wash	91
Petroleum transfer	92
Premium™ Fuel Master D.....	92
Premium™ Fuel Master SD	93
Essential™ Oil Master SD	94
Essential™ Oil Master Lite SD	95
Essential™ Reel Master D.....	96
Essential™ Bunker Master D.....	97
Premium™ Tar Master SD	98

TABLE OF CONTENTS

INTEGRATED FLUID POWER SOLUTIONS

Steam hose.....	99	THE WORLD OF COUPLINGS	162
Premium™ Steam Master.....	99	Innovation: iLok™ coupling	164
Premium™ Steam Master Red	100	Coupling selection table.....	166
Premium™ Heater Master.....	101	Couplings for Wire Spiral Hydraulic Hoses	176
Acid-chemical	102	GlobalSpiral Maximum.....	178
Premium™ Chem Master XLPE SD.....	102	BSP FBSPORX	178
Premium™ Chem Master EPDM D.....	103	BSP FBSPORX45	178
Premium™ Chem Master EPDM SD	104	BSP FBSPORX90	178
Premium™ Chem Master UHMWPE SD.....	105	BSP MBSPP.....	179
Chem Master™ Xtreme™ FEP (125-200) SD	106	JIC 37° FJX.....	179
Chem Master™ Paint Spray.....	107	JIC 37° FJX45	179
Food & beverage	108	JIC 37° FJX90	180
Premium™ Dairy Master SD	108	JIC 37° MJ.....	180
Premium™ Dairy Master Lite SD.....	109	SAE FFORX	180
Premium™ Washdown Master	110	SAE FFORX45.....	181
Premium™ Milk Master SD	111	SAE FFORX90.....	181
Premium™ Beverage Master D	112	SAE FL	181
Water & air // Multipurpose	113	SAE FL45	182
Essential™ Water Master D	113	SAE FL90	182
Essential™ Water Master SD	114	SAE FLHCFM.....	182
GP80 Plus	115	SAE FLHCFM45	183
Lock-On Plus.....	116	SAE FLHCFM90	183
Premium™ GP Master	118	SAE FLH.....	183
GP60.....	119	SAE FLH22.....	184
Premium™ Multi Master.....	120	SAE FLH30.....	184
Plant Master™ Xtreme™ 250	121	SAE FLH45.....	184
Plant Master™ 200 / 250 Black.....	122	SAE FLH60.....	185
GP40.....	123	SAE FLH90.....	185
Air Master™ Diving Umbilical.....	124	FLC.....	186
Material handling	125	FLC22.....	186
Essential™ Sandblast Master D	125	FLC30.....	187
Essential™ Cement Master D.....	126	FLC45.....	187
Essential™ Cement Master SD.....	127	FLC90.....	188
Essential™ Silo Master D - food	128	DIN 24° FDHORX	188
Essential™ Silo Master SD - food.....	129	DIN 24° FDHORX45	188
Essential™ Concrete Master D.....	130	DIN 24° FDHORX90	189
Oilfield products.....	131	NPTF MP.....	189
Rotary hose overview.....	131	PLSOR.....	190
Large diameter MegaSpiral™		iLOK™ FILOR	190
hose assemblies.....	133	iLOK™ MILX	190
Chemical resistance table.....	134	PLSOR to iLOK™.....	191
		iCL.....	191
		GlobalSpiral	192
		NO-SKIVE FERRULES	192
		BSP FBSPORX	193
		BSP FBSPORX45	193

BSP FBSPORX90	194
BSP MBSPP	194
JIC 37° FJX	195
JIC 37° FJX45	196
JIC 37° FJX90S	196
JIC 37° FJX90M	197
JIC 37° FJX90L	197
JIC 37° MJ	198
JIS FKX	198
SAE FFORX	199
SAE FFORX45	200
SAE FFORX90S	200
SAE FFORX90M	201
SAE FFORX90L	201
SAE MFFOR	202
SAE FL	202
SAE FL22	203
SAE FL30	203
SAE FL45	204
SAE FL60	204
SAE FL67	205
SAE FL90S	205
SAE FL90M	206
SAE FL90L	207
SAE FLH	207
SAE FLH22	208
SAE FLH30	208
SAE FLH45	209
SAE FLH60	209
SAE FLH90S	210
SAE FLH90M	210
SAE FLH90L	211
FLK	211
FLK45	211
FLK90	212
FLC	212
FLC22	213
FLC30	213
FLC45	214
FLC60	214
FLC67	215
FLC90	215
DIN 24° FDLORX	216
DIN 24° FDLORX45	216
DIN 24° FDLORX90	217
DIN 24° MDL	217
DIN 24° FDHORX	218
DIN 24° FDHORX45	218
DIN 24° FDHORX90	219
DIN 24° MDH	219

NPTF MP	220
UNF MB	220
FG FFGX	221
FG FFGX90	221
FG MFG	221
FG FPFL	222
FG MPFL	222
FG MPFL90	223
KOBELCO MKB	223
HLE	224
HLE 90	224

Couplings for Wire and Textile Braided Hoses 226

GlobalSpiral Plus 228

NO-SKIVE FERRULES	228
BSP FBSPORX	228
BSP FBSPORX45	228
BSP FBSPORX90	229
BSP MBSPP	229
JIC 37° FJX	229
JIC 37° FJX45	230
JIC 37° FJX90	230
JIC 37° MJ	230
SAE FFORX	231
SAE FL	231
SAE FL30	231
SAE FL45	232
SAE FL60	232
SAE FL90	232
DIN 24° FDLORX	233
DIN 24° FDLORX45	233
DIN 24° FDLORX90	233
DIN 24° MDL	234
DIN 24° FDHORX	234
DIN 24° FDHORX45	234
DIN 24° FDHORX90	235
NPTF MP	235

MegaCrimp® 236

BSP MBSPT	236
BSP FBSPORX	237
BSP FBSPORX45	238
BSP FBSPORX90	239
BSP FBSPORX90BL	240
BSP MBSPP	241
BSP MBSPPBKHD	241
BSP FBFFX	242
BSP BSPBJ	242
JIC 37° FJX	243
JIC 37° FJX45	244

TABLE OF CONTENTS

INTEGRATED FLUID POWER SOLUTIONS

JIC 37° FJX90S	245	FG FFGX45	278
JIC 37° FJX90M	246	FG FFGX90	279
JIC 37° FJX90L	247	FG MFG	279
JIC 37° MJ	248	PL	280
JIS FJISX	249	AV	280
JIS FKX	249	POWERWASH FPWX	281
SAE FFORX	250	POWERWASH PWSP	281
SAE FFORX45	251	MQLH	282
SAE FFORX90S	252	MQLH45	282
SAE FFORX90M	253	MQLH90	283
SAE FFORX90L	254	FQLH	283
SAE MFFOR	255		
SAE 45° FSX	255	Couplings for Wire Spiral Blasting Hoses	284
SAE 45° FSX45	256		
SAE 45° FSX90	256	WaterBlast	286
SAE 45° MS	257	SKIVE FERRULES	286
SAE 45° MIX	257	BSP FBSPORX	286
SAE 45° MIX45	258	DIN 24° FDHORX	287
SAE 45° MIX90	258	NPTF MP	287
SAE 24° MFA	259		
SAE FL	259	Couplings for Push-On Textile Hoses	288
SAE FL22	260		
SAE FL30	260	Lock-on	290
SAE FL45	261	BSP FBSPPX	290
SAE FL60	261	BSP FBSPPX90	290
SAE FL90	262	BSP MBSP	291
FLK	263	JIC 37° FJX	291
FLK45	263	DIN 24° / 60° FDLX	292
FLK90	263	DIN 24° / 60° FDLX90	292
DIN 24° FDLORX	264	METRIC MSP	293
DIN 24° FDLORX45	265	METRIC DBJ	293
DIN 24° FDLORX90	266	NPTF MP	293
DIN 24° MDL	267		
DIN 24° FDHORX	268	Accessories	294
DIN 24° FDHORX45	269		
DIN 24° FDHORX90	270	Flange kits	296
DIN 24° MDH	271	SAE PA-FL flange kit	296
METRIC MSP	271	SAE PH-FLH flange kit	296
METRIC DBJ	272	SAE PH-FLH monobloc kit	297
NPTF FPX	273		
NPTF MP	273		
NPTF MPLN	274		
NPTF FP	274		
NPTF MPX	275		
NPTF MPX90	275		
UNF MB	276		
UNF MBX	276		
UNF MBX45	277		
UNF MBX90	277		
FG FFGX	278		

THE WORLD OF ADAPTORS 298

Innovation: Gates hydraulic adaptors.....	300
Adaptor selection table	302
Explanations.....	306

BSP adaptors 308

BSP MBSPP-MBSPP EQUAL.....	310
BSP MBSPP-MBSPP UNEQUAL	311
BSP MBSPP-MBSPPWD.....	312
BSP MBSPP-MBSPPBKHD	313
BSP MBSPP-MBSPT.....	314
BSP MBSPP-MB	315
BSP MBSPP-MM	316
BSP MBSPP-MP.....	317
BSP MBSPP-FBSPPX	318
BSP FBSPPX-FBSPPX	319
BSP FBSPP-FBSPP	320
BSP MBSPP-MBSPP90BL.....	320
BSP MBSPP-FBSPPX45BL.....	321
BSP MBSPP-FBSPPX90BL.....	321
BSP FBSPPX-FBSPPX90BL.....	322
BSP MBSPP-FBSPPX90SWT	322
BSP FBSPPX-FBSPPX90SWT	323
BSP MBSPP-MBSPP-MBSPP	323
BSP MBSPP-FBSPPX-MBSPP	324
BSP MBSPP-MBSPP-FBSPPX	324
BSP FBSPPX-FBSPPX-FBSPPX	325
BSP MBSPP-FBSPPX-FBSPPX.....	325
BSP FBSPPX-FBSPPX-MBSPP	326
BSP MBSPP-PLUG.....	326
BSP FBSPPX-CAP	327

JIC adaptors 328

JIC MJ-MMOR	330
JIC MJ-MMAOR90	330
JIC MJ-MMCOR.....	331
JIC MJ-MMACOR90.....	331
JIC MJ-MBSPPCOR.....	332
JIC MJ-MBSPPWD	333
JIC MJ-MBSPPACOR90.....	334
JIC MJ-MBSPPACOR45.....	335
JIC MJ-MJ-MBSPPACOR.....	336
JIC MJ-MBSPPACOR-MJ	336
JIC MJ-MB	337
JIC MJ-MBA90.....	338
JIC MJ-MBA45.....	338
JIC MJ-MJ-MBA.....	339

JIC MJ-MBA-MJ	339
JIC MJ-MJ.....	340
JIC MJ-MJ90.....	340
JIC MJ-MJ-MJ	341
JIC MJ-MJBKHD	341
JIC MJ-MJBKHD90	342
JIC MJ-MJBKHD45	342
JIC MJ-FJX90	343
JIC MJ-FJX45	343
JIC MJ-MJ-FJX	344
JIC MJ-FJX-MJ	344
JIC FJX-MBSPPCOR.....	345
JIC MJ-MP	346
JIC MJ-MP90	346
JIC FJ-CAP	347
JIC MJ-PLUG	347
JIC FJ-NUT.....	348
JIC TS METRIC.....	348
JIC TS IMPERIAL	349
JIC FJX-MJ	349

QLH adaptors 350

BSP MBSPP-FQLH.....	352
BSP MBSPPBKHD-FQLH	352
DIN MMOR-FQLH	353
SAE MB-FQLH	353

THE WORLD OF TUBE FITTINGS 354

Innovation: NanoProtect™	356
Tube fittings selection table	358

Pipe Screw Joints 366**A Male stud couplings 368**

A Male stud coupling BSP.....	368
A Male stud coupling metric.....	370
A Male stud coupling BSP WD.....	371
A Male stud coupling metric WD	372
A Male stud coupling NPT.....	373
AP Male stud couplings BSP taper.....	374
A Male stud coupling metric O-ring	375
A Male stud coupling UNF/UN O-ring	376

B Male stud elbows 377

B Male stud elbow BSP taper	377
B Male stud elbow metric taper	378
B Male stud elbow NPT.....	379

TABLE OF CONTENTS

INTEGRATED FLUID POWER SOLUTIONS

C Male stud branch tees	380	SGE T swiveling screw fitting high pressure metric DKA.....	414
C Male stud branch tee BSP taper	380	SGE T swiveling screw fitting high pressure metric EDE.....	415
C Male stud branch tee metric taper	381		
C Male stud branch tee NPT.....	382		
D Male stud run tees	383	Adjustable coupling	416
D Male stud run tee BSP taper	383	VB Adjustable elbow.....	416
D Male stud run tee metric taper	384	VC Adjustable branch tee	417
D Male stud run tee NPT.....	385	VD Adjustable barrel tee	418
E Straight couplings	386	VBDKO Adjustable male stud elbow.....	419
ER Straight reducing couplings	387	BFDKO Adjustable 45° elbow	421
F Equal elbows	388	VCDKO Adjustable equal tee.....	421
G Equal tees	389	VDDKO Adjustable male stud tee-stud barrel	422
GR Tee reducers	390	Standpipe coupling	423
H Equal crosses	392	VA Stud standpipe coupling	423
K Straight bulkhead connections	393	VA Stud standpipe coupling BSP.....	423
L Bulkhead elbow connections	394	VA Stud standpipe coupling metric.....	424
N Welding bulkhead connections	395	VA Stud standpipe coupling NPT	425
V Welding bosses	396	VADKO Stud standpipe adaptor	426
BS Welding elbows	397	VADKO Stud standpipe adaptor BSP	426
Couplings	398	VADKO Stud standpipe adaptor metric.....	427
Banjo coupling	400	VADKO Stud standpipe adaptor NPT	428
SBD Banjo coupling	400	Straight coupling and reducer	429
SBD Banjo coupling BSP.....	400	EDKO Straight coupling taper.....	429
SBD Banjo coupling metric.....	401	EDKOR Straight reducer coupling taper	430
SBD Banjo coupling components BSP	402	Adjustable locknut coupling	432
SBD Banjo coupling components metric	403	BE Adjustable locknut elbow	432
SB Banjo coupling choke-free	404	BE Adjustable locknut elbow metric	432
SB Banjo coupling choke-free BSP	404	BE Adjustable locknut elbow UNF/UN	433
SB Banjo coupling choke-free metric	405	BE Adjustable locknut elbow BSP RR	434
SBE Banjo coupling high pressure	406	BE Adjustable locknut elbow metric RR.....	435
SBE Banjo coupling high pressure BSP DKA....	406	BFE Adjustable 45° locknut elbow	436
SBE Banjo coupling high pressure BSP EDE....	407	BFE Adjustable 45° locknut elbow metric	436
SBE Banjo coupling high pressure BSP KDE....	408	BFE Adjustable 45° locknut elbow UNF/UN	437
SBE Banjo coupling high pressure metric DKA...	409	BFE Adjustable 45° locknut elbow BSP RR.....	438
SBE Banjo coupling high pressure metric EDE ...	410	BFE Adjustable 45° locknut elbow metric RR ..	439
SBE Banjo coupling high pressure metric KDE...	411	CE Adjustable locknut branch tee	440
SGE T swiveling screw fitting high pressure ...	412	CE Adjustable locknut branch tee metric	440
SGE T swiveling screw fitting		CE Adjustable locknut branch tee UNF/UN	441
high pressure BSP DKA	412	CE Adjustable locknut branch tee BSP RR	442
SGE T swiveling screw fitting		CE Adjustable locknut branch tee metric RR...	443
high pressure BSP EDE.....	413	DE Adjustable locknut run tee	444
		DE Adjustable locknut run tee metric	444
		DE Adjustable locknut run tee UNF/UN	445
		DE Adjustable locknut run tee BSP RR	446
		DE Adjustable locknut run tee metric RR	447

Pipe connections	448	Sealing Ring	479
Gauge Couplings	450	DKA/DKAD Seal edge ring	479-480
O Gauge coupling BSP	450	DKI Seal edge ring for gauge coupling.....	481
VODKO Gauge coupling with taper	451	WD Captive seal.....	481
Female stud couplings	452	TR Sealing ring	482
Al Female stud coupling BSP	452	KDE Retaining ring.....	483
Al Female stud coupling metric.....	453	EDE Retaining ring	484
Reducing adaptors	454	VSH Support Sleeve.....	485
RI Reducing adaptor.....	454	Welding Nipple-Pipe Screw Joints	486
RI Reducing adaptor with captive seal	455	Welding nipples	488
Reducing connections	456	SNO Welding nipple with O-ring seal	488
RL Reducing connection	456	SNR Welding nipple reducer.....	489
RS Reducing connection	457	Welding type screw joints	490
RLDKO Reducing connection with taper	458	SNO-V Welding type screw joint	490
RSDKO Reducing connection with taper	459	SNO-A order example screw joint	491
Valves	460	Flare Couplings	492
Non-return valves with cone	462	ABO Flare connection parts	494
Non-return valves – Introduction.....	462	Flare connection parts	494
RD Non-return valves.....	463	ABO-A order example screw joint	496
RV Non-return valves BSP	464	Control System	498
RV Non-return valves metric	465	CST connect test system with pin lock 400 bar ...	500
RZ Non-return valves BSP.....	466	CST system introduction	500
RZ Non-return valves metric	467	CST connect test system with pin lock.....	501
RF Non-return valves	468	CST pressure gauge fitting with pin lock	501
RVS Inside parts non-return valves	468	CST test coupling for cutting ring connection E.....	502
Ball check valves	469	CST test coupling for cutting ring connection S.....	503
ARVA Ball check valves	469	CSH test coupling with screw lock 630 bar	504
ARVV Ball check valves	469	CSH system introduction	504
Single Parts	470	CSH test coupling with screw lock	505
Cutting Ring	472	CSH test coupling for cutting ring connection E.....	506
DS Cutting ring	472	CSH test coupling for cutting ring connection S.....	507
DSW Cutting ring.....	473	CSH direct gauge adaptor.....	508
Nut	474	CSH gauge adaptor	508
M Lock nut.....	474	CSH reducing fitting	509
UES Internal coupling nut.....	475	CSH bulkhead coupling A	509
GM Counter nut	475	CSH bulkhead coupling B	509
Plug	476	CSH thread type adaptor A	510
VSCH Blanking plug	476	CSH thread type adaptor B	510
VSCHK Standpipe end plug.....	477	CSH welding adaptor.....	510
STO Blanking plug.....	478	CSS test coupling with screw lock 630 bar	511
		CSS system introduction	511
		CSS test coupling with screw lock.....	512

TABLE OF CONTENTS

INTEGRATED FLUID POWER SOLUTIONS

CSS test coupling for cutting ring connection E.....	513
CSS test coupling for cutting ring connection S.....	514
CSS direct gauge adaptor	514
CSS gauge adaptor.....	515
CSS reducing fitting	515
CSS bulkhead coupling A.....	516
CSS bulkhead coupling B.....	516
CSS thread type adaptor A.....	517
CSS thread type adaptor B.....	517
CSS welding adaptor.....	517
CSHK test coupling with screw lock 630 bar	518
CSHK system introduction	518
CSHK test coupling with screw lock.....	519
CSHK test coupling for cutting ring connection E ...	520
CSHK test coupling for cutting ring connection S...	521
Pressure test kit.....	522
Pressure gauge	523
CMM pressure gauge.....	523
Adjustable gauge fitting	523
Hose connector	524
Hose order description	524
Hose connector	524
Hose fitting.....	525
Hose fitting for control system	525
Hose fitting type HS.....	525
Hose fitting type 12.....	525
Hose fitting type 0.....	525
Hose fitting type T connect.....	525
Hose fitting type M.....	526
Hose fitting type W.....	526
Hose fitting type N.....	526
Hose fitting type A	527
Hose fitting type S.....	527
Hose fitting type S90°.....	527
Hose fitting type K.....	528
Hose fitting type R.....	528
Hose fitting type L.....	528
Hose fitting type G	529
Hose fitting type F.....	529
Hose fitting type C	529
Hose fitting type J.....	530
Hose fitting type D	530
Hose fitting type Q	530
Hose fitting type B	531
Hose fitting type U	531
Hose fitting type UR.....	531
Hose fitting type E	532

Hose fitting type ER.....	532
Hose fitting type P	532
Hose fitting type H	533
Hose fitting type T.....	533
Hose fitting type V.....	533

THE WORLD OF ASSEMBLY MACHINERY 534

Innovation: EMB-FS® connection technology.... 536

Cutting Ring Assembly & Flaring Machinery 539

Opticam 34 Cutting Ring Assembly Machine	539
VM Pre-Assembly Bodies.....	540
UP/M Unipress Cutting Ring Assembly.....	541
UP 3 Unipress Cutting Ring Assembly & Flaring Machine	542

Tube End Forming & Tube Manipulation Machinery

FS 93 Tube Forming Machine	543
Mobilpress PB 642 Tube Bending Machine.....	545
RBV 6/18 Tube Bending Device.....	546

Cutting machines

Unicut TC 080 Metal Saw	547
MKX 40 Hose Cutter	548
MKX 30 Hose Cutter	549
MKX 25 Hose Cutter	550
MKX suction unit	550

Crimping machines

MCX 50	552
MCX 30	553
MCX 25	554
MCX 20	555
MC 1001	555

Die Selection Matrix.....

Accessories.....

Ancillaries.....

Optigrat OG 642 Tube Deburring Machine	559
TC 1036 S Uniclean Tube Rinsing Machine	559
MSX Hose Assembly Marking machine.....	560
Push-on tool.....	560
MegaCrimp® insertion tool.....	560
Hose perforator	561
Rotational table	561

THE WORLD OF GUARDS 562

Innovation: LifeGuard® Line-of-sight sleeving system	564
LifeGuard® 5000	566
HG Nylon Sleeve	568
Round steel spring guard	570
Flat armour guard	572
Thermoplastic armour guard	574

ENGINEERING AND TECHNICAL DATA 576

Selecting the correct hose 578

Hydraulic hose assembly and industrial hose selection criteria	578
Hose size selection nomogram	580
Material to be conveyed	581
Hydraulic system pressure drop	582

Selecting the correct coupling 584

Coupling selection criteria	584
Coupling identification	585
Easy identification of metric couplings	594
Coupling / adaptor thread identification	595
Thread size identification guide	596

Hose assembly selection and installation 600

Selecting the correct tube fitting 605

Gates-EMB DS Ring - characteristics	605
Gates-EMB DSW Ring - characteristics	605
Cutting ring fittings - assembly with VM adaptor	606
Cutting ring couplings - assembly	608
Adjustable couplings with Locknut - assembly	610
Gates-EMB cutting ring type pipe screw joints	611
Order code logic, delivery, and packaging	613
Stud threads and ports for pipe couplings	614
Tightening torques MA for studs	618
Pipes - dimensions and characteristics	619
Table for the application of reinforcing sleeves	620
Port connections and seals for test couplings	621
Test hoses technical data	622
Reducing couplings - examples	622
Welding nipple type screw joints - technique	624
Welding nipple type screw joints - assembly	624

Flare coupling DIN 24° - characteristics	625
Flare coupling DIN 24° - assembly	626
Flare coupling DIN 24° - tube dimension	628

Conversion tables..... 632

Product index 634

Warning 672

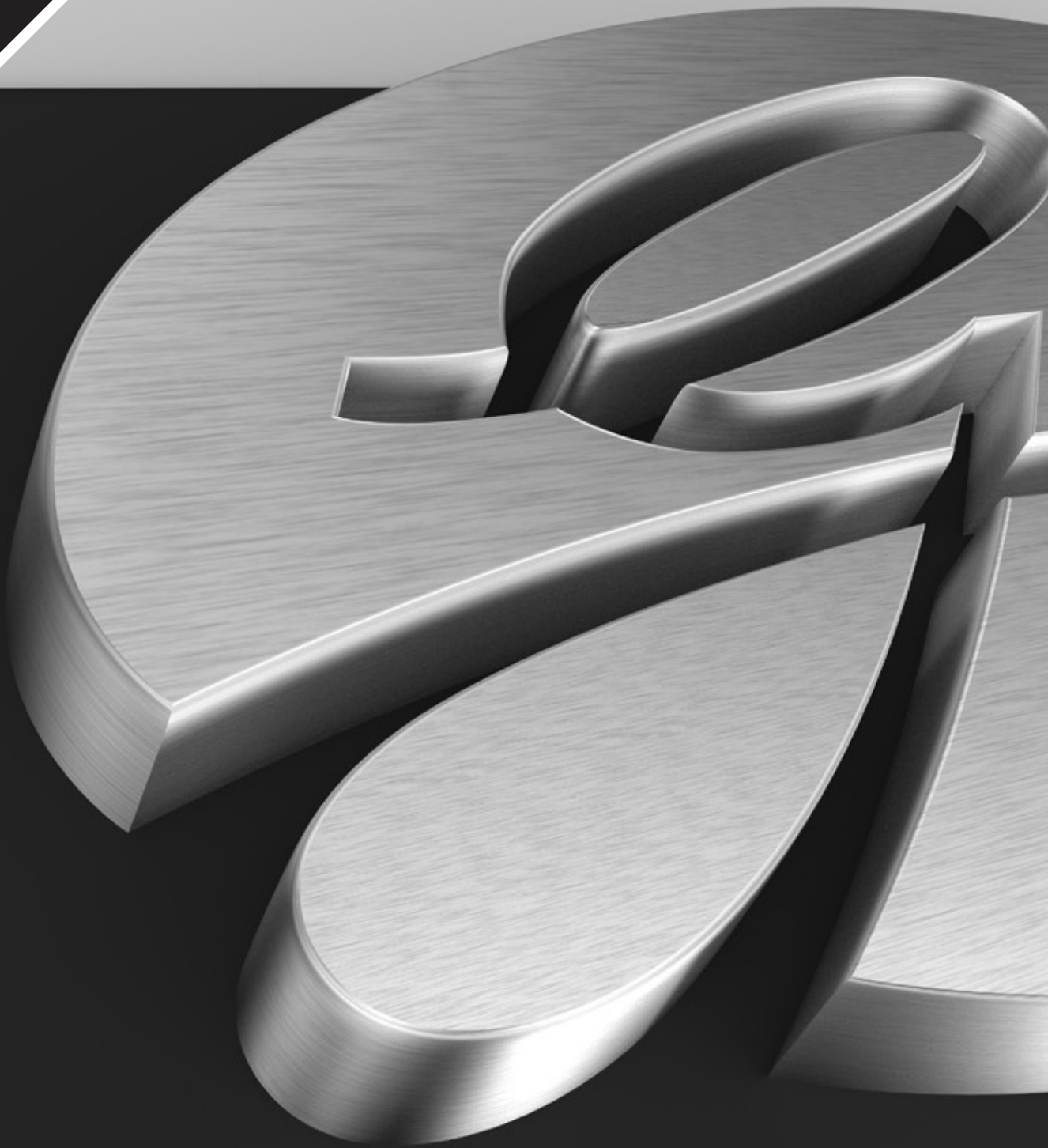

INTEGRATED FLUID POWER SOLUTIONS

THE WORLD OF GATES



GATES: YOUR ONE-STOP-SHOP

THE WORLD OF GATES



Every day, design engineers, maintenance people, equipment manufacturers and their customers around the world rely on Gates and our high quality line of hydraulics products to meet their fluid power needs and to keep them running smoothly, safely and reliably. Thanks to the Gates Integrated System Approach, all your fluid power products work together seamlessly.

With our global leadership position in hose assemblies, we have expanded our capabilities and tubing technology in port-to-port hydraulics:

- › **Rigid Tube Assemblies**
- › **Robotic Tube Bending & Welding**
- › **Integrated Hose/Tube combinations**
- › **Tube Fittings, End Forming & Adaptors**
- › **VEVA (Value Engineering Value Analysis) & Services**

And there are more opportunities to come!

Wherever you are, the state-of-the-art technology in our production locations and assembly centres allow us to support OEM's around the world with customised just-in-time solutions to meet their tight schedules, volumes and high expectations. We also offer replacement market customers the right equipment to manufacture factory-quality product assembly on their own premises and be the nearby go-to distributor with the right solution to every breakdown.

All Gates tube line, tubes fittings, hose and adaptor products are designed and manufactured to provide innovative, reliable port-to-port solutions in an almost endless range of heavy equipment applications.

Gates helps you to save time, space and money - without compromising on quality or safety

But we do not stop there. Based on our wide experience in hydraulics, hose development and leak-free hose/coupling interfaces, we have been expanding our product and market knowledge in other applications and systems over the last decades and we can now offer you Gates premium performance in industrial hoses, engine hoses and harsh roughneck oilfield applications alike.

In this catalogue, you will find more details about our complete offering and how our superior products can help you to:

- 1 Find the perfect solution**
- 2 Have peace of mind**
- 3 Save money, time and effort**
- 4 Be sure the future is taken care of**

The Gates service attitude is all about you: we help you keep costs down, make things easy to use, avoid downtime and loss of production, speed up installation, maintenance and repair – that's why people choose Gates.



GET WORKING BETTER WITH THE GATES INTEGRATED SYSTEM APPROACH

THE WORLD OF GATES



*Self-assembly the Gates way
saves you time and effort*

Only a team where everyone plays their part and works together seamlessly can get a complex job done. Our hose and coupling components work together in just the same way, making it extremely simple to create high-quality hydraulic hose assemblies quickly for the equipment you're using.

This kind of easy self-assembly is based on the Gates Integrated System approach. All our hydraulic products are specifically designed, tested and validated together to produce pre-tested and validated hose/coupling combinations that perform beyond any international standard.

This unique approach is how Gates ensures full compliance with the European Machinery Directive and the reason why Gates is known as the world's most trusted hydraulic hose assembly manufacturer. That is why Gates is your total fluid power solution.

THE GATES INTEGRATED SYSTEM APPROACH, HOW DOES IT WORK AND WHAT'S IN IT FOR YOU?



Superior products, manufactured to the stringent tolerances

Our global hoses and couplings not only boast a wide array of advanced-design features but are also manufactured to rigorous tolerances, making sure that they perform to such a high standard they'll work safely and properly for longer.
Benefit from less downtime.



Advanced self-assembly machines and dies, rigorously validated

Our self-assembly machines make it quick and easy for you to produce the hose and coupling combinations you need. Gates dies have a special proprietary profile design that creates an almost perfectly cylindrical and durable crimp. We test and validate them at our factory so you can be sure they'll work time after time in your workshop.
Increase the efficiency in your workshops.



CRIMP INFORMATION - INFORMACION DE DEBITEADO - PRESIONADO - INFORMATION PRESASADO - INFORMATION PRESASADO									
24 Jan 11									
Hose / Tapa: Schlauch / Tubo / Mangrove / Slang									
Hoisting / Entonar / Armar / Reunir / Conectar / Acoplar									
Machine / Machine / Máquina / Macchina / Magaria Machine									
Crimp Style / Tipo de Debitado / Al de Vengrado /									
Tipo Presionado / Tipo de Presado / 30° Edge									
Label base data / Datos de Datos Index / Nomencl. Acoplar / Datos de Datos Index /									
Puntos de datos Index / Datos de Datos									
Ref.	Ø	ØH	ØM	ØD	ØE	ØF	ØG	ØH	ØI
87104	10	12	10	0	30	0,30	0,0	0,0	24,0 - 25,0
87104	12	14	12	0	30	0,30	0,0	0,0	27,2 - 27,7
87104	14	16	14	0	30	0,30	0,0	0,0	30,0 - 30,8
87104	16	18	16	0	30	0,30	0,0	0,0	32,0 - 32,8
87104	18	20	18	0	37	0,37	0,0	0,0	34,0 - 34,7
87104	20	22	20	0	37	0,37	0,0	0,0	36,0 - 36,7

Optimal crimp data, derived from meticulous testing

Each Gates crimper comes with validated crimp settings data for the complete global hose and coupling product range. So there's no need for time consuming trial-and-error to find the ideal settings! You can even register to constantly stay up to date with the latest developments via mail or internet.
Set crimpers with the greatest of ease.



Factory-quality performance above and beyond international standards



Put all this together and you get the quality, performance and reliability that Gates is known for. When Gates Global hose and couplings are crimped in accordance with the Gates Integrated System, they yield factory-quality assemblies fully compliant to European Directives and legislation exceeding all international standards. Gates global wire-braid hose and MegaCrimp® coupling assemblies are developed to withstand more than 3 times international standards. Gates spiral wire hose and GlobalSpiral coupling assemblies will work beyond a million impulse cycles.
Trust Gates' exceptional performance and reliability.

**GATES: EXCELLENCE, INNOVATION
AND RELIABILITY BUILT IN**

THE WORLD OF GATES



*Whether you need components or complete assemblies,
the Gates option gives you a wide range of important benefits:*

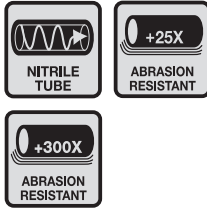

LONG-LASTING HOSES – THE BEST CHOICE FOR TOUGH CONDITIONS

Gates global hoses are designed for the harshest fluids and most abrasive environments. On the inside, the full nitrile inner tube resists even the most aggressive oils. On the outside, the tough standard hose covers give you unparalleled abrasion resistance. For the harshest conditions you can choose XtraTuff™ or MegaTuff™ covers to give you respectively 25x and 300x greater abrasion resistance.



SELECTION AND ASSEMBLY MADE EASY

No tooling needed to fit the coupling to the hose with the Gates global couplings and hoses, you can simply do it by hand. All our hoses and couplings are designed together – each with the other in mind. The Gates MegaCrimp® couplings and wire/textile-braid hoses are designed so that one ferrule fits the entire range for each respective construction. Our hoses and couplings carry logical part numbers to make identification simple and fast.



EASIER ROUTING WITH MORE COMPACT ASSEMBLIES

Gates global hoses are the ideal choice for tight, tortuous applications as they're designed to deliver their superior performance at incredibly tight bend radii and are manufactured to need minimal bending force.



HIGH- AND LOW-TEMPERATURE HOSES – DURABILITY AND FLEXIBILITY EVEN AT EXTREME TEMPERATURES

The Gates PolarFlex® programme uses advanced compounding technology for its hose tube and cover to bring the advantages of the MegaSys® and G2 hose ranges to arctic environments, thus ensuring extended service life, high abrasion resistance and flexibility at extremely low temperatures.

To meet the demands of modern compact engines Gates has developed a range of hoses that are at home in high and even extremely high-temperature environments, without compromising flexibility, performance or service life.

These high- and low-temperature hoses have been validated with the Gates MegaCrimp® and GlobalSpiral couplings.

GATES: EXCELLENCE, INNOVATION AND RELIABILITY BUILT IN

THE WORLD OF GATES



REDUCED DOWNTIME WITH GREASE-FREE SELF-ASSEMBLY MACHINES

Lower your maintenance costs by running grease-free with Gates self-assembly machinery. Our crimpers come with a unique, self-lubricating slide bearing system, which eliminates metal-to-metal abrasion between master dies and the crimper head and cuts friction by 20% in addition. This also means your working environment is cleaner which means you can benefit from reduced downtime too, bringing the total cost of ownership of Gates crimpers to a record low.

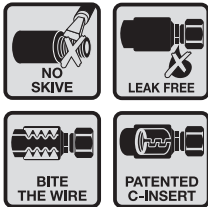

CLEANER, LEAK-FREE ASSEMBLIES THAT LAST LONGER

All of our hydraulic hose/coupling solutions are no-skive, so your assemblies don't risk contamination you can get with their skived counterparts. Additional benefits to no-skive assemblies are that they resist moisture better than skived ones and that easy assembly saves you time and money. You get the most secure, leak-free assembly money can buy because our MegaCrimp®'s advanced tooth profile bites the wire without compressing the hose's outer cover. In addition, the revolutionary patented MegaCrimp® c-insert makes sure exactly the right crimping force is applied giving you an evenly distributed cylindrical crimp. You get better flow, improved pressure and temperature resistance and, overall, a longer assembly lifetime.



QUALITY ABOVE AND BEYOND ANY GLOBAL STANDARD

Gates global wire-braid hose and MegaCrimp® coupling assemblies are able to withstand impulse testing to more than 3 times international standards. Gates global spiral wire hose and GlobalSpiral coupling assemblies will work safely beyond a million cycles. All of this means you get reliability built in as standard.

Gates solutions
keep you running
smoothly





CARING FOR THE ENVIRONMENT – SPECIAL NOTE

Gates strives to protect the environment in a variety of ways:

- › We encourage the use of alternative lubricants like synthetic and biodegradable oils with our hoses specially designed with nitrile inner tubes
- › Our grease-free self-assembly machinery helps create a clean working environment
- › We help eliminate the risk of system contamination no-skive hose/coupling solutions
- › Leak-free assemblies exclude environmental contamination
- › Our new generation of low-permeation fuel hoses cut fuel-vapour losses
- › The newly developed patented pressure, suction and return lines for Diesel Exhaust Fluid support SCR systems
- › All our products are REACH/RoHs/WEEE compliant

SAFETY FIRST – USE GATES TO HELP YOU

THE WORLD OF GATES

When working with hydraulic equipment, it's important to be aware of the potential dangers and never to underestimate the power of a hydraulic hose assembly under pressure. Having the world's best hoses and couplings is not enough to ensure the safety of your hose assemblies. Poor assembly, a bad installation or an incorrect method of storage can compromise performance and even safety.



THE GATES SAFE HYDRAULICS PROGRAMME: THINK SAFETY!

Your safety and that of your workforce, your customer and the environment is always a top priority for us. That's why we offer all our customers the Safe Hydraulics Programme, a safety and preventive maintenance training seminar.

The programme is designed by Gates application engineers and run by experienced and certified trainers. Our seminars can be tailored to match your needs, but most include the following topics:

- › How to work safely and how to reduce your risks and protect the environment
- › The entire safety process: storage, selection, installation and inspection
- › How to avoid material and personal hazards and liability issues
- › Expert information on safety issues affecting hydraulic hose assemblies

The seminar can accommodate people from all industries, backgrounds and levels of hydraulic knowledge. Book your place on a seminar through your authorised Gates distributor or partner.

To find out more please go to our website www.safehydraulicseurope.com or ask for our Safe Hydraulics pocket guide.

IMPORTANT FACTS TO TEST YOUR KNOWLEDGE ... DID YOU KNOW:

- › It's mandatory to mark hoses, showing the day and year of manufacture (ISO 4413:2010)?
- › The lifetime of hose assemblies is limited?
- › A burst hydraulic hose under pressure can result in serious injuries or even death?
- › The assembler can be held responsible for the consequences of a failed hydraulic hose assembly (2006/42/EC – ISO 4413:2010)?
- › You cannot mix and match components of different sources that are not validated nor tested (2006/42/EC – ISO 4413:2010)?
- › The repair of hose assemblies is forbidden by law (2006/42/EC – ISO 4413:2010)?





KEEPING YOU UP TO DATE WITH SAFETY AND LEGISLATION

In Europe the main safety Directive covering hose and machinery products is the European Machinery Directive 2006/42/EC. This provides the regulatory basis for the harmonisation of essential health and safety requirements for machinery at European Union level.

In practical terms, however, the best way to be sure you're complying with the Directive is to comply with the Harmonised European Standards. These standards are tools that help manufacturers and users comply with the Directive by giving you practical guidance on how to meet its requirements. The two most important standards on safety requirements for hydraulic hose assemblies are:

- > ISO 12100:2010 ('Safety of machinery: Basic concepts, general principles for design')
- > ISO 4413:2010 ('Safety of machinery – Safety requirements for fluid power systems and their components – Hydraulics')

The good news is that the Gates Integrated System of hoses, couplings, self-assembly machines and crimp data – used together – ensure you fully comply with this European Machinery Directive.

At Gates, safety is more than a priority - it's part of everything we do



PROTECTING HEALTH – A GATES COMMITMENT TO EVERY CUSTOMER

THE WORLD OF GATES



Gates complies with all the necessary legislation and regulations about the use of chemicals in the manufacturing process and their presence in finished goods. This section sets out our commitments and confirms that we comply fully with the relevant regulations for protecting human health and the environment.

REACH

The first is REACH – a European Community regulation [Regulation (EC) No. 1907/2006] on chemicals and their safe use. It stands for Registration, Evaluation, Authorisation and Restriction of Chemicals and its aim is to improve the protection of human health and the environment.

To control the use of chemicals and some of their possible hazardous effects, the European Commission set up the European Chemicals Agency (ECHA). All substances in our product portfolio that need to will be duly registered in the central ECHA database. And we will keep you properly informed about any changes to our products resulting from REACH and agree on any suitable measures on a case-by-case basis.

Also, as far as Article 33 of REACH is concerned, we would like to tell you the following:

All Gates products included in this catalogue, are free from any SVHC (Substance of Very High Concern).

We continue to exclude fully the use of any potential SVHCs in our products. Please refer to our website for the most up-to-date version of our REACH compliance letter and status:

www.Gates.com/europe/fpreach

ROHS AND WEEE

In addition to the notification information to improve visibility and tracking of hazardous chemicals in finished articles, the European Community has also defined a chemical and material blacklist. Its aim is to ban the use of specific substances or to ban the use of undesirable substances that might be part of a company's products and which have to be disposed of at the end of the product's life. Gates complies strictly with all these regulatory requirements.

The European ban also includes the use or the restricted presence of these chemicals within chemicals/ raw materials being used to manufacture products. The restricted substances with their maximum concentrations allowed are listed in the Annex II of the Directive 2011/65/EU.

For your information the maximum concentration values by weight in homogeneous materials for the restricted chemical substances are listed below:

Lead (Pb): $\leq 0.1\%$	Mercury (Hg): $\leq 0.1\%$	Cadmium (Cd): $\leq 0.01\%$
Hexavalent Chromium: $\leq 0.1\%$		
Polybrominated biphenyls (PBB) - flame retardant: $\leq 0.1\%$		
Polybrominated diphenyl ethers (PBDE) - flame retardant: $\leq 0.1\%$		

To help our customers comply with the Directive Gates declares that:

1. Gates itself does not knowingly or intentionally add any of the listed substances into any products it manufactures.
2. Gates, relying on signed declarations provided by its suppliers, verifies that the combination of chemicals/ raw materials used to manufacture its products shall not result in a Gates product that contains any of the listed substances in amounts that violate the above listed Directives.

DODD - FRANK WALL STREET REFORM AND CONSUMER PROTECTION ACT TITLE XV, SECTION 1502

A formal product assessment concluded that the SEC Conflict Minerals rule does not apply to Gates because there are no identified uses of Tantalum, Tungsten, Tin or Gold that are necessary to the functionality of or production of the products that Gates manufactures or contracts to manufacture. Based on purchasing policy, supplier selection process and information received from our major suppliers, we have no indication that Gates products contain minerals from conflict mines or smelters in and around the Democratic Republic of the Congo.

For ongoing compliance, Gates has initiated internal management programs that are aligned with the SEC requirements and the OECD Due Diligence Guidance for Responsible Supply Chains of Minerals from Conflict-affected and High Risk Areas.

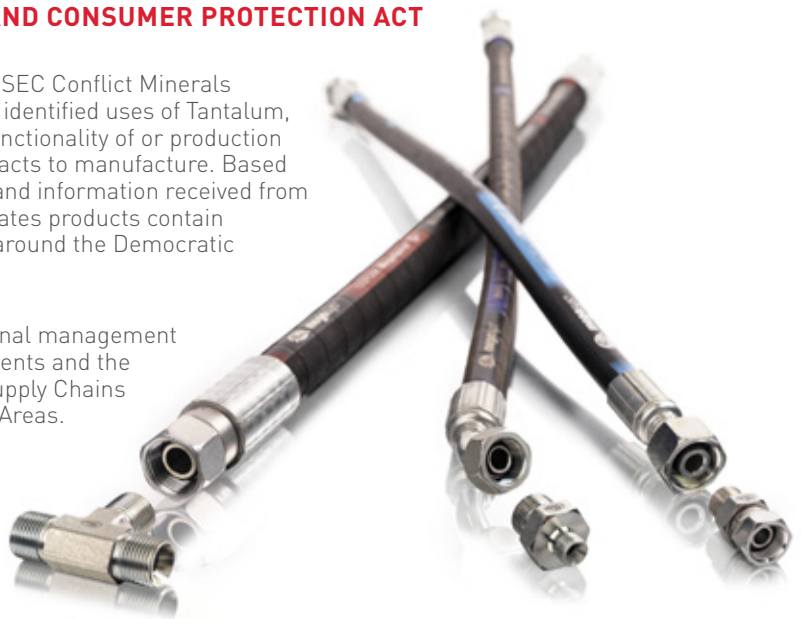

A STRONG GLOBAL PARTNER ... YET ALWAYS AVAILABLE TO YOU

THE WORLD OF GATES

From our modest beginnings in 1911 we have been powering progress and have grown into one of the world's largest manufacturers of original equipment and aftermarket industrial and automotive belts, hoses and hydraulic products, plus a host of related products.



We are present in all the world's major markets: we have manufacturing and sales operations in Europe, North America, Asia, Australia, South America and the Middle East. We use this global presence to deliver an unmatched range of products, services and support locally to you through our vast network of distributors.

When you buy Gates products, you get the best value for your money. The combination of engineering excellence with manufacturing expertise makes sure you get the best operational life and return on investment from the Gates equipment and components you use. Part of this service is to make the right information available at the right time, quickly and accurately. Thanks to Gates' presence on the web, you have all the information you need, right at your fingertips.

The Gates corporate website offers customers solutions to specific problems, and those are often industry or market specific. Consequently, Gates has broadly divided its corporate website into five industry classifications to match the way customers see their businesses:

- > **Energy, Exploration & Extraction**
- > **Infrastructure & Agriculture**
- > **Transportation**
- > **Automotive**
- > **Processing & Specialty**

Visitors who prefer searching Gates solutions by division and product line in the traditional way can do this by clicking on 'Products & Services'. Visit www.Gates.com/europe and go exploring!

Another convenient online service is the Gates-online e-commerce site www.Gates-online.com. Registered distributors can find the most current product information, check availability in real time and enter and track orders 24 hours/day.

With Gates, you benefit from the strength and expertise of a global manufacturer, the convenience of a nearby distribution network, local product support and useful online tools. A winning combination by any standards.

Fluid Power

- › Ghent: Distribution Centre
- › Moscow: Distribution Centre
- › Erembodegem: Gates European Headquarters
- › Karvina: Coupling Manufacturing
- › Karvina: Hose Assembly Manufacturing
- › Karvina: Manipulated Tube Manufacturing
- › St Neots: Hose Assembly Manufacturing
- › St Neots: Technical Center
- › Esch (EMB): Tube Fitting Manufacturing
- › Euskirchen (EMB): Technical Center
- › Sakarya: Hose Manufacturing

*Unparalleled performance –
in manufacturing, quality,
supply and support*





INTEGRATED FLUID POWER SOLUTIONS

THE WORLD OF HOSE



NOT JUST ANY LOW-TEMPERATURE HOSE

PolarFlex® MegaSys® is a specialised type of hose designed to work in frigid temperatures without stiffening or cracking of the hose covers and tubes. Cracking can cause the hose tube and body to separate with leaks and even premature failure as a result. PolarFlex® rubbers and hose assemblies remain flexible and allow articulation and reliable operation even in the brittle cold. The new PolarFlex® MegaSys® combines this peace of mind with all the advantages of the MegaSys® programme.



INNOV

MegaSys® hoses that stay flexible and durable down to -57°C and up to 420 bar



Cold weather operations demand a special breed of hose

Quality products mean reliable performance

During operations in arctic environments, hydraulic fluid goes from a cold sludge to a hot flow and that's why it's important that tube compounds tolerate extreme temperature swings and volumetric pressure changes. Standard hose tubes will absorb the hot hydraulic fluid, become spongy and crack. This could result in the release of particles damaging expensive hydraulic components such as pumps and valves. Not so the new PolarFlex® MegaSys® hoses.

In addition, regular steel couplings heat up fast when pressurised in cold weather conditions but PolarFlex® MegaSys® assemblies are designed to transmit heat evenly to a cold hose without damaging the connection.

Peace of mind in the coldest environments

With the introduction of the PolarFlex® MegaSys® hose, the MegaSys® product programme now also helps you to save time, space and money in extreme cold weather conditions.

- › Simple hose selection with constant pressure ratings
- › Easy hose identification in stock and in service
- › Shorter overall hose assembly length
 - M4KL: bends up to 50% of EN 853 2SN and PolarFlex® G2L
 - EFGxKL: bends up to 40% of EN 856
- › Easier plumbing and routing in tight applications
- › Fewer bent tube fittings
- › Extended lifetime in bending, flexing applications
- › Low inventory requirements



ATTENTION

HYDRAULIC & ENGINE HOSE SELECTION TABLE

THE WORLD OF HOSE

Hose type		Construction			Temperature °C	Size vs WP (MPa)													
		Tube ⁽¹⁾	Reinforcement	Cover ⁽¹⁾		-3	-4	-5	-6	-8	-10	-12	-14	-16	-18	-20	-22		
					5mm	6mm	8mm	10mm	13mm	16mm	19mm	22mm	25mm	28mm	32mm	35mm			
Constant pressure	IA5600	NBR	2 WB	NBR/PVC	-40/100				38.5										
	IDS5K	NBR	4 SW	CR	-40/121														
	EFG6K	NBR	4 SW & 6 SW	CR	-40/121				42.0	42.0	42.0	42.0	42.0	42.0	42.0	42.0	42.0	42.0	42.0
	EFG5K	NBR	4 SW & 6 SW	CR	-40/121				35.0	35.0	35.0	35.0	35.0	35.0	35.0	35.0	35.0	35.0	35.0
	EFG4K	NBR	4 SW	CR	-40/121				28.0	28.0	28.0	28.0	28.0	28.0	28.0	28.0	28.0	28.0	28.0
	EFG3K	NBR	4 SW	CR	-40/121														21.0
	HD-UHP	NBR	4 SW & 6 SW	CR	-40/121														
	M6K	NBR	2 WB	NBR/PVC	-40/100		42.0												
	M5K	NBR	2 WB	NBR/PVC	-40/100		35.0	35.0	35.0	35.0									
	M4K	NBR	2 WB	NBR/PVC	-40/100		28.0	28.0	28.0	28.0	28.0	28.0							
	M3K	NBR	1 WB & 2 WB	NBR/PVC	-40/100		22.5	22.5	22.5	22.5	22.5	22.5		22.5					
	Hydraulic hose To EN / SAE standard	CM2T	NBR	2 WB	SBR	-40/100		40.0	35.0	33.0	27.5	25.0	21.5		16.5				
M2T		NBR	2 WB	NBR	-40/100													15.9	
CM2TDL-XTF		NBR	2 WB	NBR	-40/100				33.0	27.5									
G2		NBR	2 WB	NBR/PVC	-40/100		40.0	35.0	33.0	27.5	25.0	21.5		16.5				12.5	
G1		NBR	1 WB	NBR/PVC	-40/100		22.5	21.5	18.0	16.0	13.0	10.5		9.0				6.4	
TH8		PA	2 FB	PU	-53/93		35.0		28.0	24.5		15.8		14.0					
TH7		PA	1 FB + 2YS	PU	-53/93		19.2	17.5	15.8	14.0		8.7		7.0					
TH7DL		PA	1 FB + 2YS	PU	-53/93		19.2	17.5	15.8	14.0									
G3H		NBR	2 FB	CR	-40/135		8.8		7.9	7.0	6.2	5.2		3.9				2.6	
GTH		NBR	1 FB	CR	-40/135		2.8	2.8	2.8	2.8	2.4	2.1		1.7					
GMV		NBR	1HSW + 1FB & 1HSW + 2YS	CR	-40/135							2.4		2.1					1.7
Special high / low temp		EFG6KL	NBR	4 SW	CR	-57/100				42.0		42.0		42.0					
	EFG5KL	NBR	4 SW	CR	-57/100				35.0	35.0	35.0	35.0	35.0	35.0	35.0	35.0	35.0	35.0	
	EFG4KL	NBR	4 SW	CR	-57/100				28.0	28.0	28.0	28.0	28.0	28.0	28.0	28.0	28.0	28.0	
	M4KH	NBR	2 WB	CR	-40/121		28.0		28.0	28.0	28.0	28.0							
	M4KL	NBR	2 WB	NBR/PVC	-57/100		28.0	28.0	28.0	28.0	28.0	28.0							
	M3KH	NBR	1 WB & 2WB	CR	-40/121		22.5	22.5	22.5	22.5	22.5	22.5		22.5					
	G2XH	CPE	2 WB	CSM	-40/150		42.0		35.0	29.0	25.0	21.5		17.5				15.5	
	G2H	NBR	2 WB	CSM	-40/135													12.5	
	G2L	NBR	2 WB	CR	-57/100		40.0		33.0	27.5	25.0	21.5		16.5				12.5	
	G1H	NBR	1 WB	CSM	-40/135		19.2		15.7	14.0	10.5	8.7		7.0				6.4	
	Engine hose	Blue Stripe™	EPDM	1 YS / 1 FB	EPDM	-40/150				0.4	0.5	0.4	0.3	0.5	0.3	0.9	0.7		
		4219BG	NBR	FB	NBR/PVC	-40/125	0.3	0.3	0.3	0.3	0.2								
4219BF		HNBR	FB	CPE	-40/135	1.5	1.5	1.5	1.5	1.5									
4219G		NBR	2 YS	NBR/PVC	-40/125	0.3	0.3	0.3	0.3	0.2	0.2	0.2							
4171H		VMQ	FB	VMQ	-40/288									1.4	1.4		1.4	1.4	
C5CXH		CPE	1 WB	TEXTILE	-40/150			20.7	15.5	13.8	12.1	10.3		5.5				4.3	
MegaTech®		CPE	1 WB	TEXTILE	-40/150		7.0		7.0	7.0	7.0	7.0		7.0				7.0	

Marine type approvals						
Hose type	DNV	GL	LR	BV	ABS	
EFG6K	✓	✓	✓	✓	✓	
EFG5K	✓	✓	✓	✓	✓	
EFG4K	✓	✓	✓	✓	✓	
EFG3K	✓	✓	✓	✓	✓	
M6K	✓	✓	✓	✓		
M5K	✓	✓	✓	✓		
M4K	✓	✓	✓	✓	✓	
M3K	✓	✓	✓	✓	✓	
CM2T	✓	✓	✓	✓		
M2T	✓				✓	
G2	✓	✓	✓	✓	✓	
G1	✓	✓	✓	✓	✓	

Size vs WP (MPa)																International standards			MTF	XTF	Twin	Page
-24	-28	-32	-36	-38	-40	-44	-48	-52	-54	-56	-60	-64	-72	-80	EN	SAE	ISO					
38mm	44mm	51mm	57mm	60mm	65mm	70mm	76mm	83mm	86mm	90mm	95mm	100mm	114mm	127mm								
																SAE 100R13	ISO 18752 AC				36	
																SAE 100R15	ISO 18752 DC // ISO 3862 R13				37	
	42.0	42.0														EN 856 R13	SAE 100R13	ISO 3862 R15	X			38
	35.0	35.0														EN 856 R12	SAE 100R12	ISO 3862 R13	X			39
																EN 856 R12	SAE 100R12	ISO 3862 R12	X			40
	21.0	21.0														EN 856 R12	SAE 100R12	ISO 3862 R12	X			41
																						42
																						43
																			X	X		44
																SAE 100R19	ISO 11237 R19	X	X		45	
																SAE 100R17	ISO 11237 R17	X	X		46	
															EN857 2SC	SAE 100R16	ISO 11237 2SC R16S	X		X	47	
	14.0	10.3													EN853 2SN	SAE 100R16 // SAE 100R2AT	ISO 11237 R16S // ISO 1436 2SN R2ATS				48	
															EN 857 2SC	SAE 100R16	ISO 11237 2SC R16S		X	X	49	
	9.0	8.0													EN 853 2SN	SAE 100R2AT	ISO 1436 2SN R2ATS				50	
	5.0	4.2													EN 853 1SN	SAE 100R1AT	ISO 1436 1SN R1ATS				51	
															EN 855 R8	SAE 100R8	ISO 3949 R8				52	
															EN 855 R7	SAE 100R7	ISO 3949 R7			X	53	
															EN 855 R7	SAE 100R7	ISO 3949 R7			X	54	
															EN 854 R3	SAE 100R3	ISO 4079 R3				55	
															EN 854 R6	SAE 100R6	ISO 4079 R6				56	
	1.1	0.8			0.5		0.4					0.4				SAE 100R4					57	
																SAE 100R15	ISO 3862 R15				58	
	35.0															SAE 100R13	ISO 3862 R13				59	
																SAE 100R12	ISO 3862 R12				60	
																SAE 100R19	ISO 11237 R19	X			61	
																SAE 100R19	ISO 11237 R19				62	
																SAE 100R17	ISO 11237 R17	X			63	
	12.4	10.3													EN 853 2SN	SAE 100R2AT	ISO 1436 2SN R2ATS				64	
	9.0	8.0													EN 853 2SN	SAE 100R2AT	ISO 1436 2SN R2ATS	X			65	
	9.0	8.0													EN 853 2SN	SAE 100R2AT	ISO 1436 2SN R2ATS				66	
	5.0	4.2														SAE 100R1					67	
	0.7	0.5	0.4	0.4												SAE 20R3 / R1 EC D-1					72	
																SAE 30R14 T1					74	
																SAE 30R14 T2					75	
																SAE 30R6 / 30R7					76	
	1.4	1.1	1.1	1.0	0.9	0.8	0.8	0.7	0.7	0.8	0.8	0.8	0.7	0.6							79	
																SAE 100R5 // 1405 // J1402					80	
	3.5	3.5			3.5		3.5									SAE J1405					81	

[1] Indicates main component of compound

[*] Application sign-off

Abbreviations	
FB	Fibre Braid
HSW	Helical Spiral Wire
SW	Spiral Wire
WB	Wire Braid
YS	Yarn Spiral

Abbreviation	Standard
ABS	American Bureau of Shipping
BV	Bureau Veritas
DNV	Det Norske Veritas (North Sea floating vessels)
GL	Germanischer Lloyd
LR	Lloyd's Register
MSHA	Mine Safety and Health Administration (US)





INDUSTRIAL HOSE SELECTION TABLE

THE WORLD OF HOSE

	HOSE TYPE	APPLICATION							TUBE (I)	DISCHARGE (D)/SUCTION & DISCHARGE (SD)	TEMPERATURE RANGE min./max. °C	SIZE VS WP (MPa)					
		AIR	CLEANING	WATER	OIL	CHEMICAL	STEAM	FOOD				ABRASION	6 mm	8 mm	10 mm	13 mm	16 mm
CLEANING	WATER BLAST		x						CR	SD	-20/70			100.0	100.0		
	JETCLEAN™ 2JC		x						NBR	SD	-40/155		40.0	40.0	40.0		
	JETCLEAN™ 1JC		x						NBR	SD	-40/155	20.0	20.0	20.0	20.0		
	CLEAN MASTER™ PRESSURE WASH 1WB		x						NBR	SD	-40/125		35.0	35.0	28.0		
	CLEAN MASTER™ PRESSURE WASH 2WB		x						NBR	SD	-40/125	24.0	25.0	21.0	17.5		
PETROLEUM TRANSFER	PREMIUM™ FUEL MASTER D			x	x				NBR	D	-30/90						2.0
	PREMIUM™ FUEL MASTER SD			x	x				NBR	SD	-30/90						1.6
	ESSENTIAL™ OIL MASTER SD			x	x				NBR	SD	-30/100						1.0
	ESSENTIAL™ OIL MASTER LITE SD			x	x				NBR	SD	-30/100						1.0
	ESSENTIAL™ REEL MASTER D			x	x				NBR	D	-30/70						
	ESSENTIAL™ BUNKER MASTER D			x	x				NBR	D	-30/90						
STEAM	PREMIUM™ TAR MASTER SD			x	x				NBR	SD	-30/160						
	PREMIUM™ STEAM MASTER			x			x		EPDM	D	-40/210				1.8	1.8	1.8
	PREMIUM™ STEAM MASTER RED			x			x		EPDM	D	-40/210				1.8	1.8	1.8
ACID-CHEMICAL	PREMIUM™ HEATER MASTER			x			x		EPDM	D	-20/164				0.6	0.6	0.6
	PREMIUM™ CHEM MASTER XLPE SD			x		x			XLPE	SD	-20/65						1.6
	PREMIUM™ CHEM MASTER EPDM D			x		x			EPDM	D	-40/95				1.6		1.6
	PREMIUM™ CHEM MASTER EPDM SD			x		x			EPDM	SD	-40/95						1.6
	PREMIUM™ CHEM MASTER UHMWPE SD	x		x		x			UHMWPE	SD	-20/65				1.6		1.6
	CHEM MASTER™ XTREME™ FEP SD			x		x			FEP	SD	-40/149						1.3
FOOD & BEVERAGES	CHEM MASTER™ PAINT SPRAY			x	x	x			PA11	D	-40/66	3.5	3.5	3.5	5.2		5.2
	PREMIUM™ DAIRY MASTER SD			x				x	NBR	SD	-30/90						
	PREMIUM™ DAIRY MASTER EPDM D			x				x	NBR	SD	-30/90						
	PREMIUM™ WASHDOWN MASTER			x			x		EPDM	D	-30/164			0.6	0.6	0.6	0.6
	PREMIUM™ MILK MASTER SD			x				x	NR	SD	-30/70						
	PREMIUM™ BEVERAGE MASTER D			x				x	CR/NR	D	-30/90				1.6		1.6
WATER & AIR	ESSENTIAL™ WATER MASTER D	x		x				x	EPDM	D	-35/80						
	ESSENTIAL™ WATER MASTER SD	x		x				x	EPDM	SD	-35/80						
	GP80 PLUS			x	x	x			NBR	D	-40/100	3.7	3.7	3.7	3.7	3.0	3.0
	LOCK-ON PLUS	x		x	x				NBR	D	-40/100	2.1		2.1	2.1	2.1	2.1
	PREMIUM™ GP MASTER	x		x	x				NBR	D	-40/95	2.5	2.5	2.5	2.5	2.5	2.5
	GP60			x	x	x			NBR	D	-40/100	2.0	2.0	2.0	2.0	2.0	2.0
	PREMIUM™ MULTI MASTER	x		x					EPDM	D	-40/100	2.0	2.0	2.0	2.0	2.0	2.0
	PLANT MASTER™ XTREME™ 250	x		x	x				NBR	D	-40/100	1.7		1.7	1.7	1.7	1.7
	PLANT MASTER® 200 / 250 BLACK	x		x					EPDM	D	-40/93	1.4		1.4	1.4	1.4	1.4
	GP40	x		x				x	EPDM	D	-40/100	1.3	1.3	1.3	1.3	1.3	1.3
MATERIAL HANDLING	AIR MASTER™ DIVING UMBILICAL	x							NBR	D	-40/49			7.8	6.9		
	ESSENTIAL™ SANDBLAST MASTER D			x				x	NR/BR	D	-40/75						1.2
	ESSENTIAL™ CEMENT MASTER D			x				x	NR/BR	D	-20/80						
	ESSENTIAL™ CEMENT MASTER SD			x				x	NR/BR	SD	-20/80						
	ESSENTIAL™ SILO MASTER D - FOOD			x				x	NR/BR	D	-20/80						
	ESSENTIAL™ SILO MASTER SD - FOOD			x				x	NR/BR	SD	-20/80						
	ESSENTIAL™ CONCRETE MASTER D			x				x	NR/BR/SBR	D	-20/70						4.0

The recommended applications have to be interpreted as guidelines only. In case of other specific applications, please contact your Gates industrial hose supplier.





EXPLANATION OF SYMBOLS

Hose bore	Hose outside diameter	Maximum working pressure	Minimum burst pressure
			

SIZE VS WP (MPa)																				STANDARDS & HOMOLOGATIONS	Page							
25 mm	32 mm	35 mm	38 mm	40 mm	45 mm	50 mm	51 mm	57 mm	63 mm	65 mm	70 mm	75 mm	76 mm	80 mm	90 mm	100 mm	102 mm	110 mm	125 mm			127 mm	152 mm	203 mm	254 mm			
																									88			
																									89			
																									90			
																									91			
																									91			
	2.0	2.0		2.0			2.0	2.0		2.0			2.0	2.0		2.0	2.0					2.0			EN 12115 . EN 1761	92		
	1.6	1.6		1.6			1.6	1.6		1.6			1.6	1.6		1.6	1.6				1.6	1.6			EN 12115 . EN 1761	93		
	1.0	1.0		1.0			1.0			1.0			1.0			1.0				1.0		1.0				94		
	1.0	1.0		1.0				1.0		1.0			1.0		1.0	1.0					1.0	1.0				95		
	1.6	1.6	1.6	1.6	1.6			1.6													1.6	1.6	1.6	1.6			96	
																										97		
	1.8	1.8		1.8				1.8		1.4			1.4													98		
	1.8	1.8		1.8				1.8																		99		
	1.8	1.8		1.8				1.8																		EN ISO 6134:2005-2A	99	
	1.8	1.8		1.8				1.8																		EN ISO 6134:2005-2A	100	
	0.6	0.6		0.6				0.6																		BS 5122/A2	101	
	1.6	1.6		1.6			1.6	1.6		1.6			1.6	1.6		1.6										102		
	1.6	1.6		1.6			1.6	1.6		1.6			1.6	1.6		1.6	1.6									EN 12115	103	
	1.6	1.6		1.6			1.6	1.6		1.6			1.6	1.6		1.6	1.6					1.6				EN 12115	104	
	1.6	1.6		1.6			1.6	1.6		1.6			1.6	1.6		1.6	1.6									EN 12115	105	
	1.3			1.3				1.3		1.3			1.3														106	
																											107	
		1.0		1.0	1.0	1.0		1.0		1.0			1.0			1.0										FDA, ADI-free	108	
		1.0		1.0	1.0	1.0		1.0		1.0			1.0			1.0										FDA, ADI-free	109	
	0.6	0.6		0.6				0.6																		FDA, ADI-free	110	
				0.6	0.6	0.6		0.6		0.6		0.6														FDA, ADI-free	111	
	1.6	1.6		1.6	1.6			1.6		1.6			1.6	1.6		1.6										FDA, ADI-free	112	
	1.0	1.0		1.0				1.0		1.0			1.0			1.0					1.0	1.0	1.0				113	
	1.0	1.0		1.0				1.0		1.0			1.0			1.0					1.0	1.0	1.0				114	
	3.0	3.0		3.0				3.0																			115	
																											116	
	2.5																										118	
	2.0																										119	
	2.0	2.0		2.0																							120	
	1.7	1.7		1.7																							121	
	1.4																										122	
	1.3	1.3		1.3																							123	
																											MIL-H-2815G Section 3.122	124
	1.2	1.2		1.2																							DIN 53516	125
								0.8		0.8			0.8	0.8	0.8		0.8	0.8									DIN 53516	126
								0.8		0.8			0.8	0.8	0.8		0.8	0.8				0.8	0.8	0.8			DIN 53516	127
								0.8		0.8			0.8	0.8	0.8		0.8	0.8									FDA	128
								0.8		0.8			0.8	0.8	0.8		0.8	0.8									FDA	129
	4.0	4.0	4.0	4.0			4.0			4.0																	DIN 53516	130

[1] Indicates the main component of the compound

EXPLANATION OF SYMBOLS

Minimum bend radius	Vacuum	Weight	Hose
			

THE WORLD OF HOSE
INTEGRATED FLUID POWER SOLUTIONS



HYDRAULIC HOSE



HYDRAULIC HOSE CONSTANT PRESSURE

THE WORLD OF HOSE

IA5600



↔		⊘		⌚		🌪️		📏		📊	
-size	DN	"	"	mm	PSI	MPa	PSI	MPa	mm	kg/100m	REF.
-6	10	3/8	0.69	17.5	5600	38.5	22400	154.0	65	41	6IA5600

RECOMMENDED FOR	High pressure hydraulic applications. Easy to route and to install in tight areas.
TUBE	NBR (Nitrile) based.
REINFORCEMENT	Two braids of high tensile steel wire.
COVER	NBR/PVC based.
TEMPERATURE RANGE	-40°C to +100°C constant and +121°C intermittent. For water emulsions, etc. see Temperature Limits Table.
STANDARDS	Exceeds ISO 18752 Type AC.
COUPLINGS	MegaCrimp®.
BENEFITS	70% of EN 857 2SC and 50% of EN 853 2SN bend radius at rated working pressure. Exceeding maximum working pressure requirements of EN 857 2SC. Exceeds impulse life performance of ISO 18752 Type AC @ 200.000 cycles. Lightweight.

HYDRAULIC HOSE CONSTANT PRESSURE

ID5K



↔		⊘		⌚		🔥		📏		📊	
-size	DN	"	"	mm	PSI	MPa	PSI	MPa	mm	kg/100m	REF.
-12	19	3/4	1.14	29.0	5000	35.0	20000	140.0	120	119	12ID5K
-16	25	1	1.45	36.8	5000	35.0	20000	140.0	150	199	16ID5K

- RECOMMENDED FOR** Extremely high pressure and high impulse hydraulic applications. Lightweight compact solution for optimal routing and energy efficiency.
- TUBE** NBR (Nitrile) based.
- REINFORCEMENT** Four alternating layers of spiralled, high tensile steel wire.
- COVER** CR (Chloroprene) based. MSHA approved.
- TEMPERATURE RANGE** -40°C to +121°C. For water emulsions, etc. see Temperature Limits Table.
- STANDARDS** Exceeds ISO 18752 Type DC. ISO 3862 R13. EN 856 R13. SAE 100R13.
- COUPLINGS** -12 to -16: GlobalSpiral Stem + GSID1F-4 Ferrule.
- BENEFITS** Up to 40% of EN 856 4SP bend radius at rated working pressure.
Exceeds impulse life performance of ISO 18752 type DC @ 1.000.000 impulse cycles.
Lightweight.

HYDRAULIC HOSE CONSTANT PRESSURE

THE WORLD OF HOSE

EFG6K

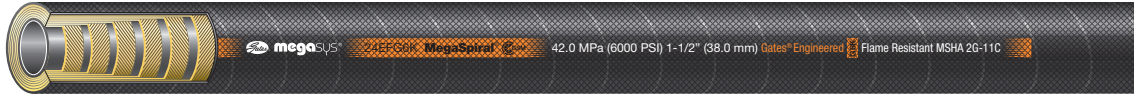

-size									mm	kg/100m	REF.
	DN	"	"	mm	PSI	MPa	PSI	MPa			
-6	10	3/8	0.80	20.2	6000	42.0	24000	168.0	65	71	6EFG6K
-8	12	1/2	0.95	24.0	6000	42.0	24000	168.0	90	89	8EFG6K
-10	16	5/8	1.09	27.6	6000	42.0	24000	168.0	100	115	10EFG6K
-12	19	3/4	1.24	31.4	6000	42.0	24000	168.0	120	144	12EFG6K
-16	25	1	1.53	38.7	6000	42.0	24000	168.0	150	223	16EFG6K
-20	31	1.1/4	1.97	50.0	6000	42.0	24000	168.0	210	399	20EFG6K
-24	38	1.1/2	2.26	57.4	6000	42.0	24000	168.0	250	482	24EFG6K
-32	51	2	2.80	71.1	6000	42.0	24000	168.0	635	719	32EFG6K

RECOMMENDED FOR

Extremely high pressure and high impulse hydraulic applications.

TUBE

NBR (Nitrile) based.

REINFORCEMENT

Four (six for -20 to -32) alternating layers of spiralled, high tensile steel wire.

COVER

CR (Chloroprene) based. MSHA approved.

TEMPERATURE RANGE

-40°C to +121°C. For water emulsions, etc. see Temperature Limits Table.

STANDARDS

Exceeds ISO 3862 R15. SAE 100R15.

COUPLINGS

-6 to -20: GlobalSpiral; -24, -32: GlobalSpiral Maximum.

TYPE APPROVALS

DNV, GL, LR, BV and ABS.

CHARACTERISTICS/BENEFITS

Up to 40% of EN 856 4SP/4SH bend radius at rated working pressure.

Extremely flexible.

Superior flex impulse performance: tested to 1,000,000 impulse cycles at 50% of SAE 100R15 bend radii (except -32).

Meets or exceeds performance requirements of EN 856 4SP (-8 to -32) and EN 856 4SH (-12 to -32).

EFG6K hose is compatible with biodegradable hydraulic fluids like synthetic esters, polyglycols and vegetable oils as well as petroleum-based fluids.

OPTIONAL



EFG6K-MTF: the complete range of EFG6K is also available with the Gates special MegaTuff™ cover which offers 300 times the abrasion resistance of the standard EFG6K cover as per ISO 6945, superior ozone and weathering resistance.



EFG6KL: for low-temperature applications, Gates recommends the EFG6KL range down to -57°C constant. Please refer to page 58.

IMPORTANT



Please consult Gates' Product Application Engineers for use of MegaTuff™ hose in reverse bending applications.



HYDRAULIC HOSE CONSTANT PRESSURE

EFG5K



↔		⊘		⌚		🌪️		📏		📊		📦
-size	DN	"	"	mm	PSI	MPa	PSI	MPa	mm	kg/100m	REF.	
-6	10	3/8	0.80	20.2	5000	35.0	20000	140.0	65	71	6EFG5K	
-8	12	1/2	0.95	24.0	5000	35.0	20000	140.0	90	89	8EFG5K	
-10	16	5/8	1.09	27.6	5000	35.0	20000	140.0	100	115	10EFG5K	
-12	19	3/4	1.24	31.4	5000	35.0	20000	140.0	120	144	12EFG5K	
-16	25	1	1.53	38.7	5000	35.0	20000	140.0	150	223	16EFG5K	
-20	31	1.1/4	1.97	50.0	5000	35.0	20000	140.0	210	399	20EFG5K	
-24	38	1.1/2	2.26	57.4	5000	35.0	20000	140.0	250	482	24EFG5K	
-32	51	2	2.80	71.1	5000	35.0	20000	140.0	635	719	32EFG5K	

- RECOMMENDED FOR** Extremely high pressure and high impulse hydraulic applications.
- TUBE** NBR (Nitrile) based.
- REINFORCEMENT** Four (six for -20 to -32) alternating layers of spiralled, high tensile steel wire.
- COVER** CR (Chloroprene) based. MSHA approved.
- TEMPERATURE RANGE** -40°C to +121°C. For water emulsions, etc. see Temperature Limits Table.
- STANDARDS** Exceeds ISO 3862 R13. EN 856 R13. SAE 100R13.
- COUPLINGS** -6 to -20: GlobalSpiral; -24, -32: GlobalSpiral Maximum.
- TYPE APPROVALS** DNV, GL, LR, BV and ABS.
- CHARACTERISTICS/BENEFITS** Up to 40% of EN 856 4SP/4SH bend radius at rated working pressure.
Extremely flexible.
Superior flex impulse performance: tested to 1,000,000 impulse cycles at 50% of EN 856 R13 and SAE 100R13 bend radii (except -32).
Meets or exceeds performance requirements of EN 856 4SP (-10 to -32) and EN 856 4SH (-20 to -32).
EFG5K hose is compatible with biodegradable hydraulic fluids like synthetic esters, polyglycols and vegetable oils as well as petroleum-based fluids.

- OPTIONAL**
-  EFG5K-MTF: the complete range of EFG5K is also available with the Gates special MegaTuff™ cover which offers 300 times the abrasion resistance of the standard EFG5K cover as per ISO 6945, superior ozone and weathering resistance.
 -  EFG5K-XTF: Sizes -6 up to -20 are also available with the Gates special XtraTuff™ cover which offers 25 times the abrasion resistance of the standard EFG5K cover as per ISO 6945.
 -  EFG5KL: for low-temperature applications, Gates recommends the EFG5KL range down to -57°C constant. Please refer to page 59.

IMPORTANT  Please consult Gates' Product Application Engineers for use of MegaTuff™ hose in reverse bending applications.

HYDRAULIC HOSE CONSTANT PRESSURE

THE WORLD OF HOSE

EFG4K

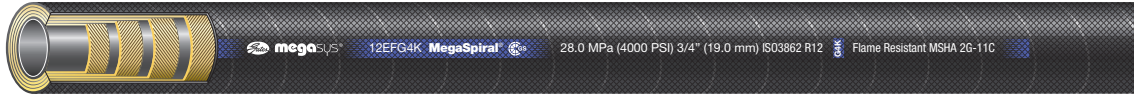

↔		⊘		⌚		🔥		📏		📊		📦
-size	DN	"	"	mm	PSI	MPa	PSI	MPa	mm	kg/100m	REF.	
-6	10	3/8	0.80	20.2	4000	28.0	16000	112.0	65	71	6EFG4K	
-8	12	1/2	0.95	24.0	4000	28.0	16000	112.0	90	89	8EFG4K	
-10	16	5/8	1.09	27.6	4000	28.0	16000	112.0	100	113	10EFG4K	
-12	19	3/4	1.21	30.7	4000	28.0	16000	112.0	120	128	12EFG4K	
-16	25	1	1.50	38.0	4000	28.0	16000	112.0	150	188	16EFG4K	
-20	31	1.1/4	1.85	47.0	4000	28.0	16000	112.0	210	283	20EFG4K	

- RECOMMENDED FOR** Extremely high pressure and high impulse hydraulic applications.
- TUBE** NBR (Nitrile) based.
- REINFORCEMENT** Four alternating layers of spiralled, high tensile steel wire.
- COVER** CR (Chloroprene) based. MSHA approved.
- TEMPERATURE RANGE** -40°C to +121°C. For water emulsions, etc. see Temperature Limits Table.
- STANDARDS** Exceeds ISO 3862 R12. EN 856 R12. SAE 100R12.
- COUPLINGS** GlobalSpiral.
- TYPE APPROVALS** DNV, GL, LR, BV and ABS.
- CHARACTERISTICS/BENEFITS** 40% of EN 856 4SP bend radius at rated working pressure.
Most flexible EN 856 R12 / SAE 100R12 hose in the industry.
Superior flex impulse performance: tested to 1,000,000 impulse cycles at 50% of EN 856 R12 and SAE 100R12 bend radii.
Meets or exceeds performance requirements of EN 856 4SP (-16, -20).
EFG4K hose is compatible with biodegradable hydraulic fluids like synthetic esters, polyglycols and vegetable oils as well as petroleum-based fluids.

OPTIONAL



EFG4K-MTF: the complete range of EFG4K is also available with the Gates special MegaTuff™ cover which offers 300 times the abrasion resistance of the standard EFG4K cover as per ISO 6945, superior ozone and weathering resistance.



EFG4K-XTF: the complete range of EFG4K is also available with the Gates special XtraTuff™ cover which offers 25 times the abrasion resistance of the standard EFG4K cover as per ISO 6945.



EFG4KL: for low-temperature applications, Gates recommends the EFG4KL range down to -57°C constant. Please refer to page 60.

IMPORTANT



Please consult Gates' Product Application Engineers for use of MegaTuff™ hose in reverse bending applications.

HYDRAULIC HOSE CONSTANT PRESSURE

EFG3K



-size	DN	"	"	mm	PSI	MPa	PSI	MPa	mm	kg/100m	REF.	
-20	31	1.1/4	1.85	47.0	3000	21.0	12000	84.0	210	282	20EFG3K	
-24	38	1.1/2	2.11	53.6	3000	21.0	12000	84.0	250	320	24EFG3K	
-32	51	2	2.63	66.8	3000	21.0	12000	84.0	635	439	32EFG3K	

RECOMMENDED FOR

Extremely high pressure and high impulse hydraulic applications.

TUBE

NBR (Nitrile) based.

REINFORCEMENT

Four alternating layers of spiralled, high tensile steel wire.

COVER

CR (Chloroprene) based. MSHA approved.

TEMPERATURE RANGE

-40°C to +121°C. For water emulsions, etc. see Temperature Limits Table.

STANDARDS

Exceeds ISO 3862 R12. EN 856 R12. SAE 100R12.

COUPLINGS

-20: GlobalSpiral; -24 to -32: GlobalSpiral Plus.

TYPE APPROVALS

DNV, GL, LR, BV and ABS.

CHARACTERISTICS/BENEFITS

Up to 40% of EN 856 4SP bend radius at rated working pressure.

Extremely flexible.

Superior flex impulse performance: tested to 1,000,000 impulse cycles at 50% of EN 856 R12 and SAE 100R12 bend radii (except -32).

Meets or exceeds performance requirements of EN 856 4SP.

EFG3K hose is compatible with biodegradable hydraulic fluids like synthetic esters, polyglycols and vegetable oils as well as petroleum-based fluids.

OPTIONAL



EFG3K-MTF: the complete range of EFG3K is also available with the Gates special MegaTuff™ cover which offers 300 times the abrasion resistance of the standard EFG3K cover as per ISO 6945, superior ozone and weathering resistance.

IMPORTANT



Please consult Gates' Product Application Engineers for use of MegaTuff™ hose in reverse bending applications.

HYDRAULIC HOSE CONSTANT PRESSURE

THE WORLD OF HOSE

HD-UHP



-size	↔		⊘		⌚		🔥		📏	📊	📦
	DN	"	"	mm	PSI	MPa	PSI	MPa	mm	kg/100m	REF.
-10	16	5/8	1.09	27.6	Application Sign-off		24000	168.0	100	115	10HD-UHP
-12	19	3/4	1.24	31.4			24000	168.0	120	144	12HD-UHP
-16	25	1	1.53	38.7			24000	168.0	150	223	16HD-UHP
-20	31	1.1/4	1.97	50.0			24000	168.0	210	399	20HD-UHP

- RECOMMENDED FOR** Extremely high pressure hydrostatic drive applications.
- TUBE** NBR (Nitrile) based.
- REINFORCEMENT** Four (six for -20) alternating layers of spiralled, high tensile steel wire.
- COVER** CR (Chloroprene) based. MSHA approved.
- TEMPERATURE RANGE** -40°C to +121°C. For water emulsions, etc. see Temperature Limits Table.
- STANDARDS** Gates proprietary.
- COUPLINGS** -10 to -20: GlobalSpiral.
- CHARACTERISTICS/BENEFITS** 40% of EN 856 4SP/4SH bend radius.
Extremely flexible.
HD-UHP hose is compatible with biodegradable hydraulic fluids like synthetic esters, polyglycols and vegetable oils as well as petroleum-based fluids.

IMPORTANT



Please consult Gates' Product Application Engineers for product application validation.

HYDRAULIC HOSE CONSTANT PRESSURE

M6K

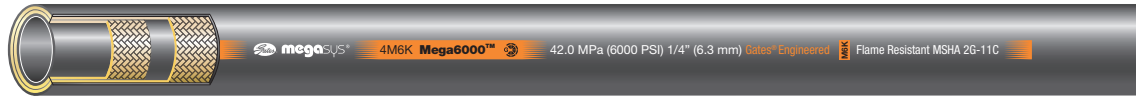

↔		⊘		⌚		🌸		📏		📊		📦
-size	DN	"	"	mm	PSI	MPa	PSI	MPa	mm	kg/100m	REF.	
-4	6	1/4	0.58	14.9	6000	42.0	24000	168.0	50	35	4M6K	

RECOMMENDED FOR	High pressure hydraulic applications. Easy to route and to install in tight areas.
TUBE	NBR (Nitrile) based.
REINFORCEMENT	Two braids of high tensile steel wire.
COVER	NBR/PVC based. MSHA approved.
TEMPERATURE RANGE	-40°C to +100°C constant and +121°C intermittent. For water emulsions, etc. see Temperature Limits Table.
STANDARDS	Gates proprietary.
COUPLINGS	MegaCrimp®.
TYPE APPROVALS	DNV, GL, LR and BV.
CHARACTERISTICS/BENEFITS	70% of EN 857 2SC and 50% of EN 853 2SN bend radius at rated working pressure. Superior flex impulse performance: tested to 600,000 impulse cycles. Meets or exceeds EN 857 2SC performance requirements. Lightweight. M6K hose is compatible with biodegradable hydraulic fluids like synthetic esters, polyglycols and vegetable oils as well as petroleum-based fluids.

IMPORTANT



Please consult Gates' Product Application Engineers for use of MegaTuff™ hose in reverse bending applications.

HYDRAULIC HOSE CONSTANT PRESSURE

THE WORLD OF HOSE

M5K

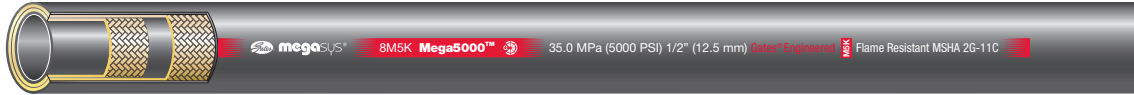

	-size	DN	"	mm	PSI	MPa	PSI	MPa	mm	kg/100m	REF.	
	-4	6	1/4	0.54	13.7	5000	35.0	20000	140.0	50	30	4M5K
	-5	8	5/16	0.61	15.4	5000	35.0	20000	140.0	55	34	5M5K
	-6	10	3/8	0.69	17.5	5000	35.0	20000	140.0	65	41	6M5K
	-8	12	1/2	0.86	21.9	5000	35.0	20000	140.0	90	66	8M5K

RECOMMENDED FOR	High pressure hydraulic applications. Easy to route and to install in tight areas.
TUBE	NBR (Nitrile) based.
REINFORCEMENT	Two braids of high tensile steel wire.
COVER	NBR/PVC based. MSHA approved.
TEMPERATURE RANGE	-40°C to +100°C constant and +121°C intermittent. For water emulsions, etc. see Temperature Limits Table.
STANDARDS	Gates proprietary.
COUPLINGS	MegaCrimp®.
TYPE APPROVALS	DNV, GL, LR and BV.
CHARACTERISTICS/BENEFITS	70% of EN 857 2SC and 50% of EN 857 2SN bend radius at rated working pressure. Superior flex impulse performance: tested to 600,000 impulse cycles. Meets or exceeds EN 857 2SC performance requirements. Lightweight. M5K hose is compatible with biodegradable hydraulic fluids like synthetic esters, polyglycols and vegetable oils as well as petroleum-based fluids.

OPTIONAL M5K-MTF: The complete range of M5K (except -5) is also available with the Gates special MegaTuff™ cover which offers 300 times the abrasion resistance of the standard M5K cover as per ISO 6945, superior ozone and weathering resistance.



M5K-XTF: the complete range of M5K is also available with the Gates special XtraTuff™ cover which offers 25 times the abrasion resistance of the standard M5K cover as per ISO 6945.

IMPORTANT



Please consult Gates' Product Application Engineers for use of MegaTuff™ hose in reverse bending applications.

HYDRAULIC HOSE CONSTANT PRESSURE

M4K

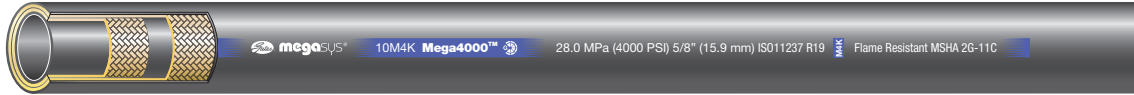

-size	↔		⊘		⌚		🔥		🔧	🏋️	📏
	DN	"	"	mm	PSI	MPa	PSI	MPa	mm	kg/100m	REF.
-4	6	1/4	0.54	13.7	4000	28.0	16000	112.0	40	33	4M4K
-5	8	5/16	0.61	15.4	4000	28.0	16000	112.0	45	34	5M4K
-6	10	3/8	0.69	17.5	4000	28.0	16000	112.0	50	46	6M4K
-8	12	1/2	0.82	20.8	4000	28.0	16000	112.0	70	51	8M4K
-10	16	5/8	0.98	25.0	4000	28.0	16000	112.0	75	74	10M4K
-12	19	3/4	1.15	29.1	4000	28.0	16000	112.0	95	93	12M4K

RECOMMENDED FOR

High pressure hydraulic applications. Easy to route and to install in extremely tight areas.

TUBE

NBR (Nitrile) based.

REINFORCEMENT

Two braids of high tensile steel wire.

COVER

NBR/PVC based. MSHA approved.

TEMPERATURE RANGE

-40°C to +100°C constant and +121°C intermittent. For water emulsions, etc. see Temperature Limits Table.

STANDARDS

Exceeds ISO 11237 R19. SAE 100R19.

COUPLINGS

MegaCrimp®.

TYPE APPROVALS

DNV, GL, LR, BV and ABS.

CHARACTERISTICS/BENEFITS

50% of EN 857 2SC and 40% of EN 857 2SN bend radius at rated working pressure.

Alternative to spiral hoses in high pressure lines where flexibility is required.

Superior flex impulse performance: tested to 600,000 impulse cycles.

Meets or exceeds EN 857 2SC performance requirements.

Lightweight.

M4K hose is compatible with biodegradable hydraulic fluids like synthetic esters, polyglycols and vegetable oils as well as petroleum-based fluids.

OPTIONAL



M4K-MTF: the complete range of M4K is also available with the Gates special MegaTuff™ cover which offers 300 times the abrasion resistance of the standard M4K cover as per ISO 6945, superior ozone and weathering resistance.



M4K-XTF: the complete range of M4K is also available with the Gates special XtraTuff™ cover which offers 25 times the abrasion resistance of the standard M4K cover as per ISO 6945.

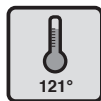

For high-temperature applications, Gates recommends the M4KH hose range up to +1 °C constant. Please refer to page 61.



M4KL: for low-temperature applications, Gates recommends the M4KL range down to -57°C constant. Please refer to page 62.

IMPORTANT



Please consult Gates' Product Application Engineers for use of MegaTuff™ hose in reverse bending applications.

HYDRAULIC HOSE CONSTANT PRESSURE

THE WORLD OF HOSE

M3K



-size	↔		⊘		⌚		🌊		📏	📊	📦
	DN	"	"	mm	PSI	MPa	PSI	MPa	mm	kg/100m	REF.
-4	6	1/4	0.48	12.2	3250	22.5	13000	90.0	40	17	4M3K
-5	8	5/16	0.59	15.1	3250	22.5	13000	90.0	45	26	5M3K
-6	10	3/8	0.63	16.0	3250	22.5	13000	90.0	50	28	6M3K
-8	12	1/2	0.80	20.2	3250	22.5	13000	90.0	70	41	8M3K
-10	16	5/8	0.99	25.2	3250	22.5	13000	90.0	75	73	10M3K
-12	19	3/4	1.14	29.0	3250	22.5	13000	90.0	95	91	12M3K
-16	25	1	1.48	37.7	3250	22.5	13000	90.0	115	155	16M3K

RECOMMENDED FOR

High pressure hydraulic applications. Easy to route and to install in extremely tight areas.

TUBE

NBR (Nitrile) based.

REINFORCEMENT

-4 to -8: one braid of high tensile steel wire; -10 to -16: two braids of high tensile steel wire.

COVER

NBR/PVC based. MSHA approved.

TEMPERATURE RANGE

-40°C to +100°C constant and +121°C intermittent. For water emulsions, etc. see Temperature Limits Table.

STANDARDS

Exceeds ISO 11237 R17. SAE 100R17.

COUPLINGS

MegaCrimp®.

TYPE APPROVALS

DNV, GL, LR, BV and ABS.

CHARACTERISTICS/BENEFITS

70% of EN 857 1SC/2SC and 50% of EN 853 1SN/2SN bend radius at rated working pressure.

Superior flex impulse performance: tested to 600,000 impulse cycles.

Exceeds working pressure requirements of R17.

Meets or exceeds EN 857 1SC/2SC performance requirements.

Lightweight.

M3K hose is compatible with biodegradable hydraulic fluids like synthetic esters, polyglycols and vegetable oils as well as petroleum-based fluids.

OPTIONAL



M3K-MTF: the complete range of M3K is also available with the Gates special MegaTuff™ cover which offers 300 times the abrasion resistance of the standard M3K cover as per ISO 6945, superior ozone and weathering resistance.



M3K-XTF: the complete range of M3K is also available with the Gates special XtraTuff™ cover which offers 25 times the abrasion resistance of the standard M3K cover as per ISO 6945.

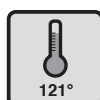

For high-temperature applications, Gates recommends the M3KH hose range up to +121°C constant. Please refer to page 63.

IMPORTANT



Please consult Gates' Product Application Engineers for use of MegaTuff™ hose in reverse bending applications.

HYDRAULIC HOSE TO EN / SAE STANDARD

CM2T

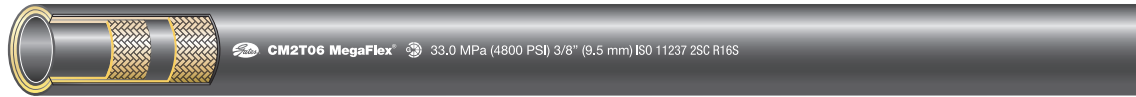

-size											REF.
	DN	"	"	mm	PSI	MPa	PSI	MPa	mm	kg/100m	
-4	6	1/4	0.55	14.1	5800	40.0	23200	160.0	50	31	CM2T04
-5	8	5/16	0.61	15.5	5000	35.0	20000	140.0	55	35	CM2T05
-6	10	3/8	0.70	17.7	4800	33.0	19200	132.0	65	42	CM2T06
-8	12	1/2	0.82	20.8	4000	27.5	16000	110.0	90	51	CM2T08
-10	16	5/8	0.97	24.6	3625	25.0	14500	100.0	100	70	CM2T10
-12	19	3/4	1.09	27.8	3100	21.5	12400	86.0	120	81	CM2T12
-16	25	1	1.41	35.8	2400	16.5	9600	66.0	150	115	CM2T16

RECOMMENDED FOR	High pressure hydraulic applications. Easy to route and to install in tight areas.
TUBE	NBR (Nitrile) based.
REINFORCEMENT	Two braids of high tensile steel wire.
COVER	SBR based.
TEMPERATURE RANGE	-40°C to +100°C constant and +121°C intermittent. For water emulsions, etc. see Temperature Limits Table.
STANDARDS	Exceeds ISO 11237 2SC R16S. EN 857 2SC. SAE 100R16.
COUPLINGS	MegaCrimp®.
TYPE APPROVALS	DNV, GL, LR and BV.
CHARACTERISTICS/BENEFITS	70% of EN 857 2SC bend radius at rated working pressure. Superior flex impulse performance. Lightweight. CM2T hose is compatible with biodegradable hydraulic fluids like synthetic esters, polyglycols and vegetable oils as well as petroleum-based fluids.

OPTIONAL



CM2T-MTF: the complete range of CM2T is also available with the Gates special MegaTuff™ cover which offers 300 times the abrasion resistance of the standard CM2T cover as per ISO 6945, superior ozone and weathering resistance.

IMPORTANT



Please consult Gates' Product Application Engineers for use of MegaTuff™ hose in reverse bending applications.

HYDRAULIC HOSE TO EN / SAE STANDARD

THE WORLD OF HOSE

M2T



-size	↔		⊘		⌚		🔥		📏	🏋️	📦
	DN	"	"	mm	PSI	MPa	PSI	MPa	mm	kg/100m	REF.
-20	31	1.1/4	1.67	42.3	2300	15.9	9200	63.6	210	225	20M2T
-24	38	1.1/2	2.00	50.8	2000	14.0	8000	56.0	254	263	24M2T
-32	51	2	2.53	64.3	1500	10.3	6000	41.2	318	335	32M2T

RECOMMENDED FOR	High pressure hydraulic applications. Easy to route and to install in tight areas.
TUBE	NBR (Nitrile) based.
REINFORCEMENT	Two braids of high tensile steel wire.
COVER	NBR (Nitrile) based. MSHA approved.
TEMPERATURE RANGE	-40°C to +100°C constant and +121°C intermittent. For water emulsions, etc. see Temperature Limits Table.
STANDARDS	Exceeds ISO 11237 2SC R16S. SAE 100R16 (-20). Exceeds ISO 1436 2SN R2ATS. EN 853 2SN. SAE 100R2AT.
COUPLINGS	-20: MegaCrimp® ; -24, -32: GlobalSpiral Plus.
TYPE APPROVALS	DNV and ABS.
CHARACTERISTICS/BENEFITS	75% of ISO 11237 2SC (-20) and 50% of ISO 1436 2SN R2 (-24 and -32) bend radius at rated working pressure. Superior flex impulse performance. Higher working pressure than ISO 11237 2SC R16 (-20) and ISO 1436 2SN R2 (-24 and -32). Lightweight. M2T hose is compatible with biodegradable hydraulic fluids like synthetic esters, polyglycols and vegetable oils as well as petroleum-based fluids.

HYDRAULIC HOSE TO EN / SAE STANDARD

CM2TDL-XTF

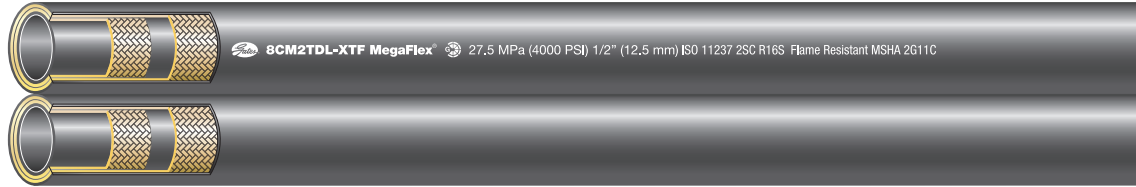

↔		⊘		⌚		🔥		⌚		⚖️	📏
-size	DN	"	"	mm	PSI	MPa	PSI	MPa	mm	kg/100m	REF.
-6	10	3/8	0.70	17.7	4800	33.0	19200	132.0	65	86	6CM2TDL-XTF
-8	12	1/2	0.82	20.8	4000	27.5	16000	110.0	90	104	8CM2TDL-XTF

RECOMMENDED FOR

High pressure and return lines such as boom arm and forklift applications.

TUBE

NBR (Nitrile) based.

REINFORCEMENT

Two braids of high tensile steel wire.

COVER

NBR (Nitrile) based. MSHA approved.

TEMPERATURE RANGE

-40°C to +100°C constant and +121°C intermittent. For water emulsions, etc. see Temperature Limits Table.

STANDARDS

Exceeds ISO 11237 2SC R16S. EN 857 2SC. SAE 100R16.

COUPLINGS

MegaCrimp®.

CHARACTERISTICS/BENEFITS

70% of EN 857 2SC bend radius at rated working pressure.

Superior flex impulse performance.

Lightweight.

CM2T - Twin hose is compatible with biodegradable hydraulic fluids like synthetic esters, polyglycols and vegetable oils as well as petroleum-based fluids.

No need to use clamps as the two lines are vulcanised together to form one single unit.

Gates special XtraTuff™ cover which offers 25 times the abrasion resistance of the standard CM2T cover as per ISO 6945.

IMPORTANT



Gates recommends minimum split length of 250 mm depending on the application. Do not expose hose reinforcement when splitting hoses.

HYDRAULIC HOSE TO EN / SAE STANDARD

THE WORLD OF HOSE

G2



-size	↔		⊘		⌚		🌪️		📏	🏋️	📦
	DN	"	"	mm	PSI	MPa	PSI	MPa	mm	kg/100m	REF.
-4	6	1/4	0.58	15.0	5800	40.0	23200	160.0	50	35	4G2
-5	8	5/16	0.64	16.3	5000	35.0	20000	140.0	55	39	5G2
-6	10	3/8	0.73	18.8	4800	33.0	19200	132.0	65	51	6G2
-8	12	1/2	0.86	21.8	4000	27.5	16000	112.0	90	61	8G2
-10	16	5/8	0.98	25.1	3625	25.0	14500	100.0	100	73	10G2
-12	19	3/4	1.14	29.0	3100	21.5	12400	86.0	120	91	12G2
-16	25	1	1.48	37.6	2400	16.5	9600	66.0	150	129	16G2
-20	31	1.1/4	1.87	47.5	1825	12.5	7300	50.0	210	225	20G2
-24	38	1.1/2	2.15	54.6	1300	9.0	5200	36.0	250	263	24G2
-32	51	2	2.65	67.3	1175	8.0	4700	32.0	315	335	32G2

RECOMMENDED FOR	High pressure hydraulic applications.
TUBE	NBR (Nitrile) based.
REINFORCEMENT	Two braids of high tensile steel wire.
COVER	NBR/PVC based. MSHA approved.
TEMPERATURE RANGE	-40°C to +100°C constant and +121°C intermittent. For water emulsions, etc. see Temperature Limits Table.
STANDARDS	Exceeds ISO 1436 2SN R2ATS. EN 853 2SN. SAE 100R2AT.
COUPLINGS	-4 to -20: MegaCrimp®; -24, -32: GlobalSpiral Plus.
TYPE APPROVALS	DNV, GL, LR, BV and ABS.
CHARACTERISTICS/BENEFITS	50% of SAE 100R2 bend radius at rated working pressure. Superior flex impulse performance: tested to 600,000 impulse cycles. G2 hose is compatible with biodegradable hydraulic fluids like synthetic esters, polyglycols and vegetable oils as well as petroleum-based fluids.

OPTIONAL

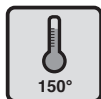

G2XH: For high-temperature applications, Gates recommends the G2XH hose range up to +150°C constant. Please refer to page 64.



G2L: for low-temperature applications, Gates recommends the G2L range down to -57°C constant. Please refer to page 66.

HYDRAULIC HOSE TO EN / SAE STANDARD

G1



-size											REF.
	DN	"	"	mm	PSI	MPa	PSI	MPa	mm	kg/100m	
-4	6	1/4	0.53	13.5	3250	22.5	13000	90.0	50	22	4G1
-5	8	5/16	0.59	15.1	3100	21.5	12400	86.0	55	26	5G1
-6	10	3/8	0.69	17.1	2600	18.0	10400	72.0	65	32	6G1
-8	12	1/2	0.82	20.3	2325	16.0	9300	64.0	90	39	8G1
-10	16	5/8	0.94	23.5	1900	13.0	7600	52.0	100	46	10G1
-12	19	3/4	1.10	27.6	1525	10.5	6100	42.0	120	59	12G1
-16	25	1	1.41	35.4	1275	9.0	5100	36.0	150	84	16G1
-20	31	1.1/4	1.71	43.4	925	6.4	3700	25.6	210	128	20G1
-24	38	1.1/2	1.96	49.8	725	5.0	2900	20.0	250	145	24G1
-32	51	2	2.52	64.0	600	4.2	2400	16.8	315	205	32G1

RECOMMENDED FOR	Medium pressure hydraulic applications.
TUBE	NBR (Nitrile) based.
REINFORCEMENT	One braid of high tensile steel wire.
COVER	NBR/PVC based. MSHA approved.
TEMPERATURE RANGE	-40°C to +100°C constant and +121°C intermittent. For water emulsions, etc. see Temperature Limits Table.
STANDARDS	Exceeds ISO 1436 1SN R1ATS. EN 853 1SN. SAE 100R1AT.
COUPLINGS	-4 to -20: MegaCrimp®; -24, -32: GlobalSpiral Plus.
TYPE APPROVALS	DNV, GL, LR, BV and ABS.
CHARACTERISTICS/BENEFITS	50% of SAE 100R1 bend radius at rated working pressure. Superior flex impulse performance: tested to 600,000 impulse cycles. G1 hose is compatible with biodegradable hydraulic fluids like synthetic esters, polyglycols and vegetable oils as well as petroleum-based fluids.

OPTIONAL

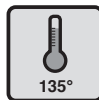

G1H: For high-temperature applications, Gates recommends the G1H hose range up to +135°C constant. Please refer to page 67.

HYDRAULIC HOSE TO EN / SAE STANDARD

THE WORLD OF HOSE

TH8

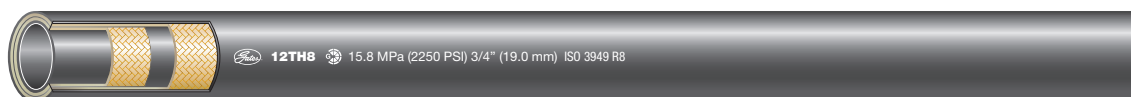

-size	↔		⊘		⌚		🌪️		📏	🏋️	📦
	DN	"	"	mm	PSI	MPa	PSI	MPa	mm	kg/100m	REF.
-4	6	1/4	0.61	15.5	5000	35.0	20000	140.0	50	18	4TH8
-6	10	3/8	0.76	19.1	4000	28.0	16000	112.0	65	31	6TH8
-8	12	1/2	0.87	22.1	3500	24.5	14000	98.0	100	34	8TH8
-12	19	3/4	1.13	28.7	2250	15.8	9000	63.2	165	38	12TH8
-16	25	1	1.45	36.8	2000	14.0	8000	56.0	250	57	16TH8

RECOMMENDED FOR

High pressure hydraulic applications, especially material handling equipment with mast and pulley systems like forklifts, aerial lifting, hydraulic boom cranes and many others.

TUBE

PA (Nylon) based.

REINFORCEMENT

Two fibre braids.

COVER

PU (Polyurethane) based. Black TH8 is perforated for use in general hydraulic and pneumatic service.

TEMPERATURE RANGE

-53°C to +93°C. For water emulsions, etc. see Temperature Limits Table.

STANDARDS

Exceeds ISO 3949 R8. EN 855 R8. SAE 100R8.

COUPLINGS

MegaCrimp®.

OPTIONAL



TH8NC: Sizes -04, -06 and -08 are also available in a non-conductive version. TH8NC has an orange polyurethane cover and is non-perforated for applications requiring electrical non-conductivity. TH8NC meets the SAE 100R8 Electrical Conductivity Test.

HYDRAULIC HOSE TO EN / SAE STANDARD

TH7

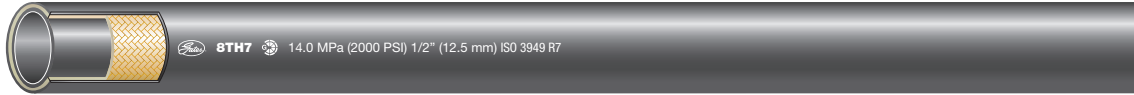

-size	↔		⊘		⌚		🌪️		🔧	🏋️	📏
	DN	"	"	mm	PSI	MPa	PSI	MPa	mm	kg/100m	REF.
-4	6	1/4	0.50	12.7	2750	19.2	11000	76.8	30	8	4TH7S
-5	8	5/16	0.56	14.7	2500	17.5	10000	70.0	45	10	5TH7S
-6	10	3/8	0.64	16.4	2250	15.8	9000	63.2	50	14	6TH7S
-8	12	1/2	0.80	20.3	2000	14.0	8000	56.0	75	21	8TH7S
-12	19	3/4	1.05	26.6	1250	8.7	5000	34.8	130	29	12TH7
-16	25	1	1.32	33.4	1000	7.0	4000	28.0	250	40	16TH7

RECOMMENDED FOR

High pressure hydraulic applications, especially material handling equipment with mast and pulley systems like forklifts, aerial lifting, hydraulic boom cranes and many others.

TUBE

PA (Nylon) based.

REINFORCEMENT

-4 to -6: spiralled synthetic fibre; -8 to -12: one fibre braid.

COVER

PU (Polyurethane) based. Black TH7 is perforated for use in general hydraulic and pneumatic service.

TEMPERATURE RANGE

-53°C to +93°C. For water emulsions, etc. see Temperature Limits Table.

STANDARDS

Exceeds ISO 3949 R7. EN 855 R7. SAE 100R7.

COUPLINGS

MegaCrimp®.

OPTIONAL



TH7NC: The complete range (-4 up to -16) is also available in a non-conductive version. TH7NC has an orange polyurethane cover and is non-perforated for applications requiring electrical non-conductivity. TH7NC meets the SAE 100R7 Electrical Conductivity Test.

HYDRAULIC HOSE TO EN / SAE STANDARD

THE WORLD OF HOSE

TH7DL

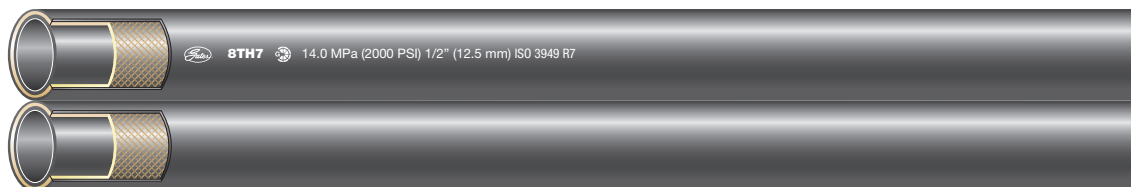

-size	↔		⊘		⌚		🔥		🔧		REF.
	DN	"	"	mm	PSI	MPa	PSI	MPa	mm	kg/100m	
-4	6	1/4	0.50	12.7	2750	19.2	11000	76.8	30	17	4TH7DL
-5	8	5/16	0.56	14.7	2500	17.5	10000	70.0	45	21	5TH7DL
-6	10	3/8	0.64	16.4	2250	15.8	9000	63.2	50	28	6TH7DL
-8	12	1/2	0.80	20.3	2000	14.0	8000	56.0	75	42	8TH7DL

RECOMMENDED FOR

High pressure hydraulic applications, especially material handling equipment with mast and pulley systems like forklifts, aerial lifting, hydraulic boom cranes and many others.

TUBE

PA (Nylon) based.

REINFORCEMENT

-4 to -6: spiralled synthetic fibre; -8 to -12: one fibre braid.

COVER

PU (Polyurethane) based. Black TH7DL is perforated for use in general hydraulic and pneumatic service.

TEMPERATURE RANGE

-53°C to +93°C. For water emulsions, etc. see Temperature Limits Table.

STANDARDS

Exceeds ISO 3949 R7. EN 855 R7. SAE 100R7.

COUPLINGS

MegaCrimp®.

OPTIONAL



TH7DLNC: Sizes -04, -06 and -08 are also available in a non-conductive version. TH7DLNC has an orange polyurethane cover and is non-perforated for applications requiring electrical non-conductivity. TH7DLNC meets the SAE 100R7 Electrical Conductivity Test.

HYDRAULIC HOSE TO EN / SAE STANDARD

G3H



↔		○			⌚		🌀		⌚		⚖️	📏
-size	DN	"	"	mm	PSI	MPa	PSI	MPa	mm	mm/Hg	kg/100m	REF.
-4	6	1/4	0.56	14.2	1250	8.8	5000	35.0	75	710	19	4G3H
-6	10	3/8	0.75	19.1	1125	7.9	4500	31.5	100	710	33	6G3H
-8	12	1/2	0.94	23.9	1000	7.0	4000	28.0	125	710	48	8G3H
-10	16	5/8	1.10	27.9	900	6.2	3600	24.8	140	710	57	10G3H
-12	19	3/4	1.25	31.8	750	5.2	3000	21.0	150	710	71	12G3H
-16	25	1	1.50	38.1	565	3.9	2260	15.8	200	510	92	16G3H
-20	31	1.1/4	1.75	44.5	375	2.6	1500	10.5	250	380	110	20G3H

RECOMMENDED FOR	High-temperature, low pressure hydraulic oil lines, anti-freeze solutions and water.
TUBE	NBR (Nitrile) based.
REINFORCEMENT	Two fibre braids.
COVER	CR (Chloroprene) based.
TEMPERATURE RANGE	-40°C to +135°C constant and +150°C intermittent. For water emulsions, etc. see Temperature Limits Table.
STANDARDS	Exceeds ISO 4079 R3. EN 854 R3. SAE 100R3.
COUPLINGS	-4 to -10: MegaCrimp®; for replacement of crimped assemblies with larger inner diameter we recommend to use ACR MegaTech®, see page 82.

HYDRAULIC HOSE TO EN / SAE STANDARD

THE WORLD OF HOSE

GTH

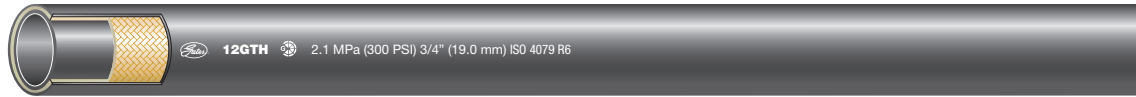

↔		○			⌚		🌸		📏		⚖️	📦
-size	DN	"	"	mm	PSI	MPa	PSI	MPa	mm	mm/Hg	kg/100m	REF.
-4	6	1/4	0.50	12.7	400	2.8	1600	11.2	65	710	13	4GTH
-5	8	5/16	0.56	14.3	400	2.8	1600	11.2	75	710	15	5GTH
-6	10	3/8	0.63	15.9	400	2.8	1600	11.2	75	710	17	6GTH
-8	12	1/2	0.78	19.8	400	2.8	1600	11.2	100	450	23	8GTH
-10	16	5/8	0.91	23.0	350	2.4	1400	9.6	125	380	28	10GTH
-12	19	3/4	1.06	26.9	300	2.1	1200	8.4	150	380	38	12GTH
-16	25	1	1.32	33.5	250	1.7	1000	6.9	165	250	47	16GTH

RECOMMENDED FOR

High-temperature, low pressure hydraulic oil lines, heavy-duty transmission oil cooler lines and glycol anti-freeze solutions.

TUBE

NBR (Nitrile) based.

REINFORCEMENT

One fibre braid.

COVER

CR (Chloroprene) based.

TEMPERATURE RANGE

-40°C to +135°C constant and +150°C intermittent. For water emulsions, etc. see Temperature Limits Table.

STANDARDS

Meets ISO 4079 R6 / EN 854 R6 / SAE 100R6 [-4 to -12].

COUPLINGS

MegaCrimp®.

HYDRAULIC HOSE TO EN / SAE STANDARD

GMV MEGAVAC®



↔		○			⌚		🔥		⌚		⚖️	📏
-size	DN	"	"	mm	PSI	MPa	PSI	MPa	mm	mm/Hg	kg/100m	REF.
-12	19	3/4	1.22	30.9	350	2.4	1400	9.6	65	635	62	12GMV
-16	25	1	1.45	36.9	300	2.1	1200	8.4	75	635	75	16GMV
-20	31	1.1/4	1.75	44.6	250	1.7	1000	6.8	100	635	92	20GMV
-24	38	1.1/2	1.95	49.53	162	1.1	648	4.4	130	635	106	24GMV
-32	51	2	2.47	62.73	112	0.8	448	3.2	150	635	170	32GMV
-40	63	2.1/2	3.02	76.7	68	0.5	272	2.0	180	635	207	40GMV
-48	76	3	3.51	89.2	62	0.4	248	1.7	230	635	243	48GMV
-56	89	3.1/2	4.01	101.9	56	0.4	224	1.5	250	635	268	56GMV
-64	102	4	4.51	114.6	56	0.4	224	1.5	300	635	305	64GMV

RECOMMENDED FOR

Petroleum and water based hydraulic fluids in suction lines or in low pressure return lines.

TUBE

NBR (Nitrile) based.

REINFORCEMENT

-12, -16, -20: fibre braid reinforced with helical spiral wire to prevent collapse;
-24 to -64: spiralled fibre reinforced with helical spiral wire to prevent collapse.

COVER

CR (Chloroprene) based. MSHA approved.

TEMPERATURE RANGE

-40°C to +135°C constant and +150°C intermittent. For water emulsions, etc. see Temperature Limits Table.

STANDARDS

SAE 100R4.

COUPLINGS

-12 to -20: MegaCrimp®; -24, -32: GlobalSpiral Plus.

CHARACTERISTICS/BENEFITS

Half the bend radius of SAE 100R4.

Flexible.

Lightweight.

HYDRAULIC HOSE

SPECIAL HIGH / LOW TEMPERATURE

THE WORLD OF HOSE

EFG6KL



↔		⊘		⌚		🔥		📏		📊	
-size	DN	"	"	mm	PSI	MPa	PSI	MPa	mm	kg/100m	REF.
-8	12	1/2	0.95	24.0	6000	42.0	24000	168.0	90	90	8EFG6KL
-10	16	5/8	1.09	27.6	6000	42.0	24000	168.0	100	115	10EFG6KL
-12	19	3/4	1.24	31.5	6000	42.0	24000	168.0	120	143	12EFG6KL
-16	25	1	1.53	38.9	6000	42.0	24000	168.0	150	192	16EFG6KL

RECOMMENDED FOR	Extremely high pressure and high impulse hydraulic applications at extremely low temperatures.
TUBE	NBR (Nitrile) based.
REINFORCEMENT	Four alternating layers of spiralled, high tensile steel wire.
COVER	CR (Chloroprene) based. MSHA approved.
TEMPERATURE RANGE	-57°C to +100°C constant and +121°C intermittent. For water emulsions, etc. see Temperature Limits Table.
STANDARDS	Exceeds ISO 3862 R15. SAE 100R15.
COUPLINGS	GlobalSpiral.
CHARACTERISTICS/BENEFITS	40% of EN 856 4SP/4SH bend radius at rated working pressure. Extremely flexible. Superior flex impulse performance: tested to 1,000,000 impulse cycles at 50% of SAE 100R15 bend radii. Meets or exceeds performance requirements of EN 856 4SP / 4SH. EFG6KL hose is compatible with biodegradable hydraulic fluids like synthetic esters, polyglycols and vegetable oils as well as petroleum-based fluids.

HYDRAULIC HOSE

SPECIAL HIGH / LOW TEMPERATURE

EFG5KL



↔		⊘		⌚		🔥		📏		📊	📦
-size	DN	"	"	mm	PSI	MPa	PSI	MPa	mm	kg/100m	REF.
-6	10	3/8	0.80	20.2	5000	35.0	20000	140.0	65	71	6EFG5KL
-8	12	1/2	0.95	24.0	5000	35.0	20000	140.0	90	89	8EFG5KL
-10	16	5/8	1.09	27.6	5000	35.0	20000	140.0	100	115	10EFG5KL
-12	19	3/4	1.24	31.4	5000	35.0	20000	140.0	120	144	12EFG5KL
-16	25	1	1.53	38.7	5000	35.0	20000	140.0	150	223	16EFG5KL
-20	31	1.1/4	1.97	50.0	5000	35.0	20000	140.0	210	399	20EFG5KL
-24	38	1.1/2	2.26	57.4	5000	35.0	20000	140.0	250	482	24EFG5KL

RECOMMENDED FOR	Extremely high pressure and high impulse hydraulic applications at extremely low temperatures.
TUBE	NBR (Nitrile) based.
REINFORCEMENT	Four (six for -20 and -24) alternating layers of spiralled, high tensile steel wire.
COVER	CR (Chloroprene) based. MSHA approved.
TEMPERATURE RANGE	-57°C to +100°C constant and +121°C intermittent. For water emulsions, etc. see Temperature Limits Table.
STANDARDS	Exceeds ISO 3862 R13. SAE 100R13.
COUPLINGS	GlobalSpiral.
CHARACTERISTICS/BENEFITS	40% of EN 856 4SP/4SH bend radius at rated working pressure. Extremely flexible. Superior flex impulse performance: tested to 1,000,000 impulse cycles at 50% of SAE 100R13 bend radii. Meets or exceeds performance requirements of EN 856 4SP. EFG5KL hose is compatible with biodegradable hydraulic fluids like synthetic esters, polyglycols and vegetable oils as well as petroleum-based fluids.

HYDRAULIC HOSE

SPECIAL HIGH / LOW TEMPERATURE

THE WORLD OF HOSE

EFG4KL



↔		⊘		⌚		🔥		📏		📊	
-size	DN	"	"	mm	PSI	MPa	PSI	MPa	mm	kg/100m	REF.
-6	10	3/8	0.81	20.6	4000	28.0	16000	112.0	65	71	6EFG4KL
-8	12	1/2	0.95	24.0	4000	28.0	16000	112.0	90	89	8EFG4KL
-12	19	3/4	1.21	30.7	4000	28.0	16000	112.0	120	128	12EFG4KL
-16	25	1	1.49	37.8	4000	28.0	16000	112.0	150	188	16EFG4KL
-20	31	1.1/4	1.85	47.0	4000	28.0	16000	112.0	210	283	20EFG4KL

RECOMMENDED FOR	Extremely high pressure and high impulse hydraulic applications at extremely low temperatures.
TUBE	NBR (Nitrile) based.
REINFORCEMENT	Four alternating layers of spiralled, high tensile steel wire.
COVER	CR (Chloroprene) based. MSHA approved.
TEMPERATURE RANGE	-57°C to +100°C constant and +121°C intermittent. For water emulsions, etc. see Temperature Limits Table.
STANDARDS	Exceeds ISO 3862 R12. SAE 100R12.
COUPLINGS	GlobalSpiral.
CHARACTERISTICS/BENEFITS	40% of EN 856 4SP bend radius at rated working pressure. Extremely flexible. Superior flex impulse performance: tested to 1,000,000 impulse cycles at 50% of SAE 100R12 bend radii. Meets or exceeds performance requirements of EN 856 4SP. EFG4KL hose is compatible with biodegradable hydraulic fluids like synthetic esters, polyglycols and vegetable oils as well as petroleum-based fluids.

HYDRAULIC HOSE

SPECIAL HIGH / LOW TEMPERATURE

M4KH



-size	↔		⊘		⌚		🔥		🔧	🏋️	📏
	DN	"	"	mm	PSI	MPa	PSI	MPa	mm	kg/100m	REF.
-4	6	1/4	0.54	13.7	4000	28.0	16000	112.0	50	33	4M4KH
-6	10	3/8	0.69	17.5	4000	28.0	16000	112.0	65	46	6M4KH
-8	12	1/2	0.82	20.8	4000	28.0	16000	112.0	90	57	8M4KH
-10	16	5/8	0.98	25.0	4000	28.0	16000	112.0	100	82	10M4KH
-12	19	3/4	1.17	29.6	4000	28.0	16000	112.0	120	109	12M4KH

RECOMMENDED FOR	High pressure hydraulic applications. Easy to route and to install in tight areas.
TUBE	NBR (Nitrile) based.
REINFORCEMENT	Two braids of high tensile steel wire.
COVER	CR (Chloroprene) based. MSHA approved.
TEMPERATURE RANGE	-40°C to +121°C. For water emulsions, etc. see Temperature Limits Table.
STANDARDS	Exceeds ISO 11237 R19. SAE 100R19.
COUPLINGS	MegaCrimp®.
CHARACTERISTICS/BENEFITS	70% of EN 857 2SC and 50% of EN 853 2SN bend radius at rated working pressure. Alternative to spiral hoses in high pressure lines where flexibility is required. Superior flex impulse performance: tested to 600,000 impulse cycles. Meets or exceeds EN 857 2SC performance requirements. Lightweight. M4KH hose is compatible with biodegradable hydraulic fluids like synthetic esters, polyglycols and vegetable oils as well as petroleum-based fluids.

OPTIONAL  M4KH-MTF: the complete range of M4KH is also available with the Gates special MegaTuff™ cover which offers 300 times the abrasion resistance of the standard M4KH cover as per ISO 6945, superior ozone and weathering resistance.

IMPORTANT  Please consult Gates' Product Application Engineers for use of MegaTuff™ hose in reverse bending applications.

HYDRAULIC HOSE

SPECIAL HIGH / LOW TEMPERATURE

THE WORLD OF HOSE

M4KL



↔		○		⌚		🔥		🔧		🏋️	📏
-size	DN	"	"	mm	PSI	MPa	PSI	MPa	mm	kg/100m	REF.
-4	6	1/4	0.55	14.0	4000	28.0	16000	112.0	50	30	4M4KL
-5	8	5/16	0.60	15.2	4000	28.0	16000	112.0	55	34	5M4KL
-6	10	3/8	0.70	17.7	4000	28.0	16000	112.0	65	43	6M4KL
-8	12	1/2	0.82	20.7	4000	28.0	16000	112.0	90	52	8M4KL
-10	16	5/8	0.99	25.0	4000	28.0	16000	112.0	100	73	10M4KL
-12	19	3/4	1.17	29.6	4000	28.0	16000	112.0	120	100	12M4KL

RECOMMENDED FOR

High pressure hydraulic applications at extremely low temperatures. Easy to route and to install in tight areas.

TUBE

NBR (Nitrile) based.

REINFORCEMENT

Two braids of high tensile wire.

COVER

NBR/PVC based. MSHA approved.

TEMPERATURE RANGE

-57°C to +100°C constant and +121°C intermittent. For water emulsions, etc. see Temperature Limits Table.

STANDARDS

Exceeds ISO 11237 R19. SAE 100R19.

COUPLINGS

MegaCrimp®.

CHARACTERISTICS/BENEFITS

70% of EN 857 2SC and 50% of EN 853 2SN bend radius at rated working pressure.

Alternative to spiral hoses in high pressure lines where flexibility is required.

Meets or exceeds EN 857 2SC and EN 853 2SN performance requirements.

Lightweight.

M4KL hose is compatible with biodegradable hydraulic fluids like synthetic esters, polyglycols and vegetable oils as well as petroleum-based fluids.

HYDRAULIC HOSE

SPECIAL HIGH / LOW TEMPERATURE

M3KH



-size	↔		⊘		⌚		🌸		📏	🏋️	📦
	DN	"	"	mm	PSI	MPa	PSI	MPa	mm	kg/100m	REF.
-4	6	1/4	0.48	12.2	3250	22.5	13000	90.0	50	19	4M3KH
-5	8	5/16	0.59	15.1	3250	22.5	13000	90.0	55	26	5M3KH
-6	10	3/8	0.63	16.0	3250	22.5	13000	90.0	65	31	6M3KH
-8	12	1/2	0.80	20.2	3250	22.5	13000	90.0	90	41	8M3KH
-10	16	5/8	0.99	25.2	3250	22.5	13000	90.0	100	73	10M3KH
-12	19	3/4	1.14	29.0	3250	22.5	13000	90.0	120	91	12M3KH
-16	25	1	1.48	37.7	3250	22.5	13000	90.0	150	155	16M3KH

- RECOMMENDED FOR** High pressure hydraulic applications. Easy to route and to install in tight areas.
- TUBE** NBR (Nitrile) based.
- REINFORCEMENT** -4 to -8: one braid of high tensile steel wire; -10 to -16: two braids of high tensile steel wire.
- COVER** CR (Chloroprene) based. MSHA approved.
- TEMPERATURE RANGE** -40°C to +121°C. For water emulsions, etc. see Temperature Limits Table.
- STANDARDS** Exceeds ISO 11237 R17. SAE 100R17.
- COUPLINGS** MegaCrimp®.
- CHARACTERISTICS/BENEFITS** 70% of EN 857 2SC and 50% of EN 853 2SN bend radius at rated working pressure.
Alternative to spiral hoses in high pressure lines where flexibility is required.
Superior flex impulse performance: tested to 600,000 impulse cycles.
Meets or exceeds EN 857 1SC/2SC performance requirements.
Lightweight.
M3KH hose is compatible with biodegradable hydraulic fluids like synthetic esters, polyglycols and vegetable oils as well as petroleum-based fluids.

OPTIONAL  M3KH-MTF (except -5): the complete range of M3KH is also available with the Gates special MegaTuff™ cover which offers 300 times the abrasion resistance of the standard M3KH cover as per ISO 6945, superior ozone and weathering resistance.

IMPORTANT  Please consult Gates' Product Application Engineers for use of MegaTuff™ hose in reverse bending applications.

HYDRAULIC HOSE

SPECIAL HIGH / LOW TEMPERATURE

THE WORLD OF HOSE

G2XH



↔		○		⌚		🔥		🔧		📊	📏
-size	DN	"	"	mm	PSI	MPa	PSI	MPa	mm	kg/100m	REF.
-4	6	1/4	0.59	14.9	6000	42.0	24000	168.0	100	42	4G2XH
-6	10	3/8	0.74	18.8	5000	35.0	20000	132.0	130	54	6G2XH
-8	12	1/2	0.86	21.8	4250	29.0	17000	116.0	180	65	8G2XH
-10	16	5/8	0.99	25.1	3625	25.0	14500	100.0	200	77	10G2XH
-12	19	3/4	1.15	29.1	3100	21.5	12400	86.0	240	94	12G2XH
-16	25	1	1.48	37.6	2500	17.5	10000	70.0	300	141	16G2XH
-20	31	1.1/4	1.86	47.2	2250	15.5	9000	62.0	420	212	20G2XH
-24	38	1.1/2	2.15	54.6	1800	12.4	6000	42.0	500	207	24G2XH
-32	51	2	2.65	67.3	1500	10.3	5200	35.9	630	293	32G2XH

RECOMMENDED FOR	High-temperature, high pressure hydraulic applications such as engine compartments, foundries,...
TUBE	CPE (Chlorinated polyethylene) based.
REINFORCEMENT	Two braids of high tensile steel wire.
COVER	CSM (Chlorosulfonated polyethylene) based. Blue. MSHA approved.
TEMPERATURE RANGE	-40°C to +150°C. For water emulsions, etc. see Temperature Limits Table.
STANDARDS	Exceeds ISO 1436 2SN R2ATS. EN 853 2SN. SAE 100R2AT.
COUPLINGS	-4 to -20: MegaCrimp®; -24 to -32: GlobalSpiral Plus.
CHARACTERISTICS/BENEFITS	Superior flex impulse performance: tested to 600,000 impulse cycles. G2XH hose is compatible with biodegradable hydraulic fluids like synthetic esters, polyglycols and vegetable oils as well as petroleum-based fluids and phosphate esters.

HYDRAULIC HOSE

SPECIAL HIGH / LOW TEMPERATURE

G2H



↔			⊘		⌚		🔥		📏		📊
-size	DN	"	"	mm	PSI	MPa	PSI	MPa	mm	kg/100m	REF.
-20	31	1.1/4	1.87	47.5	1825	12.5	7300	50.0	420	226	20G2H
-24	38	1.1/2	2.15	54.6	1300	9.0	5200	36.0	500	248	24G2H
-32	51	2	2.65	67.3	1175	8.0	4700	32.0	630	315	32G2H

RECOMMENDED FOR

High-temperature, high pressure hydraulic applications such as engine compartments, foundries,...

TUBE

NBR (Nitrile) based.

REINFORCEMENT

Two braids of high tensile steel wire.

COVER

CSM (Chlorosulfinated polyethylene) based. MSHA approved.

TEMPERATURE RANGE

-40°C to +135°C constant and +150°C intermittent. For water emulsions, etc. see Temperature Limits Table.

STANDARDS

Meets ISO 1436 2SN R2ATS / EN 853 2SN. Exceeds SAE 100R2AT.

COUPLINGS

-20: MegaCrimp®; -24 to -32: GlobalSpiral Plus.

CHARACTERISTICS/BENEFITS

Superior flex impulse performance: tested to 600,000 impulse cycles.

G2H hose is compatible with biodegradable hydraulic fluids like synthetic esters, polyglycols and vegetable oils as well as petroleum-based fluids.

OPTIONAL



G2H-MTF: the complete range of G2H is also available with the Gates special MegaTuff™ cover which offers 300 times the abrasion resistance of the standard G2H cover as per ISO 6945, superior ozone and weathering resistance.

IMPORTANT



Please consult Gates' Product Application Engineers for use of MegaTuff™ hose in reverse bending applications.

HYDRAULIC HOSE

SPECIAL HIGH / LOW TEMPERATURE

THE WORLD OF HOSE

G2L



-size	↔		⊘		⌚		🔥		📏	📊	📦
	DN	"	"	mm	PSI	MPa	PSI	MPa	mm	kg/100m	REF.
-4	6	1/4	0.58	15.0	5800	40.0	23200	160.0	100	36	4G2L
-6	10	3/8	0.73	18.8	4800	33.0	19200	132.0	130	53	6G2L
-8	12	1/2	0.86	21.8	4000	27.5	16000	112.0	180	64	8G2L
-10	16	5/8	0.98	25.1	3625	25.0	14500	100.0	200	76	10G2L
-12	19	3/4	1.14	29.0	3100	21.5	12400	86.0	240	91	12G2L
-16	25	1	1.48	37.6	2400	16.5	9600	66.0	300	136	16G2L
-20	31	1.1/4	1.87	47.5	1825	12.5	7300	50.0	420	212	20G2L
-24	38	1.1/2	2.12	53.8	1300	9.0	5200	36.0	500	223	24G2L
-32	51	2	2.62	66.5	1175	8.0	4700	32.0	630	319	32G2L

RECOMMENDED FOR	High pressure hydraulic applications at extremely low temperatures.
TUBE	NBR (Nitrile) based.
REINFORCEMENT	Two braids of high tensile steel wire.
COVER	CR (Chloroprene) based. MSHA approved.
TEMPERATURE RANGE	-57°C to +100°C. For water emulsions, etc. see Temperature Limits Table.
STANDARDS	Exceeds ISO 1436 2SN R2ATS. EN 853 2SN. SAE 100R2AT.
COUPLINGS	-4 to -20: MegaCrimp®; -24 to -32: GlobalSpiral Plus.
CHARACTERISTICS/BENEFITS	<p>Unique low temperature tube for extended service life at extremely low temperatures.</p> <p>Superior flex impulse performance: tested to 600,000 impulse cycles.</p> <p>G2L hose is compatible with biodegradable hydraulic fluids like synthetic esters, polyglycols and vegetable oils as well as petroleum-based fluids.</p>

HYDRAULIC HOSE

SPECIAL HIGH / LOW TEMPERATURE

G1H



↔		⊘		⌚		🔥		📏		📊	
-size	DN	"	"	mm	PSI	MPa	PSI	MPa	mm	kg/100m	REF.
-4	6	1/4	0.53	13.5	2750	19.2	11000	76.8	50	22	4G1H
-6	10	3/8	0.69	17.1	2250	15.7	9000	62.8	65	35	6G1H
-8	12	1/2	0.82	20.3	2000	14.0	8000	56.0	90	43	8G1H
-10	16	5/8	0.94	23.5	1500	10.5	6000	42.0	100	49	10G1H
-12	19	3/4	1.10	27.6	1250	8.7	5000	35.8	120	64	12G1H
-16	25	1	1.41	35.4	1000	7.0	4000	28.0	150	91	16G1H
-20	31	1.1/4	1.72	43.7	925	6.4	3700	25.6	210	128	20G1H
-24	38	1.1/2	1.96	49.8	725	5.0	2900	20.0	250	146	24G1H
-32	51	2	2.52	64.0	600	4.2	2400	16.8	315	207	32G1H

RECOMMENDED FOR	High-temperature, medium pressure hydraulic applications such as engine compartments, foundries,...
TUBE	NBR (Nitrile) based.
REINFORCEMENT	One braid of high tensile steel wire.
COVER	CSM (Chlorosulfonated polyethylene) based. MSHA approved.
TEMPERATURE RANGE	-40°C to +135°C constant and +150°C intermittent. For water emulsions, etc. see Temperature Limits Table.
STANDARDS	SAE 100R1.
COUPLINGS	-4 to -20: MegaCrimp®; -24 to -32: GlobalSpiral Plus.
CHARACTERISTICS/BENEFITS	50% of SAE 100R1 bend radius at rated working pressure. Superior flex impulse performance: tested to 600,000 impulse cycles.

THE WORLD OF HOSE
INTEGRATED FLUID POWER SOLUTIONS



ENGINE HOSE



ENGINE HOSE SCR

THE WORLD OF HOSE

SELECTIVE CATALYTIC REDUCTION (SCR) / DIESEL EMISSION FLUID (DEF) HEATED LINES

Selective Catalytic Reduction is an aftertreatment technology based on a chemical reaction to convert Nitrogen Oxides (NOx) into water and harmless nitrogen.

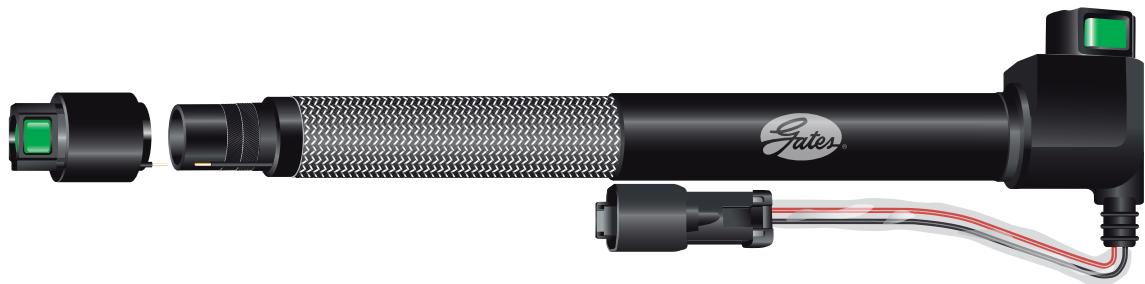
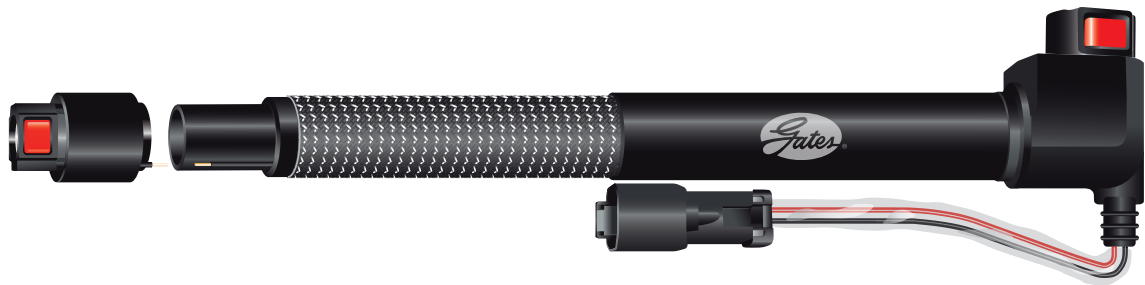

SCR as part of Gates Emission Control Solutions:

- > A firm commitment to reduce air pollution and fuel consumption.
- > A dedication to help our customers to meet present and future emission standards.
- > A continued search for new and greener technologies.

ENGINE HOSE SCR

RECOMMENDED FOR	Transfer of Diesel Emission Fluids or urea solutions such as AdBlue® used in exhaust treatment of diesel engines equipped with Selective Catalytic Reduction (SCR) Technology.
CONSTRUCTION	PA (nylon) or p-EPDM rubber tube. Carbon fibre heat sleeve. Heated quick connect couplings. Dense closed cell EPDM insulation or thermoplastic convolute. Thermoplastic overmoulded ends.
TEMPERATURE RANGE	-40°C to +125°C.
STANDARDS	SAE J2044 quick connect couplings.
CHARACTERISTICS/BENEFITS	Electrical connections per customer specification. Patented technology. 12V or 24V power source. Carbon fibre sleeve provides fast, uniform heating across the entire assembly. Woven design provides redundancy in case of damage. The carbon fibre can be varied allowing for design flexibility in terms of length and heating capacity to meet end user needs. Lengths from 170 to 5000 mm have been produced. The overmoulded ends seal electronics providing excellent corrosion protection for weatherproof design.
OPTIONAL	The SCR heated lines may be fitted with a special heat sleeve to provide heat protection in demanding applications. Gates also offers solutions for urea transfer hoses (long lengths) and urea tank fill / vent hoses (formed or straight short lengths).

IMPORTANT



Please consult Gates' Product Application Engineers on minimum assembly length questions to avoid overheating and melting of the SCR assembly.

ENGINE HOSE COOLANT

THE WORLD OF HOSE

BLUE STRIPE™



-size	↔		⊘		⌚		🌸		👤	🏋️	REF.
	DN	"	"	mm	PSI	MPa	PSI	MPa	mm	kg/100m	
-6	10	3/8	0.68	17.3	62	0.4	250	1.7	130	20	BLUE STRIPE 3/8"
-8	12	1/2	0.82	20.8	75	0.5	300	2.1	155	26	BLUE STRIPE 1/2"
-10	16	5/8	0.94	23.9	62	0.4	250	1.7	180	30	BLUE STRIPE 5/8"
-12	19	3/4	1.06	26.9	50	0.3	200	1.4	195	35	BLUE STRIPE 3/4"
-14	22	7/8	1.30	33.0	75	0.5	300	2.1	265	62	BLUE STRIPE 7/8"
-16	25	1	1.34	34.0	44	0.3	175	1.2	230	49	BLUE STRIPE 1"
-18	28	1.1/8	1.55	39.4	125	0.9	500	3.4	315	76	BLUE STRIPE 1.1/8"
-20	31	1.1/4	1.67	42.4	100	0.7	400	2.8	340	81	BLUE STRIPE 1.1/4"
-24	38	1.1/2	1.92	48.8	100	0.7	400	2.8	390	96	BLUE STRIPE 1.1/2"
-28	44	1.3/4	2.17	55.1	75	0.5	300	2.1	445	109	BLUE STRIPE 1.3/4"
-32	51	2	2.42	61.5	62	0.4	250	1.7	495	123	BLUE STRIPE 2"
-36	57	2.1/4	2.67	67.8	62	0.4	250	1.7	545	137	BLUE STRIPE 2.1/4"

RECOMMENDED FOR High-temperature coolant, water and air applications. Suitable for OAT (organic additive technology) engine fluids.

TUBE EPDM.

REINFORCEMENT -4 to -12 and -16: 4230SB - aramid spiral; -14 and -18 to -36: 4175SC - nylon cord.

COVER EPDM based.

TEMPERATURE RANGE -40°C to +150°C.

STANDARDS 4230SB - normal duty heater hose to SAE 20R3 EC Class D-1.
4175SC - heavy duty radiator hose to SAE 20R1 EC Class D-1, standard wall

CHARACTERISTICS/BENEFITS Premium engine hose.
Compounded to resist electro-chemical degradation, the leading cause of hose failure.
Wrapped cover on size 7/8" and as of size 1.1/8".

NOTE Also available as customer-made curved hose to SAE 20R4 EC D-1 to fit specific applications and meeting customer specifications. Curved hose recommended for upper, lower, by-pass, heater and other coolant applications. Can be installed without buckling, bending out of shape or straining at the connections.
Can be used with PowerGrip® Shrink Band Clamps, made from a heat-sensitive thermoplastic with a memory to prevent over- or under-tightening. Retains dynamic tension and never needs retightening. Eliminates the risk for antifreeze leaks and ground water contamination. Can be installed with an ordinary heat gun.

IMPORTANT



Do not use for fuel or oil transfer applications.

ENGINE HOSE COOLANT

4230S

RECOMMENDED FOR

Engine coolant hose such as cab heater or oil cooler.

Also suitable for air, water, or oil.

CONSTRUCTION

NBR tube, synthetic fiber reinforcement, CR cover.

Straight hose specification, available in bulk or cut lengths.

TEMPERATURE RANGE

-40°C to +100°C.

STANDARDS

Meets SAE 20R3 Class B tube, Class C cover.

INTERNAL DIAMETER

Available in 3/8", 1/2", 5/8", 3/4", and 1" standard IDs.

CHARACTERISTICS/BENEFITS

Oil resistant.

Small diameters (heater hose) up to 1" ID.



4256LS/4256VT

RECOMMENDED FOR

Engine coolant hose such as cab heater or oil cooler.

Also suitable for air or water.

CONSTRUCTION

p-EPDM tube, aramid knit reinforcement, p-EPDM cover.

Curved hose specification, customised design.

TEMPERATURE RANGE

-40°C to +150°C.

STANDARDS

Meets SAE 20R3 EC Class D3 (from size 19/32" to 1") or SAE 20R4 EC Class D3 (from size 1.06" to 2.1/2").

INTERNAL DIAMETER

Available in 19/32" to 2.1/2" standard IDs.

CHARACTERISTICS/BENEFITS

High-temperature resistant.

Material used is p-EPDM.

Electrochemically resistant (ECR).

Small diameters (heater hose) up to 1" ID.

Compatible with DEF.

IMPORTANT

Do not use for fuel or oil transfer applications.



4280MH

RECOMMENDED FOR

Engine coolant hose such as cab heater or oil cooler.

Also suitable for air or water.

CONSTRUCTION

EPDM tube, synthetic knit reinforcement, EPDM cover.

Curved hose specification, customised design.

TEMPERATURE RANGE

-40°C to +125°C.

STANDARDS

Meets SAE 20R3 EC Class D1 (from size 1/4" to 7/8") or SAE 20R4 EC Class 1 (from size 0.74" to 4").

INTERNAL DIAMETER

Available in 1/4" to 4" standard IDs.

CHARACTERISTICS/BENEFITS

Price-by-performance.

Electrochemically resistant (ECR).

Small diameters (heater hose) up to 1" ID.

IMPORTANT

Do not use for fuel or oil transfer applications.



ENGINE HOSE FUEL

THE WORLD OF HOSE

4219BG BARRICADE® GREENSHIELD®

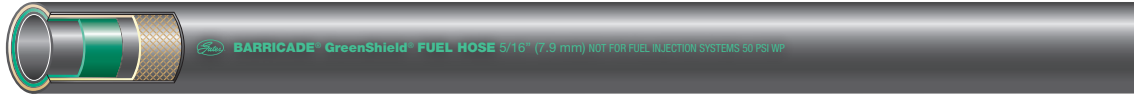

-size	↔		⊘		⌚		🔥		🔄		⊘	🏋️	📏
	DN	"	"	mm	PSI	MPa	PSI	MPa	mm	mm/Hg	kg/100m	REF.	
-3	5	3/16	0.41	10.4	50	0.3	250	1.7	55	610	7	4219BG 3/16"	
-4	6	1/4	0.50	12.7	50	0.3	250	1.7	65	610	13	4219BG 1/4"	
-5	8	5/16	0.56	14.3	50	0.3	250	1.7	75	610	15	4219BG 5/16"	
-6	10	3/8	0.62	15.9	50	0.3	250	1.7	85	610	18	4219BG 3/8"	
-8	12	1/2	0.78	19.8	35	0.2	175	1.2	120	250	24	4219BG 1/2"	

RECOMMENDED FOR Recommended for carbureted engines in cars, light trucks, off-road vehicles and small engines on which a barrier fuel hose is required.

TUBE NBR (nitrile) based.

BARRIER Thermoplastic liner.

REINFORCEMENT Polyester fibre.

COVER NBR / PVC based.

TEMPERATURE RANGE -40 to +100°C for bio-diesel use (up to B100) and up to +125°C for non-bio-diesel use.

STANDARDS CARB small engine off-road (CARB certificate Q09-019A) - 15g/m²/day.
EPA Non-Road Fuel Lines (EPA Verify Family Name: GTSPLINEBG1) - 15g/m²/day.
Exceeds SAE J30R14 T1 specification.

CHARACTERISTICS/BENEFITS Permeation rate less than 15g/m²/day at +40°C.
For use with gasoline, gasoline / ethanol blends (E10, E15, E85), 100% methanol only (methanol blends are not recommended), diesel, diesel / bio-diesel blends, 100% bio-diesel.

NOTE Most fuel constructions are considered to not be electrically conductive unless specifically marked as such.

IMPORTANT



Do not submerge in fuel.

Do not use on pressure lines on fuel injection systems or cooling system applications.

Use Barricade® GreenShield® 4219BF hose for multi-port injection systems.

ENGINE HOSE FUEL

4219BF BARRICADE® GREENSHIELD® FUEL INJECTION



-size	↔		⊘		⌚		🔥		🔧	⊘	📊	📏
	DN	"	"	mm	PSI	MPa	PSI	MPa	mm	mm/Hg	kg/100m	REF.
-3	5	3/16	0.41	10.4	225	1.5	1125	7.8	55	610	7	4219BF 3/16"
-4	6	1/4	0.50	12.7	225	1.5	1125	7.8	65	610	13	4219BF 1/4"
-5	8	5/16	0.56	14.3	225	1.5	1125	7.8	75	610	15	4219BF 5/16"
-6	10	3/8	0.62	15.9	225	1.5	1125	7.8	85	610	18	4219BF 3/8"
-8	12	1/2	0.78	19.8	225	1.5	1125	7.8	140	250	24	4219BF 1/2"

RECOMMENDED FOR

Any fuel injected engine application (1985 and newer) in cars, light trucks, off-road vehicles and small engines on which a barrier fuel hose is required.

TUBE

HNBR based.

BARRIER

Thermoplastic liner.

REINFORCEMENT

Aramid fibre.

COVER

CPE.

TEMPERATURE RANGE

-40°C to +135°C continuous service for bio-diesel use and up to +150°C intermittent service for non-bio-diesel use.

STANDARDS

CARB small engine off-road (CARB certificate Q09-019A) - 15g/m²/day.

EPA Non-Road Fuel Lines (EPA Verify Family Name: GTSPLINEBF1) - 15g/m²/day.

Exceeds SAE J30 R14 T2 (except kink) with SAE J30 R12 burst.

CHARACTERISTICS/BENEFITS

Permeation rate less than 15g/m²/day at +40°C.

For use with gasoline, gasoline / ethanol blends (E10, E15, E85), 100% methanol only (methanol blends are not recommended), diesel, diesel / bio-diesel blends, 100% bio-diesel.

NOTE

Most fuel constructions are considered to not be electrically conductive unless specifically marked as such.

IMPORTANT



Do not submerge in fuel.

ENGINE HOSE FUEL

THE WORLD OF HOSE

4219G



↔		⊘			⌚		🌿		↻		⊘	⚖	📏
-size	DN	"	"	mm	PSI	MPa	PSI	MPa	mm	mm/Hg	kg/100m	REF.	
-3	5	3/16	0.41	10.4	50	0.3	250	1.7	80	610	10	4219G 3/16"	
-4	6	1/4	0.50	12.7	50	0.3	250	1.7	80	610	13	4219G 1/4"	
-5	8	5/16	0.56	14.2	50	0.3	250	1.7	80	610	15	4219G 5/16"	
-6	10	3/8	0.62	15.8	50	0.3	250	1.7	105	610	18	4219G 3/8"	
-8	12	1/2	0.78	19.8	35	0.2	175	1.2	130	250	24	4219G 1/2"	
-10	16	5/8	0.94	23.9	35	0.2	175	1.2	155	250	34	4219G 5/8"	
-12	19	3/4	1.13	28.6	35	0.2	175	1.2	180	250	48	4219G 3/4"	

RECOMMENDED FOR

Low pressure and return lines on fuel systems. Specially designed for fuel circuits (leaded and unleaded petrol, diesel) in passenger cars and industrial vehicles. It can also be used in evaporative emission control systems and as a vent line.

TUBE

NBR (Nitrile) based.

REINFORCEMENT

Synthetic high tensile textile.

COVER

NBR / PVC based.

TEMPERATURE RANGE

-40°C to +125°C.

STANDARDS

Exceeds the requirements of SAE 30R6 and SAE 30R7 specifications for fuel line hoses.

CHARACTERISTICS/BENEFITS

Also used for crankcase ventilation.

NOTE

Most fuel constructions are considered to not be electrically conductive unless specifically marked as such.

IMPORTANT



Not recommended for fuel injection systems.

Do not submerge in fuel.

ENGINE HOSE FUEL

3284A (RLA)

RECOMMENDED FOR

Fuel line from tank to engine.
Also suitable for low pressure hydraulic oil, engine oil, or air.



CONSTRUCTION

NBR tube, synthetic fiber reinforcement, NBR/PVC cover.
Straight hose specification, available in bulk or cut lengths.

TEMPERATURE RANGE

-40°C to +100°C.

STANDARDS

Meets SAE 30R2 Type 1 or Type 2 except OD and tolerance.
Burst, vacuum, and bend radius exceed SAE 30R2.

INTERNAL DIAMETER

Available in 3/16", 1/4", 5/16", 3/8", 0.510", 5/8", 3/4", and 1".

CHARACTERISTICS/BENEFITS

Higher pressure.

IMPORTANT

Do not use for in-tank, gaseous fuels, or biodiesel applications.

42780B

RECOMMENDED FOR

Engine oil and hydraulic suction applications.



CONSTRUCTION

NBR tube, aramid knit reinforcement, NBR/PVC cover.
Curved hose specification, customised design.

TEMPERATURE RANGE

-40°C to +125°C.

STANDARDS

Meets SAE 30R2 Type 1 except burst on the 1/2" and 1" sizes, and thickness.

INTERNAL DIAMETER

Available in 1/2" to 1.1/2" standard IDs.

CHARACTERISTICS/BENEFITS

Higher pressure.

IMPORTANT

Do not use for fuel injection or air applications.

4278CN

RECOMMENDED FOR

Engine oil, fuel filler, and hydraulic suction.
Also suitable for tank vent and crank case vent.



CONSTRUCTION

NBR tube, synthetic knit reinforcement, NBR/PVC cover.
Curved hose specification, customised design.

TEMPERATURE RANGE

-40°C to +125°C.

STANDARDS

Meets SAE 30R7 except the oxidised gasoline test, or SAE 30R6.

INTERNAL DIAMETER

Available in 3/16" to 3.5/8" standard IDs.

CHARACTERISTICS/BENEFITS

Price-by-performance.

IMPORTANT

Do not use for fuel injection or air intake applications.

ENGINE HOSE AIR INTAKE

THE WORLD OF HOSE

4171H



-size	↔		○		⌚		🌀		🔧		⚖️	REF.
	DN	"	"	mm	PSI	MPa	PSI	MPa	mm	mm/Hg	kg/100m	
-14	22	7/8	1.09	27.8	200	1.4	800	5.5	220	*	30	HIGH-TEMP AIR INTAKE 7/8"
-16	25	1	1.22	31.0	200	1.4	800	5.5	245	*	33	HIGH-TEMP AIR INTAKE 1"
-20	31	1.1/4	1.47	37.4	200	1.4	800	5.5	295	*	40	HIGH-TEMP AIR INTAKE 1.1/4"
-22	35	1.3/8	1.59	40.5	200	1.4	800	5.5	320	*	43	HIGH-TEMP AIR INTAKE 1.3/8"
-24	38	1.1/2	1.72	43.7	200	1.4	800	5.5	345	*	46	HIGH-TEMP AIR INTAKE 1.1/2"
-32	51	2	2.22	56.4	160	1.1	640	4.4	450	*	61	HIGH-TEMP AIR INTAKE 2"
-36	57	2.1/4	2.47	62.8	160	1.1	640	4.4	500	*	67	HIGH-TEMP AIR INTAKE 2.1/4"
-38	60	2.3/8	2.59	65.9	140	1.0	560	3.9	525	*	70	HIGH-TEMP AIR INTAKE 2.3/8"
-40	63	2.1/2	2.72	69.1	134	0.9	534	3.7	550	*	74	HIGH-TEMP AIR INTAKE 2.1/2"
-44	70	2.3/4	2.97	75.5	120	0.8	480	3.3	600	*	88	HIGH-TEMP AIR INTAKE 2.3/4"
-48	76	3	3.22	81.8	113	0.8	452	3.1	650	*	95	HIGH-TEMP AIR INTAKE 3"
-52	83	3.1/4	3.47	88.2	105	0.7	418	2.9	705	*	98	HIGH-TEMP AIR INTAKE 3.1/4"
-54	86	3.3/8	3.60	91.3	100	0.7	400	2.8	730	*	126	HIGH-TEMP AIR INTAKE 3.3/8"
-56	89	3.1/2	3.77	95.8	120	0.8	480	3.3	765	*	135	HIGH-TEMP AIR INTAKE 3.1/2"
-60	95	3.3/4	4.02	102.1	120	0.8	480	3.3	815	*	144	HIGH-TEMP AIR INTAKE 3.3/4"
-64	102	4	4.27	108.5	113	0.8	452	3.1	865	*	152	HIGH-TEMP AIR INTAKE 4"
-72	114	4.1/2	4.77	121.2	100	0.7	400	2.8	965	*	161	HIGH-TEMP AIR INTAKE 4.1/2"
-80	127	5	5.27	133.9	90	0.6	360	2.5	1070	*	177	HIGH-TEMP AIR INTAKE 5"

RECOMMENDED FOR	High-temperature turbo hose or connector.
TUBE	Orange silicone.
REINFORCEMENT	High-temperature fabric.
COVER	Orange silicone – wrapped appearance.
TEMPERATURE RANGE	-40°C to +288°C continuous service.

* No specification requirement

ENGINE HOSE AIR INTAKE

CHARGE AIR COOLER – COLD SIDE: 4177W (GREEN STRIPE®)

RECOMMENDED FOR	Vibration dampening connector on the air filter. Also suitable for coolant or cold-side charge air connections.
CONSTRUCTION	NBR tube, synthetic fabric reinforcement plies, CR cover with wrapped appearance. Hump hose specification, fixed lengths.
TEMPERATURE RANGE	-40°C to +100°C.
STANDARDS	Exceeds SAE 20R1 Class B tube, Class C cover.
INTERNAL DIAMETER	Available in 1.1/4" to 6" standard IDs.
CHARACTERISTICS/BENEFITS	Oil resistant.
IMPORTANT	Do not use for conveying fuel or oil. There is no vacuum rating specification.

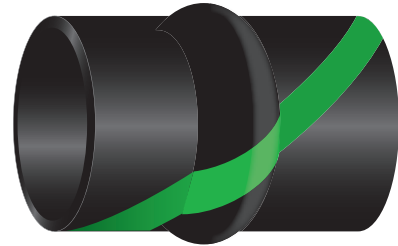

AIR INTAKE HOSE: 4289N

RECOMMENDED FOR	Engine air intake with internal oil mist, exhaust fumes, or crank case fumes, or external oily environment. Also suitable for water suction.
CONSTRUCTION	CR tube with no reinforcement. Curved hose specification, customised design.
TEMPERATURE RANGE	-40°C to +100°C.
STANDARDS	Meets SAE J200 M3BC 707 E014 E034 F17 Z1 (8.28MPa Tb), or SAE J200 M3BC 707 A14 C12 E014 E034 F17.
INTERNAL DIAMETER	Available in 5/8" to 5" standard IDs.
CHARACTERISTICS/BENEFITS	All rubber. Oil resistant.
IMPORTANT	Do not use for conveying fuel.



AIR INTAKE HOSE: 4289E

RECOMMENDED FOR	Engine air intake or air ducting. Also suitable for water suction.
CONSTRUCTION	EPDM tube with no reinforcement. Curved hose specification, customised design.
TEMPERATURE RANGE	-40°C to +135°C continuous with peaks of +150°C.
STANDARDS	Meets SAE J200 M3CA 707 A25 B35 C32 F17 Z1 (Duro 60-75), or SAE J200 M3CA 710 A25 B35 C32 EA14 F17 G21 Z1 (EPDM) Z2 (Duro 60-75).
INTERNAL DIAMETER	Available in 7/32" to 4.21" standard IDs.
CHARACTERISTICS/BENEFITS	All rubber.
IMPORTANT	Do not use for conveying fuel or oil.



ENGINE HOSE HOT OIL LINES

THE WORLD OF HOSE

C5CXH

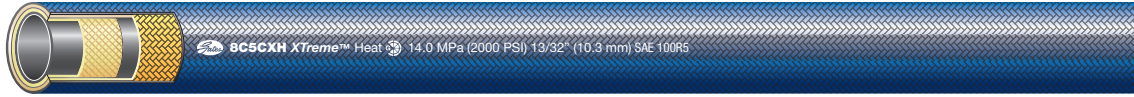

-size	↔		⊘		⌚		🌸		🔧	🏋️	📏
	DN	"	"	mm	PSI	MPa	PSI	MPa	mm	kg/100m	REF.
-5	6.3	1/4	0.58	14.7	3000	20.7	12000	82.7	85	28	5C5CXH
-6	8.0	5/16	0.68	17.3	2250	15.5	9000	62.1	100	33	6C5CXH
-8	11.0	13/32	0.77	19.6	2000	13.8	8000	55.2	115	37	8C5CXH
-10	12.5	1/2	0.92	23.4	1750	12.1	7000	48.3	140	57	10C5CXH
-12	16.0	5/8	1.08	27.4	1500	10.3	6000	41.4	165	66	12C5CXH
-16	22.2	7/8	1.23	31.2	800	5.5	3200	22.1	188	71	16C5CXH
-20	28.6	1.1/8	1.50	38.1	625	4.3	2500	17.2	229	77	20C5CXH

RECOMMENDED FOR

High-temperature lube oil lines for on-highway truck and bus, off-road construction and agricultural vehicles. Turbo charger oil supply. Air brake applications. Diesel fuel applications.

TUBE

CPE (Chlorinated polyethylene) based.

REINFORCEMENT

Braided high tensile wire and textiles.

COVER

Oil and mildew resistant polyester/textile braid. Blue.

TEMPERATURE RANGE

-40°C to +150°C for hot oil applications.

STANDARDS

Meets the requirements of SAE 100R5 for hydraulic applications, SAE 1405 hot oil circulation. DOT FMVSS-106-74 type All and SAE J1402 type All for air brake applications (-4 to -12).

COUPLINGS

-5, -6, -8, -16 and -20 : MegaCrimp® ; -10, -12 : GlobalSpiral.

CHARACTERISTICS/BENEFITS

Compatible with both petroleum and phosphate ester fluids.

Acceptable for use with oil and air for maximum application flexibility.

Has passed the tube fuel resistance requirements of SAE 30R2.

↔	Hose ID specifications (min-max) in mm		📏	Couplings for C5CXH hose sizes
	ISO 11237 2SC R16S	100 R5	REF.	
-5	7.7 – 8.5	6.4 – 7.2	5C5CXH	4G
-6	9.3 – 10.1	7.9 – 8.7	6C5CXH	5G
-8	12.3 – 13.5	10.3 – 11.1	8C5CXH	6G
-10	15.5 – 16.7	12.7 – 13.7	10C5CXH	8GS + 8GB1F-PS
-12	18.6 – 19.8	15.9 – 17.0	12C5CXH	10GS + 10GS1F-4
-16	25.0 – 26.4	22.2 – 23.3	16C5CXH	12G
-20	31.4 – 33.0	28.6 – 29.8	20C5CXH	16G

ENGINE HOSE HOT OIL LINES

MEGATECH®



-size	DN	"	"	mm	PSI	MPa	PSI	MPa	mm	mm/Hg	kg/100m	REF.
-4	6	1/4	0.52	13.2	1000	7.0	4000	28.0	50	760	18	4MEGATECH1000
-6	10	3/8	0.66	16.8	1000	7.0	4000	28.0	65	760	28	6MEGATECH1000
-8	12	1/2	0.80	20.3	1000	7.0	4000	28.0	90	760	36	8MEGATECH1000
-10	16	5/8	0.93	23.6	1000	7.0	4000	28.0	100	760	45	10MEGATECH1000
-12	19	3/4	1.15	29.2	1000	7.0	4000	28.0	120	760	60	12MEGATECH1000
-16	25	1	1.37	34.8	1000	7.0	4000	28.0	150	760	71	16MEGATECH1000
-20	31	1.1/4	1.64	41.7	1000	7.0	4000	28.0	210	760	124	20MEGATECH1000
-24	38	1.1/2	1.95	49.5	500	3.5	2000	14.0	380	760	149	24MEGATECH500
-32	51	2	2.48	63.0	500	3.5	2000	14.0	460	760	205	32MEGATECH500
-40	63	2.1/2	2.97	75.4	500	3.5	2000	14.0	560	760	219	40MEGATECH500
-48	76	3	3.50	88.9	500	3.5	2000	14.0	610	760	274	48MEGATECH500

RECOMMENDED FOR

Pressurised hot oil return lines and air compressor lines, power steering, tilt cab cylinders, engine and transmission coolant and filtration lines.

TUBE

CPE (Chlorinated polyethylene) based.

REINFORCEMENT

One braid of high tensile steel wire.

COVER

Oil resistant textile braid, impregnated with synthetic rubber.

TEMPERATURE RANGE

-40°C to +150°C. Air: -40°C to +121°C. Phosphate ester fluids: -40°C to +100°C. For water emulsions, etc. see Temperature Limits Table.

STANDARDS

Meets the requirements of SAE J1405 performance specifications for use in high-temperature transmission oil systems and high-temperature lubrication oil systems using petroleum based oils.

-4 to -10: meets SAE J1402.

COUPLINGS

-4 to -20: MegaCrimp®; -24, -32: GlobalSpiral Plus.

CHARACTERISTICS/BENEFITS

Very good resistance to weathering and ozone.

MegaTech® is compatible with a variety of fluids such as hydraulic oil, phosphate esters, diesters.

IMPORTANT



Not recommended for gasoline or diesel fuel applications.

ENGINE HOSE OTHER

THE WORLD OF HOSE

WINDSHIELD WIPER/ VACUUM HOSE: 4040A

RECOMMENDED FOR

Windshield washer lines and engine vacuum lines.

Also suitable for coolant overflow or vent or pressure sensor tubing.

CONSTRUCTION

EPDM tube with no reinforcement.

Straight hose specification, available in bulk or cut lengths.

TEMPERATURE RANGE

-40°C to +125°C.

STANDARDS

Meets SAE J1037, SAE 942, SAE J200 M4CA710 A25 B35 C32 EA14 F19.

INTERNAL DIAMETER

Available in 7/64", 5/32", 7/32", 1/4", 5/16", and 3/8" standard IDs.

CHARACTERISTICS/BENEFITS

Tubing.

IMPORTANT

Do not use for conveying fuel or oil.



AIR BRAKE HOSE: TR500

RECOMMENDED FOR

Air brake hose, high-temperature pressurised oil return lines and rotary oil/air compressor lines, engine and transmission coolant lines and lube oil lines.

CONSTRUCTION

NBR based tube, steel wire reinforcement, synthetic rubber impregnated textile braided cover.

Straight hose specification, available in bulk or cut lengths.

TEMPERATURE RANGE

-40°C to +121°C.

STANDARDS

Meets or exceeds DOT FMVSS 106-74, SAE J1402 for 1/4", 3/8", 1/2", and 5/8".

INTERNAL DIAMETER

Available in 1/4", 3/8", 1/2", 5/8", 3/4", and 1" standard IDs.

CHARACTERISTICS/BENEFITS

High-temperature resistant.

Oil and mildew resistant cover.

Validated with MegaCrimp®.

IMPORTANT

Do not use for gasoline or diesel fuel applications.



REFRIGERANT HOSE: POLARSEAL® II

RECOMMENDED FOR

AC systems for light duty (truck & bus), and other heavy equipment.

Liquid and gaseous R134a and R12 refrigerants in automotive AC and industrial systems.

CONSTRUCTION

Synthetic elastomeric rubber tube, fabric braid reinforcement, synthetic elastomeric cover, nylon liner barrier.

Straight hose specification, available in bulk or cut lengths.

TEMPERATURE RANGE

-30°C to +125°C.

STANDARDS

Meets SAE J2064 Type C, Class 1.

INTERNAL DIAMETER

Available in 5/16", 13/32", 1/2", 5/8", and 7/8" standard IDs.

CHARACTERISTICS/BENEFITS

Designed to minimise permeation of R134a refrigerant.

Heat, moisture and ozone resistant cover.



THE WORLD OF HOSE
INTEGRATED FLUID POWER SOLUTIONS



INDUSTRIAL HOSE



EXPLANATION OF THE SYMBOLS USED IN THIS DOCUMENT

THE WORLD OF HOSE

APPLICATION ICONS



Agriculture



Granulates, Powders



Air & multi-purpose



Milk



Air Breathing



Nitrogen



Beer, Wine



Oil



Blower hose



Plaster, Concrete



Cement powder, Sand



Pressure wash & wash down



Chemicals



Radiator



Cold Water



Vapour



Food



Water, Sea Water, Waste
Water, Mud, Slurry

HOMOLOGATION ICONS



FDA (US Food and Drug Administration) is an agency within the Department of Health and Human Services and consists of centres and offices. The FDA is responsible for protecting the public health by assuring the safety, efficacy, and security of human and veterinary drugs, biological products, medical devices, our nation's food supply, cosmetics, and products that emit radiation.



The United States Pharmacopeia (USP) is a non-governmental, official public standards-setting authority for prescription and over-the-counter medicines and other healthcare products manufactured or sold in the United States. USP also sets widely recognised standards for food ingredients and dietary supplements. USP sets standards for the quality, purity, strength, and consistency of these products – critical to the public health.



A hose which is capable of discharge is a hose with a resistance of more than $10^3 \Omega/m$ and less than $10^6 \Omega/m$ and is indicated with an Ω icon. An object or device is capable of discharge if its surface resistance is between $10^4 \Omega$ and $10^9 \Omega$ measured at +23°C and 50% relative humidity. The characteristic of being able to discharge is also referred to as being "anti-static".



Animal Derived Ingredients (ADI) can cause the disease BSE and should therefore be avoided in products that may come into contact with products that are intended for human consumption. Hose liner material ingredients and process aids can contain ADI. GATES has therefore checked the compound portfolio and can now offer a broad selection of ADI free food and beverage hoses.

INDUSTRIAL HOSE CLEANING

THE WORLD OF HOSE

WATER BLAST



-size	mm	"	mm	MPa	MPa	mm	kg/100m	REF.
-6	10	3/8	21.2	100.0	250.0	230	88	6WB-XTFxLL
-8	13	1/2	24.6	100.0	250.0	230	141	8WB-XTFxLL
-12	19	3/4	34.5	100.0	250.0	230	228	12WB-XTFxLL

RECOMMENDED FOR

Ultra high pressure cold water cutting devices, blasting applications and cleaning equipment including high pressure stream of sea water to remove marine growth on off-shore oil rigs.

TUBE

NBR (Nitrile) based.

REINFORCEMENT

Four (six for -12) alternating layers of spiralled, high tensile wire.

COVER

XtraTuff™. MSHA approved.

TEMPERATURE RANGE

-20°C to +70°C.

STANDARDS

Gates proprietary.

COUPLINGS

WTB.

CHARACTERISTICS/BENEFITS

Outstanding resistance to weather, oil and abrasion.
Very flexible spiral wire design.

NOTE

Gates Water Blast hose is not to be used for impulse applications.

IMPORTANT



In line with international standards (EN 1829-2), each hose assembly should be subjected to a proof pressure hold test. The test pressure shall be 1.5 times the maximum allowable working pressure, the safety factor for burst pressure shall be at least 2.5 times the maximum allowable working pressure.

INDUSTRIAL HOSE CLEANING

JETCLEAN™ 2JC

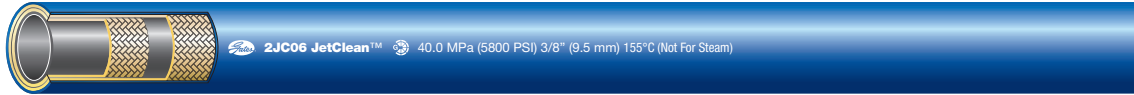

-size	mm	"	mm	MPa	MPa	mm	kg/100m	REF.
-5	8	5/16	16.3	40.0	140.0	55	38	2JC05
-6	10	3/8	18.8	40.0	132.0	65	49	2JC06
-5	8	5/16	16.3	40.0	140.0	55	38	2JC05B
-6	10	3/8	18.8	40.0	132.0	65	49	2JC06B
-8	13	1/2	21.8	40.0	110.0	90	63	2JC08B
-6	10	3/8	18.8	40.0	132.0	65	49	2JC06G

RECOMMENDED FOR

Use on hot and cold water high pressure cleaning equipment where heavy-duty service is required. Suited for agricultural, sports, valet and maintenance service applications.

TUBE

NBR (Nitrile) based.

REINFORCEMENT

Two wire braid.

COVER

NBR/PVC based. Available in black, blue (B) and grey (G).

TEMPERATURE RANGE

-40°C to +155°C.

STANDARDS

Gates proprietary.

COUPLINGS

MegaCrimp®.

CHARACTERISTICS/BENEFITS

Grey and blue JetClean™ are suitable for use in hospitals, swimming pools and other applications where hygiene is of the utmost importance.

Premium temperature resistance up to +155°C.

IMPORTANT



Not recommended for steam service.

INDUSTRIAL HOSE CLEANING

THE WORLD OF HOSE

JETCLEAN™ 1JC

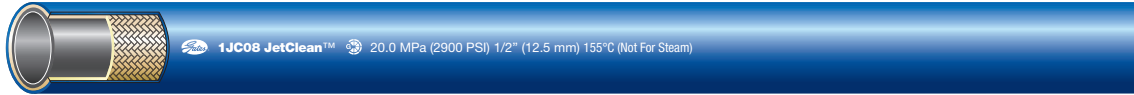

-size	mm	"	mm	MPa	MPa	mm	kg/100m	REF.
-4	6	1/4	13.5	20.0	90.0	50	22	1JC04
-5	8	5/16	15.1	20.0	86.0	55	25	1JC05
-6	10	3/8	17.1	20.0	72.0	65	32	1JC06
-5	8	5/16	15.1	20.0	86.0	55	25	1JC05B
-6	10	3/8	17.1	20.0	72.0	65	32	1JC06B
-8	13	1/2	20.3	20.0	64.0	90	41	1JC08B
-6	10	3/8	17.1	20.0	72.0	65	32	1JC06G
-8	13	1/2	20.3	20.0	64.0	90	41	1JC08G

RECOMMENDED FOR

Use on hot and cold water high pressure cleaning equipment where heavy-duty service is required. Suited for agricultural, sports, valet and maintenance service applications.

TUBE

NBR (Nitrile) based.

REINFORCEMENT

One wire braid.

COVER

NBR/PVC based. Available in black, blue (B) and grey (G).

TEMPERATURE RANGE

-40°C to +155°C.

STANDARDS

Gates proprietary.

COUPLINGS

MegaCrimp®.

CHARACTERISTICS/BENEFITS

Grey and blue JetClean™ are suitable for use in hospitals, swimming pools and other applications where hygiene is of the utmost importance.

Premium temperature resistance up to +155°C.

IMPORTANT



Not recommended for steam service.

INDUSTRIAL HOSE CLEANING

CLEAN MASTER™ PRESSURE WASH FORMERLY POWERCLEAN

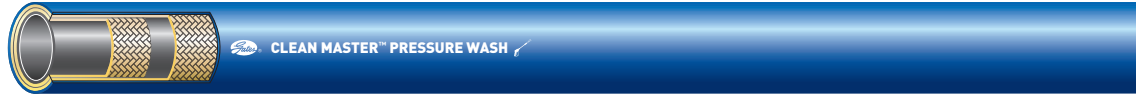

↔		○	○	⌚	🌪️	👤	📊	📏
-size	mm	"	mm	MPa	MPa	mm	kg/100m	REF.
-4	6	1/4	13.5	24.0	90.0	100	23	CLEAN MASTER PRESSURE WASH 3500 1WB 1/4"
-5	8	5/16	15.1	25.0	100.0	130	23	CLEAN MASTER PRESSURE WASH 3600 1WB 5/16"
-5	8	5/16	16.3	35.0	132.0	130	40	CLEAN MASTER PRESSURE WASH 5000 2WB 5/16"
-6	10	3/8	17.2	21.0	84.0	130	33	CLEAN MASTER PRESSURE WASH 3000 1WB 3/8"
-6	10	3/8	18.8	35.0	132.0	130	52	CLEAN MASTER PRESSURE WASH 5000 2WB 3/8"
-5	8	5/16	15.1	25.0	100.0	130	23	CLEAN MASTER PRESSURE WASH 3600B 1WB 5/16"
-5	8	5/16	16.3	35.0	132.0	130	40	CLEAN MASTER PRESSURE WASH 5000B 2WB 5/16"
-6	10	3/8	17.2	21.0	84.0	130	33	CLEAN MASTER PRESSURE WASH 3000B 1WB 3/8"
-6	10	3/8	18.8	35.0	132.0	130	52	CLEAN MASTER PRESSURE WASH 5000B 2WB 3/8"
-8	13	1/2	20.3	17.5	64.0	180	43	CLEAN MASTER PRESSURE WASH 2500B 1WB 1/2"
-8	13	1/2	21.8	28.0	110.0	180	62	CLEAN MASTER PRESSURE WASH 4000B 2WB 1/2"
-6	10	3/8	17.2	21.0	84.0	130	33	CLEAN MASTER PRESSURE WASH 3000G 1WB 3/8"
-6	10	3/8	18.8	35.0	132.0	130	52	CLEAN MASTER PRESSURE WASH 5000G 2WB 3/8"
-8	13	1/2	20.3	17.5	64.0	180	43	CLEAN MASTER PRESSURE WASH 2500G 1WB 1/2"

RECOMMENDED FOR

Use on pressure cleaning equipment. Specially compounded to handle high pressure water service.

TUBE

Type C (Nitrile), black.

REINFORCEMENT

One or two braid of high tensile steel wire.

COVER

C2 (Modified Nitrile). Available in black, blue (B) and grey (G). Blue and grey covers are nonmarking.

TEMPERATURE RANGE

-40°C to +121°C.

STANDARDS

Gates proprietary.

COUPLINGS

MegaCrimp®.

BRANDING TRANSFER LABEL

GATES® CLEAN MASTER™ PRESSURE WASH (2500-5000) NOT FOR STEAM SERVICE MADE IN U.S.A.

IMPORTANT











Not recommended for steam service.

INDUSTRIAL HOSE PETROLEUM TRANSFER

THE WORLD OF HOSE

PREMIUM™ FUEL MASTER D



								
mm	mm	mm	MPa	MPa	mm	kg/100m	m	REF.
19	31	6.0	2.0	8.0	133	60	40	FUEL MAS D 19mm x CL40
19	31	6.0	2.0	8.0	133	60	61*	FUEL MAS D 19mm x CL61
25	37	6.0	2.0	8.0	175	80	40	FUEL MAS D 25mm x CL40
25	37	6.0	2.0	8.0	175	80	61*	FUEL MAS D 25mm x CL61
32	44	6.0	2.0	8.0	224	90	40	FUEL MAS D 32mm x CL40
32	44	6.0	2.0	8.0	224	90	61*	FUEL MAS D 32mm x CL61
38	51	6.5	2.0	8.0	266	120	40	FUEL MAS D 38mm x CL40
38	51	6.5	2.0	8.0	266	120	61*	FUEL MAS D 38mm x CL61
50	66	8.0	2.0	8.0	350	160	40	FUEL MAS D 50mm x CL40
51	67	8.0	2.0	8.0	357	160	40	FUEL MAS D 51mm x CL40
51	67	8.0	2.0	8.0	357	160	61*	FUEL MAS D 51mm x CL61
63	79	8.0	2.0	8.0	441	210	40	FUEL MAS D 63mm x CL40
75	91	8.0	2.0	8.0	525	240	40	FUEL MAS D 75mm x CL40
76	92	8.0	2.0	8.0	532	250	40	FUEL MAS D 76mm x CL40
76	92	8.0	2.0	8.0	532	250	61*	FUEL MAS D 76mm x CL61
100	116	8.0	2.0	8.0	700	340	40	FUEL MAS D 100mm x CL40
102	118	8.0	2.0	8.0	714	350	40	FUEL MAS D 102mm x CL40
102	118	8.0	2.0	8.0	714	350	61*	FUEL MAS D 102mm x CL61
152	172	10.0	2.0	8.0	1050	680	40	FUEL MAS D 152mm x CL40

* 61 m coils are made to order

RECOMMENDED FOR

Premium pressure hose (D) for mineral oil products and fuel mixtures with a maximum 50% aromatic content. Ideal for offshore/onshore transfer applications involving discharge service for diesel oils and other similar petroleum products where an extremely lightweight, flexible hose with a high rated working pressure and a small minimum bend radius is required.

TUBE

Black NBR1 rubber, smooth and oil resistant.

REINFORCEMENT

High tensile synthetic textile cord, two crossing anti-static wires.

COVER

CR rubber, black, smooth with cloth impression, good resistance to weather and abrasion, chemical and oil resistance.

TEMPERATURE RANGE

-30°C to +90°C.

BURST PRESSURE

4 x WP.

ELECTRICALLY CONDUCTIVE

$R < 10^6 \text{ Ohm}$.

STANDARDS

EN 12115, EN 1761.

BRANDING TRANSFER LABEL

PREMIUM™ FUEL MASTER D - EN 12115/ EN 1761 FUEL TRANSFER 20 BAR D









BRANDING EMBOSSED LABEL

GATES PREMIUM™ FUEL MASTER D - EN 12115/ EN 1761 NBR1 - DIAM mm - 20 BAR - D - Q - year

INDUSTRIAL HOSE PETROLEUM TRANSFER

PREMIUM™ FUEL MASTER SD



								
mm	mm	mm	MPa	MPa	mm	kg/100m	m	REF.
19	31	6.0	1.6	6.4	105	70	40	FUEL MAS SD 19mm x CL40
19	31	6.0	1.6	6.4	105	70	61*	FUEL MAS SD 19mm x CL61
25	37	6.0	1.6	6.4	138	80	40	FUEL MAS SD 25mm x CL40
25	37	6.0	1.6	6.4	138	80	61*	FUEL MAS SD 25mm x CL61
32	44	6.0	1.6	6.4	176	110	40	FUEL MAS SD 32mm x CL40
32	44	6.0	1.6	6.4	176	110	61*	FUEL MAS SD 32mm x CL61
38	51	6.5	1.6	6.4	209	130	40	FUEL MAS SD 38mm x CL40
38	51	6.5	1.6	6.4	209	130	61*	FUEL MAS SD 38mm x CL61
50	66	8.0	1.6	6.4	275	230	40	FUEL MAS SD 50mm x CL40
51	67	8.0	1.6	6.4	281	230	40	FUEL MAS SD 51mm x CL40
51	67	8.0	1.6	6.4	281	230	61*	FUEL MAS SD 51mm x CL61
63	79	8.0	1.6	6.4	347	290	40	FUEL MAS SD 63mm x CL40
75	91	8.0	1.6	6.4	413	330	40	FUEL MAS SD 75mm x CL40
76	92	8.0	1.6	6.4	418	330	40	FUEL MAS SD 76mm x CL40
76	92	8.0	1.6	6.4	418	330	61*	FUEL MAS SD 76mm x CL61
100	116	8.0	1.6	6.4	550	440	40	FUEL MAS SD 100mm x CL40
102	118	8.0	1.6	6.4	561	450	40	FUEL MAS SD 102mm x CL40
102	118	8.0	1.6	6.4	561	450	61*	FUEL MAS SD 102mm x CL61
127	147	10.0	1.6	6.4	688	690	40	FUEL MAS SD 127mm x CL40
152	174	11.0	1.6	6.4	825	960	40	FUEL MAS SD 152mm x CL40

* 61 m coils are made to order ** Vacuum resistance up to -0.9 bar

RECOMMENDED FOR

Premium vacuum and pressure hose (SD) for mineral oil products and fuel mixtures with maximum 50% aromatic content. Ideal for offshore/onshore transfer applications involving suction and discharge service for diesel oils and other similar petroleum products where an extremely lightweight, hard wall, flexible hose with a high rated working pressure and a small minimum bend radius is required.

TUBE

Black NBR1 rubber, smooth and oil resistance.

REINFORCEMENT

High tensile synthetic textile cord, steel wire helix and two crossing anti-static wires.

COVER

CR rubber, black, smooth with cloth impression, good resistance to weather and abrasion, chemical and oil resistance.

TEMPERATURE RANGE

-30°C to +90°C.

BURST PRESSURE

4 x WP.

ELECTRICALLY CONDUCTIVE

$R < 10^6$ Ohm.

STANDARDS

EN 12115, EN 1761.

BRANDING TRANSFER LABEL

PREMIUM™ FUEL MASTER SD - EN 12115/ EN 1761 – FUEL TRANSFER 16 BAR Q

BRANDING EMBOSSED LABEL









GATES PREMIUM™ FUEL MASTER SD - EN 12115/ EN 1761 – NBR 1 - DIAM mm - 16 BAR - Q - Q - year

INDUSTRIAL HOSE PETROLEUM TRANSFER

THE WORLD OF HOSE

ESSENTIAL™ OIL MASTER SD



								
mm	mm	mm	MPa	MPa	mm	kg/100m	m	REF.
19	29	5.0	1.0	3.0	95	50	40	OIL MAS SD 19mm x CL40
25	35	5.0	1.0	3.0	125	60	40	OIL MAS SD 25mm x CL40
32	42	5.0	1.0	3.0	160	90	40	OIL MAS SD 32mm x CL40
38	48	5.0	1.0	3.0	190	100	40	OIL MAS SD 38mm x CL40
50	60	5.0	1.0	3.0	250	140	40	OIL MAS SD 50mm x CL40
65	77	6.0	1.0	3.0	325	230	40	OIL MAS SD 65mm x CL40
75	88	6.5	1.0	3.0	375	270	40	OIL MAS SD 75mm x CL40
100	114	7.0	1.0	3.0	500	390	40	OIL MAS SD 100mm x CL40
125	141	8.0	1.0	3.0	625	600	40	OIL MAS SD 125mm x CL40
152	168	8.0	1.0	3.0	750	790	40	OIL MAS SD 152mm x CL40

** Vacuum resistance up to -0.9 bar

RECOMMENDED FOR

Vacuum and pressure hose (SD) for transfer of fuel oil and other petroleum based products in home delivery, commercial and industrial service or in low pressure return lines. Transfer of refined fuels (commercial gasoline and diesel fuel), oils and other petroleum products. Ideal for oilfield service truck use. Service life of transfer hoses can be extended by draining hoses after use. Max 50% aromatic content.

TUBE

Black NBR rubber, smooth and oil resistant.

REINFORCEMENT

High tensile synthetic textile cord, steel wire helix, two crossing anti-static wires.

COVER

CR rubber, black, smooth with cloth impression, good resistance to weather and abrasion, chemical and oil resistance.

TEMPERATURE RANGE

-30°C to +100°C.

BURST PRESSURE

> 30 bar.

ELECTRICALLY CONDUCTIVE

R < 10⁶ Ohm.

BRANDING TRANSFER LABEL

ESSENTIAL™ OIL MASTER SD - 10 BAR Ω

INDUSTRIAL HOSE PETROLEUM TRANSFER

ESSENTIAL™ OIL MASTER LITE SD



mm	mm	mm	MPa	MPa	mm	kg/100m	m	REF.
19	29	5.0	1.0	3.0	95	50	40	OIL MAS Lite SD 19mm x CL40
25	35	5.0	1.0	3.0	125	60	40	OIL MAS Lite SD 25mm x CL40
32	42	5.0	1.0	3.0	160	90	40	OIL MAS Lite SD 32mm x CL40
38	48	5.0	1.0	3.0	190	100	40	OIL MAS Lite SD 38mm x CL40
51	61	5.0	1.0	3.0	255	140	40	OIL MAS Lite SD 51mm x CL40
65	77	6.0	1.0	3.0	325	230	40	OIL MAS Lite SD 65mm x CL40
76	88	6.0	1.0	3.0	380	270	40	OIL MAS Lite SD 76mm x CL40
90	104	7.0	1.0	3.0	450	350	40	OIL MAS Lite SD 90mm x CL40
100	114	7.0	1.0	3.0	500	390	40	OIL MAS Lite SD 100mm x CL40
127	143	8.0	1.0	3.0	635	610	40	OIL MAS Lite SD 127mm x CL40
152	168	8.0	1.0	3.0	760	790	40	OIL MAS Lite SD 152mm x CL40

** Vacuum resistance up to -0.9 bar

RECOMMENDED FOR

Very flexible corrugated vacuum and pressure hose (SD) for transfer of fuel oil and other petroleum based products in home delivery, commercial and industrial service or in low pressure return lines. Transfer of refined fuels (commercial gasoline and diesel fuel), oils and other petroleum products. Ideal for oilfield service truck use. Service life of transfer hoses can be extended by draining hoses after use. Max 50% aromatic content.

TUBE

Black NBR rubber, smooth and oil resistant.

REINFORCEMENT

High tensile synthetic textile cord, steel wire helix and two crossing anti-static wires.

COVER

CR rubber, black, corrugated with cloth impression, good resistance to weather and abrasion, chemical and oil resistance.

TEMPERATURE RANGE

-30°C to 100°C.

BURST PRESSURE

> 30 bar.

ELECTRICALLY CONDUCTIVE

R < 10⁶ Ohm.

COUPLINGS

-12 to -20: MegaCrimp®; -24: GlobalSpiral Plus.

BRANDING TRANSFER LABEL

ESSENTIAL™ OIL MASTER LITE SD - 10 BAR Ω

INDUSTRIAL HOSE PETROLEUM TRANSFER

THE WORLD OF HOSE

ESSENTIAL™ REEL MASTER D











mm	mm	mm	MPa	MPa	mm	kg/100m	m	REF.
25	35	5.0	1.6	4.8	175	70	61	REEL MAS D 25mm x CL61
32	43	5.5	1.6	4.8	224	80	61	REEL MAS D 32mm x CL61
35	46	5.5	1.6	4.8	245	90	61	REEL MAS D 35mm x CL61
38	50	6.0	1.6	4.8	266	110	61	REEL MAS D 38mm x CL61
40	52	6.0	1.6	4.8	280	110	61	REEL MAS D 40mm x CL61
51	65	7.0	1.6	4.8	357	190	61	REEL MAS D 51mm x CL61

RECOMMENDED FOR	Pressure domestic fuel reel hose for tank trucks and oil delivery in heavy duty reeling applications. Also suitable for tank cleaning.
TUBE	Black NBR rubber, smooth and oil resistant.
REINFORCEMENT	High tensile synthetic textile cord and two crossing anti-static wires.
COVER	CR rubber, black, smooth with cloth impression, good resistance to weather and abrasion, chemical and oil resistance.
TEMPERATURE RANGE	-30°C to +70°C.
BURST PRESSURE	48 bar.
ELECTRICALLY CONDUCTIVE	$R < 10^6$ Ohm.
STANDARDS	EN 1360, EN 1761.
BRANDING TRANSFER LABEL	ESSENTIAL™ REEL MASTER D - 16 BAR Ω

INDUSTRIAL HOSE PETROLEUM TRANSFER

ESSENTIAL™ BUNKER MASTER D



								
mm	mm	mm	MPa	MPa	kg/100m	m	REF.	
76	94	9.0	1.6	4.8	532	300	40	BUNKER MAS D 76mm x CL40
102	120	9.0	1.6	4.8	714	400	40	BUNKER MAS D 102mm x CL40
127	145	9.0	1.6	4.8	889	490	40	BUNKER MAS D 127mm x CL40
152	170	9.0	1.6	4.8	1064	500	40	BUNKER MAS D 152mm x CL40
203	223	10.0	1.6	4.8	1421	850	40	BUNKER MAS D 203mm x CL40
254	276	11.0	1.6	4.8	1778	1150	40	BUNKER MAS D 254mm x CL40









RECOMMENDED FOR	Ship-to-shore oil bunker delivery hose for crude oil and liquid petroleum products with a maximum of 50% aromatic content, for tankers and bunkering vessels.
TUBE	Black NBR rubber, smooth and oil resistant.
REINFORCEMENT	High tensile synthetic textile cord, two crossing anti-static wires.
COVER	CR rubber, black, smooth with cloth impression, good resistance to weather and abrasion, chemical and oil resistance.
TEMPERATURE RANGE	-30°C to +90°C.
BURST PRESSURE	48 bar.
ELECTRICALLY CONDUCTIVE	R < 10 ⁶ Ohm.
BRANDING TRANSFER LABEL	ESSENTIAL™ BUNKER MASTER D - 16 BAR Ω

INDUSTRIAL HOSE PETROLEUM TRANSFER

THE WORLD OF HOSE

PREMIUM™ TAR MASTER SD



								
mm	mm	mm	MPa	MPa	mm	kg/100m	m	REF.
25	39	7.0	1.8	7.2	175	110	40	TAR MAS SD 25mm x CL40
32	47	7.5	1.8	7.2	224	140	40	TAR MAS SD 32mm x CL40
38	54	8.0	1.8	7.2	266	180	40	TAR MAS SD 38mm x CL40
51	67	8.0	1.8	7.2	357	250	40	TAR MAS SD 51mm x CL40
63	81	9.0	1.4	5.6	441	340	40	TAR MAS SD 63mm x CL40
76	95	9.5	1.4	5.6	532	420	40	TAR MAS SD 76mm x CL40
102	123	10.5	1.4	5.6	714	610	40	TAR MAS SD 102mm x CL40









** Vacuum resistance up to -0.9 bar

RECOMMENDED FOR	Premium hose designed for the bulk transfer and delivery of hot petroleum products, such as tar, asphalt, and oil. This hose is designed for suction and discharge.
TUBE	Acrylic rubber with outstanding resistance to hot oil.
REINFORCEMENT	High tensile synthetic textile cord, steel wire helix, static wire.
COVER	CR based rubber, black, smooth with cloth impression, good resistance to weather and abrasion, chemical and oil resistance.
TEMPERATURE RANGE	-30°C to +160°C, intermittent up to +180°C.
BURST PRESSURE	4 x WP.
ELECTRICALLY CONDUCTIVE	R < 10 ⁶ Ohm.
BRANDING TRANSFER LABEL	PREMIUM™ TAR MASTER SD - HOT TAR & ASPHALT Ø

INDUSTRIAL HOSE STEAM

PREMIUM™ STEAM MASTER



								
mm	mm	mm	MPa	MPa	kg/100m	m	REF.	
13	25	6.0	1.8	18.0	91	50	40	STEAM MAS 13mm x CL40
16	30	7.0	1.8	18.0	112	70	40	STEAM MAS 16mm x CL40
19	33	7.0	1.8	18.0	133	80	40	STEAM MAS 19mm x CL40
25	40	7.5	1.8	18.0	175	110	40	STEAM MAS 25mm x CL40
32	48	8.0	1.8	18.0	224	150	40	STEAM MAS 32mm x CL40
38	54	8.0	1.8	18.0	266	180	40	STEAM MAS 38mm x CL40
51	67	8.0	1.8	18.0	357	230	40	STEAM MAS 51mm x CL40









RECOMMENDED FOR	Premium steam hose for the transport of pressurised saturated steam at +210°C up to a max. 18 bar working pressure or pressurised hot water.
TUBE	Black EPDM, smooth, conductive.
REINFORCEMENT	Two high tensile steel braids.
COVER	EPDM rubber, smooth, black, all sizes are pinpricked. Extremely weather resistant cover.
TEMPERATURE RANGE	-40°C to +210°C.
BURST PRESSURE	180 bar.
ELECTRICALLY CONDUCTIVE	$R < 10^6 \text{ Ohm}$.
STANDARDS	EN ISO 6134:2005-2A.
BRANDING TRANSFER LABEL	PREMIUM™ STEAM MASTER - EN ISO 6134:2005-2A STEAM 18 BAR 210°C Q - DRAIN AFTER USE
BRANDING EMBOSSED LABEL	GATES PREMIUM™ STEAM MASTER - EN ISO 6134:2005-2A STEAM 18 BAR - DIAM mm - Q - Q - year

INDUSTRIAL HOSE STEAM

THE WORLD OF HOSE

PREMIUM™ STEAM MASTER RED











								
mm	mm	mm	MPa	MPa	kg/100m	m	REF.	
13	25	6.0	1.8	18.0	91	50	40	STEAM MAS RED 13mm x CL40
16	30	7.0	1.8	18.0	112	70	40	STEAM MAS RED 16mm x CL40
19	33	7.0	1.8	18.0	133	80	40	STEAM MAS RED 19mm x CL40
25	40	7.5	1.8	18.0	175	110	40	STEAM MAS RED 25mm x CL40
32	48	8.0	1.8	18.0	224	150	40	STEAM MAS RED 32mm x CL40
38	54	8.0	1.8	18.0	266	180	40	STEAM MAS RED 38mm x CL40
51	67	8.0	1.8	18.0	357	230	40	STEAM MAS RED 51mm x CL40

RECOMMENDED FOR	Premium steam hose for the transport of pressurised saturated steam at +210°C up to a max. 18 bar working pressure or pressurised hot water.
TUBE	Black EPDM, smooth, conductive.
REINFORCEMENT	Two high tensile steel braids.
COVER	EPDM rubber, smooth, red, all sizes are pinpricked. Extremely weather resistant cover.
TEMPERATURE RANGE	-40°C to +210°C.
BURST PRESSURE	180 bar.
ELECTRICALLY CONDUCTIVE	Liner R < 10 ⁶ Ohm.
STANDARDS	EN ISO 6134:2005-2A.
BRANDING TRANSFER LABEL	PREMIUM™ STEAM MASTER RED - EN ISO 6134:2005-2A STEAM 18 BAR 210°C - DRAIN AFTER USE
BRANDING EMBOSSED LABEL	GATES PREMIUM™ STEAM MASTER RED - EN ISO 6134:2005-2A STEAM 18 BAR - DIAM mm - Q - year

INDUSTRIAL HOSE STEAM

PREMIUM™ HEATER MASTER



			 steam	 water					
mm	mm	mm	MPa	MPa	MPa	kg/100m	m	REF.	
13	25	6.0	0.6	2.0	6.0	91	50	40	HEATER MAS 13mm x CL40
16	30	7.0	0.6	2.0	6.0	112	60	40	HEATER MAS 16mm x CL40
19	33	7.0	0.6	2.0	6.0	133	80	40	HEATER MAS 19mm x CL40
25	40	7.5	0.6	2.0	6.0	175	90	40	HEATER MAS 25mm x CL40
32	48	8.0	0.6	2.0	6.0	224	120	40	HEATER MAS 32mm x CL40
38	54	8.0	0.6	2.0	6.0	266	140	40	HEATER MAS 38mm x CL40
51	67	8.0	0.6	2.0	6.0	357	180	40	HEATER MAS 51mm x CL40









RECOMMENDED FOR	Premium hot water (20 bar up to +90°C) delivery and steam hose up to +164°C, 6 bar working pressure in general industrial applications.
TUBE	Black EPDM, smooth.
REINFORCEMENT	High tensile textile cord.
COVER	EPDM rubber, smooth, black. Extremely weather resistant cover.
TEMPERATURE RANGE	-20°C to +164°C.
BURST PRESSURE	60 bar.
ELECTRICALLY CONDUCTIVE	$R < 10^6$ Ohm.
STANDARDS	Exceeds BS 5122/A2.
BRANDING TRANSFER LABEL	PREMIUM™ HEATER MASTER - STEAM OPEN SYSTEM 6 BAR 164°C Ω

INDUSTRIAL HOSE ACID-CHEMICAL

THE WORLD OF HOSE

PREMIUM™ CHEM MASTER XLPE SD



								
mm	mm	mm	MPa	MPa	mm	kg/100m	m	REF.
19	31	6.0	1.6	4.8	95	70	40	CHEM MAS XLPE SD 19mm x CL40
25	37	6.0	1.6	4.8	125	80	40	CHEM MAS XLPE SD 25mm x CL40
32	44	6.0	1.6	4.8	160	100	40	CHEM MAS XLPE SD 32mm x CL40
38	51	6.5	1.6	4.8	190	120	40	CHEM MAS XLPE SD 38mm x CL40
50	66	8.0	1.6	4.8	250	210	40	CHEM MAS XLPE SD 50mm x CL40
51	67	8.0	1.6	4.8	255	220	40	CHEM MAS XLPE SD 51mm x CL40
65	81	8.0	1.6	4.8	325	260	40	CHEM MAS XLPE SD 65mm x CL40
75	91	8.0	1.6	4.8	375	310	40	CHEM MAS XLPE SD 75mm x CL40
76	92	8.0	1.6	4.8	380	310	40	CHEM MAS XLPE SD 76mm x CL40
100	116	8.0	1.6	4.8	500	410	40	CHEM MAS XLPE SD 100mm x CL40

** Vacuum resistance up to -0.9 bar

RECOMMENDED FOR

Premium hose for tank truck, barge, ship, or storage tank transfer applications of a variety of chemical products. The hose contains a wire helix for full suction capability, as well as for routing hoses through tight bends. A heavy duty suction and discharge hose (SD) for use with various acids and chemicals.

TUBE

XLPE, black smooth.

REINFORCEMENT

High tensile synthetic textile cord, steel wire helix and crossing anti-static wires.

COVER

EPDM rubber, smooth, green. Extremely weather resistant cover.

TEMPERATURE RANGE

-20°C to +65°C.

BURST PRESSURE

> 48 bar.









BRANDING TRANSFER LABEL

PREMIUM™ CHEM MASTER XLPE SD – CHEMICAL TRANSFER 16 BAR

INDUSTRIAL HOSE ACID-CHEMICAL

PREMIUM™ CHEM MASTER EPDM D



								
mm	mm	mm	MPa	MPa	mm	kg/100m	m	REF.
13	25	6.0	1.6	6.4	91	50	40	CHEM MAS EPDM D 13mm x CL40
19	31	6.0	1.6	6.4	133	60	40	CHEM MAS EPDM D 19mm x CL40
22	34	6.0	1.6	6.4	154	70	40	CHEM MAS EPDM D 22mm x CL40
25	37	6.0	1.6	6.4	175	70	40	CHEM MAS EPDM D 25mm x CL40
32	44	6.0	1.6	6.4	224	90	40	CHEM MAS EPDM D 32mm x CL40
38	51	6.5	1.6	6.4	266	120	40	CHEM MAS EPDM D 38mm x CL40
50	66	8.0	1.6	6.4	350	180	40	CHEM MAS EPDM D 50mm x CL40
51	67	8.0	1.6	6.4	357	180	40	CHEM MAS EPDM D 51mm x CL40
63	79	8.0	1.6	6.4	441	220	40	CHEM MAS EPDM D 63mm x CL40
75	91	8.0	1.6	6.4	525	260	40	CHEM MAS EPDM D 75mm x CL40
76	92	8.0	1.6	6.4	532	270	40	CHEM MAS EPDM D 76mm x CL40
100	116	8.0	1.6	6.4	700	350	40	CHEM MAS EPDM D 100mm x CL40
102	118	8.0	1.6	6.4	714	350	40	CHEM MAS EPDM D 101.5mm x CL40

RECOMMENDED FOR

Premium delivery hose (D) for handling a variety of chemical products such as acids, alkalis, esters and ketones with a medium or low concentration. Tank truck, barge, ship, or storage tank transfer of a variety of mild chemical products.

TUBE

Black EPDM, smooth, conductive.

REINFORCEMENT

High tensile synthetic textile cord with crossing anti-static wires.

COVER

CSM rubber, black, superior resistance to weather and abrasion, excellent chemical and oil resistance.

TEMPERATURE RANGE

-40°C to +95°C.

BURST PRESSURE

4 x WP.

ELECTRICALLY CONDUCTIVE

$R < 10^6$ Ohm.

STANDARDS

EN 12115.

BRANDING TRANSFER LABEL

PREMIUM™ CHEM MASTER EPDM D - EN 12115 CHEMICAL TRANSFER 16 BAR Ω

BRANDING EMBOSSED LABEL









GATES PREMIUM™ CHEM MASTER EPDM D - EN 12115 - EPDM - DIAM .. - 16 BAR - Ω - Q - year

INDUSTRIAL HOSE ACID-CHEMICAL

THE WORLD OF HOSE

PREMIUM™ CHEM MASTER EPDM SD



								
mm	mm	mm	MPa	MPa	mm	kg/100m	m	REF.
19	31	6.0	1.6	6.4	95	70	40	CHEM MAS EPDM SD 19mm x CL40
25	37	6.0	1.6	6.4	125	90	40	CHEM MAS EPDM SD 25mm x CL40
32	44	6.0	1.6	6.4	160	100	40	CHEM MAS EPDM SD 32mm x CL40
38	51	6.5	1.6	6.4	190	130	40	CHEM MAS EPDM SD 38mm x CL40
50	66	8.0	1.6	6.4	250	220	40	CHEM MAS EPDM SD 50mm x CL40
51	67	8.0	1.6	6.4	255	220	40	CHEM MAS EPDM SD 51mm x CL40
63	79	8.0	1.6	6.4	315	280	40	CHEM MAS EPDM SD 63mm x CL40
75	91	8.0	1.6	6.4	375	320	40	CHEM MAS EPDM SD 75mm x CL40
76	92	8.0	1.6	6.4	380	330	40	CHEM MAS EPDM SD 76mm x CL40
100	116	8.0	1.6	6.4	500	430	40	CHEM MAS EPDM SD 100mm x CL40
102	118	8.0	1.6	6.4	508	430	40	CHEM MAS EPDM SD 101.5mm x CL40
152	174	11.0	1.6	6.4	750	900	40	CHEM MAS EPDM SD 150mm x CL40

** Vacuum resistance up to -0.9 bar

RECOMMENDED FOR

Premium suction and discharge hose (SD) for handling a variety of chemical products such as acids, alkalis, esters and ketones with a medium or low concentration. Tank truck, barge, ship, or storage tank transfer of a variety of mild chemical products.

TUBE

Black EPDM, smooth, conductive.

REINFORCEMENT

High tensile synthetic textile cord, steel wire helix with crossing anti-static wires.

COVER

CSM rubber, black, superior resistance to weather and abrasion, excellent chemical and oil resistance.

TEMPERATURE RANGE

-40°C to +95°C.

BURST PRESSURE

4 x WP.

ELECTRICALLY CONDUCTIVE

$R < 10^6 \text{ Ohm}$.

STANDARDS

EN 12115.

BRANDING TRANSFER LABEL

PREMIUM™ CHEM MASTER EPDM SD - EN 12115 CHEMICAL TRANSFER 16 BAR Ω

BRANDING EMBOSSED LABEL

GATES PREMIUM™ CHEM MASTER EPDM SD - EN 12115 - EPDM - DIAM .. - 16 BAR - Ω - Q - year

INDUSTRIAL HOSE ACID-CHEMICAL

PREMIUM™ CHEM MASTER UHMWPE SD



mm	mm	mm	MPa	MPa	mm	kg/100m	m	REF.
13	23	5.0	1.6	6.4	65	40	40	CHEM MAS UHMWPE SD 13mm x CL40
19	31	6.0	1.6	6.4	95	70	40	CHEM MAS UHMWPE SD 19mm x CL40
25	37	6.0	1.6	6.4	125	80	40	CHEM MAS UHMWPE SD 25mm x CL40
32	44	6.0	1.6	6.4	160	100	40	CHEM MAS UHMWPE SD 32mm x CL40
38	51	6.5	1.6	6.4	190	120	40	CHEM MAS UHMWPE SD 38mm x CL40
50	66	8.0	1.6	6.4	250	210	40	CHEM MAS UHMWPE SD 50mm x CL40
51	67	8.0	1.6	6.4	255	220	40	CHEM MAS UHMWPE SD 51mm x CL40
63	79	8.0	1.6	6.4	315	260	40	CHEM MAS UHMWPE SD 63mm x CL40
75	91	8.0	1.6	6.4	375	310	40	CHEM MAS UHMWPE SD 75mm x CL40
100	116	8.0	1.6	6.4	500	410	40	CHEM MAS UHMWPE SD 100mm x CL40
102	118	8.0	1.6	6.4	508	420	40	CHEM MAS UHMWPE SD 101.5mm x CL40

** Vacuum resistance up to -0.9 bar

RECOMMENDED FOR

Very universal suction and discharge hose (SD) capable of handling a wide spectrum of corrosive chemicals and acids. Tank truck, barge, ship, or storage tank transfer of a variety of chemical products. The hose contains a wire helix for full suction capability.

TUBE

UHMWPE, black, smooth and conductive.

REINFORCEMENT

High tensile synthetic textile cord, steel wire helix and crossing anti-static wires.

COVER

CSM rubber, black, superior resistance to weather and abrasion, excellent chemical and oil resistance.

TEMPERATURE RANGE

-35°C to +100°C, suitable for steam at +130°C with intermittent usage.

BURST PRESSURE

4 x WP.

ELECTRICALLY CONDUCTIVE

$R < 10^6$ Ohm.

STANDARDS

EN 12115.

BRANDING TRANSFER LABEL

PREMIUM™ CHEM MASTER UHMWPE SD - EN12115 CHEMICAL TRANSFER 16 BAR Q

BRANDING EMBOSSED LABEL

GATES PREMIUM™ CHEM MASTER UHMWPE SD – EN 12115 - UHMWPE - DIAM .. - 16 BAR - Q – Q - year







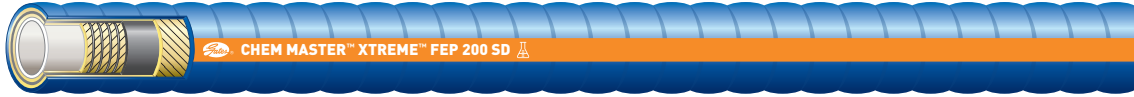

INDUSTRIAL HOSE

ACID-CHEMICAL

THE WORLD OF HOSE

CHEM MASTER™ XTREME™ FEP (125-200) SD FORMERLY STALLION® HOSE



								
mm	mm	mm	MPa	MPa	mm	kg/100m	m	REF.
19	33	6.9	1.3	5.5	102	80	30.5	CHEM MAS XTRM FEP SD 3/4"
25	40	7.1	1.3	5.5	127	100	30.5	CHEM MAS XTRM FEP SD 1"
38	52	7.0	1.3	5.5	203	140	30.5	CHEM MAS XTRM FEP SD 1.1/2"
51	65	7.0	1.3	5.5	229	180	30.5	CHEM MAS XTRM FEP SD 2"
64	78	7.3	1.3	5.5	305	220	30.5	CHEM MAS XTRM FEP SD 2.1/2"
76	91	7.5	1.3	5.5	457	270	30.5	CHEM MAS XTRM FEP SD 3"
102	118	8.4	1.3	5.5	610	410	30.5	CHEM MAS XTRM FEP SD 4"

** Vacuum resistance up to -0.9 bar

RECOMMENDED FOR

Tank truck, barge, ship, or storage tank transfer of a variety of chemical products. With wire helix for full suction capability. The tube stock (Teflon* or Neoflon**) has excellent chemical resistance and is backed by Gates Gatron™ for flex fatigue safety at the coupling. Designed for easy cleaning in a bath containing 10% (NaOH) @ +100°C. Cleaning in place (CIP) methods may be used. Applications include most basic chemicals which are building blocks for numerous chemicals used in a variety of industries. Compatible with commercially available Bio-Diesel fuels up to B-100.

TUBE

Type T (FEP) Teflon* or Neoflon**, white. Backed with Gatron™ (Modified XLPE).

REINFORCEMENT

Synthetic, high tensile textile with steel wire helix.

COVER

Type P (EPDM), blue corrugated with orange spiral stripe.

TEMPERATURE RANGE

-40°C to +149°C normal service. Designed to withstand fluid temperatures to +149°C, however the rating is dependent on the specific chemical conveyed.

BURST PRESSURE

55 bar.

BRANDING TRANSFER LABEL

Continuous transfer label. Example: "GATES® CHEM MASTER™ XTREME™ FEP (125-200)SD U.S. PAT. NO. 5,647,400 ACID-CHEMICAL SUCTION/DISCHARGE 200 PSI (1.38MPa) WP MADE IN U.S.A." For your safety: Use Permanent Fittings Only

IMPORTANT



Use of Damaged Hose Could be Hazardous.









* Teflon® is a Registered Trademark of DuPont.

** Neoflon® is a Registered Trademark of Daikin.

INDUSTRIAL HOSE ACID-CHEMICAL

CHEM MASTER™ PAINT SPRAY FORMERLY 77B PAINT SPRAY AND CHEMICAL



								
mm	mm	mm	MPa	MPa	mm	kg/100m	m	REF.
6	13	3.4	3.5	13.8	76	13	182.9-243.8m	CHEM MAS PAINT SPRAY 1/4"
8	15	3.6	3.5	13.8	76	16	182.9-243.8m	CHEM MAS PAINT SPRAY 5/16"
10	17	3.8	3.5	13.8	76	21	182.9-243.8m	CHEM MAS PAINT SPRAY 3/8"
13	22	4.7	5.2	20.7	127	34	182.9-243.8m	CHEM MAS PAINT SPRAY 1/2"
19	30	5.2	5.2	20.7	152	52	91.44-121.9m	CHEM MAS PAINT SPRAY 3/4"

RECOMMENDED FOR

Paint spray applications, as well as transfer of petroleum based products (aliphatic, aromatic and chlorinated hydrocarbon such as Toluene, Xylene, Benzene, gasoline and carbon tetrachloride). Compatible with commercially available Bio-Diesel fuels up to B-100.

TUBE

Type Z (special flexible nylon 11), clear.

REINFORCEMENT

Synthetic, high tensile textile cord.

COVER

Type A (neoprene), black.

TEMPERATURE RANGE

-40°C to +66°C continuous service.

BURST PRESSURE

> 138 bar.

BRANDING TRANSFER LABEL

GATES® CHEM MASTER™ PAINT SPRAY (500-750) 3/8" (9.5MM) 500 PSI (3.45MPa) WP MADE IN U.S.A.

NOTE

Contact Gates when conveying chemicals above +49°C.

IMPORTANT











Not recommended for acids or use in high pressure paint spray applications requiring a static conductive hose.

INDUSTRIAL HOSE FOOD & BEVERAGE

THE WORLD OF HOSE

PREMIUM™ DAIRY MASTER SD



								
mm	mm	mm	MPa	MPa	mm	kg/100m	m	REF.
32	44	6.0	1.0	3.0	160	100	40	DAIRY MAS SD 32mm x CL40
38	50	6.0	1.0	3.0	190	120	40	DAIRY MAS SD 38mm x CL40
40	52	6.0	1.0	3.0	200	130	40	DAIRY MAS SD 40mm x CL40
45	59	7.0	1.0	3.0	225	150	40	DAIRY MAS SD 45mm x CL40
51	65	7.0	1.0	3.0	255	200	40	DAIRY MAS SD 51mm x CL40
63	77	7.0	1.0	3.0	315	240	40	DAIRY MAS SD 63mm x CL40
76	90	7.0	1.0	3.0	380	310	40	DAIRY MAS SD 76mm x CL40
102	118	8.0	1.0	3.0	510	480	40	DAIRY MAS SD 102mm x CL40

** Vacuum resistance up to -0.9 bar

RECOMMENDED FOR

Premium vacuum and pressure hose (SD) for food products. Tank truck, barge, ship, or storage tank transfer of a variety of food products such as animal fat, vegetable oil and other edible oils requiring an FDA sanitary hose. Also suitable for ice cream and other dairy products.

TUBE

NBR based white food quality rubber, resistant to animal fat and vegetable oils.

REINFORCEMENT

Synthetic, high tensile textile with steel wire helix.

COVER

NBR based rubber, blue, resistant to animal fat and vegetable oils.

TEMPERATURE RANGE

-30°C to +90°C, intermittent up to +130°C / 30 minutes for cleaning.

BURST PRESSURE

> 30 bar.

STANDARDS

FDA, animal derived ingredient free.









BRANDING TRANSFER LABEL

PREMIUM™ DAIRY MASTER SD - FOOD 10 BAR

INDUSTRIAL HOSE FOOD & BEVERAGE

PREMIUM™ DAIRY MASTER LITE SD



								
mm	mm	mm	MPa	MPa	mm	kg/100m	m	REF.
32	43	5.5	1.0	3.0	88	87	40	DAIRY MAS lite SD 32mm x CL40
38	49	5.5	1.0	3.0	104	101	40	DAIRY MAS lite SD 38mm x CL40
40	51	5.5	1.0	3.0	110	105	40	DAIRY MAS lite SD 40mm x CL40
45	56	5.5	1.0	3.0	124	120	40	DAIRY MAS lite SD 45mm x CL40
51	63	6.0	1.0	3.0	140	145	40	DAIRY MAS lite SD 51mm x CL40
63	76	6.5	1.0	3.0	173	182	40	DAIRY MAS lite SD 63mm x CL40
76	89	6.5	1.0	3.0	209	216	40	DAIRY MAS lite SD 76mm x CL40
102	116	7.0	1.0	3.0	306	351	40	DAIRY MAS lite SD 102mm x CL40

** Vacuum resistance up to -0.9 bar

RECOMMENDED FOR

Very flexible corrugated vacuum and pressure hose (SD) for food products. Tank truck, barge, ship, or storage tank transfer of a variety of food products such as animal fat, vegetable oil and other edible oils requiring an FDA sanitary hose. Also suitable for ice cream and other dairy products.

TUBE

NBR based white food quality rubber, resistant to animal fat and vegetable oils.

REINFORCEMENT

Synthetic, high tensile textile with steel wire helix.

COVER

NBR based rubber, blue, corrugated and resistant to animal fat and vegetable oils.

TEMPERATURE RANGE

-30°C to +90°C, intermittent up to +130°C / 30 minutes for cleaning.

BURST PRESSURE

> 30 bar.

STANDARDS

FDA, animal derived ingredient free.

BRANDING TRANSFER LABEL









PREMIUM™ DAIRY MASTER LITE SD - FOOD 10 BAR

INDUSTRIAL HOSE FOOD & BEVERAGE

THE WORLD OF HOSE

PREMIUM™ WASHDOWN MASTER



								REF.
mm	mm	mm	MPa	MPa	mm	kg/100m	m	
10	18	4.0	0.6	6.0	70	20	40	WASHDOWN MAS 10mm x CL40
13	23	5.0	0.6	6.0	91	40	40	WASHDOWN MAS 13mm x CL40
16	26	5.0	0.6	6.0	112	40	40	WASHDOWN MAS 16mm x CL40
19	31	6.0	0.6	6.0	133	60	40	WASHDOWN MAS 19mm x CL40
25	37	6.0	0.6	6.0	175	70	40	WASHDOWN MAS 25mm x CL40
32	45	6.5	0.6	6.0	224	90	40	WASHDOWN MAS 32mm x CL40
38	52	7.0	0.6	6.0	266	120	40	WASHDOWN MAS 38mm x CL40
51	65	7.0	0.6	6.0	357	150	40	WASHDOWN MAS 51mm x CL40

RECOMMENDED FOR

Premium hot water and open steam system washdown hose for the food and dairy industry. Used for paper mill, food handling or processing plant washdown service requiring a hose with a non-marking cover.

TUBE

EPDM based rubber, white, smooth.

REINFORCEMENT

High tensile textile cords.

COVER

EPDM based rubber, blue.

TEMPERATURE RANGE

-30°C to +164°C.

BURST PRESSURE

> 60 bar.

STANDARDS

FDA, animal derived ingredient free.









BRANDING TRANSFER LABEL

PREMIUM™ WASHDOWN MASTER - FDA 6 BAR – STEAM OPEN SYSTEM

INDUSTRIAL HOSE FOOD & BEVERAGE

PREMIUM™ MILK MASTER SD



								
mm	mm	mm	MPa	MPa	mm	kg/100m	m	REF.
38	48	5.0	0.6	1.8	190	100	40	MILK MAS SD 38mm x CL40
40	50	5.0	0.6	1.8	200	100	40	MILK MAS SD 40mm x CL40
45	55	5.0	0.6	1.8	225	110	40	MILK MAS SD 45mm x CL40
51	62	5.5	0.6	1.8	255	150	40	MILK MAS SD 51mm x CL40
63	75	6.0	0.6	1.8	315	190	40	MILK MAS SD 63mm x CL40
70	82	6.0	0.6	1.8	350	230	40	MILK MAS SD 70mm x CL40
76	90	7.0	0.6	1.8	380	290	40	MILK MAS SD 76mm x CL40
102	118	8.0	0.6	1.8	510	420	40	MILK MAS SD 102mm x CL40

** Vacuum resistance up to -0.9 bar









RECOMMENDED FOR	Premium hose construction for filling and discharge in milk tanker applications.
TUBE	NR based white food quality rubber.
REINFORCEMENT	Synthetic, high tensile textile, 2 steel wire helix.
COVER	NR based rubber, blue.
TEMPERATURE RANGE	-30°C to +70°C, intermittent up to +120°C / 20 minutes for cleaning.
BURST PRESSURE	> 18 bar.
STANDARDS	FDA, animal derived ingredient free.
BRANDING TRANSFER LABEL	PREMIUM™ MILK MASTER SD - FOOD 6 BAR

INDUSTRIAL HOSE FOOD & BEVERAGE

THE WORLD OF HOSE

PREMIUM™ BEVERAGE MASTER D



								
mm	mm	mm	MPa	MPa	kg/100m	m	REF.	
13	21	4.0	1.6	4.8	91	30	40	BEVERAGE MAS D 13mm x CL40
19	29	5.0	1.6	4.8	133	50	40	BEVERAGE MAS D 19mm x CL40
25	37	6.0	1.6	4.8	175	70	40	BEVERAGE MAS D 25mm x CL40
32	44	6.0	1.6	4.8	224	90	40	BEVERAGE MAS D 32mm x CL40
38	51	6.5	1.6	4.8	266	110	40	BEVERAGE MAS D 38mm x CL40
40	53	6.5	1.6	4.8	280	120	40	BEVERAGE MAS D 40mm x CL40
51	65	7.0	1.6	4.8	357	160	40	BEVERAGE MAS D 51mm x CL40
63	77	7.0	1.6	4.8	441	190	40	BEVERAGE MAS D 63mm x CL40
76	92	8.0	1.6	4.8	532	260	40	BEVERAGE MAS D 76mm x CL40
80	96	8.0	1.6	4.8	560	280	40	BEVERAGE MAS D 80mm x CL40
102	118	8.0	1.6	4.8	714	330	40	BEVERAGE MAS D 102mm x CL40

RECOMMENDED FOR

Premium pressure hose (D) for beer, ale, wines, alcohols (95%) and alcoholic beverages or liquid food. Transfer of milk, juice, soft drinks, pharmaceuticals, cosmetics or water-based products requiring an FDA sanitary hose.

TUBE

EPDM based white food quality rubber, oil and fat resistant (max.40%), odor- and tasteless.

REINFORCEMENT

Synthetic, high tensile textile.

COVER

EPDM red, ozone and chemicals resistant with cloth impression.

TEMPERATURE RANGE

-30°C to +90°C intermittent up to +130°C / 30 minutes for cleaning.

BURST PRESSURE

> 30 bar.

STANDARDS

FDA, animal derived ingredient free.

BRANDING TRANSFER LABEL









PREMIUM™ BEVERAGE MASTER D - BEER & WINE 16 BAR

INDUSTRIAL HOSE

WATER & AIR // MULTIPURPOSE

ESSENTIAL™ WATER MASTER D



								REF.
mm	mm	mm	MPa	MPa	kg/100m	m		
25	35	5.0	1.0	3.0	175	60		WATER MAS D 25mm x CL40
25	35	5.0	1.0	3.0	175	60	61*	WATER MAS D 25mm x CL61
32	42	5.0	1.0	3.0	224	70		WATER MAS D 32mm x CL40
32	42	5.0	1.0	3.0	224	70	61*	WATER MAS D 32mm x CL61
38	48	5.0	1.0	3.0	266	90		WATER MAS D 38mm x CL40
51	63	6.0	1.0	3.0	357	140		WATER MAS D 51mm x CL40
51	63	6.0	1.0	3.0	357	140	61*	WATER MAS D 51mm x CL61
63	76	6.5	1.0	3.0	441	180		WATER MAS D 63mm x CL40
63	76	6.5	1.0	3.0	441	180	61*	WATER MAS D 63mm x CL61
76	89	6.5	1.0	3.0	532	220		WATER MAS D 76mm x CL40
102	116	7.0	1.0	3.0	714	300		WATER MAS D 102mm x CL40
102	116	7.0	1.0	3.0	714	300	61*	WATER MAS D 102mm x CL61
127	142	7.5	1.0	3.0	889	400		WATER MAS D 127mm x CL40
152	169	8.5	1.0	3.0	1064	550		WATER MAS D 152mm x CL40
203	224	10.5	1.0	3.0	1421	950		WATER MAS D 203mm x CL40

* 61 m coils are made to order

RECOMMENDED FOR

Pressure hose (D) for water, waste water, sea water, mud, slurry. Water discharge in heavy duty service requiring a compact, rugged and lightweight hose.

TUBE

Black EPDM, smooth.

REINFORCEMENT

Synthetic, high tensile textile cord.

COVER

EPDM rubber, black, good weather and aging resistance.

TEMPERATURE RANGE

-35°C to +95°C.

BURST PRESSURE

> 30 bar.

BRANDING TRANSFER LABEL

ESSENTIAL™ WATER MASTER D - 10 BAR









INDUSTRIAL HOSE

WATER & AIR // MULTIPURPOSE

THE WORLD OF HOSE

ESSENTIAL™ WATER MASTER SD



								
mm	mm	mm	MPa	MPa	mm	kg/100m	m	REF.
25	35	5.0	1.0	3.0	125	70	40	WATER MAS SD 25mm x CL40
25	35	5.0	1.0	3.0	125	70	61*	WATER MAS SD 25mm x CL61
32	42	5.0	1.0	3.0	160	90	40	WATER MAS SD 32mm x CL40
32	42	5.0	1.0	3.0	160	90	61*	WATER MAS SD 32mm x CL61
38	48	5.0	1.0	3.0	190	110	40	WATER MAS SD 38mm x CL40
38	48	5.0	1.0	3.0	190	110	61*	WATER MAS SD 38mm x CL61
51	63	6.0	1.0	3.0	255	160	40	WATER MAS SD 51mm x CL40
51	63	6.0	1.0	3.0	255	160	61*	WATER MAS SD 51mm x CL61
63	76	6.5	1.0	3.0	315	230	40	WATER MAS SD 63mm x CL40
63	76	6.5	1.0	3.0	315	230	61*	WATER MAS SD 63mm x CL61
76	89	6.5	1.0	3.0	380	280	40	WATER MAS SD 76mm x CL40
76	89	6.5	1.0	3.0	380	280	61*	WATER MAS SD 76mm x CL61
102	116	7.0	1.0	3.0	510	390	40	WATER MAS SD 102mm x CL40
102	116	7.0	1.0	3.0	510	390	61*	WATER MAS SD 102mm x CL61
127	142	7.5	1.0	3.0	635	570	40	WATER MAS SD 127mm x CL40
152	169	8.5	1.0	3.0	760	800	40	WATER MAS SD 152mm x CL40
203	224	10.5	1.0	3.0	1015	1290	40	WATER MAS SD 203mm x CL40

* 61 m coils are made to order ** Vacuum resistance up to -0.9 bar

RECOMMENDED FOR

Vacuum and pressure hose (SD) for water, waste water, sea water, mud, slurry. Water suction in heavy duty service requiring a compact, rugged and light weight hose.

TUBE

Black EPDM, smooth.

REINFORCEMENT

Synthetic, high tensile textile with steel wire helix.

COVER

EPDM rubber, black, good weather and aging resistance.

TEMPERATURE RANGE

-35°C to +95°C.

BURST PRESSURE

> 30 bar.

BRANDING TRANSFER LABEL

ESSENTIAL™ WATER MASTER SD - 10 BAR

INDUSTRIAL HOSE

WATER & AIR // MULTIPURPOSE

GP80 PLUS



mm	mm	MPa	MPa	mm	mm/Hg	kg/100m	REF.
6	13.0	3.7	11.0	35	760	13	GP80+ - 6mm
8	15.0	3.7	11.0	50	760	16	GP80+ - 8mm
10	17.0	3.7	11.0	60	760	20	GP80+ - 10mm
13	20.5	3.7	11.0	70	635	26	GP80+ - 13mm
16	24.2	3.0	9.0	90	500	33	GP80+ - 16mm
19	29.0	3.0	9.0	110	500	47	GP80+ - 19mm
25	35.6	3.0	9.0	130	500	61	GP80+ - 25mm
32	42.8	3.0	9.0	200	250	75	GP80+ - 32mm
38	51.0	3.0	9.0	300	250	101	GP80+ - 38mm
51	64.0	3.0	9.0	500	125	144	GP80+ - 50mm

RECOMMENDED FOR

General industrial applications such as oil, alcohols, aqueous solutions, hydraulic fluids, acids, detergents and chemicals.
Static conductive for more security.

TUBE

NBR (Nitrile) based.

REINFORCEMENT

One or two fibre braids.

COVER

NBR/PVC based.

TEMPERATURE RANGE

-40°C to +100°C.

STANDARDS

Gates proprietary.

COUPLINGS

-4 to -20: MegaCrimp®; -24 to -32: GlobalSpiral Plus.

INDUSTRIAL HOSE

WATER & AIR // MULTIPURPOSE

THE WORLD OF HOSE

LOCK-ON PLUS

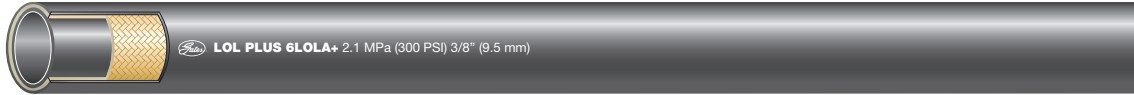

mm	"	mm	MPa	MPa	mm	mm/Hg	kg/100m	REF.
6	1/4	11.9	2.1	8.4	45	710	13	LOLA+04
10	3/8	15.9	2.1	8.4	75	710	16	LOLA+06
13	1/2	19.6	2.1	8.4	80	710	23	LOLA+08
16	5/8	23.9	2.1	8.4	115	710	30	LOLA+10
19	3/4	26.9	2.1	8.4	135	380	36	LOLA+12
6	1/4	11.9	2.1	8.4	45	710	13	LOLB+04
10	3/8	15.9	2.1	8.4	75	710	16	LOLB+06
13	1/2	19.6	2.1	8.4	80	710	23	LOLB+08
16	5/8	23.9	2.1	8.4	115	710	30	LOLB+10
19	3/4	26.9	2.1	8.4	135	380	36	LOLB+12
6	1/4	11.9	2.1	8.4	45	710	13	LOLC+04
10	3/8	15.9	2.1	8.4	75	710	16	LOLC+06
13	1/2	19.6	2.1	8.4	80	710	23	LOLC+08
16	5/8	23.9	2.1	8.4	115	710	30	LOLC+10
19	3/4	26.9	2.1	8.4	135	380	36	LOLC+12
6	1/4	11.9	2.1	8.4	45	710	13	LOLG+04
10	3/8	15.9	2.1	8.4	75	710	16	LOLG+06
13	1/2	19.6	2.1	8.4	80	710	23	LOLG+08
16	5/8	23.9	2.1	8.4	115	710	30	LOLG+10
19	3/4	26.9	2.1	8.4	135	380	36	LOLG+12
6	1/4	11.9	2.1	8.4	45	710	13	LOLR+04
10	3/8	15.9	2.1	8.4	75	710	16	LOLR+06
13	1/2	19.6	2.1	8.4	80	710	23	LOLR+08
16	5/8	23.9	2.1	8.4	115	710	30	LOLR+10
19	3/4	26.9	2.1	8.4	135	380	36	LOLR+12

INDUSTRIAL HOSE WATER & AIR // MULTIPURPOSE

LOCK-ON PLUS

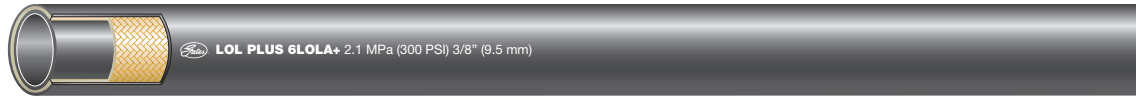

RECOMMENDED FOR	Petroleum-based hydraulic oils, antifreeze solutions, water, hot lubricating oils and air. Suitable for low-pressure cleaning and pneumatic systems, return lines and low pressure lines. Lock-On hose and couplings are not recommended for pressure surge applications or critical applications.
TUBE	NBR (Nitrile) based.
REINFORCEMENT	One fibre braid.
COVER	NBR/PVC based.
TEMPERATURE RANGE	-40°C to +100°C constant and +121°C intermittent. For water emulsions, etc. see Temperature Limits Table.
STANDARDS	Gates proprietary.
COUPLINGS	Lock-On Plus reusable couplings.
CHARACTERISTICS/BENEFITS	Available in 5 colours for easy colour coding. Easy to assemble.

A = black
R = red
B = blue
C = grey
G = green







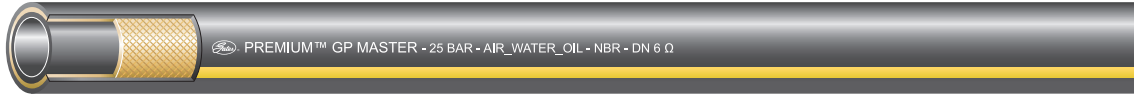

INDUSTRIAL HOSE

WATER & AIR // MULTIPURPOSE

THE WORLD OF HOSE

PREMIUM™ GP MASTER



								
mm	mm	mm	MPa	MPa	mm	kg/100m	m	REF.
6	14	4.0	2.5	8.0	50	17	60	GP MAS 6mm x CL60
8	16	4.0	2.5	8.0	50	21	60	GP MAS 8mm x CL60
10	18	4.0	2.5	8.0	75	24	60	GP MAS 10mm x CL60
13	21	4.0	2.5	8.0	100	30	60	GP MAS 13mm x CL60
16	25	4.5	2.5	8.0	125	40	60	GP MAS 16mm x CL60
19	29	5.0	2.5	8.0	125	54	60	GP MAS 19mm x CL60
25	37	6.0	2.5	8.0	200	83	60	GP MAS 25mm x CL60

RECOMMENDED FOR

Applications requiring a premium grade spiralled hose with excellent flexibility and maximum resistance to compressor air, water, gasoline, fuel oil and lubricant oils. Suitable for 20% biodiesel blends.

TUBE

Black NBR, smooth, conductive.

REINFORCEMENT

Textile layers, spiralled.

COVER

CR rubber, smooth cover, excellent resistance to weather and abrasion, good chemical and oil resistance, 1 extruded yellow longitudinal stripe.

TEMPERATURE RANGE

-40°C to +95°C.

BURST PRESSURE

> 3.15 x WP.

ELECTRICALLY CONDUCTIVE

R < 10⁶ Ohm.

INKJET LABEL

PREMIUM™ GP MASTER - 25 BAR - AIR_WATER_OIL NBR - DN .. Ø

INDUSTRIAL HOSE

WATER & AIR // MULTIPURPOSE

GP60



mm	mm	MPa	MPa	mm	mm/Hg	kg/100m	REF.
6	13.0	2.0	6.0	45	760	13	GP60 - 6mm
8	15.0	2.0	6.0	65	760	16	GP60 - 8mm
10	17.0	2.0	6.0	75	760	20	GP60 - 10mm
13	20.5	2.0	6.0	100	635	26	GP60 - 13mm
16	24.2	2.0	6.0	115	500	33	GP60 - 16mm
19	29.0	2.0	6.0	135	500	47	GP60 - 19mm
25	35.6	2.0	6.0	165	500	61	GP60 - 25mm

RECOMMENDED FOR	Hot water washdown applications up to +100°C, general industrial applications such as oil and hydraulic fluids (+100°C), alcohols and aqueous solutions.
TUBE	NBR (Nitrile) based.
REINFORCEMENT	One fibre braid.
COVER	NBR/PVC based.
TEMPERATURE RANGE	-40°C to +100°C.
STANDARDS	Gates proprietary.
COUPLINGS	MegaCrimp®.









INDUSTRIAL HOSE

WATER & AIR // MULTIPURPOSE

THE WORLD OF HOSE

PREMIUM™ MULTI MASTER



								
mm	mm	mm	MPa	MPa	mm	kg/100m	m	REF.
6	13	3.5	2.0	8.0	50	14	100	MULTI MAS 6mm x CL100
8	15	3.5	2.0	8.0	50	18	100	MULTI MAS 8mm x CL100
10	17	3.5	2.0	8.0	75	21	100	MULTI MAS 10mm x CL100
13	21	4.0	2.0	8.0	100	29	100	MULTI MAS 13mm x CL100
16	25	4.5	2.0	8.0	125	40	50	MULTI MAS 16mm x CL50
19	29	5.0	2.0	8.0	125	53	50	MULTI MAS 19mm x CL50
25	37	6.0	2.0	8.0	200	83	50	MULTI MAS 25mm x CL50
32	44	6.0	2.0	7.0	250	99	30	MULTI MAS 32mm x CL30
38	50	6.0	2.0	7.0	300	115	30	MULTI MAS 38mm x CL30

RECOMMENDED FOR

Premium multi-purpose hose for air and water applications requiring maximum flexibility in any industry, including mining, construction, agriculture, vehicle repair and in-plant operations. Outstanding resistance to heat and ozone. Suitable for light agricultural spraying, such as diluted solutions of herbicides.

TUBE

Black EPDM, smooth.

REINFORCEMENT

Textile layers, spiralled.

COVER

EPDM rubber, smooth with 1 blue extruded longitudinal stripe.

TEMPERATURE RANGE

-40°C to +100°C.

BURST PRESSURE

4 x WP.

ELECTRICALLY CONDUCTIVE

$R < 10^6 \text{ Ohm}$.

INKJET LABEL

PREMIUM™ MULTI MASTER - 20 BAR - AIR_WATER - EPDM - DN.. Ω

INDUSTRIAL HOSE

WATER & AIR // MULTIPURPOSE

PLANT MASTER™ XTREME™ 250 FORMERLY PREMO FLEX™



mm	"	mm	MPa	MPa	mm	mm/Hg	kg/100m	REF.
6	1/4	12.7	1.7	5.2	50	760	13	PLANT MAS XTRM 250 1/4"
10	3/8	16.8	1.7	5.2	75	760	20	PLANT MAS XTRM 250 3/8"
13	1/2	21.6	1.7	5.2	100	635	33	PLANT MAS XTRM 250 1/2"
16	5/8	24.9	1.7	5.2	130	510	39	PLANT MAS XTRM 250 5/8"
19	3/4	29.2	1.7	5.2	130	510	52	PLANT MAS XTRM 250 3/4"
25	1	37.3	1.7	5.2	200	250	82	PLANT MAS XTRM 250 1"
32	1.1/4	44.5	1.7	5.2	250	250	98	PLANT MAS XTRM 250 1.1/4"
38	1.1/2	50.8	1.7	5.2	300	250	115	PLANT MAS XTRM 250 1.1/2"

RECOMMENDED FOR	Applications requiring a premium grade spiral hose with excellent flexibility and maximum resistance to air, water, petroleum oils and lubricating oils (up to +100°C). Recommended for gasoline, kerosene and fuel oil transfer only (up to +48°C). Excellent weather and ozone resistance.
TUBE	NBR (Nitrile) based, black.
REINFORCEMENT	Synthetic, high tensile cord.
COVER	Modified nitrile, red.
TEMPERATURE RANGE	-40°C to +100°C.
STANDARDS	Gates proprietary.
CHARACTERISTICS/BENEFITS	Non-conductive at 1000 volts DC. Meets electrical resistance of one Megaohm per inch when subjected to 1000 volts DC. Storage and use may adversely affect electrical properties.
BRANDING	GATES® PLANT MASTER™ XTREME™ 250 MULTI-PURPOSE 3/8 INCH (9.5MM) 250 PSI (1.72MPa) WP NON-CONDUCTIVE AT 1000V DC (>1 MEGOHM/IN.) MADE IN USA

INDUSTRIAL HOSE

WATER & AIR // MULTIPURPOSE

THE WORLD OF HOSE

PLANT MASTER® 200 / 250 BLACK FORMERLY ADAPTA FLEX™ BLACK



mm	"	mm	MPa	MPa	mm	mm/Hg	kg/100m	REF.
6	1/4	12.7	1.4	4.1	76	762	13	PLANT MAS 200 BLACK 1/4"
10	3/8	16.8	1.4	4.1	76	762	20	PLANT MAS 200 BLACK 3/8"
13	1/2	20.6	1.4	4.1	127	635	30	PLANT MAS 200 BLACK 1/2"
16	5/8	24.6	1.4	4.1	152	508	39	PLANT MAS 200 BLACK 5/8"
19	3/4	28.2	1.4	4.1	152	381	46	PLANT MAS 200 BLACK 3/4"
25	1	35.6	1.4	4.1	203	254	72	PLANT MAS 200 BLACK 1"
32	1.1/4	43.9	1.7	5.1	254	254	101	PLANT MAS 250 BLACK 1.1/4"
38	1.1/2	50.3	1.7	5.1	305	254	126	PLANT MAS 250 BLACK 1.1/2"

RECOMMENDED FOR

Air and water applications requiring maximum flexibility in any industry, including mining, construction, agriculture, vehicle repair and in-plant operations. Outstanding resistance to heat and ozone. Suitable for light agricultural spraying, such as dilute solutions of herbicides.

TUBE

Type P (EPDM), black.

REINFORCEMENT

Synthetic, high tensile textile cord.

COVER

Type P (EPDM). Black. All sizes through 1/2" are perforated.

TEMPERATURE RANGE

-40°C to +93°C continuous service.

STANDARDS

Gates proprietary.

BRANDING

GATES® PLANT MASTER™ 200 1/4 INCH [6.3MM] 200 PSI [13.8 BAR]
MADE IN USA

INDUSTRIAL HOSE

WATER & AIR // MULTIPURPOSE

GP40



mm	mm	MPa	MPa	mm	mm/Hg	kg/100m	REF.
6	12.0	1.3	4.0	45	760	11	GP40 - 6mm
8	15.0	1.3	4.0	65	760	16	GP40 - 8mm
10	17.0	1.3	4.0	75	760	19	GP40 - 10mm
13	20.5	1.3	4.0	90	635	25	GP40 - 13mm
16	24.0	1.3	4.0	115	500	31	GP40 - 16mm
19	28.0	1.3	4.0	135	500	46	GP40 - 19mm
25	35.0	1.3	4.0	180	250	61	GP40 - 25mm
32	44.0	1.3	4.0	200	250	93	GP40 - 32mm
38	51.0	1.3	4.0	300	250	120	GP40 - 38mm

RECOMMENDED FOR

General air service up to +80°C and general water service up to +100°C and applications requiring maximum flexibility and high abrasion resistance. Resistant to ozone and weather influences.

TUBE

EPDM based.

REINFORCEMENT

One or two textile layers.

COVER

EPDM based.

TEMPERATURE RANGE

-40°C to +100°C constant and +121°C intermittent.

STANDARDS

Gates proprietary.

COUPLINGS

-4 to -20: MegaCrimp®; -24: GlobalSpiral Plus.









INDUSTRIAL HOSE

WATER & AIR // MULTIPURPOSE

THE WORLD OF HOSE

AIR MASTER™ DIVING UMBILICAL FORMERLY 33HB DIVERS' AIR











								
mm	mm	mm	MPa	MPa	mm	kg/100m	m	REF.
10	19	4.8	7.8	31.0	102	30	182.9-213.1	AIR MASTER DIVING UMBILICAL 1000 3/8"
10	19	4.8	7.8	31.0	102	30	304.8-Plus m	AIR MASTER DIVING UMBILICAL 1000 3/8"
13	24	5.6	6.9	27.6	127	40	15.24-91.14	AIR MASTER DIVING UMBILICAL 1125 1/2"
13	24	5.6	6.9	27.6	127	40	304.8-Plus m	AIR MASTER DIVING UMBILICAL 1125 1/2"

RECOMMENDED FOR	Handling mixtures of oxygen, helium and nitrogen gases customarily used in diving applications as air breathing hose. The kink resistance hose is designed for extra long wear under normal operating use.
TUBE	Type C (Nitrile), black.
REINFORCEMENT	Braided, high tensile synthetic textile cord.
COVER	Type A (Neoprene), black. All sizes are perforated.
TEMPERATURE RANGE	-40°C to +49°C continuous service.
STANDARDS	Meets MIL-H-2815G Section 3.12.2 off-gassing for air breathing applications, especially diving.
BRANDING TRANSFER LABEL	GATES® AIR MASTER™ DIVING UMBILICAL (1000-1125) 3/8 INCH (9.5MM) MADE IN U.S.A

INDUSTRIAL HOSE MATERIAL HANDLING

ESSENTIAL™ SANDBLAST MASTER D



								
mm	mm	mm	MPa	MPa	kg/100m	m	REF.	
19	34	7.5	1.2	4.8	133	80	40	SANDBLAST MAS D 19mm x CL40
25	40	7.5	1.2	4.8	175	100	40	SANDBLAST MAS D 25mm x CL40
32	48	8.0	1.2	4.8	224	120	40	SANDBLAST MAS D 32mm x CL40
38	56	9.0	1.2	4.8	266	150	40	SANDBLAST MAS D 38mm x CL40









RECOMMENDED FOR	Hose for sandblasting of metal castings, steel, stone, sand and cement wherever abrasive materials are carried at a high velocity.
TUBE	NR/BR based, black, anti-static.
REINFORCEMENT	High tensile synthetic textile cord.
COVER	NR/BR based, anti-static, resistant to weather and abrasion.
TEMPERATURE RANGE	-40°C to +75°C.
BURST PRESSURE	> 48 bar.
ELECTRICALLY CONDUCTIVE	R < 10 ⁶ Ohm.
STANDARDS	DIN 53516: ~55 mm ³ .
BRANDING TRANSFER LABEL	ESSENTIAL™ SANDBLAST MASTER D - 12 BAR

INDUSTRIAL HOSE MATERIAL HANDLING

THE WORLD OF HOSE

ESSENTIAL™ CEMENT MASTER D











								
mm	mm	mm	MPa	MPa	kg/100m	m		REF.
51	65	7.0	0.8	2.4	357	160	40	CEMENT MAS D 51mm x CL40
63	79	8.0	0.8	2.4	441	220	40	CEMENT MAS D 63mm x CL40
76	94	9.0	0.8	2.4	532	290	40	CEMENT MAS D 76mm x CL40
80	98	9.0	0.8	2.4	560	310	40	CEMENT MAS D 80mm x CL40
90	110	10.0	0.8	2.4	630	380	40	CEMENT MAS D 90mm x CL40
102	122	10.0	0.8	2.4	714	410	40	CEMENT MAS D 102mm x CL40
110	130	10.0	0.8	2.4	770	440	40	CEMENT MAS D 110mm x CL40

RECOMMENDED FOR	Pressure hose (D) for pneumatic transport of dry cement, slurries, dust, limestone, wood chips, coal, sand, gravel, ground slate, asphalt roofing chips, metal shavings. Contains a static-conducting black rubber in the tube and a ground wire in the hose wall for static charge dissipation.
TUBE	Black, anti-static NR/BR based rubber.
REINFORCEMENT	High tensile synthetic textile cord, static wire.
COVER	Black, anti-static NR/SBR based rubber, resistant to weather and abrasion.
TEMPERATURE RANGE	-20°C to +80°C.
BURST PRESSURE	> 24 bar.
ELECTRICALLY CONDUCTIVE	$R < 10^6 \text{ Ohm}$.
STANDARDS	DIN 53516.
BRANDING TRANSFER LABEL	ESSENTIAL™ CEMENT MASTER D - 8 BAR

INDUSTRIAL HOSE MATERIAL HANDLING

ESSENTIAL™ CEMENT MASTER SD



								
mm	mm	mm	MPa	MPa	mm	kg/100m	m	REF.
51	67	8.0	0.8	2.4	255	220	40	CEMENT MAS SD 51mm x CL40
63	81	9.0	0.8	2.4	315	300	40	CEMENT MAS SD 63mm x CL40
76	96	10.0	0.8	2.4	380	400	40	CEMENT MAS SD 76mm x CL40
80	100	10.0	0.8	2.4	400	420	40	CEMENT MAS SD 80mm x CL40
90	110	10.0	0.8	2.4	450	460	40	CEMENT MAS SD 90mm x CL40
102	122	10.0	0.8	2.4	510	530	40	CEMENT MAS SD 102mm x CL40
110	132	11.0	0.8	2.4	550	650	40	CEMENT MAS SD 110mm x CL40
127	149	11.0	0.8	2.4	635	800	40	CEMENT MAS SD 127mm x CL40
152	175	11.5	0.8	2.4	760	970	40	CEMENT MAS SD 152mm x CL40
203	228	12.5	0.8	2.4	1015	1480	40	CEMENT MAS SD 203mm x CL40

** Vacuum resistance up to -0.9 bar

RECOMMENDED FOR

Vacuum and pressure hose (SD) for pneumatic transport of dry cement, slurries, dust, limestone, wood chips, coal, sand, gravel, ground slate, asphalt roofing chips, metal shavings. Contains a static-conducting black rubber in the tube and a ground wire in the hose wall for static charge dissipation.

TUBE

Black, anti-static NR/BR based rubber.

REINFORCEMENT

High tensile synthetic textile cord, steel wire helix, static wires.

COVER

Black, anti-static NR/SBR based rubber, resistant to weather and abrasion.

TEMPERATURE RANGE

-20°C to +80°C.

BURST PRESSURE

> 24 bar.

ELECTRICALLY CONDUCTIVE

$R < 10^6 \text{ Ohm}$.

STANDARDS

DIN 53516.

BRANDING TRANSFER LABEL

ESSENTIAL™ CEMENT MASTER SD - 8 BAR

INDUSTRIAL HOSE MATERIAL HANDLING

THE WORLD OF HOSE

ESSENTIAL™ SILO MASTER D - FOOD











mm	mm	mm	MPa	MPa	kg/100m	m	REF.
51	65	7.0	0.8	2.4	357	150	SILO MAS D - 51mm x CL40
63	81	9.0	0.8	2.4	441	240	SILO MAS D - 63mm x CL40
76	96	10.0	0.8	2.4	532	310	SILO MAS D - 76mm x CL40
80	100	10.0	0.8	2.4	560	330	SILO MAS D - 80mm x CL40
90	110	10.0	0.8	2.4	630	370	SILO MAS D - 90mm x CL40
102	122	10.0	0.8	2.4	714	390	SILO MAS D - 102mm x CL40
110	132	11.0	0.8	2.4	770	450	SILO MAS D - 110mm x CL40

RECOMMENDED FOR	Pressure hose (D) for pneumatic transport of abrasive bulk food materials such as plastic granules, grain and sugar.
TUBE	White, NR/BR based rubber.
REINFORCEMENT	High tensile synthetic textile cord, static wire.
COVER	Black, anti-static NR/BR based rubber, resistant to weather and abrasion.
TEMPERATURE RANGE	-20°C to +80°C.
BURST PRESSURE	> 24 bar.
STANDARDS	FDA.
BRANDING TRANSFER LABEL	ESSENTIAL™ SILO MASTER D - FOOD 8 BAR

INDUSTRIAL HOSE MATERIAL HANDLING

ESSENTIAL™ SILO MASTER SD - FOOD



								
mm	mm	mm	MPa	MPa	mm	kg/100m	m	REF.
51	67	8.0	0.8	2.4	204	210	40	SILO MAS SD - 51mm x CL40
63	81	9.0	0.8	2.4	252	280	40	SILO MAS SD - 63mm x CL40
76	96	10.0	0.8	2.4	304	370	40	SILO MAS SD - 76mm x CL40
80	100	10.0	0.8	2.4	320	380	40	SILO MAS SD - 80mm x CL40
90	110	10.0	0.8	2.4	360	430	40	SILO MAS SD - 90mm x CL40
102	122	10.0	0.8	2.4	408	520	40	SILO MAS SD - 102mm x CL40
110	132	11.0	0.8	2.4	440	620	40	SILO MAS SD - 110mm x CL40
152	175	11.5	0.8	2.4	608	960	40	SILO MAS SD - 152mm x CL40
203	228	12.5	0.8	2.4	812	1400	40	SILO MAS SD - 203mm x CL40

** Vacuum resistance up to -0.9 bar









RECOMMENDED FOR	Vacuum and pressure hose (SD) for pneumatic transport of abrasive bulk food materials such as plastic granules, grain and sugar.
TUBE	White, NR/BR based rubber.
REINFORCEMENT	High tensile synthetic textile cord, steel wire helix, static wire.
COVER	Black, NR/BR based rubber, resistant to weather and abrasion.
TEMPERATURE RANGE	-20°C to +80°C.
BURST PRESSURE	> 24 bar.
STANDARDS	FDA.
BRANDING TRANSFER LABEL	ESSENTIAL™ SILO MASTER SD - FOOD 8 BAR

INDUSTRIAL HOSE MATERIAL HANDLING

THE WORLD OF HOSE

ESSENTIAL™ CONCRETE MASTER D



							
mm	mm	mm	MPa	MPa	kg/100m	m	REF.
19	31	6.0	4.0	12.0	50	40	CONCRETE MAS D 19mm x CL40
25	39	7.0	4.0	12.0	175	40	CONCRETE MAS D 25mm x CL40
32	47	7.5	4.0	12.0	224	40	CONCRETE MAS D 32mm x CL40
35	50	7.5	4.0	12.0	245	40	CONCRETE MAS D 35mm x CL40
38	54	8.0	4.0	12.0	266	40	CONCRETE MAS D 38mm x CL40
50	68	9.0	4.0	12.0	350	40	CONCRETE MAS D 50mm x CL40
63	83	10.0	4.0	12.0	441	40	CONCRETE MAS D 63mm x CL40

RECOMMENDED FOR	Concrete pump hose for abrasive substances such as concrete mortar, cement, plaster, grout and cement applications, handling a multitude of materials being pumped to concrete structures, tunnel faces, swimming pools.
TUBE	Black, anti-static NR/BR/SBR based rubber.
REINFORCEMENT	High tensile synthetic textile cord.
COVER	Black, anti-static NR/SBR based rubber, resistant to weather and abrasion.
TEMPERATURE RANGE	-20°C to +70°C.
BURST PRESSURE	> 120 bar.
ELECTRICALLY CONDUCTIVE	$R < 10^6 \text{ Ohm}$.
STANDARDS	DIN 53516: ~70 mm ³ .
BRANDING TRANSFER LABEL	ESSENTIAL™ CONCRETE MASTER D - 40 BAR



BLACK GOLD™

Hoses built to industry standards for tough duty in and around oil and gas fields, from the drilling rig to the frack truck.



Black Gold™ Rotary Vibrator 7,500

Flexible connection between standpipe and swivel, or pump and standpipe (7,500 psi): API 7K (Grade E).



Black Gold™ Rotary Vibrator 5,000

Flexible connection between standpipe and swivel, or pump and standpipe (5,000 psi): API 7K (Grade D).



Black Gold™ Slim Hole Rotary (1500-5000)

Flexible connector in pressure lines used to convey mud or air in rotary applications (1,500 – 5,000 psi).



Black Gold™ XTreme™ Choke & Kill 10,000

API Spec 16C certified hose used on drilling rig BOP systems (10,000 psi).



Black Gold™ Choke & Kill 15,000 / 10,000 / 5,000

Flexible hose used on drilling rig BOP systems (15,000 psi / 10,000 psi / 5,000 psi): API 7K.



Black Gold™ Rotary Vibrator 7,500 / 5,000 Sour Service

Engineered to withstand up to 20% H₂S (7,500 psi).



Black Gold™ Cementing 15,000 / 10,000 / 5,000

For conveying cement slurries at high pressure (15,000 psi / 10,000 psi / 5,000 psi).



Black Gold™ 5000 MegaShield

Fire resistant hose for use in high performance BOP systems API 16D.

INDUSTRIAL HOSE OILFIELD PRODUCTS

THE WORLD OF HOSE



Black Gold™ Blender Transfer 150 D

For transfer of fluids used in fracking and well stimulation.



Black Gold™ Decoking 7,500 / 5,000

For transferring coke from silos to railroad cars (7,500 psi / 5,000 psi).



Black Gold™ Fuel 300 SD

For fuel suction/discharge in offshore/onshore transfer applications.



Black Gold™ Fuel 300 D

For fuel discharge in offshore/ onshore transfer applications.



Black Gold™ Oilfield Service 400 SD

Suction/discharge hose for a wide range of oilfield fluid transfer applications.



Black Gold™ Oilfield Service 400 D

Discharge hose for a wide range of oilfield fluid transfer applications. Also available in MegaTuff™ and UltraBration™ covers.

To find out more about our rotary hose offering please go to our website
[gates.com/industries/industrial/oilfield](https://www.gates.com/industries/industrial/oilfield).



INDUSTRIAL HOSE OILFIELD PRODUCTS



LARGE DIAMETER MEGASPIRAL™ HOSE ASSEMBLIES

Today's more powerful large-capacity industrial equipment needs hydraulic hose assemblies that are engineered for their extreme requirements – high pressures, unexpected surges and dramatic flexing. With internal diameters up to size -48, one MegaSys® MegaSpiral™ hose assembly outperforms multi-line assemblies with fewer components, less routing, less abrasion, less expense, and less maintenance while providing more power to the system for improved efficiency and productivity. New MegaSpiral™ 40EFG5K and 48EFG4K assemblies are tested and performing over 1 million impulse cycles at 133% of working pressure at +121°C, far above the SAE J2545 reference standard.

↔		⊘	⊙	🌀	👤	📊	Recommended Couplings		
-size	DN	mm	MPa	MPa	mm	kg/100m	ISO 6164-4	Code 62	API-LP
-40	63	85.1	35.0	140.0	760	897	40GSM63FLSHCF	40GSM40FLHCFM	40GSM40API-LP
-48	76	98.0	28.0	112.0	890	1012	48GSM80FLSHCF	48GSM48FLHCFM	48GSM48API-LP

How to order

Black Gold™ oilfield and large bore MegaSpiral™ hose assemblies are produced in authorised and specialised Gates assembly centres with dedicated equipment to manipulate, cut, crimp, pack and certify these large bore assemblies. Please contact your Gates representative for further details and customised offer to your specific application needs.



Maximise flow rate
and power for large
capacity equipment

CHEMICAL RESISTANCE TABLE

THE WORLD OF HOSE

Chemical	Form (at room temperature unless otherwise stated)	Gates Hose / Polymers														Couplings / Adapters					
		Teflon®	XLPE	UHMWPE	EPDM	NBR	SBR	NR	CR	Butyl	Fluorocarbon	Hypalon®	CPE	Nylon	PVC	Iron/Carbon Steel	Stainless Steel 304	Stainless Steel 316	Aluminum	Brass	Polypro
		NOTE: Ratings are for the affect on the polymer only!																			
1 = Preferred - Constant Contact 2 = Acceptable - Intermittent Contact X = Not Recommended - = No Data																					
NOTE: Ratings are for the affect on the polymer only!																					
A																					
Absorption Oil	Liquid	1	2	2	X	1	X	X	2	X	1	2	1	1	-	-	-	-	-	1	-
Acetal	Colorless Liquid	1	1	1	1	-	-	-	-	1	X	-	1	-	-	-	-	-	-	1	-
Acetaldehyde	Colorless Liquid	1	1	1	1	X	2	2	X	1	X	X	1	2	X	1	1	1	1	1	1
Acetamide	Liquid above 176°F(80°C)	1	1	2	2	2	X	X	2	2	X	-	1	-	-	-	2	-	1	X	-
Acetic Acid (40% or less)	Clear Colorless Liquid	1	1	1	1	X	2	X	2	1	X	2	1	-	-	X	2	2	2	X	2
Acetic Acid (56% or less)	Clear Colorless Liquid	1	1	1	1	X	2	X	2	1	X	2	1	X	2	X	2	2	2	X	2
Acetic Acid (85% or less)	Clear Colorless Liquid	1	1	1	2	X	2	X	X	X	X	X	X	X	X	-	2	-	-	-	X
Acetic Acid (Glacial - 99.4%)	Clear Colorless Liquid	1	1	X	X	X	2	X	X	X	X	X	1	X	X	-	2	2	-	-	X
Acetic Acid, Anhydride	Clear Colorless Liquid	1	-	X	-	X	X	X	X	2	-	2	1	X	X	-	2	2	-	-	X
Acetic Anhydride (Acetic Oxide)	Colorless Liquid	1	1	1	1	X	X	X	-	2	X	2	1	X	X	X	2	2	2	X	X
Acetic Ether (Ethyl Acetate)	Colorless Liquid	1	1	1	2	X	X	X	X	2	X	X	2	1	X	1	1	1	1	1	2
Acetic Oxide (Acetic Anhydride)	Colorless Liquid	1	1	1	1	-	X	X	-	2	X	2	1	X	X	X	2	2	2	X	X
Acetone (Dimethylketone)	Colorless Liquid	1	1	X	2	X	X	X	X	2	X	X	1	1	X	1	1	1	1	1	2
Acetone Cyanohydrin	Colorless Liquid	1	1	2	2	-	X	X	-	2	-	-	2	-	-	-	-	-	-	-	-
Acetonitrile (Methyl Cyanide)	Colorless Liquid	1	1	2	X	X	2	2	2	2	2	-	2	1	-	1	-	-	-	-	-
Acetophenone	Colorless Liquid	1	2	2	1	X	X	X	X	1	X	-	-	-	-	-	-	-	-	-	2
Acetyl Chloride	Colorless Liquid	1	-	-	-	-	-	-	-	-	1	-	-	-	-	-	-	-	-	-	-
Acetyl Oxide (Acetic Anhydride)	Colorless Liquid	1	1	1	1	X	X	X	-	2	X	2	1	X	X	X	2	2	2	X	X
Acetyl-P-Toluidine (In Ether or Alcohols)	In Alcohol or Ether	1	1	1	1	-	X	X	-	2	X	-	1	-	-	-	-	-	-	-	-
Acetylene	Gas	NO HOSE AVAILABLE																			
Acetylene Dichloride (Dichloroethylene)	Colorless Liquid	1	X	X	X	-	X	X	-	X	1	-	X	1	X	-	-	-	-	-	X
Acetylene Tetrachloride (Tetrachloroethane)	Colorless Liquid	1	X	X	X	-	X	X	-	X	1	-	X	1	X	-	-	-	-	-	-
Acrolein (Hydroquinone Inhibited)	Colorless to Yellow Liquid	1	1	1	X	-	-	-	-	2	X	-	-	-	-	-	-	-	-	-	-
Acrylamide	Colorless Crystals	1	1	2	-	-	-	-	-	-	1	-	-	-	-	-	-	-	-	-	-
Acrylates (HEA or HPA)	Colorless Liquid	1	1	1	X	-	-	-	-	-	1	-	1	-	-	-	-	-	-	-	-
Acrylic Acid	Colorless Liquid	1	1	1	-	-	-	-	-	-	1	-	-	-	-	-	-	-	-	-	-
Acrylic Acid (Glacial 97%)	Colorless Liquid	1	1	1	X	X	X	X	X	X	1	X	X	X	X	-	-	-	-	-	-
Acrylic Emulsion	Liquid	1	1	1	X	-	-	-	-	-	1	-	-	-	-	-	-	-	-	-	-
Acrylonitrile	Colorless Liquid	1	2	2	X	X	2	2	X	X	X	X	1	-	1	1	1	1	-	-	-
Adipic Acid (70°F)	White Crystals	1	1	X	1	X	X	1	X	-	1	-	-	X	X	-	-	-	-	-	-
Aeroshell 7A, 17 Grease	Liquid	1	-	-	-	1	-	-	2	-	-	-	-	-	-	1	1	1	1	-	-
Air, 212°F (100°C)	Colorless Gas	1	1	2	1	1	2	X	1	1	1	1	1	X	2	1	1	1	1	1	-
Air, 257°F (125°C)	Colorless Gas	1	1	X	1	X	X	X	2	1	1	1	1	X	X	-	-	-	-	-	-
Air, 300°F (149°C)	Colorless Gas	1	1	X	1	X	X	X	X	1	1	X	X	X	X	-	-	-	-	-	-
Air, Ambient	Colorless Gas	1	1	1	1	1	1	1	1	1	1	1	1	1	1	1	1	1	1	1	1
Aircraft Hyd. Oil AA	Liquid	1	1	-	X	1	-	-	-	X	-	-	-	-	-	1	1	1	1	1	-
Alachlor (Lasso)	Colorless Crystals	1	1	-	-	-	-	1	-	-	-	-	-	-	-	-	1	1	-	-	-
Alkaline Liquid (NOS)	In Water Solutions	1	1	1	1	-	-	-	-	1	2	-	1	-	-	-	-	-	-	-	-
Alkyaryl Polyether Alcohol	-	1	1	1	-	-	-	-	-	-	1	-	1	-	-	-	-	-	-	-	-
Alkyd Resin (Thermosetting Polymer)	Varies	1	1	-	-	-	-	-	-	-	-	-	-	-	-	-	-	-	-	-	-
Alkyaryl Sulfonate (Alkylbenzene Sulfonate)	Powder	1	1	1	-	1	-	1	-	-	1	X	1	-	-	1	1	-	-	-	-
Allomalaic Acid (Fumaric Acid) Solution	Liquid	1	1	-	2	1	2	2	-	-	1	-	-	-	X	-	1	1	-	-	-
Allyl Alcohol	Colorless Liquid	1	1	1	1	1	-	1	1	1	1	1	1	X	X	-	-	-	-	-	-
Allyl Bromide	Colorless to Yellow Liquid	1	-	-	-	-	-	-	-	-	-	-	-	-	-	-	-	-	-	-	-
Allyl Chloride	Colorless Liquid	1	1	X	X	X	X	X	X	X	1	-	2	1	X	-	1	1	-	-	2
Alpha Methylstyrene	Colorless Liquid	1	2	2	X	X	X	X	X	X	1	-	X	1	X	-	-	-	-	-	-
Alpha Olefin Sulfonate	Powder	-	-	-	-	-	-	1	-	-	-	-	-	-	-	-	-	-	-	-	-
Alpha Picoline	Colorless Liquid	1	1	-	-	-	-	-	-	-	-	-	-	-	-	-	-	-	-	-	-
Alum (Aluminum Sulphate or Other)	White Crystals	1	1	-	1	1	-	1	1	-	-	-	-	-	-	X	X	2	X	X	1
Alum, Potash (Aluminum Potassium Sulfate)	White Crystals	1	-	-	-	-	-	1	-	-	-	-	-	-	-	X	2	2	X	X	1
Alumina - Calcined (Conveyed Pneumatically)	Granular	-	-	-	-	-	-	1	-	-	-	-	-	-	-	-	-	-	-	-	-

Chemical	Form (at room temperature unless otherwise stated)	Gates Hose / Polymers														Couplings / Adapters					
		Teflon®	XLPE	UHMWPE	EPDM	NBR	SBR	NR	CR	Butyl	Fluorocarbon	Hypalon®	CPE	Nylon	PVC	Iron/Carbon Steel	Stainless Steel 304	Stainless Steel 316	Aluminum	Brass	Polypro
		1 = Preferred - Constant Contact 2 = Acceptable - Intermittent Contact X = Not Recommended - = No Data NOTE: Ratings are for the affect on the polymer only!																			
Alumina Trihydrate (Conveyed Pneuamatically)	White Crystalline Powder	-	-	-	-	-	-	1	-	-	-	-	-	-	-	-	-	-	-	-	-
Aluminum Acetate	White Powder	1	1	-	-	-	1	1	-	-	-	-	-	-	-	-	-	1	1	-	X
Aluminum Alkyl (ie Triethylaluminum)	Colorless Liquid	X	X	X	X	X	X	X	X	X	1	X	X	X	X	-	-	-	-	-	-
Aluminum Bromide	White to Yellow Crystals	1	1	-	1	1	1	1	1	1	1	1	-	-	-	X	2	2	-	X	-
Aluminum Chloride Solution	White to Yellow Solution	1	1	X	1	1	1	1	-	1	1	-	1	-	-	X	2	2	X	X	1
Aluminum Chloride, Anhydrous	White to Yellow Crystals	-	-	-	-	-	-	1	-	-	-	-	-	-	-	-	-	-	-	-	
Aluminum Chlorohydrate Solution (Up to 50%)	White Solution	1	1	1	1	1	-	-	-	1	1	-	1	-	-	-	-	-	-	-	-
Aluminum Fluoride	White Crystals	1	1	-	-	-	-	1	1	-	-	-	-	-	1	X	2	2	2	X	1
Aluminum Formate (Di & Tri In Water)	In Hot Water	1	1	1	1	1	X	X	-	1	1	-	1	-	-	-	-	-	-	-	-
Aluminum Hydroxide (Alumina Trihydrate)	In Mineral Acid or Caustic Soda	1	1	1	-	X	X	X	1	1	1	-	1	X	X	-	1	1	-	1	1
Aluminum Nitrate	In Cold Water	1	1	1	1	1	1	1	1	1	1	1	1	-	1	X	1	1	2	-	1
Aluminum Phosphate Solution	In HCl or HNO3 (slightly soluble)	1	1	1	-	X	X	X	X	-	1	-	-	X	X	-	-	-	-	-	-
Aluminum Salts	Varies	1	1	-	1	1	1	1	1	1	-	1	-	-	1	-	2	2	2	-	1
Aluminum Sulfate	White Crystals	1	1	-	1	1	-	1	1	-	-	-	-	-	X	X	2	X	X	1	-
Aluminum Sulfate Solution	In Water	1	1	1	1	1	1	1	-	1	1	-	1	-	-	X	X	2	X	X	1
Aluminum Sulfate Solution (49.7% H2O)	Liquid	1	1	1	1	1	1	1	1	1	1	-	1	1	1	X	X	2	X	X	1
Amines (A class of Organic Compounds)	Varies	1	1	1	-	-	-	-	-	-	-	-	-	-	-	-	-	-	-	-	-
Amines (Aromatic - IE P-Toluidine)	White Plates (Solid)	1	-	-	-	-	-	1	-	-	-	-	-	-	-	-	-	-	-	-	-
Amines (Mixed)	Varies	1	2	-	2	2	2	2	2	2	X	-	-	-	-	1	-	X	X	-	-
Amines (Primary, Secondary, Tertiary, Etc)	Varies	1	2	-	-	-	-	-	-	-	X	-	-	-	-	-	-	-	-	-	-
Aminodiphenylamine	Purple Powder	1	2	-	-	-	-	-	-	-	-	-	-	-	-	-	-	-	-	-	-
Aminoethanol (Ethanolamine)	Colorless Viscous Liquid	1	2	1	2	2	2	2	2	2	X	X	1	1	2	1	1	1	-	1	-
Aminoethylethanolamine	Liquid	1	2	1	2	-	-	-	-	1	-	-	1	1	-	-	-	-	-	-	-
Ammonia (Anhydrous)	Gas or liquid	NO HOSE AVAILABLE																			
Ammonia (Aqueous up to 30% NH3)	Colorless Liquid	1	1	1	1	1	1	1	1	1	2	1	1	1	1	-	1	1	-	X	1
Ammonia Liquor	Colorless Liquid	1	-	1	-	-	-	-	-	-	-	-	-	-	-	-	-	-	-	-	-
Ammoniated Fatty Acid (ie Ammonium Caprylate)	Liquid above 167°F (75°C)	1	1	1	-	-	-	-	-	-	1	-	-	-	-	-	-	-	-	-	-
Ammonium Acetate	In Water	1	1	1	1	1	1	1	2	1	1	-	1	2	1	-	1	1	-	X	1
Ammonium Bicarbonate	White Crystals	1	-	-	-	-	-	1	-	-	-	-	-	-	1	-	-	-	-	-	1
Ammonium Bisulfate (50%)	Colorless Liquid	1	1	1	1	-	-	-	-	1	1	-	1	-	-	-	-	-	-	-	-
Ammonium Carbonate	Colorless to White Powder	1	1	-	-	X	-	1	2	-	-	-	-	-	1	1	1	1	-	-	1
Ammonium Chloride	White Crystals	1	-	X	-	-	-	1	-	-	-	-	-	-	-	-	2	2	-	X	1
Ammonium Chloride Solution	Liquid	1	1	-	1	2	1	1	X	1	-	1	1	X	1	-	2	2	-	X	1
Ammonium Flouride	White Crystals	-	-	-	-	-	-	1	-	-	-	-	-	-	-	-	-	-	-	-	-
Ammonium Hydroxide (16%, 20%, 26%, & 30%)	Colorless Liquid	1	1	1	-	-	-	-	-	-	2	-	-	-	-	2	1	1	-	X	1
Ammonium Hydroxide (up to 30% NH3)	Colorless Liquid	1	1	1	1	2	X	2	2	2	2	1	1	X	X	2	1	1	-	X	1
Ammonium Metaphosphate	White powder	1	1	-	1	2	2	2	2	1	-	2	-	-	2	1	1	1	X	-	1
Ammonium Nitrate	Colorless Crystals	1	1	-	-	-	-	1	-	-	-	-	-	-	-	1	1	1	2	X	1
Ammonium Nitrate Fertilizer (20.5% N or 33.5% N)	Aggregate	1	-	-	-	-	-	1	-	-	-	-	-	-	-	1	1	1	2	X	1
Ammonium Nitrate Prills and Oil	Aggregate	1	-	-	-	1	-	1	-	-	-	-	-	-	-	1	1	1	2	X	1
Ammonium Nitrate Solution (up to 83%)	Liquid	1	1	1	1	1	-	1	1	-	1	1	1	-	1	1	1	2	X	1	-
Ammonium Nitrite	Colorless crystal	1	1	-	-	X	X	X	2	-	-	-	1	-	-	-	1	1	-	-	1
Ammonium Persulfate	Solution in Water	1	1	-	-	X	-	X	-	X	-	-	-	-	-	-	1	1	-	X	X
Ammonium Phosphate	White Crystals or Powder	1	-	-	-	-	-	1	-	-	-	-	-	-	-	X	2	1	X	-	1
Ammonium Phosphate Solutions	Liquid	1	1	1	1	1	1	1	1	1	1	1	1	-	1	X	2	1	X	-	1
Ammonium Polysulfide Solution	Yellow Solution	1	1	1	-	-	-	-	-	-	-	-	-	-	-	-	-	-	-	-	-
Ammonium Sulfate	Gray to White Crystals	1	1	-	-	-	-	1	-	-	-	-	1	-	-	1	1	1	X	X	1
Ammonium Sulfide	Yellow Crystals	1	1	-	-	-	-	1	-	-	-	-	-	-	-	1	1	1	X	X	1
Ammonium Sulfide Solution (40-44% or less)	Liquid	1	1	-	1	2	1	1	-	1	1	1	1	-	1	1	1	1	X	X	1
Ammonium Thiocyanate (50-60% or less)	In Water	1	1	1	1	1	1	1	1	-	1	1	1	-	-	1	1	1	-	-	1
Amyl Acetate (Banana or Pearl Oil)	Colorless Liquid	1	1	1	2	X	X	X	X	2	X	X	X	1	X	X	1	1	X	1	X
Amyl Alcohol	Colorless Liquid	1	2	2	2	2	2	2	2	2	1	2	1	1	2	1	1	1	1	1	-

CHEMICAL RESISTANCE TABLE

THE WORLD OF HOSE

Chemical	Form (at room temperature unless otherwise stated)	Gates Hose / Polymers													Couplings / Adapters							
		Teflon®	XLPE	UHMWPE	EPDM	NBR	SBR	NR	CR	Butyl	Fluorocarbon	Hypalon®	CPE	Nylon	PVC	Iron/Carbon Steel	Stainless Steel 304	Stainless Steel 316	Aluminum	Brass	Polypro	
Amyl Chloride (Chloropentane)	Colorless Liquid	1	-	-	-	-	-	-	-	-	-	-	-	-	X	-	1	1	-	-	X	
Amyl Chlorides (mixed)	Straw to Purple Liquid	1	2	2	X	X	X	X	X	X	1	X	2	1	X	-	1	1	-	-	X	
Amyl Chloronaphthalene	-	1	1	2	X	X	X	X	X	X	1	X	X	1	-	-	1	1	-	-	-	
Amyl Naphthalene	-	1	1	-	X	X	X	X	X	X	1	X	X	-	-	-	1	1	-	-	-	
Amyl Phenol	Clear Straw Colored Liquid	1	2	-	-	-	-	-	-	-	-	-	-	-	-	-	1	1	-	-	-	
Amylamine	Colorless Liquid	1	X	-	X	2	-	X	X	X	X	X	-	-	-	-	-	-	-	-	-	
Amylbenzene (sec amylbenzene)	Clear Liquid	1	2	2	X	2	X	X	2	X	1	-	-	-	-	-	-	-	-	-	-	
Anethole (anis camphor)	White Crystals/Liquid > 73°F(23°C)	1	2	-	-	X	X	X	X	X	1	X	X	X	-	2	1	1	2	X	1	
Anhydrous Ammonia (R 717)	Gas or Liquid	NO HOSE AVAILABLE																				
Aniline	Colorless Oily Liquid	1	2	X	2	X	X	X	X	2	1	X	2	X	-	2	1	1	2	X	1	
Aniline Dyes	-	1	1	-	2	X	X	X	X	2	2	X	2	-	-	X	1	1	-	-	2	
Aniline Hydrochloride	White Crystals	1	1	-	2	2	2	2	X	2	-	-	-	-	-	X	X	-	X	2		
Aniline Oil (Aniline)	Colorless Oily Liquid	1	2	X	2	X	X	X	X	2	1	X	2	X	-	2	1	1	2	X	1	
Animal Fat (Lard)	White Solid/Liquid > 108°F(42°C)	1	1	1	X	1	X	X	2	X	1	X	1	1	-	1	1	1	1	X	-	
Animal Gelatin	-	1	-	1	-	1	-	-	1	-	-	-	-	-	-	1	1	1	-	-	-	
Animal Grease, Inedible, Liquid	Liquid	1	-	-	X	1	-	X	2	X	1	2	-	-	-	-	-	-	-	-	-	
Animal Oils	Solid to Liquid	1	-	-	-	1	-	-	2	-	-	-	1	1	1	1	1	1	1	-	-	
Ant Oil (Furfural)	Colorless to Reddish Brown Liquid	1	1	-	X	X	X	X	2	X	2	2	1	-	X	2	1	1	1	1	2	
Antifreeze (Glycol Base)	Liquid	1	1	2	1	1	1	1	1	1	1	1	1	1	1	1	1	1	1	1	1	
Antimony Chloride (50%)	White Powder	1	1	1	-	-	-	-	2	1	-	-	1	1	X	X	X	-	-	1	-	
Antimony Pentachloride	Reddish-yellow Liquid	1	1	1	-	-	-	-	-	1	-	-	-	-	-	-	-	-	-	-	-	
Antimony Salts	White Crystal	1	1	-	1	2	-	-	-	1	1	-	-	-	-	1	-	-	-	-	-	
Aqua Ammonia (Ammonium Hydroxide) (30%)	Colorless Liquid	1	1	1	1	2	2	2	2	2	2	1	1	X	X	2	1	1	-	X	1	
Aqua Regia (Nitrohydrochloric Acid)	Fuming Yellow Liquid	1	2	X	X	X	X	X	X	X	1	X	2	X	X	-	X	X	-	X	-	
Argon, Compressed	Colorless Gas	1	1	1	1	1	1	1	1	1	1	1	1	1	1	-	-	-	-	-	-	
Aromatic Hydrocarbons	Typically Colorless Liquids	1	2	2	X	2	X	X	X	X	1	X	X	1	X	1	1	1	2	2	-	
Arsenic Acid	In Water	1	1	1	2	-	X	X	-	2	1	-	1	-	-	2	-	1	2	-	2	
Arsenic Trioxide	In Acid	1	1	1	X	2	X	X	2	X	1	X	-	-	1	-	-	-	-	-	-	
Askarel (Transformer Oil)	Varies	1	2	2	X	X	X	X	X	X	1	X	1	X	1	X	1	1	1	-	1	2
Asphalt	Varies	1	2	X	X	2	X	X	-	X	1	-	-	X	X	1	1	1	-	1	-	
Asphalt (Blown)	Black Solid	-	-	X	-	-	-	1	-	-	-	-	-	-	-	-	-	-	-	-	-	
Asphalt (Cut Back)	Black Liquid	1	X	X	X	2	X	X	2	X	1	X	X	2	X	1	1	1	-	1	-	
Asphalt Emulsion	Black Liquid	-	-	X	-	-	-	-	-	-	-	-	-	-	-	-	-	-	-	-	-	
Asphalt Paint	Black Liquid	1	2	X	X	2	X	X	-	X	1	X	-	2	X	-	-	-	-	-	-	
Asphaltene	In Carbon Disulfide	1	2	X	X	2	X	X	2	X	1	X	X	1	-	-	-	-	-	-	-	
ASTM Oil No. 1	Brown Liquid	1	1	1	X	1	X	X	1	X	1	2	1	1	2	1	1	1	1	1	2	
ASTM Oil No. 2	Brown Liquid	1	1	1	X	1	X	X	2	X	1	2	1	1	X	1	1	1	1	1	X	
ASTM Oil No. 3	Brown Liquid	1	1	1	X	1	X	X	X	X	1	X	1	1	X	1	1	1	1	1	X	
ASTM Reference Fuel A	Liquid	1	1	1	X	1	X	X	1	X	1	1	1	1	2	1	1	1	1	1	X	
ASTM Reference Fuel B	Liquid	1	2	1	X	1	X	X	2	X	1	X	2	1	X	1	1	1	1	1	X	
ASTM Reference Fuel C	Liquid	1	2	2	X	2	X	X	X	X	1	X	2	1	X	1	1	1	-	1	X	
ATF (Automatic Transmission Oil)	Liquid	1	1	1	X	1	-	-	-	X	1	-	1	-	-	-	-	-	-	-	-	
B																						
Baltic Types 100, 150, 200, 300, 500	Liquid	1	1	-	X	1	-	-	-	X	-	-	-	-	2	-	-	-	-	-	2	
Banvel (Ag Spray, Concentrated)	Liquid	1	1	-	-	-	-	-	-	-	-	-	-	1	-	-	-	-	-	-	-	
Bardol B	Dark colored Liquid	1	1	-	X	X	X	X	X	X	2	X	-	-	-	1	1	1	-	-	-	
Barite (Natural Barium Sulfate)	White to Yellowish Powder	-	-	-	-	-	1	-	-	-	-	-	-	-	-	1	1	1	-	2	1	
Barium Carbonate	White Powder	1	1	-	X	1	X	1	1	X	1	X	X	-	1	2	1	1	-	1	1	
Barium Chloride	Colorless Crystals	1	1	1	1	1	1	1	1	1	1	1	1	1	X	1	X	1	-	2	1	
Barium Hydroxide	White Powder	1	1	1	1	1	X	1	1	1	1	-	1	1	-	X	2	1	1	-	1	
Barium Sulfate	White to Yellowish Powder	-	-	-	-	-	-	1	-	-	-	-	-	-	-	1	1	1	-	2	1	
Barium Sulfide	Yellowish Green to Gray Powder	1	1	1	-	-	-	1	-	-	1	-	-	-	-	X	1	1	-	X	1	

Chemical	Form (at room temperature unless otherwise stated)	Gates Hose / Polymers														Couplings / Adapters						
		Teflon®	XLPE	UHMWPE	EPDM	NBR	SBR	NR	CR	Butyl	Fluorocarbon	Hypalon®	CPE	Nylon	PVC	Iron/Carbon Steel	Stainless Steel 304	Stainless Steel 316	Aluminum	Brass	Polypro	
Basic Copper Arsenate	Blue to Green Powder	1	1	-	-	-	2	1	-	-	1	2	-	-	1	1	1	1	-	-	-	
BBP (Butyl Benzyl Phthalate)	Clear Oily Liquid	1	-	-	-	X	-	X	-	1	X	X	-	-	-	-	-	-	-	-	-	
Beer	Yellow Liquid	-	-	-	-	-	-	-	-	-	-	-	-	-	-	-	-	-	-	-	-	
Beet Sugar Liquors	Colorless Solution	1	1	1	1	1	1	1	1	1	1	1	1	1	1	X	X	X	X	-	X	
Bellows 80-20 Hydraulic Oil	Liquid	1	1	-	X	1	-	-	-	X	-	-	-	-	2	-	-	-	-	-	X	
Benzaldehyde (Benzoic Aldehyde)	Colorless to Yellow Liquid	1	1	1	2	X	X	X	X	X	2	X	X	2	2	X	1	-	-	1	-	1
Benzene (Benzol)	Colorless to Yellow Liquid	1	2	X	X	X	X	X	X	X	1	X	X	1	X	1	1	1	1	1	1	X
Benzenesulfonic Acid	Liquid above 151°F (66°C)	1	1	1	-	-	X	X	X	2	1	2	-	-	X	X	-	2	X	-	1	
Benzidine	Paste	1	2	-	X	2	X	1	X	X	-	-	-	-	X	1	1	1	1	1	1	X
Benzoic Acid	White Crystals	1	1	1	2	X	X	X	X	2	1	2	1	-	X	-	-	-	-	-	-	
Benzoic Aldehyde (Benzaldehyde)	Colorless to Yellow Liquid	1	1	1	2	X	X	X	X	2	X	X	2	2	X	1	-	-	1	-	1	
Benzol (Benzene)	Colorless to Yellow Liquid	1	2	X	X	X	X	X	X	X	1	X	X	1	X	1	1	1	1	1	1	X
Benzophenone	White Powder	1	1	-	-	-	-	1	-	-	1	-	-	-	-	-	-	-	-	-	-	
Benzotrithloride	Colorless to Yellow Liquid	1	-	-	X	X	X	X	X	X	1	-	X	2	X	-	-	-	-	-	-	
Benzyl Acetate	Water White Liquid	1	2	2	-	-	-	-	-	-	-	-	-	-	-	-	-	-	-	-	-	
Benzyl Alcohol	Water White Liquid	1	1	1	2	X	X	X	X	1	1	X	1	X	1	-	-	-	-	-	-	
Benzyl Alcohol, Photo Inhibited	Water White Liquid	1	-	-	-	-	-	-	-	-	-	-	-	-	-	1	1	1	-	-	1	
Benzyl Benzoate	Water White Liquid	1	1	-	2	-	-	-	-	2	1	-	-	-	-	1	1	1	-	-	-	
Benzyl Chloride	Colorless Liquid	1	2	2	X	X	X	X	X	X	1	-	X	2	X	1	-	-	-	-	-	
Bicarbonate Of Soda	White Powder	-	-	-	-	-	-	1	-	-	-	-	-	-	-	-	-	-	-	-	-	
Bismuth Carbonate	White Powder	1	-	-	-	-	-	1	X	-	-	-	-	-	-	1	1	1	-	-	1	
Bisphenol A	White Flakes	-	-	-	-	-	-	1	-	-	-	-	-	-	-	-	-	-	-	-	-	
Bitumastic	Liquid	1	-	X	X	2	X	X	2	X	2	X	2	-	-	1	1	1	-	1	-	
Black Liquor (RXN Product Pulpwood+NaOH)	Black Alkaline Liquid	1	1	1	2	2	X	X	2	2	1	2	2	-	1	1	1	1	-	-	1	
Black Sulfate Liquor (See "Black Liquor")	Black Alkaline Liquid	1	1	1	2	2	X	X	2	2	1	2	2	-	1	1	1	1	-	-	1	
Blast Furnace Gas (Cooled)	Gas	1	1	-	-	X	X	X	X	X	1	X	-	-	X	1	1	1	-	1	-	
Bleach (Chlorinated Lime)	White Powder (35-37% Cl)	-	-	-	-	-	-	1	-	-	-	-	-	-	-	-	-	-	-	-	-	
Bleach Liquor (Calcium Hypochlorite/H2O)	Clear Solution	1	1	1	2	-	-	-	-	-	1	-	1	-	-	-	-	-	-	-	-	
Borax (Sodium Borate)	White Crystals	1	1	-	1	1	1	1	1	1	1	1	1	1	1	2	1	1	-	2	1	
Bordeaux Mixture (Slaked Lime & Copper Sulfate)	In Water	1	1	1	1	1	2	2	2	1	1	-	-	-	1	-	1	1	-	-	-	
Boric Acid	White Powder or Colorless Scale	1	1	1	1	1	1	1	1	1	1	1	1	X	1	X	2	1	1	X	1	
Boric Oxide	Colorless Powder	1	-	-	-	-	-	1	-	-	-	-	-	-	1	-	-	-	-	-	-	
Brake Fluid (Petroleum Base)	Liquid	1	1	-	X	1	X	X	2	X	1	X	1	1	2	1	1	1	-	1	X	
Brake Fluid (Synthetic Base)	Liquid	1	1	-	1	X	X	X	X	1	X	X	1	-	2	1	1	1	-	1	-	
Brine (Salt)	Liquid	1	1	1	1	1	1	1	1	1	1	1	1	1	1	2	1	1	-	2	1	
Bromine	Dark Reddish Brown Liquid	1	-	-	X	X	-	-	X	-	1	-	-	X	X	1	1	1	1	1	-	
Bromobenzene	Colorless Liquid	1	-	-	X	-	X	X	-	X	1	-	-	-	X	-	-	-	-	-	-	
Bromochloroethane	Colorless Liquid	-	-	X	X	-	X	X	-	X	X	-	X	X	-	-	-	-	-	-	-	
Bromochloromethane (Chlorobromomethane)	Clear Liquid	1	2	X	X	X	X	X	X	X	X	X	X	X	X	1	1	1	-	1	X	
Bromotoluene	Clear Liquid	1	-	-	X	-	X	X	-	X	1	-	X	-	X	-	-	-	-	-	-	
Bubble Bath Compounds	Liquid	1	-	1	-	-	-	-	-	-	-	-	-	-	-	-	-	-	-	-	-	
Bunker Oil	Liquid	1	2	2	X	1	X	X	2	X	1	X	-	1	X	1	1	1	1	1	-	
Butadiene (1,3)	Gas	1	1	-	X	2	X	X	X	X	1	X	-	1	X	-	1	1	-	1	1	
Butanal (Butyraldehyde)	Water White Liquid	1	2	-	X	X	X	X	X	X	X	X	2	-	-	-	-	-	-	1	-	
Butandiol (Butylene Glycol)	Colorless Oily Liquid	1	1	2	-	-	-	-	-	-	1	-	-	X	-	-	-	-	-	-	-	
Butane [Gas]	Colorless Gas	USE LPG HOSE ONLY														-	-	-	-	-	-	
Butane [Liquid]	Liquid	USE LPG HOSE ONLY														-	-	-	-	-	-	
Butanol (Butyl Alcohol)	Colorless Liquid	1	1	1	1	1	1	1	2	1	1	2	1	1	1	1	1	1	1	1	1	
Butter	Yellow to white semi-Solid to Liquid	-	-	-	-	-	-	-	-	-	-	-	2	-	-	-	-	-	-	-	-	
Butter Oil (Use FDA Hose)	Yellow to white Liquid	1	-	-	-	-	X	X	2	-	-	-	-	-	-	1	1	1	1	1	-	
Butyric Acid	Colorless Liquid	1	1	1	2	-	2	2	X	2	1	X	1	X	-	-	-	-	-	-	-	
Butyl Carbitol (Diethylene Glycol Butyl Ether)	Colorless Liquid	1	1	-	2	2	X	X	2	2	1	-	1	-	-	1	1	1	1	1	-	

CHEMICAL RESISTANCE TABLE

THE WORLD OF HOSE

Chemical	Form (at room temperature unless otherwise stated)	Gates Hose / Polymers														Couplings / Adapters					
		Teflon®	XLPE	UHMWPE	EPDM	NBR	SBR	NR	CR	Butyl	Fluorocarbon	Hypalon®	CPE	Nylon	PVC	Iron/Carbon Steel	Stainless Steel 304	Stainless Steel 316	Aluminum	Brass	Polypro
Butyl Cellulosolve (EG Monobutyl Ether)	Colorless Liquid	1	1	-	1	-	-	-	-	-	-	1	-	1	-	-	-	-	-	-	-
Butyl "Oxito™" for EG Monobutyl Ether	Colorless Liquid	1	1	-	1	-	-	-	-	-	-	1	-	1	-	-	-	-	-	-	-
Butyl Acetate	Colorless Liquid	1	2	2	X	X	X	X	X	2	X	X	2	1	1	2	1	1	1	1	X
Butyl Acrylate	Colorless Liquid	1	-	-	-	-	-	-	-	-	X	-	-	-	-	-	-	-	-	-	-
Butyl Alcohol (Butanol)	Colorless Liquid	1	1	1	1	1	1	1	2	1	1	2	1	1	1	1	1	1	1	1	1
Butyl Aldehyde	Water White Liquid	1	-	-	2	X	-	-	X	-	X	X	-	-	-	-	-	-	-	-	-
Butyl Benzyl Phthalate (BBP)	Clear Oily Liquid	1	-	-	-	X	-	X	-	1	X	X	-	-	-	-	-	-	-	-	-
Butyl Chloride	Colorless Liquid	1	-	-	-	-	-	-	-	-	1	-	-	-	-	-	-	-	-	-	-
Butyl Ether	Colorless Liquid	1	1	-	-	2	X	X	2	2	X	-	1	-	-	1	1	1	1	1	-
Butyl Ethyl Ether (Ethyl-n-Butyl Ether)	Liquid	1	-	-	-	2	-	X	-	X	-	2	-	-	-	-	-	-	-	-	-
Butyl Formate	Colorless Liquid	1	-	-	-	X	-	X	X	-	-	-	-	-	-	-	-	-	-	-	-
Butyl Mercaptan [2-Methyl-2-Butanathiol]	Liquid	1	1	-	X	-	X	X	-	X	1	-	-	-	X	-	1	1	-	-	-
Butyl Methacrylate	Colorless Liquid	1	-	-	-	-	-	-	-	-	-	-	-	-	-	-	-	-	-	-	-
Butyl Stearate	Colorless Liquid	1	1	-	X	2	X	X	X	X	1	-	2	-	1	1	1	1	1	1	-
Butylamine	Colorless Liquid	1	1	-	-	X	X	X	X	X	X	2	-	-	-	1	1	1	1	1	X
Butylene Glycol (Butandiol)	Colorless Oily Liquid	1	1	2	-	-	-	-	-	-	1	-	-	X	-	-	-	-	-	-	-
Butyraldehyde (Butanal)	Water White Liquid	1	2	-	X	X	X	X	X	X	X	2	-	-	-	-	-	-	-	1	-
Butyric Acid	Colorless Liquid	1	1	1	1	-	-	-	-	1	1	X	1	1	1	X	1	1	1	2	-
Butyric Anhydride	Water White Liquid	1	-	-	-	-	-	-	-	-	-	-	-	-	-	-	-	-	-	-	-
C																					
Cadmium Acetate (Soluble in H2O & Alcohols)	In Water or Alcohol	1	-	-	-	X	-	X	-	1	X	-	-	-	-	-	-	-	-	-	-
Cake Alum (Aluminum Sulfate)	White Crystals	1	1	-	1	1	-	1	1	-	-	-	-	-	-	X	X	2	X	X	1
Cake Alum Solution (Al Sulphate up to 50%)	In Water	1	1	1	1	1	-	-	-	1	1	-	1	1	1	-	-	-	-	-	-
Calcine Liquor (Radioactive Waste)	In Water Solution	1	1	-	1	1	-	-	-	1	1	-	-	-	-	1	1	1	2	-	-
Calcium Acetate	Powder	1	1	-	1	X	2	2	X	1	X	X	1	-	-	1	1	1	1	1	-
Calcium Aluminate (Soluble in Acids)	In Acid	1	-	-	-	1	-	1	1	1	1	1	-	-	-	-	-	-	-	-	-
Calcium Aluminate (Tricalcium Aluminate)	Crystals or Powder	1	-	-	-	-	-	1	-	-	-	-	-	-	-	-	-	-	-	-	-
Calcium Arsenate	In Dilute Acid	1	1	-	-	-	-	-	-	-	1	-	-	-	-	-	-	-	-	-	-
Calcium Bisulfide (Calcium Hydrosulfide)	In Alcohol or Water	1	1	-	-	1	2	2	1	1	1	1	1	-	2	-	2	1	-	X	1
Calcium Bisulfite (Calcium Hydrogen Sulfite)	Yellow Liquid	1	1	-	-	1	2	2	1	1	1	1	1	-	1	-	1	1	-	-	1
Calcium Bromide Solution	In Water or Alcohol	1	1	1	-	-	-	-	-	-	1	-	-	-	-	-	-	-	-	-	-
Calcium Carbonate	Solid White Powder	1	1	-	1	1	1	1	1	1	1	1	1	1	1	1	1	1	1	1	1
Calcium Carbonate Slurry	Solid in H2O	1	-	-	1	1	1	1	1	1	1	1	-	-	-	-	-	-	-	-	-
Calcium Chlorate	In Water or Alcohol	1	1	-	2	1	2	2	1	2	-	1	-	-	1	-	2	1	-	-	1
Calcium Chloride, Dry	White solid	-	-	-	-	-	1	-	-	-	-	-	-	-	-	X	2	1	-	2	1
Calcium Chloride, Liquid (Not For Food)	In Water or Alcohol	1	1	-	1	1	1	1	1	1	1	1	1	X	1	-	-	-	-	-	-
Calcium Chloride, Liquid, Food Grade 33%	In Water	1	-	-	1	1	1	1	1	1	1	1	1	1	1	-	-	-	-	-	-
Calcium Hydrogen Sulfite (Calcium Bisulfite)	Yellow Liquid	1	1	-	-	1	2	2	1	1	1	1	1	-	1	-	1	1	-	-	1
Calcium Hydrosulfide (Calcium Bisulfide)	In Alcohol or Water	1	1	-	-	1	2	2	1	1	1	1	1	-	2	-	2	1	-	X	1
Calcium Hydroxide (Hydrated or Slaked Lime)	Solid White Powder	1	1	-	-	2	1	1	1	1	X	1	1	-	X	X	X	1	-	2	1
Calcium Hydroxide Solutions	In Glycerol or Acids	1	1	X	-	2	-	-	-	-	-	-	X	-	2	1	1	X	X	-	-
Calcium Hypochlorite	Solid White Crystals	1	2	X	-	-	X	X	X	2	-	2	1	X	2	-	-	-	-	-	-
Calcium Hypochlorite Solutions	In Water or Alcohol	1	1	X	-	-	X	X	X	2	-	2	1	-	1	-	X	2	X	X	1
Calcium Metasilicate (Calcium Silicate)	White Powder	1	1	-	-	2	2	1	-	2	1	2	1	-	1	1	1	1	1	1	-
Calcium Nitrate Solutions	In Water, Alcohol, or Acetone	1	1	-	1	1	1	1	1	1	1	1	1	-	1	1	1	1	1	1	1
Calcium Oxide (Lime; quick, unslaked)	White to Gray Lumps	-	-	-	-	-	1	-	-	-	-	-	-	-	-	-	2	-	-	-	-
Calcium Silicate (Calcium Metasilicate)	White Powder	1	1	-	-	2	2	1	-	2	1	2	1	-	1	1	1	1	1	1	-
Calcium Stearate	White Powder	-	-	-	-	-	-	1	-	-	-	-	-	-	-	-	-	-	-	-	-
Calcium Sulfate	White Powder or Crystals	1	1	-	1	1	-	1	1	1	1	1	1	-	-	1	1	1	-	1	1
Calcium Sulfide	Yellow to Gray Powder	1	1	-	-	1	2	1	2	1	2	1	1	-	2	1	1	1	2	-	-
Calcium Sulfite (Soluble In Sulfurous Acid)	In Acid	1	1	1	1	-	-	-	-	X	1	-	1	-	-	-	-	-	-	-	-
Caliche Liquors (Sodium Nitrate)	In Water	1	1	-	-	1	2	2	-	1	-	1	-	-	-	-	1	1	-	-	-

Chemical	Form (at room temperature unless otherwise stated)	Gates Hose / Polymers														Couplings / Adapters					
		Teflon®	XLPE	UHMWPE	EPDM	NBR	SBR	NR	CR	Butyl	Fluorocarbon	Hypalon®	CPE	Nylon	PVC	Iron/Carbon Steel	Stainless Steel 304	Stainless Steel 316	Aluminum	Brass	Polypro
		1 = Preferred - Constant Contact 2 = Acceptable - Intermittent Contact X = Not Recommended - = No Data NOTE: Ratings are for the affect on the polymer only!																			
Camphene (Liquid above 115°F [46°C])	Liquid above 115°F [46°C]	1	-	-	X	-	-	-	-	-	1	X	-	-	-	-	-	-	-	-	-
Cane Sugar Liquors	In Water	1	1	-	2	1	2	2	1	2	-	1	1	-	1	1	1	1	1	2	1
Caproic Acid	Colorless or Yellow Liquid	1	1	1	2	-	-	-	-	-	-	1	-	-	-	-	-	-	-	-	-
Caprolactam	White Flakes	-	-	-	-	-	-	1	-	-	-	-	-	-	-	-	-	-	-	-	-
Caprolactam, Molten (above 156°F [69°C])	Liquid	-	-	-	-	-	-	-	-	-	-	-	X	-	-	-	-	-	-	-	-
Caprylic Acid [Octanoic Acid]	Colorless, Oily Liquid	1	-	-	-	-	-	-	-	-	-	1	-	-	-	-	-	-	-	-	-
Carbamates	Crystals	1	1	-	X	X	X	X	X	X	2	X	-	-	-	-	-	-	-	-	-
Carbolic Acid	Liquid above 109°F [43°C]	1	2	2	2	X	X	X	X	2	1	X	1	X	X	X	1	1	2	X	-
Carbolic Acid [Phenol]	White or Pink Crystals	1	2	-	2	X	X	X	X	2	1	X	1	X	X	X	1	1	2	X	-
Carbolic Acid [Phenol, 82-95% in Creosols]	Liquid	1	2	-	2	X	X	X	X	2	2	X	1	X	X	X	1	1	2	X	-
Carbon Dioxide (Dry)	Gas	1	1	-	1	1	1	1	1	1	1	1	-	-	1	1	1	1	1	1	1
Carbon Dioxide (Wet)	Gas with Water Vapor	1	1	1	2	1	2	2	1	2	1	1	-	-	1	1	1	1	1	1	1
Carbon Disulfide	Clear to Faint Yellow Liquid	1	2	1	X	2	X	X	X	X	1	X	2	1	X	2	1	1	2	2	X
Carbon Monoxide	Gas	1	2	1	1	2	X	X	2	X	1	1	-	-	1	1	1	1	1	1	1
Carbon Tetrachloride (Pyrene)	Colorless Liquid	1	2	X	X	X	X	X	X	X	1	X	2	1	X	X	2	2	X	2	X
Carbolic Acid	Liquid	1	1	1	1	1	1	1	1	1	1	1	1	-	X	X	1	1	2	X	1
Carbonyl Chloride (Phosgene)	Gas/ Liquid	1	X	X	X	X	X	X	X	1	1	X	-	2	-	-	-	-	-	-	-
Casein [White amorphous solid]	In Concentrated Acid	1	-	-	-	-	-	-	-	-	1	-	-	-	1	-	-	-	-	-	-
Castor Oil	Pale Yellow or Colorless Liquid	1	1	-	-	1	X	X	1	2	1	1	1	-	1	1	1	1	1	1	1
Caustic Potash, Dry [Potassium Hydroxide]	White pellets or flakes	1	1	-	2	X	2	1	2	1	1	1	1	X	X	-	-	-	-	-	-
Caustic Potash, Liquid (up to 45%)	Solution in Water	1	1	1	2	2	2	2	-	1	2	-	1	1	1	-	-	-	-	-	-
Caustic Soda, Dry [Sodium Hydroxide]	White beads or pellets	-	-	-	-	-	-	1	-	-	-	-	-	-	-	-	-	-	-	-	-
Caustic Soda, Liquid (up to 73%)	Solution in Water	1	2	-	2	X	1	1	2	2	X	1	1	2	X	-	-	-	-	-	-
Cellosolve Acetate [Eg Ethyl Ether Acetate]	Colorless Liquid	1	1	-	2	X	-	-	-	X	-	1	-	1	1	1	1	-	-	-	1
Cellosolve Butyl [Eg Butyl Ether]	Colorless Liquid	1	1	-	2	X	-	-	-	X	-	1	-	1	1	1	1	-	-	-	1
Cellulose	Solid, many forms	1	1	1	1	1	1	1	1	1	1	1	1	-	-	-	-	-	-	-	-
Cement, Portland	Gray Powder	1	-	1	-	-	-	1	-	-	-	-	-	-	-	-	-	-	-	-	-
China-Wood Oil [Tung Oil]	Yellow Oil	1	2	-	X	2	X	X	X	X	1	2	-	-	2	1	1	1	1	1	-
Chlordane	Colorless Viscous Liquid	1	1	-	X	X	-	-	X	-	1	X	-	1	2	-	-	-	-	-	-
Chlorinated Napthalene [Chloronapthalene]	Oily Liquid to Solid	1	-	-	X	X	X	X	X	X	1	X	-	-	-	-	-	-	-	-	-
Chlorinated Solvents [ie Tetrachloroethane]	Colorless Liquid	1	X	X	X	-	X	X	-	X	1	X	X	1	X	-	-	-	-	-	-
Chlorine	Gas	NO HOSE AVAILABLE																			
Chlorine Liquid [Liquid @ 210 PSIG @ 120°F [38°C]	Clear Amber Liquid	1	-	-	X	-	-	-	-	-	1	-	-	X	X	-	-	-	-	-	-
Chlorine Trifluoride	Pale Green Liquid	1	-	-	X	-	-	-	-	-	1	-	-	-	X	-	-	-	-	-	-
Chlorine Water [3% Chlorine]	Clear, yellowish Liquid	1	1	1	X	-	-	-	-	-	1	-	-	-	-	-	X	X	-	-	1
Chloroacetic Acid [Monochloroacetic Acid]	Powder or White Crystals	1	1	X	X	X	X	X	X	X	1	2	-	-	-	-	-	-	-	-	-
Chloroacetic Acid Under 100°F [38°C]	Solid	1	1	1	X	X	X	X	X	X	1	2	-	-	-	-	-	-	-	-	-
Chloroacetic Acid Solution	In Water, Alcohol, Ether	1	1	X	2	-	-	-	-	-	-	-	-	X	-	X	X	X	-	2	1
Chloroacetone	Colorless Liquid	-	-	-	1	-	-	-	-	-	X	-	-	-	-	-	-	-	-	-	-
Chloroacetyl Chloride	Water White Liquid	1	-	-	-	-	-	-	-	-	-	-	-	-	1	-	-	-	-	-	-
Chloroaniline	Amber Liquid	1	-	-	-	-	-	-	-	-	-	-	-	-	-	-	-	-	-	-	-
Chlorobenzene [Phenyl Chloride] [Monochlorobenzene]	Clear Liquid	1	2	-	X	X	X	X	X	X	1	X	X	X	X	1	1	1	1	1	X
Chlorobromomethane [Bromochloromethane]	Clear Liquid	1	2	X	X	X	X	X	X	X	X	X	X	X	X	1	1	1	-	1	X
Chlorodifluoromethane [Freon 22]	Gas	SPECIAL HOSE REQUIRED																			
Chloroethane [Ethylene Dichloride]	Colorless Liquid	1	2	2	X	X	X	X	X	X	1	X	X	X	X	-	-	-	-	-	-
Chloroform	Colorless Liquid	1	2	2	X	X	X	X	X	X	1	X	X	2	X	1	1	1	1	1	X
Chloronapthalene [Chlorinated Napthalene]	Oily Liquid to Solid	1	-	-	X	X	X	X	X	X	1	X	-	-	-	-	-	-	-	-	-
Chloropentane [n-amyl chloride]	Colorless Liquid	1	-	-	-	-	-	-	-	-	-	-	-	-	X	-	1	1	-	-	X
Chlorophenol	In Benzene, Alcohol, Ether	1	2	-	-	-	-	-	-	-	-	-	-	-	-	-	-	-	-	-	-
Chloropicrin Mixture	Colorless Liquid	1	-	-	-	-	-	-	-	-	-	-	-	-	X	-	-	-	-	-	-
Chloropropylene Oxide [Epichlorohydrin]	Volatile Liquid	1	2	-	X	-	-	-	-	-	X	-	-	-	-	1	-	-	-	-	1
Chlorosulfonic Acid	Colorless to Light Yellow Liquid	NO HOSE AVAILABLE																			

CHEMICAL RESISTANCE TABLE

THE WORLD OF HOSE

Chemical	Form (at room temperature unless otherwise stated)	Gates Hose / Polymers													Couplings / Adapters						
		Teflon®	XLPE	UHMWPE	EPDM	NBR	SBR	NR	CR	Butyl	Fluorocarbon	Hypalon®	CPE	Nylon	PVC	Iron/Carbon Steel	Stainless Steel 304	Stainless Steel 316	Aluminum	Brass	Polypro
Chlorothene (TM for chlorinated solvents)	Colorless Liquid	1	1	X	-	X	-	-	X	-	2	-	-	-	-	1	1	-	1	-	-
Chlorotoluene	Colorless Liquid	1	-	-	X	X	X	X	X	X	1	X	X	-	X	1	1	1	1	1	-
Chlorox	Colorless Liquid	1	2	1	-	-	2	2	2	2	2	1	1	1	-	2	1	-	-	-	X
Chocolate Syrup	Liquid	-	-	-	-	-	-	-	-	-	-	-	1	1	-	-	-	-	-	-	-
Chrome Alum (Chromium Potassium Sulfate)	In Water	1	1	-	1	1	1	1	1	1	1	1	-	1	1	-	-	-	-	-	1
Chromic Acid (100%)	Dark Red Crystals	1	X	2	-	-	-	-	-	1	-	-	-	X	X	X	X	X	X	X	-
Chromic Acid (25% Solution or less)	In Water	1	1	1	2	X	X	X	X	X	1	2	1	X	X	X	X	2	X	X	1
Chromic Acid (50% Solution with water)	In Water	1	1	1	2	X	X	X	X	X	1	2	1	X	X	X	X	2	X	X	1
Chromic Acid (Chromium Trioxide)	Purplish-Red Crystals	1	X	2	-	-	-	-	-	-	1	-	-	-	X	X	X	2	X	X	1
Chromic Chloride	In Water	1	-	-	-	-	-	-	-	-	-	-	-	1	-	-	-	-	-	-	-
Chromium Trioxide (Chromic Acid)	Purplish-Red Crystals	1	X	2	-	-	-	-	-	1	-	-	-	X	X	X	2	X	X	1	-
Cider	Liquid	1	-	-	-	-	-	-	-	-	-	-	-	-	2	-	-	-	-	-	-
Cinene (Dipentene)	Colorless Liquid	1	2	-	X	X	X	X	-	1	-	-	-	-	-	-	-	-	-	-	-
Citgo FR Fuels	Liquid	1	1	-	1	X	-	-	-	1	-	-	-	2	-	-	-	-	-	-	-
Citric Acid Solution	In Water	1	1	1	2	X	2	2	1	2	1	1	-	X	1	X	X	1	1	X	2
Coal Gas (Coke Oven Gas, Max 120°F [49°C])	Gas	1	-	-	-	-	-	-	-	-	-	1	-	1	-	-	-	-	-	-	-
Coal Tar	Black, viscous Liquid	1	-	-	X	2	X	X	2	X	1	X	2	X	X	1	1	1	1	1	-
Coal Tar Pitch (Roofing)	Liquid above 212°F [100°C]	1	-	-	X	2	X	X	2	X	1	2	2	-	X	-	-	-	-	-	-
Cobalt Nickel Plating Solution	Liquid	1	1	-	-	-	-	-	-	-	-	-	-	X	-	-	-	2	-	-	-
Cocoa Butter (Theobroma Oil)	Liquid above 95°F [35°C]	1	1	2	-	2	X	X	2	-	-	-	-	-	1	1	1	-	-	-	-
Coconut Oil	Liquid above 77°F [25°C]	1	-	-	2	1	X	X	1	2	1	2	-	1	2	-	-	-	-	-	-
Cod Liver Oil	Pale Yellow Liquid	1	1	-	2	X	X	X	X	2	1	X	-	-	-	1	1	1	1	1	-
Coke Oven Gas (300°F [149°C] or less)	Gas	1	1	-	X	X	X	X	X	X	1	2	-	-	-	1	1	1	2	-	1
Copper Arsenate (Cupric Arsenate)	In Dilute Acid	1	1	-	-	-	2	2	-	-	1	2	-	-	-	1	1	1	-	-	-
Copper Chloride (Cupric Chloride)	In Water	1	1	-	-	2	2	2	2	2	1	2	2	X	1	X	X	1	-	X	1
Copper Cyanide (Cupric Cyanide)	In Dilute Acids or Alkalies	1	1	-	2	2	2	2	2	2	1	2	-	-	1	-	1	1	-	X	1
Copper Nitrate (Cupric Nitrate)	In Water	1	1	-	1	1	2	2	1	1	1	1	1	-	1	X	1	1	-	X	1
Copper Sulfate (Cupric Sulfate)	In Water	1	1	-	2	1	2	2	1	2	1	1	1	X	1	X	1	1	X	X	1
Copper Sulfide (Soluble in Nitric Acid)	In Nitric Acid	1	-	-	-	1	-	X	-	1	1	1	-	-	-	-	-	-	-	-	-
Corn Oil	Pale Yellow Liquid	1	1	-	2	2	X	X	2	2	1	X	2	-	1	1	1	1	1	1	X
Corn Syrup (Glucose Syrup)	Clear Liquid	1	2	-	2	2	2	2	2	2	2	2	-	-	-	1	1	1	1	-	-
Cottonseed Oil	Liquid, several colors	1	1	-	2	2	-	-	1	-	1	2	2	-	-	1	1	1	1	1	1
Creosote (high Napthalene/Anthracene)	Liquid	X	2	X	-	2	X	X	X	2	1	X	-	-	X	2	1	1	1	X	2
Cresol (Methyl Phenol)	Liquid above 95°F [35°C]	1	2	-	-	X	X	X	X	2	1	X	1	X	-	2	1	1	1	-	2
Cresylic Acid	Liquid	1	-	-	X	X	X	X	X	X	1	X	-	X	-	-	-	-	-	-	-
Crotonic Acid (Methylacrylic Acid)	White Crystalline Solid	1	1	1	2	2	X	X	-	1	1	-	1	X	-	1	X	-	-	-	-
Crude Oil (Crude Petroleum Oil)	Liquid	1	1	-	X	1	X	X	2	X	1	2	2	-	1	1	1	1	1	1	1
Crude Wax	Liquid above 200°F [93°C]	1	2	-	-	2	-	-	-	2	1	-	-	-	1	1	1	1	-	1	1
Cryolite (Greeland Spar)	In Sulfuric Acid	1	2	-	X	1	X	X	2	X	1	X	-	-	-	1	1	1	-	1	X
Cumene (Isopropyl Benzene)	Colorless Liquid	1	2	-	-	-	-	-	-	1	-	2	-	-	-	-	-	-	-	-	-
Cupric Arsenate (Copper Arsenate)	In Dilute Acid	1	1	-	-	-	2	2	-	-	1	2	-	-	-	1	1	1	-	-	-
Cupric Chloride (Copper Chloride)	In Water	1	1	-	-	2	2	2	2	2	1	2	2	X	1	X	X	1	-	X	1
Cupric Cyanide (Copper Cyanide)	In Dilute Acids or Alkalies	1	1	-	2	2	2	2	2	2	1	2	-	-	1	-	1	1	-	X	1
Cupric Nitrate (Copper Nitrate)	In Water	1	1	-	1	1	2	2	1	1	1	1	1	-	1	X	1	1	-	X	1
Cupric Sulfate (Copper Sulfate)	In Water	1	1	-	2	1	2	2	1	2	1	1	1	X	1	X	1	1	X	X	1
Cutting Oil (Mineral Oil Base)	Liquid	1	2	-	X	1	X	X	2	X	1	X	-	-	-	1	1	1	-	1	X
Cutting Oil, Sulfur Base	Liquid	2	-	-	-	1	-	-	X	-	-	-	-	-	-	1	1	1	-	1	1
Cutting Oil, Water Soluble	Liquid	1	-	-	-	1	-	-	X	-	-	-	-	-	-	1	1	1	-	1	1
Cyanide, Copper (Cupric Cyanide)	In Dilute Acids or Alkalies	1	1	-	2	2	2	2	2	2	1	2	-	-	1	-	1	1	-	X	1
Cyanide, Mercuric	In Water	1	1	-	2	2	2	2	1	2	-	1	-	-	-	-	-	-	X	-	1
Cyanide, Potassium	In Water	1	-	-	-	-	-	-	-	-	-	-	1	-	-	-	-	-	-	-	-
Cyanide, Silver	In Nitric Acid	1	1	-	-	-	-	-	1	-	-	-	-	-	1	-	-	-	-	-	1

Chemical	Form (at room temperature unless otherwise stated)	Gates Hose / Polymers														Couplings / Adapters					
		Teflon®	XLPE	UHMWPE	EPDM	NBR	SBR	NR	CR	Butyl	Fluorocarbon	Hypalon®	CPE	Nylon	PVC	Iron/Carbon Steel	Stainless Steel 304	Stainless Steel 316	Aluminum	Brass	Polypro
		1	2	-	X	2	X	X	X	1	X	1	-	X	1	1	1	1	-	X	X
Cyanide, Sodium	In Water	1	1	-	1	1	1	1	1	1	1	1	1	1	1	2	1	1	X	X	-
Cyclohexane	Colorless Liquid	1	2	1	X	2	X	X	X	X	1	X	1	-	X	1	1	1	-	1	X
Cyclohexanol	Colorless, oily Liquid	1	2	-	X	2	X	X	2	X	1	2	1	-	X	-	-	-	-	-	1
Cyclohexanone	Colorless to yellow Liquid	1	1	-	X	X	X	X	X	X	X	X	2	-	X	-	1	1	2	-	X
Cyclohexylamine	Colorless Liquid	-	-	-	1	-	X	-	-	1	X	-	-	-	-	-	-	-	-	-	-
Cyclopentane	Colorless Liquid	1	-	-	X	2	-	X	2	X	1	X	-	-	-	-	-	-	-	-	-
Cyclopentanol	Colorless Liquid	1	-	-	-	2	-	X	-	X	2	X	-	-	-	-	-	-	-	-	-
Cyclopentanone	Water white Liquid	-	-	-	X	-	X	-	X	X	X	X	-	-	-	-	-	-	-	-	-
Cymene	Colorless Liquids	1	2	-	X	X	X	X	X	X	2	X	2	-	X	1	1	1	1	1	-
Cymene (Isopropyltoluene)	Colorless Liquid	1	-	-	-	-	-	-	-	-	1	-	-	1	-	1	1	1	1	1	-
D																					
Decalin (TM for decahydronaphthalene)	Colorless Liquid	1	2	2	X	2	X	X	-	X	1	X	2	1	-	-	-	-	-	1	1
Decanal [Decyl Aldehyde]	Colorless to yellow Liquid	1	-	-	-	X	-	X	-	X	X	X	-	-	-	-	-	-	-	-	-
Decanol [Decyl Alcohol]	Colorless, water white Liquid	1	-	-	-	1	-	X	X	X	2	2	-	-	X	-	-	-	-	-	-
Decyl Aldehyde (n-decanal)	Colorless to yellow Liquid	1	-	-	-	X	-	X	-	X	X	X	-	-	-	-	-	-	-	-	-
Deicing Fluid (ethylene or propylene glycol)	Orange Liquid	1	1	1	1	1	-	-	1	1	1	2	1	-	1	2	1	1	1	1	1
Denatured Alcohol	Colorless Liquid	1	1	1	1	1	1	1	1	1	1	1	1	1	1	1	1	1	1	1	-
Detergent Sol. (Sodium dodecylbenzenesulfonate)	In Water	1	2	1	1	1	X	X	2	1	-	1	-	-	1	2	1	1	1	1	1
Developing Solutions (Hypos)	Liquid	1	1	-	-	-	2	2	2	2	-	2	-	-	1	-	1	1	-	-	-
Dextron	Brown Liquid	1	X	-	X	1	-	-	-	X	-	-	1	1	2	-	-	-	-	-	-
Dextrin (Starch gum)	Yellow or White Powder	1	1	-	1	1	-	-	1	X	1	-	-	1	1	-	1	1	-	-	1
Diacetone	Colorless Liquid	1	1	-	2	X	X	X	X	2	X	X	1	1	X	1	1	1	-	1	1
Diacetone Alcohol	Colorless Liquid	1	1	-	-	X	2	2	-	2	X	2	1	-	X	1	1	1	1	1	1
Diammonium Phosphate	In Water	1	1	-	1	1	1	1	1	1	-	1	-	-	1	X	2	1	X	-	1
Diazinon	In Petroleum Solvents	1	-	-	1	-	1	1	-	-	1	-	-	-	2	-	-	-	-	-	2
Dibenzyl Ether	Colorless Liquid	1	1	-	2	X	X	X	X	2	X	X	2	-	-	1	1	1	1	1	-
Dibutyl Ether	Colorless Liquid	1	1	-	-	X	X	X	X	2	X	X	1	-	-	1	1	1	1	1	-
Dibutyl Phthalate	Colorless Oily Liquid	1	1	-	1	X	X	X	X	2	2	X	2	-	-	1	1	1	1	1	2
Dibutylamine	Colorless Liquid	1	-	-	X	X	X	X	X	X	X	X	X	-	X	-	-	-	-	-	-
Dibutylsebacate	Clear Colorless Liquid	1	1	-	X	X	X	X	X	2	1	-	2	-	-	-	-	-	-	1	-
Dichloroacetic Acid	Colorless Liquid	1	-	-	-	X	-	2	-	X	X	X	-	-	-	-	-	-	-	-	-
Dichloroaniline	In Alcohol or Benzene	1	-	-	X	X	X	-	X	X	2	-	-	-	-	-	-	-	-	-	-
Dichlorobenzene (ortho)	Colorless Liquid	1	2	-	X	X	X	X	X	1	X	X	1	X	-	1	1	-	1	-	-
Dichlorobenzene (para)	White Crystals	1	2	-	X	X	X	X	X	1	X	X	1	X	-	1	1	-	1	-	-
Dichlorobenzyl Chloride	Colorless Liquid	1	2	-	X	X	X	X	X	1	X	X	-	X	-	-	-	-	-	-	-
Dichlorodifluoromethane (Freon 12)	Gas, Liquid @ 140 PSIG @ 100°F	SPECIAL HOSE REQUIRED														-	-	-	-	-	-
Dichloroethane (Ethylene Dichloride)	Colorless Oily Liquid	1	2	2	X	X	X	X	X	2	X	X	X	X	-	-	-	-	-	-	-
Dichloroethyl Ether	Colorless Liquid	1	-	-	-	X	-	X	-	X	-	X	-	-	-	-	-	-	-	-	-
Dichloroethylene	Colorless Liquid	1	2	X	X	X	X	X	X	1	X	-	-	-	-	-	-	-	-	-	X
Dichloroethylene (Acetylene Dichloride)	Colorless Liquid	1	X	X	X	-	X	X	-	X	1	-	X	1	X	-	-	-	-	-	X
Dichloromethane (Methylene Chloride)	Colorless Liquid	1	1	2	X	X	X	X	X	2	X	X	X	X	1	1	1	-	1	-	-
Dichloropentane	Light Yellow Liquid	1	-	-	X	X	X	X	X	X	1	X	-	-	-	-	-	-	-	-	-
Dichloropropane (Propylene Dichloride)	Colorless Liquid	1	-	-	X	X	X	X	X	2	X	-	-	-	-	-	-	-	-	-	-
Dicyclohexylamine	Colorless Liquid	1	-	-	X	-	X	X	X	X	X	X	-	-	-	-	-	-	-	-	-
DIDA [Diisodecyl Adipate]	Light Colored Oily Liquid	1	-	-	-	X	-	X	-	1	X	X	-	-	-	-	-	-	-	-	-
Diesel Fuel	Liquid	1	1	1	X	1	X	X	2	X	-	X	-	1	-	1	1	1	1	1	2
Diethanolamine (20%)	In Water or Alcohol	1	-	-	2	2	2	2	X	1	-	2	1	-	2	1	1	1	1	X	-
Diethanolamine	Liquid above 83°F (29°C)	1	-	-	-	-	-	-	-	-	-	-	-	-	-	-	-	-	-	-	X
Diethyl Ether (Ethyl Ether)	Colorless Liquid	1	2	-	X	X	X	X	X	2	X	X	1	-	2	2	1	1	1	1	1
Diethyl Ketone	Colorless Liquid	1	-	-	2	X	-	X	X	2	X	X	-	-	X	-	-	-	-	-	-
Diethyl Oxalate	Colorless Oily Liquid	1	-	-	X	X	-	X	X	X	-	X	-	-	X	-	-	-	-	-	-
Diethyl Phthalate (Ethyl Phthalate)	Water White Liquid	1	1	-	-	X	X	X	-	2	-	-	2	-	-	-	1	1	-	1	-

CHEMICAL RESISTANCE TABLE

THE WORLD OF HOSE

Chemical	Form (at room temperature unless otherwise stated)	Gates Hose / Polymers														Couplings / Adapters					
		Teflon®	XLPE	UHMWPE	EPDM	NBR	SBR	NR	CR	Butyl	Fluorocarbon	Hypalon®	CPE	Nylon	PVC	Iron/Carbon Steel	Stainless Steel 304	Stainless Steel 316	Aluminum	Brass	Polypro
Diethyl Sebacate	-	1	1	-	-	X	X	X	X	2	2	X	2	-	-	-	1	1	-	1	-
Diethyl Sulfate	Colorless Liquid	1	-	-	1	X	1	X	1	2	X	X	-	-	-	-	-	-	-	-	-
Diethyl Sulfide (Ethyl Sulfide)	Colorless Oily Liquid	1	1	-	-	-	-	-	-	-	1	-	-	-	-	-	-	-	-	-	-
Diethylacetaldehyde (Ethylbutyraldehyde)	Colorless Liquid	1	1	-	-	-	-	-	-	-	-	-	-	-	-	-	-	-	-	-	-
Diethylamine	Colorless Liquid	-	-	2	-	-	-	-	-	-	-	-	-	-	-	-	1	1	-	1	1
Diethylbenzene	Colorless Liquid	1	1	-	X	-	X	X	-	X	1	-	2	-	-	-	-	-	-	-	-
Diethylene Dioxide (1,4 Dioxane)	Colorless Liquid	1	1	-	2	X	X	X	X	2	X	X	2	1	X	1	1	1	1	1	1
Diethylene Ether (Dioxane)	Colorless Liquid	1	1	-	2	X	X	X	X	2	X	X	2	1	X	1	1	1	1	1	1
Diethylene Glycol (Dihydroxydiethyl Ether)	Colorless Syrupy Liquid	1	1	-	1	1	1	1	1	1	1	-	1	1	1	1	1	1	1	1	1
Diethylene Glycol Methyl Ether (Methyl Cellosolve)	Colorless Liquid	1	1	-	1	-	X	X	-	X	1	X	1	-	-	-	-	-	-	-	-
Diethylene Glycol Monobutyl Ether	Colorless Liquid	1	1	-	1	-	-	-	-	-	1	-	-	-	-	-	-	-	-	-	-
Diethylene Glycol Monobutyl Ether Acetate	Colorless Liquid	1	1	-	1	-	-	-	-	-	-	-	-	-	-	-	-	-	-	-	-
Diethylene Glycol Monoethyl Ether	Colorless Liquid	1	1	-	1	-	-	-	-	-	1	-	-	-	-	-	-	-	-	-	-
Diethylene Glycol Monomethyl Ether	Colorless Liquid	1	1	-	1	-	-	-	-	-	1	-	-	-	-	-	-	-	-	-	-
Diethylene Glycol Monomethyl Ether Acetate	Colorless Liquid	1	1	-	1	-	-	-	-	-	-	-	-	-	-	-	-	-	-	-	-
Diethylenetriamine	Yellow Liquid	1	1	1	1	-	X	-	X	1	X	X	-	-	-	-	-	-	-	-	-
Dihydroxyacetone	In Water	1	1	-	1	-	-	-	-	-	-	-	-	-	-	-	-	-	-	-	-
Dihydroxydiethyl ether (Diethylene glycol)	Colorless Syrupy Liquid	1	1	1	1	1	1	1	1	1	1	-	1	1	1	1	1	1	1	1	1
Diisobutyl Ketone	Colorless Liquid	1	1	-	1	X	X	X	X	2	X	X	2	1	-	-	1	1	-	1	1
Diisobutyl Phenol (Octyl Phenol)	White Flakes	1	-	-	-	-	-	1	-	-	-	-	-	-	-	-	-	-	-	-	-
Diisobutyl Phthalate	Liquid	1	1	-	-	-	-	-	-	-	-	-	-	-	-	-	-	-	-	-	-
Diisobutyrene	Colorless Liquids	1	1	-	X	2	X	X	X	X	1	X	1	-	-	-	1	1	-	1	-
Diisodecyl Adipate (DIDA)	Light Colored Oily Liquid	1	-	-	-	X	-	X	-	1	X	X	-	-	-	-	-	-	-	-	-
Diisooctyl Phthalate (DIOP)	Nearly Colorless Liquid	1	-	-	1	X	-	X	-	1	X	X	-	-	-	-	-	-	-	-	-
Diisopropanolamine	Liquid above 108°F (42°C)	1	-	-	-	2	-	2	-	1	-	-	-	-	-	-	-	-	-	-	-
Diisopropyl Ketone	Colorless Liquid	1	1	-	1	X	X	X	X	2	X	X	-	1	-	-	1	1	-	1	-
Diisopropylamine	Colorless Liquid	1	1	-	-	-	-	-	-	-	-	-	-	-	-	-	-	-	-	-	-
Diisopropylbenzene (meta)	Colorless Liquid	1	2	2	X	-	-	-	-	-	1	-	-	-	-	-	-	-	-	-	-
Diisopropylidene Acetone (Phorone)	Yellow Liquid	1	1	-	2	X	X	X	X	2	X	X	-	-	-	1	1	1	-	1	-
Dilauryl Ether	Liquid above 92°F (33°C)	1	1	-	1	-	-	-	-	-	X	-	-	-	-	-	-	-	-	-	-
Dimethyl Acetamide (DMAC)	Colorless Liquid	1	1	-	-	-	-	-	-	-	-	-	-	-	-	-	-	-	-	-	-
Dimethyl Aniline	Yellow/brown Oily Liquid	1	1	-	X	X	X	X	X	2	1	X	2	-	-	-	-	-	-	1	-
Dimethyl Ether	Liquid under Pressure	1	1	1	1	X	X	X	X	2	X	X	-	-	-	1	1	1	1	1	-
Dimethyl Formamide	Water White Liquid	1	1	-	2	-	-	-	-	X	-	-	-	-	-	1	1	1	-	-	1
Dimethyl Phthalate	Colorless Oily Liquid	1	1	-	2	X	X	X	X	2	1	X	1	-	-	-	-	-	-	1	-
Dimethyl Sulfate (Methyl Sulfate)	Colorless Liquid	1	1	-	X	X	X	X	X	2	X	X	-	1	1	-	-	-	-	-	-
Dimethyl Sulfide	Colorless Liquid	1	1	-	-	-	-	-	-	-	1	-	-	-	-	-	-	-	-	-	-
Dimethyl Sulfoxide	Colorless Liquid	1	1	-	-	-	-	-	-	-	1	-	-	-	-	-	-	-	-	-	-
Dimethyl Terephthalate	Colorless Crystals	-	-	-	-	X	X	-	X	X	1	-	-	-	-	-	-	-	-	-	-
Dimethylamine (DMA)	Liquid @ 70 PSIG @ 120°F (49°C)	1	1	1	-	-	-	-	-	-	-	-	-	-	-	-	-	-	-	-	-
Dimethylaminoethanol (Dimethylethanolamine)	Colorless Liquid	1	1	-	2	-	-	-	-	-	-	-	-	-	-	-	-	-	-	-	-
Dimethylaminomethyl Phenol (DMP)	Dark Red Liquid	1	1	-	-	-	-	-	-	-	1	-	-	-	-	-	-	-	-	-	-
Dimethylbenzene (DMB)	Colorless Liquid	1	X	X	X	X	X	X	X	1	X	X	X	X	-	-	-	-	-	-	-
Dimethylcarbinol (isopropyl alcohol)	Colorless Liquid	1	1	1	1	1	2	2	2	1	1	2	1	1	2	1	1	1	1	2	1
Dimethylcyclohexylamine	Water White Liquid	1	1	-	-	-	-	-	-	-	-	-	-	-	-	-	-	-	-	-	-
Dimethylformamide (DMF)	Water white Liquid	1	2	-	-	-	-	-	-	X	-	-	-	-	-	1	1	1	-	-	1
Dimethylketone (Acetone)	Colorless Liquid	1	1	X	2	X	X	X	X	2	X	X	1	1	X	1	1	1	1	1	2
Dimethylphenol (Xylenol)	White solid, liquid @ 68°F (20°C)	1	1	-	-	-	-	-	-	-	1	-	-	-	-	-	-	-	-	-	-
Dinitrobenzene (Soluble in Chloroform)	In Chloroform	1	2	-	X	-	-	-	-	-	1	-	-	-	-	-	-	-	-	-	-
Dinitrogen Tetroxide (Nitrogen Dioxide)	Liquid @ 50 PSIG @ 120°F (49°C)	1	-	-	-	-	-	-	-	-	1	-	-	-	-	-	-	-	-	-	-
Dinitrotoluene, Solid	In Alcohol or Ether	1	1	1	1	-	-	-	-	-	X	-	-	-	-	-	-	-	-	-	-
Diocetyl Adipate di (2-ethylhexyl) adipate	Light Colored Oily Liquid	1	1	-	-	-	-	-	-	-	1	-	-	-	-	-	-	-	-	-	-

Chemical	Form (at room temperature unless otherwise stated)	Gates Hose / Polymers													Couplings / Adapters						
		Teflon®	XLPE	UHMWPE	EPDM	NBR	SBR	NR	CR	Butyl	Fluorocarbon	Hypalon®	CPE	Nylon	PVC	Iron/Carbon Steel	Stainless Steel 304	Stainless Steel 316	Aluminum	Brass	Polypro
Diocetyl Phosphite, di-[2-ethylhexyl] phosphite	Colorless Liquid	1	1	-	X	-	-	-	-	1	-	-	-	X	-	-	-	-	-	-	-
Diocetyl Phthalate, di-[2-ethylhexyl] phthalate	Light Colored Liquid	1	1	-	X	X	X	X	X	X	1	X	2	-	-	1	1	1	1	1	X
Diocetyl Sebacate, di-[2-ethylhexyl] sebacate	Pale Straw Colored Liquid	1	1	-	-	X	X	X	X	2	1	X	X	-	-	-	-	-	-	-	-
Diocetylamine di-[2-ethylhexyl]amine	Water White Liquid	1	-	-	-	-	-	-	-	-	-	-	-	-	-	-	-	-	-	-	-
DIOP (Diisooctyl Phthalate)	Nearly Colorless Liquid	1	-	-	1	X	-	X	-	1	X	X	-	-	-	-	-	-	-	-	-
Dioxane (Diethylene Dioxide)	Colorless Liquid	1	1	-	2	X	X	X	X	2	X	X	2	1	X	1	1	1	1	1	1
Dioxane (Diethylene Ether)	Colorless Liquid	1	1	-	2	X	X	X	X	2	X	X	2	1	X	1	1	1	1	1	1
Dioxolane (Ethylene Glycol Formal)	Water White Liquid	1	-	-	-	-	-	-	-	-	X	-	-	-	-	1	1	1	1	1	-
Dipentene (Cinene, Limonene)	Colorless Liquid	1	2	-	X	X	X	X	X	-	1	-	-	1	-	1	1	1	1	1	-
Diphenyl Phthalate	Yellow White Powder	1	1	-	-	-	-	-	-	-	1	-	-	-	-	-	-	-	-	-	-
Dipropyl Ketone	Colorless Liquid	1	1	-	1	-	-	-	-	-	X	-	-	-	-	-	-	-	-	-	-
Dipropylamine	Water White Liquid	1	1	-	-	-	-	-	-	-	-	-	-	-	-	-	-	-	-	-	-
Dipropylene Glycol	Colorless Liquid	1	1	1	1	-	-	-	-	-	1	-	-	-	-	-	-	-	-	-	-
Dipropylene Glycol Monomethyl Ether (DPM)	Colorless Liquid	1	1	1	1	-	-	-	-	-	-	-	-	-	-	-	-	-	-	-	-
Dirco Oils	Liquid	1	1	-	X	1	-	-	-	X	-	-	-	1	-	1	1	1	1	1	-
Disodium Phosphate (DSP soluble in H2O)	Colorless or White Powder	-	-	-	-	-	-	-	-	-	-	-	-	-	-	-	-	-	-	-	-
Disodium Phosphate Solution	In Water	1	1	1	1	-	-	-	-	-	1	-	-	-	-	-	-	-	-	-	-
Distillate Fuel Oil	Clear to Brown Liquid	1	2	-	X	-	-	-	-	-	1	-	-	-	-	-	-	-	-	-	-
Divinylbenzene (20-25% or 50-60% Grades)	Water White to Straw Liquid	1	2	-	X	X	X	X	X	-	X	1	-	-	-	-	-	-	-	-	-
DMA (Dimethylamine)	Gas	1	1	1	-	-	-	-	-	-	-	-	-	-	-	-	-	-	-	-	-
DMAC (Dimethyl Acetamide)	Colorless Liquid	1	1	-	-	-	-	-	-	-	-	-	-	-	-	-	-	-	-	-	-
DMB (Dimethylbenzene)	Colorless Liquid	1	X	X	X	X	X	X	X	X	1	X	X	X	X	-	-	-	-	-	-
DMF (Dimethylformamide)	Water white Liquid	1	2	-	-	-	-	-	-	-	X	-	-	-	1	1	1	-	-	1	-
DMP (Dimethylaminomethyl phenol)	Dark Red Liquid	1	1	-	-	-	-	-	-	-	1	-	-	-	-	-	-	-	-	-	-
Dodecylbenzene (Detergent Alkylate)	Liquid	1	2	-	X	-	-	-	-	-	1	-	-	-	-	-	-	-	-	-	-
Dodecylphenol	Straw Colored Liquid	1	1	-	1	-	-	-	-	-	1	-	-	-	-	-	-	-	-	-	-
Dolomite	Gray, Pink or White Powder	-	-	-	2	1	-	-	-	1	1	1	-	-	-	-	-	-	-	-	-
Dowtherm A (Biphenyl and Biphenyl Ether Mix)	Liquid	1	1	-	1	X	X	X	X	X	1	X	2	-	X	1	1	1	1	1	-
Dowtherm SR-1 (Ethylene Glycol)	Liquid	1	1	1	1	1	-	-	-	-	1	1	-	1	-	2	1	1	1	1	1
DPM (Dipropylene Glycol Monomethyl Ether)	Colorless Liquid	1	1	1	1	-	-	-	-	-	-	-	-	-	-	-	-	-	-	-	-
Duro Oils	Liquid	1	1	-	X	1	-	-	-	X	-	-	-	1	2	1	1	1	1	1	-
E																					
EDB (Ethylene Dibromide)	Colorless Liquid	1	-	-	-	-	-	-	-	-	-	-	-	X	-	-	-	-	-	-	-
EDTA (Ethylenediaminetetraacetic Acid)	Colorless Crystals	1	1	-	1	-	-	-	-	-	1	-	-	-	-	-	-	-	-	-	-
Emulsion (Oil in Water)	Water is Continuous Phase	1	1	1	1	-	-	-	-	-	1	-	-	-	-	-	-	-	-	-	-
Enamels	Liquid	1	1	-	X	-	-	-	-	-	1	-	-	1	2	-	-	-	-	1	-
Epichlorohydrin (Chloropropylene Oxide)	Volatile Liquid	1	2	-	X	-	-	-	-	-	X	-	-	-	1	-	-	-	-	-	1
Epoxy Resin	Solid Pellet	-	-	-	1	-	-	-	-	1	2	X	-	-	-	-	-	-	-	-	-
Essential Oils	Liquid	1	2	-	X	1	X	X	2	-	1	-	-	-	2	1	1	1	1	1	-
Ethanol (Ethyl Alcohol)	Colorless Liquid	1	1	1	1	1	1	1	1	1	1	1	1	1	2	1	1	1	1	2	1
Ethanolamine (Aminoethanol)	Colorless Viscous Liquid	1	2	1	2	2	2	2	2	2	X	X	1	1	2	1	1	1	1	1	-
Ethers	Liquids	1	1	X	1	2	X	X	X	2	X	2	1	-	2	1	1	1	1	1	2
Ethyl Acetate (Acetic Ether)	Colorless Liquid	1	1	X	2	X	X	X	X	2	X	X	2	1	X	1	1	1	1	1	2
Ethyl Acetoacetate	Colorless Liquid	1	1	-	2	X	X	X	X	2	X	X	1	-	-	1	1	1	1	1	X
Ethyl Acrylate	Colorless Liquid	1	2	-	2	X	X	X	X	X	X	X	2	-	X	1	1	1	-	-	X
Ethyl Acrylate, Inhibited	Colorless Liquid	1	2	-	2	X	X	X	X	X	X	X	2	-	X	1	1	1	-	-	X
Ethyl Alcohol (Ethanol)	Colorless Liquid	1	1	1	1	1	1	1	1	1	1	1	1	1	2	1	1	1	1	2	1
Ethyl Aluminum Dichloride 90°F (32°C)	Clear Yellow Liquid	1	-	-	-	X	-	X	-	X	2	X	-	-	-	-	-	-	-	-	-
Ethyl Bromide	Colorless Liquid	1	2	-	X	X	X	X	X	X	1	X	2	1	X	-	1	1	-	1	-
Ethyl Butyl Ether (Butyl Ethyl Ether)	Liquid	1	-	-	-	2	-	X	-	X	-	2	-	-	-	-	-	-	-	-	-
Ethyl Butyrate	Colorless Liquid	1	1	-	-	X	X	X	X	2	-	-	-	-	-	-	1	1	1	-	-
Ethyl Chloride	Compressed Liquid	1	2	2	X	X	X	X	X	X	1	X	-	-	X	2	1	1	1	2	X

CHEMICAL RESISTANCE TABLE

THE WORLD OF HOSE

Chemical	Form (at room temperature unless otherwise stated)	Gates Hose / Polymers													Couplings / Adapters						
		Teflon®	XLPE	UHMWPE	EPDM	NBR	SBR	NR	CR	Butyl	Fluorocarbon	Hypalon®	CPE	Nylon	PVC	Iron/Carbon Steel	Stainless Steel 304	Stainless Steel 316	Aluminum	Brass	Polypro
Ethyl Chloroformate (Ethyl Chlorocarbonate)	Water White Liquid	1	-	-	X	X	-	-	-	-	1	-	-	-	-	-	-	-	-	-	-
Ethyl Ether (Diethyl Ether)	Colorless Liquid	1	2	X	X	X	X	X	X	X	2	X	1	2	X	2	1	1	1	1	1
Ethyl Ether Acetate (Cellosolve Acetate)	Colorless Liquid	1	1	-	2	X	-	-	-	-	X	-	1	-	1	1	1	1	-	-	1
Ethyl Formate	Water White Liquid	1	-	-	2	X	-	-	-	-	1	-	-	-	-	-	-	-	-	-	-
Ethyl Iodide	Colorless Liquid	1	-	-	X	X	-	X	X	X	2	X	-	-	-	-	-	-	-	-	-
Ethyl Isobutyrate	Colorless Liquid	1	-	-	X	X	-	X	X	X	-	-	-	-	-	-	-	-	-	-	-
Ethyl Mercaptan (Ethanethiol)	Colorless Pungent Liquid	1	1	-	X	X	X	X	X	X	1	X	-	-	X	2	-	-	-	-	-
Ethyl Methyl Ketone (MEK)	Colorless Liquid	1	1	1	2	X	-	-	X	-	X	X	2	1	X	-	-	-	-	-	-
Ethyl Oleate	Light Yellowish Liquid	1	-	-	-	-	-	-	-	-	-	-	-	-	-	-	-	-	-	-	-
Ethyl Oxalate	Colorless Liquid	1	1	-	2	X	2	2	X	2	1	-	1	-	-	-	-	-	-	-	-
Ethyl Pentachlorobenzene	-	1	1	-	X	X	X	X	X	X	1	X	-	-	-	2	1	1	-	1	-
Ethyl Phthalate (Diethyl phthalate)	Water White Liquid	1	1	-	-	X	X	X	-	2	-	-	2	-	-	-	1	1	-	1	-
Ethyl Propionate	Water White Liquid	1	-	-	X	X	-	X	X	X	-	-	-	-	-	-	-	-	-	-	-
Ethyl Propyl Ketone (3-Hexanone)	Colorless Liquid	1	-	-	-	X	-	X	-	2	X	X	-	-	-	-	-	-	-	-	-
Ethyl Silicate	Colorless Liquid	1	1	-	2	1	2	2	1	-	1	-	1	-	-	1	1	1	1	1	1
Ethyl Sulfide (Diethyl Sulfide)	Colorless Oily Liquid	1	1	-	-	-	-	-	-	-	1	-	-	-	-	-	-	-	-	-	-
Ethylamine	Colorless Liquid or Gas	1	2	-	1	X	X	X	X	2	X	X	1	-	-	-	1	1	-	1	-
Ethylbenzene	Colorless Liquid	1	2	-	X	X	X	X	X	X	1	X	2	-	-	1	1	1	-	1	-
Ethylbutanol (2-Ethylbutyl Alcohol)	Colorless Liquid	1	1	1	1	1	-	-	1	1	1	2	1	1	1	-	-	-	-	-	-
Ethylbutyl Alcohol (Ethylbutanol)	Colorless Liquid	1	1	1	1	1	-	-	1	1	1	2	1	1	1	-	-	-	-	-	-
Ethylbutyl Amine	Water White Liquid	1	1	-	-	-	-	-	-	-	-	-	-	-	-	-	-	-	-	-	-
Ethylbutyl Ketone	Clear Liquid	1	1	-	1	-	-	-	-	-	X	-	-	-	-	-	-	-	-	-	-
Ethylbutylaldehyde (Diethylacetaldehyde)	Colorless Liquid	1	1	-	-	-	-	-	-	-	-	-	-	-	-	-	-	-	-	-	-
Ethylcellulose	Granular Solid	1	1	-	-	-	-	1	-	-	-	1	-	-	1	1	1	-	1	-	-
Ethylene Chlorohydrin	Colorless Liquid	1	1	-	X	X	-	-	X	2	1	-	-	X	X	-	-	-	-	-	-
Ethylene Cyanohydrin	Straw Colored Liquid	1	-	-	-	-	-	-	-	-	-	-	-	-	-	-	-	-	-	-	-
Ethylene Dibromide (EDB)	Colorless Liquid	1	-	-	-	-	-	-	-	-	-	-	-	-	X	-	-	-	-	-	-
Ethylene Dichloride (Chloroethane)	Colorless Liquid	1	2	2	X	X	X	X	X	X	2	X	X	X	X	-	-	-	-	-	-
Ethylene Glycol	Colorless Liquid	1	1	1	1	1	-	-	1	1	1	2	1	-	1	2	1	1	1	1	1
Ethylene Glycol Formal (Dioxolane)	Water White Liquid	1	-	-	-	-	-	-	-	-	X	-	-	-	-	1	1	1	1	1	-
Ethylene Glycol Monoethylether	Colorless Liquid	1	1	-	1	X	-	-	-	-	-	-	-	-	-	-	-	-	-	-	-
Ethylene Glycol Monoethylether Acetate	Colorless Liquid	1	1	-	1	X	-	-	-	-	-	-	-	-	-	-	-	-	-	-	-
Ethylene Glycol Monomethyl Ether	Colorless Liquid	1	1	-	2	X	-	-	-	-	-	-	-	-	-	-	-	-	-	-	-
Ethylene Glycol N-Butyl Ether	Colorless Liquid	1	1	-	1	X	-	-	-	-	-	-	-	-	-	-	-	-	-	-	-
Ethylenediamine	Colorless Liquid	1	2	-	2	1	-	-	-	2	X	-	-	-	-	1	1	-	-	-	1
Ethylenediaminetetraacetic acid (EDTA)	Colorless Crystals	1	1	-	1	-	-	-	-	-	1	-	-	-	-	-	-	-	-	-	-
Ethylhexaldehyde	Colorless Liquid	1	1	-	-	-	-	-	-	-	-	-	-	-	-	-	-	-	-	-	-
Ethylhexanediol	Colorless Liquid	1	1	-	2	-	-	-	-	-	-	-	-	-	-	-	-	-	-	-	-
Ethylhexanol (2-ethylhexyl alcohol)	Colorless Liquid	1	1	1	1	1	1	1	1	-	1	1	-	1	1	1	-	-	-	-	-
Ethylhexoic Acid	Liquid	1	1	1	2	-	-	-	-	-	-	-	-	-	-	-	-	-	-	-	-
Ethylhexyl Acetate	Water White Liquid	1	1	-	1	X	-	-	X	-	X	X	-	1	-	-	-	-	-	-	-
Ethylhexyl Acrylate	Liquid	1	2	-	-	X	-	-	-	X	-	-	-	X	-	-	-	-	-	-	-
Ethylhexyl Alcohol (Ethylhexanol)	Colorless Liquid	1	1	1	1	1	1	1	-	1	1	-	1	1	1	-	-	-	-	-	-
F																					
Fatty Acid	Solid, Semisolid or Liquid	1	2	2	2	2	X	X	X	2	2	2	X	2	-	2	2	1	1	1	2
Fatty Alcohol, Blend	C8-11 Liquids, >C11 Solids	1	1	1	1	1	1	1	1	1	1	1	-	1	1	1	-	-	-	-	-
Fatty Petroleum Alcohol	C11 or Less are Liquids	1	1	1	1	1	-	-	-	1	1	-	1	1	-	-	-	-	-	-	-
Ferric Bromide	Red Crystals	-	-	-	-	-	-	1	-	-	-	-	-	-	-	-	-	-	-	-	-
Ferric Chloride	Black-Brown Solid	1	1	-	-	2	-	1	2	1	1	2	1	1	1	X	X	X	X	X	1
Ferric Chloride solution	Liquid	1	1	-	-	2	-	1	2	1	1	2	1	1	1	X	X	X	X	X	1
Ferric Nitrate	Violet Crystals	1	1	-	-	-	2	1	2	2	-	2	1	-	-	X	1	1	-	-	1
Ferric Nitrate Solution	Liquid	1	-	-	1	1	-	1	1	1	1	1	-	1	-	X	1	1	-	-	1

Chemical	Form (at room temperature unless otherwise stated)	Gates Hose / Polymers														Couplings / Adapters					
		Teflon®	XLPE	UHMWPE	EPDM	NBR	SBR	NR	CR	Butyl	Fluorocarbon	Hypalon®	CPE	Nylon	PVC	Iron/Carbon Steel	Stainless Steel 304	Stainless Steel 316	Aluminum	Brass	Polypro
		1 = Preferred - Constant Contact 2 = Acceptable - Intermittent Contact X = Not Recommended - = No Data NOTE: Ratings are for the affect on the polymer only!																			
Ferric Sulfate	Yellow Crystals or Gray Powder	-	-	-	-	-	1	-	-	-	-	-	-	-	X	1	1	X	X	1	
Ferric Sulfate Solution	Liquid	1	1	1	2	2	2	-	2	2	1	2	1	-	1	X	1	1	X	X	1
Ferrous Acetate Solution	Liquid in H2O or Alcohol	1	1	-	-	-	-	-	-	-	1	-	-	-	-	-	-	-	-	-	-
Ferrous Chloride	Greenish-White Crystals	-	-	-	-	-	1	-	-	-	-	-	-	-	X	1	2	-	2	1	
Ferrous Chloride, Solution	Liquid	1	1	-	-	-	-	-	1	1	2	1	-	1	X	1	2	-	2	1	
Ferrous Nitrate	-	1	1	-	2	2	-	-	2	2	-	2	-	-	2	-	1	1	-	-	1
Ferrous Sulfate Solution	Liquid	1	1	1	2	2	2	-	2	2	1	2	1	-	1	X	1	1	X	X	1
Fertilizer (Liquid Manure)	Liquid	1	1	1	1	1	1	1	1	1	1	1	-	1	2	1	1	1	1	1	1
Finishing Oil	Liquid	1	-	1	-	-	-	-	-	-	-	-	-	-	-	-	-	-	-	-	-
Fire-Resistance Hydra-Fluid (Texaco)	Liquid	1	1	-	X	1	-	-	-	X	-	-	-	-	-	1	1	1	1	1	-
Firtec 290, MF	Liquid	1	1	-	-	-	-	-	-	-	-	-	-	-	-	-	-	-	-	-	-
Fish Oil	Liquid	1	-	1	X	1	-	-	2	-	1	-	-	-	-	-	-	-	-	-	-
Fixing Solution (Photo)	Liquid	1	1	-	-	-	2	2	2	2	-	2	-	1	1	-	1	1	-	-	1
Flint	Gray, Brownish, Black	-	-	-	-	-	1	-	-	-	-	-	-	-	-	-	-	-	-	-	-
Floor Wax (Temperature Dependent)	Varies	1	-	1	-	-	-	-	-	-	-	-	-	-	-	-	-	-	-	-	-
Fluoboric Acid (48% Purity)	Colorless Liquid	1	1	1	2	-	2	2	2	-	2	1	-	X	-	1	1	-	-	1	
Fluoboric Acid (up to 48%)	Colorless Liquid	1	1	-	1	-	2	2	2	-	1	2	1	-	X	-	1	1	-	-	1
Fluorine	Pale Yellow Gas	X	-	X	X	-	-	-	-	-	1	-	-	X	1	-	-	-	-	-	-
Fluorine (Liquid)	Yellow Liquid	NO HOSE AVAILABLE														-	-	-	-	-	-
Fluosilicic Acid (50%)	Colorless Liquid	1	1	1	2	X	-	-	2	X	-	2	1	X	X	-	-	-	1	-	1
Formaldehyde	Gas	-	1	-	1	-	-	-	-	-	1	-	-	1	-	X	2	1	2	1	-
Formaldehyde Solution (up to 50%)	Liquid	1	2	1	1	2	X	X	2	2	1	2	1	1	1	X	2	1	2	1	-
Formalin (37-50% HCHO with 15% MeOH)	Liquid	1	1	-	1	2	X	X	2	2	1	2	1	1	1	-	-	-	-	-	-
Formamide	Colorless Oily Liquid	1	1	-	-	-	X	X	-	-	-	-	-	X	-	-	-	-	-	-	-
Formic Acid	Colorless Liquid (bp 100°C)	1	1	1	2	-	X	X	1	2	X	2	1	X	X	X	2	1	-	2	1
FR Fluid D	Liquid	1	1	-	X	1	-	-	-	X	-	-	-	-	-	-	-	-	-	-	-
FR Hydraulic Fluid	Brown Liquid	1	1	-	-	1	-	-	-	-	-	-	-	-	-	-	-	-	-	-	-
Freon 12 (Dichlorodifluoromethane)	Gas or Liquid	SPECIAL HOSE REQUIRED														-	-	-	-	-	-
Freon 13	Gas or Liquid	SPECIAL HOSE REQUIRED														-	-	-	-	-	-
Freon 134a (HFC 134a)	Gas or Liquid	SPECIAL HOSE REQUIRED														-	-	-	-	-	-
Freon 22 (Chlorodifluoromethane)	Gas or Liquid	SPECIAL HOSE REQUIRED														-	-	-	-	-	-
Freon 23	Clear Liquid	SPECIAL HOSE REQUIRED														-	-	-	-	-	-
Fruit Juices	Liquid	-	-	-	-	-	-	-	-	-	-	-	-	1	-	-	-	-	-	-	-
Fuel Oil (ASTM 1-6)	Water White to Brown Liquids	1	2	1	X	1	X	X	2	X	1	X	1	1	X	2	2	2	1	1	-
Fumaric Acid	Colorless Crystals	1	1	1	2	-	2	2	-	-	1	-	-	-	X	-	1	1	-	-	-
Fumaric Acid Solution (Allomalaic Acid)	Liquid	1	1	-	2	1	2	2	-	-	1	-	-	-	X	-	1	1	-	-	-
Furan (Furfuran)	Colorless to Brown Liquid	1	1	1	X	X	X	X	X	X	-	-	1	-	X	1	1	1	1	1	-
Furfural (Ant Oil)	Colorless to Reddish Brown Liquid	1	1	-	X	X	X	X	2	X	2	2	1	-	X	2	1	1	1	1	2
Furfural Alcohol	Colorless to Brown Liquid	1	1	2	X	X	X	X	2	X	1	2	1	1	X	2	1	1	1	1	2
Furfuran (Furan)	Colorless to Brown Liquid	1	1	1	X	X	X	X	X	X	-	-	1	-	X	1	1	1	1	1	-
Furfuryl Alcohol	Colorless to Reddish Brown Liquid	1	1	-	-	-	-	-	-	-	1	-	-	1	-	-	-	-	-	-	-
Fusel Oil (Amyl Alcohol, Grain Oil)	Colorless Liquid	1	1	1	2	2	2	2	2	2	1	2	1	1	1	1	1	1	1	1	-
Fyrguard 150, 200	-	1	1	-	1	1	-	-	-	1	-	-	-	-	-	1	1	1	1	1	-
Fyrquel 15R&O, 220R&O, 550R&O	-	1	1	-	1	X	-	-	-	1	-	-	-	-	-	1	-	-	1	-	-
Fyrquel 90, 150, 220, 300, 550, 1000	-	1	1	-	1	X	-	-	-	1	-	-	-	-	-	1	-	-	1	-	-
G																					
Gallic Acid (3,4,5 Trihydroxybenzoic Acid)	In Alcohol or Glycerol	1	1	1	1	X	2	2	X	2	1	-	1	X	X	X	1	1	-	-	1
Gallic Acid Solution	In Alcohol Solution	1	1	-	-	X	2	2	X	2	1	-	1	X	X	X	1	1	-	-	1
Gasohol (Gasoline blended with Ethanol)¹	Colorless Liquid	1	2	1	X	2	X	X	2	X	1	X	-	1	X	2	1	1	1	1	X
Gasoline (Oxygenated - Blended With MTBE)¹	Colorless Liquid	1	2	1	X	2	X	X	2	X	1	X	-	1	X	2	1	1	1	1	X
Gasoline (Unleaded Up to 50% Aromatics)¹	Colorless Liquid	1	2	1	X	2	X	X	2	X	1	X	1	1	X	2	1	1	1	1	-
Gasoline (White)¹	Colorless Liquid	1	2	-	X	2	X	X	2	X	1	X	-	1	X	2	1	1	1	1	-

CHEMICAL RESISTANCE TABLE

THE WORLD OF HOSE

Chemical	Form (at room temperature unless otherwise stated)	Gates Hose / Polymers													Couplings / Adapters						
		Teflon®	XLPE	UHMWPE	EPDM	NBR	SBR	NR	CR	Butyl	Fluorocarbon	Hypalon®	CPE	Nylon	PVC	Iron/Carbon Steel	Stainless Steel 304	Stainless Steel 316	Aluminum	Brass	Polypro
Gelatin	Flakes or Powder	-	-	-	-	-	-	1	-	-	-	-	1	1	-	-	-	-	-	-	-
Glacial Acetic Acid	Clear Colorless Liquid	1	1	1	2	-	-	-	X	X	X	-	X	X	X	-	-	-	-	-	-
Glacial Methacrylic Acid (GMAA)	White Crystals	1	-	-	-	-	-	-	-	-	-	-	-	-	-	-	-	-	-	-	-
Glauber's Salt (Sodium Sulfate Decahydrate)	Crystals or Powder	1	-	-	1	-	1	1	-	-	-	-	-	-	-	-	-	-	-	-	-
Gluconic Acid (Commercial 50% Aqueous)	Aqueous Solution	1	-	-	-	X	-	X	-	X	-	2	-	-	-	-	-	-	-	-	-
Glucose	Crystals to White Powder	-	-	-	-	-	-	1	-	-	-	-	-	-	1	1	1	1	1	1	-
Glucose Solution	Liquid	1	1	-	1	1	1	1	1	1	1	1	-	-	1	1	1	1	1	1	-
Glue	Varies	1	1	-	X	2	X	X	2	X	1	1	-	2	1	2	1	1	1	X	-
Glycerine (Glycerol)	Clear Viscous Liquid	1	1	-	1	1	1	1	1	1	1	1	1	1	-	1	2	1	1	1	-
Glycerol (Glycerine)	Clear Viscous Liquid	1	1	-	1	1	1	1	1	1	1	1	1	-	1	2	1	1	1	1	-
Glycerol Monolaurate	Liquid above 80°F (27°C)	1	1	1	1	-	-	-	-	1	1	-	-	-	-	-	-	-	-	-	-
Glycol FR Fluids	Liquid	1	-	-	1	1	-	-	-	1	-	-	-	-	-	-	-	-	-	-	-
Glycol Slurry	Watery suspension	1	-	2	-	-	-	-	-	-	-	-	-	-	-	-	-	-	-	-	-
Glycols (ie Ethylene Glycol)	Clear Colorless Liquid	1	1	1	1	1	1	1	1	1	1	1	1	1	-	1	1	1	1	1	-
GMAA (Glacial Methacrylic Acid)	White Crystals	1	-	-	-	-	-	-	-	-	-	-	-	-	-	-	-	-	-	-	-
Graphite	Powdered, Flake, Crystals	1	-	1	-	-	-	1	-	-	-	-	-	-	-	-	-	-	-	-	-
Grease	Semi-Solid	1	1	2	X	1	X	X	2	X	1	2	-	-	1	1	1	1	1	1	-
Grease, Silicone Base	-	1	-	1	-	-	-	-	-	-	-	-	-	1	-	1	1	1	1	1	-
Green Liquor (Effluent Alkaline Pulping)	Liquid	1	1	1	-	-	-	-	-	-	-	-	-	1	-	-	-	-	-	-	-
Green Sulfate Liquor	Liquid	1	1	1	1	2	1	1	1	1	-	1	2	-	-	1	1	1	-	-	-
H																					
Halowax (Chlorinated Hydrocarbons)	Oils to Waxy Solid	1	1	1	X	X	X	X	X	X	1	X	-	-	-	-	-	-	-	-	-
HEA (2-Hydroxyethyl Acrylate)	Liquid	1	1	1	X	-	-	-	-	-	1	1	-	-	-	-	-	-	-	-	-
HEA Acid (2-Hydroxyethyl Acrylate)	Liquid	1	1	1	X	-	-	-	-	-	1	-	1	-	-	-	-	-	-	-	-
Hematite (Iron Ore)	Black to Brick Red	1	-	-	-	-	-	1	-	-	-	-	-	-	-	-	-	-	-	-	-
HEP (2-Hydroxypropyl Acrylate)	Liquid	1	1	1	X	-	-	-	-	-	1	-	1	-	-	-	-	-	-	-	-
Heptachlor (In Xylene)	Liquid	1	2	-	X	2	X	X	X	X	1	-	-	1	X	-	-	-	-	-	-
Heptanal (Heptaldehyde)	Colorless Oily Liquid	1	-	-	-	-	-	-	-	-	-	-	-	-	-	-	-	-	-	-	-
Heptane	Colorless Liquid	1	2	1	X	1	X	X	2	X	1	X	1	1	2	1	1	1	1	1	-
Heptanedicarboxylic Acid (Azelaic Acid)	Yellowish to White Powder	1	-	-	-	-	-	1	-	-	-	-	-	-	-	-	-	-	-	-	-
Heptanoic Acid	Clear Oily Liquid	1	1	1	-	-	-	-	-	-	1	-	-	-	-	-	-	-	-	-	-
Heptanol	Colorless Liquid	1	1	1	1	1	1	1	1	1	1	1	1	1	1	1	-	-	-	-	-
Hexachlorocyclohexane	White to Yellowish Flakes	-	-	-	-	-	-	1	-	-	-	-	-	-	-	-	-	-	-	-	-
Hexachlorocyclopentadiene	Yellow Liquid	1	-	-	X	-	X	X	-	X	1	-	-	-	-	-	-	-	-	-	-
Hexadecanoic Acid (Palmitic Acid)	White Crystals	-	-	-	-	-	-	1	-	-	-	-	-	-	-	-	-	-	-	-	-
Hexahydrophthalic Anhydride	Clear Colorless Viscous Liquid	1	-	-	-	-	-	-	-	-	-	-	-	-	-	-	-	-	-	-	-
Hexaldehyde	Colorless Liquid	1	1	1	1	-	-	-	-	-	-	-	-	-	-	1	1	1	1	1	-
Hexamethylenediamine, Solution	Colorless Flat Solid Leaflets	-	-	-	-	-	-	1	-	-	-	-	-	-	-	-	-	-	-	-	-
Hexamethylenimine	Clear Colorless Liquid	1	-	-	-	-	-	-	-	-	-	-	-	-	-	-	-	-	-	-	-
Hexane	Colorless Liquid	1	X	1	X	1	X	X	-	X	1	-	1	1	X	1	1	1	-	1	-
Hexanol (Hexyl Alcohol)	Colorless Liquid	1	1	-	X	1	-	-	2	-	1	X	1	-	-	1	1	1	1	2	-
Hexanone (Ethyl Propyl Ketone)	Colorless Liquid	1	-	-	X	-	X	-	X	-	2	X	X	-	-	-	-	-	-	-	-
Hexene	Colorless Liquid	1	-	-	X	2	X	X	-	X	1	-	1	-	-	1	1	1	-	1	-
Hexyl "Cellosolve" (EG monoethyl ether)	Water White Liquid	1	1	1	-	-	-	-	-	-	1	-	-	-	-	-	-	-	-	-	-
Hexyl Alcohol (Hexanol)	Colorless Liquid	1	1	-	X	1	-	-	2	-	1	X	1	-	-	1	1	1	1	2	-
Hexyl Methacrylate	Liquid	1	-	-	-	-	-	-	-	-	-	-	-	-	-	-	-	-	-	-	-
Hexylamine	Water White Liquid	1	-	-	-	X	-	X	-	2	X	X	-	-	-	-	-	-	-	-	-
Hexylene (1-Hexene)	Colorless Liquid	1	-	-	X	2	X	X	-	X	1	-	1	-	-	1	1	1	-	1	-
Hexylene Glycol	Colorless Liquid	1	1	1	1	-	-	-	-	-	1	-	-	-	-	-	-	-	-	-	-
Honey	Yellow Liquid	1	-	-	1	1	-	1	1	-	1	-	-	-	1	-	-	-	-	-	-
Houghto-Safe 1055, 1110, 1115, 1120, 1130	Liquid	1	1	-	1	X	-	-	-	1	-	-	-	-	-	1	1	1	1	1	-
Houghto-Safe 271, 416, 520 & 616, 620	Liquid	1	1	-	1	1	-	-	-	1	-	-	-	-	-	1	1	1	1	1	-

Chemical	Form (at room temperature unless otherwise stated)	Gates Hose / Polymers														Couplings / Adapters					
		Teflon®	XLPE	UHMWPE	EPDM	NBR	SBR	NR	CR	Butyl	Fluorocarbon	Hypalon®	CPE	Nylon	PVC	Iron/Carbon Steel	Stainless Steel 304	Stainless Steel 316	Aluminum	Brass	Polypro
		1 = Preferred - Constant Contact 2 = Acceptable - Intermittent Contact X = Not Recommended - = No Data NOTE: Ratings are for the affect on the polymer only!																			
Houghto-Safe 5046	Liquid	1	1	-	X	1	-	-	-	X	-	-	-	-	-	1	1	1	1	1	-
Houghto-Safe 625, 640 & 525 Under 100°F [38°C]	Liquid	1	1	-	1	1	-	-	-	1	-	-	-	-	-	1	1	1	1	1	-
HPA Acid [2-Hydroxypropyl Acrylate]	Liquid	1	1	1	X	-	-	-	-	-	1	-	1	-	-	-	-	-	-	-	-
HPO [Sodium Thiosulfate]	White Powder	1	1	-	-	1	1	1	1	1	-	1	1	1	1	X	1	1	2	X	-
Hy-Chock Oil	Liquid	1	1	-	-	1	-	-	-	-	1	-	-	1	-	1	1	1	-	-	-
Hydrocyanic Acid (up to 98%)	Water White Liquid	1	1	-	-	-	-	-	-	-	1	-	-	-	-	X	1	1	1	X	-
Hydrafluid 760 [Texaco and Houghton]	Liquid	1	1	-	X	1	-	-	-	X	1	-	-	1	-	1	1	1	1	1	-
Hydrafluid AZR&O, A, B, AA, C	Liquid	1	1	-	X	1	-	-	-	X	1	-	-	1	-	1	1	1	1	-	-
Hydrasol A [Textile Dying]	-	1	1	-	X	1	-	-	-	X	1	-	-	1	-	1	1	1	1	-	-
Hydraulic Fluid (Phosphate Ester Base)	Liquid	1	1	-	1	X	-	-	X	1	1	-	-	1	1	1	1	1	-	-	-
Hydraulic Fluid (Polyalphaolefin)	Liquid	1	-	-	-	-	-	-	-	-	1	-	-	-	-	1	1	1	1	1	-
Hydraulic Fluid [Std. Petroleum Oils]	Liquid	1	1	-	X	1	X	X	2	X	1	2	1	1	1	1	1	1	1	1	-
Hydraulic Fluid (Water Glycol Base)	Liquid	1	1	-	-	1	2	2	1	1	1	-	-	1	1	1	1	1	1	1	-
Hydraulic Fluid HF-18, HF-20	Liquid	1	1	-	1	1	-	-	-	1	1	-	-	1	2	1	1	1	1	1	-
Hydraulic Fluid HF-31	Liquid	1	1	-	X	-	-	-	-	X	-	-	-	1	-	1	1	1	1	1	-
Hydrazine	Colorless Fuming Liquid	1	1	-	2	X	X	X	X	2	X	X	-	-	X	-	-	-	-	-	-
Hydrazine Hydrate	Colorless Fuming Liquid	1	1	-	2	X	X	X	X	2	X	X	-	-	X	-	-	-	-	-	-
Hydrazine Solution	Liquid	1	1	-	2	X	X	X	X	2	X	X	-	-	X	-	-	-	-	-	-
Hydro-Drive Oil [Houghton]	Liquid	1	-	-	X	1	-	-	-	X	-	-	-	-	2	-	-	-	-	-	-
Hydrobromic Acid (62% and less)	Colorless to Yellow Liquid	1	1	1	X	X	2	2	X	2	1	2	1	X	X	-	-	X	-	-	-
Hydrobromic Acid (to 48%)	Colorless to Yellow Liquid	1	1	1	1	X	2	2	X	2	1	2	1	X	X	-	-	X	-	-	-
Hydrochloric Acid (15%)	Colorless to Yellow Liquid	1	1	1	2	X	2	2	X	2	1	2	1	X	X	X	X	X	X	X	-
Hydrochloric Acid (37%)	Colorless to Yellow Liquid	1	1	1	X	X	2	2	X	2	1	2	1	X	X	X	X	X	X	X	-
Hydrochloric Acid, anhydrous	Colorless Fuming Gas	1	-	-	-	-	-	-	-	-	1	-	-	-	-	X	X	X	X	X	-
Hydrocyanic Acid (10% Solution with water)	Water White Liquid	1	1	1	-	X	2	2	X	-	1	2	-	-	X	X	1	1	1	X	-
Hydrocyanic Acid (98% or less)	Water White Liquid below 77°F/25°C	1	-	-	-	-	-	-	-	-	1	-	-	-	X	-	-	-	-	-	-
Hydrocyanic Acid (up to 20%)	Water White Liquid	1	1	-	1	2	2	2	2	-	1	1	-	-	2	-	-	-	-	-	-
Hydrofluoric Acid (38% or less)	Colorless Liquid	1	1	1	2	X	X	X	2	2	1	1	1	X	X	X	X	X	X	X	-
Hydrofluoric Acid (47% or less)	Colorless Liquid	1	1	1	2	X	X	X	2	2	1	2	1	X	X	X	X	X	X	X	-
Hydrofluoric Acid (53 % or less)	Colorless Liquid	1	1	X	-	X	X	X	2	X	1	2	1	X	X	X	X	X	X	X	-
Hydrofluoric Acid (70%)	Colorless Liquid	1	1	X	X	X	X	X	X	-	1	2	-	X	X	X	X	X	X	X	-
Hydrofluoric Acid [Concentrated]	Colorless Liquid	1	1	X	X	X	X	X	X	X	2	2	1	X	X	X	X	X	X	X	-
Hydrofluosilicic Acid	In Water	1	1	1	2	X	X	X	X	X	1	1	X	X	X	X	X	X	-	1	-
Hydrogen [Gas]	Gas	CONTACT DENVER PRODUCT APPLICATION																			
Hydrogen Bromide Liquified [Anhydrous]	Liquid	1	-	-	1	X	X	X	-	X	1	-	-	-	-	-	-	-	-	-	-
Hydrogen Bromide Solution [HydroBromic Acid]	Liquid	1	-	-	-	-	-	-	-	-	-	-	-	-	-	-	-	-	-	-	-
Hydrogen Bromide, Anhydride	Colorless Gas	1	-	-	-	-	-	-	-	-	-	-	-	-	-	-	-	-	-	-	-
Hydrogen Chloride	Colorless Fuming Gas	1	-	-	-	-	-	-	-	-	1	-	1	-	-	-	-	-	-	-	-
Hydrogen Dioxide (Hydrogen Peroxide)	Liquid	1	-	-	2	X	-	-	2	-	1	1	-	-	-	-	-	-	-	-	-
Hydrogen Fluoride	Colorless Gas or Liquid	1	-	-	1	X	X	X	-	2	X	-	-	-	-	1	1	1	-	-	-
Hydrogen Peroxide (35% or less)	Liquid	1	1	1	1	2	X	X	1	X	1	1	1	1	1	X	2	1	1	X	-
Hydrogen Peroxide (50% or less)	Liquid	1	2	1	1	2	X	X	1	X	1	1	1	2	2	X	2	1	1	X	-
Hydrogen Peroxide (70% or less)	Liquid	1	2	1	2	X	X	X	2	-	1	1	1	X	2	X	2	1	1	X	-
Hydrogen Peroxide (90% or less)	Liquid	1	-	1	2	X	X	X	2	-	1	1	-	X	X	X	2	1	1	X	-
Hydrogen Sulfide	Colorless Gas	NO HOSE AVAILABLE																			
Hydrogen Sulfide, Liquified	Liquid @ 410 PSI, 120°F [49°C]	1	-	-	1	X	X	-	2	X	X	-	-	-	-	-	-	-	-	-	-
Hydrolube [Water Glycol]	Liquid	1	-	1	1	-	-	-	2	2	1	-	-	-	1	-	-	-	-	-	-
Hydrolubric Oil [Houghton]	Liquid	1	1	-	X	2	-	-	-	X	-	-	-	1	2	-	-	-	-	-	-
Hydroquinone	White Crystals	1	1	-	X	-	X	X	X	X	2	X	-	-	-	-	1	1	-	-	-
Hydroquinone Solution	Liquid	1	-	-	-	X	X	-	X	X	1	-	-	-	2	-	1	1	-	-	-
Hydroxyacetic Acid	Colorless Crystals	-	-	-	-	-	-	-	1	-	-	-	-	-	-	-	-	-	-	-	-
Hydroxyacetic Acid Solution	Liquid	1	1	1	2	-	-	-	-	-	-	-	-	-	-	-	-	-	-	-	-

CHEMICAL RESISTANCE TABLE

THE WORLD OF HOSE

Chemical	Form (at room temperature unless otherwise stated)	Gates Hose / Polymers														Couplings / Adapters						
		Teflon®	XLPE	UHMWPE	EPDM	NBR	SBR	NR	CR	Butyl	Fluorocarbon	Hypalon®	CPE	Nylon	PVC	Iron/Carbon Steel	Stainless Steel 304	Stainless Steel 316	Aluminum	Brass	Polypro	
Hydroxyethyl Acrylate (HEA)	Liquid	1	1	1	X	-	-	-	-	1	-	1	-	-	-	-	-	-	-	-	-	
Hydroxyethyl Acrylate Acid (HEA Acid)	Liquid	1	1	1	X	-	-	-	-	1	-	1	-	-	-	-	-	-	-	-	-	
Hydroxyethyl Methacrylate	Clear Liquid	1	-	-	-	-	-	-	-	1	-	-	-	-	-	-	-	-	-	-	-	
Hydroxyethyl Methacrylate Solution in Xylene	Clear Liquid	1	2	-	-	-	-	-	-	1	-	-	-	-	-	-	-	-	-	-	-	
Hydroxypropyl Acrylate Acid (HPA Acid)	Liquid	1	1	1	X	-	-	-	-	1	-	1	-	-	-	-	-	-	-	-	-	
Hylene (Toluene Diisocyanate)	Yellow Liquid	1	-	-	2	X	X	X	X	2	X	X	-	-	-	-	-	-	-	-	-	
Hypochlorous Acid (only in dilute solutions)	Greenish-Yellow Aqueous Sol.	1	1	1	2	X	X	X	X	1	2	-	-	-	-	-	-	-	-	-	-	
I																						
Ink (Printers)	Liquid	1	1	-	X	2	X	X	-	X	X	-	-	1	-	2	2	1	-	2	-	
Ink Oil	Liquid	1	2	-	-	2	-	-	-	-	-	-	-	-	-	1	1	1	-	1	-	
Insulating Oil (Transformer)	Liquid	1	1	-	X	1	X	X	2	X	1	X	-	-	-	1	1	1	-	1	-	
Iodine	Grayish Black Granules	1	-	-	-	-	-	1	X	-	-	-	-	-	X	X	X	X	-	-	-	
Iodine Solution	Liquid	1	1	1	1	-	-	-	-	1	-	-	-	-	-	-	-	-	-	-	-	
Iodine, In Alcohol	Liquid	1	1	1	1	-	X	X	2	-	1	-	1	-	1	-	-	-	-	-	-	
Iron Acetate Liquor (Black Liquor)	Black Liquid	1	1	1	2	2	X	X	2	2	1	2	2	-	1	1	1	1	-	-	1	
Iron Hydroxide	Brown precipitate	1	-	-	1	1	-	X	1	1	1	1	-	-	-	-	-	-	-	-	-	
Iron Ore (Hematite)	Black to Brick Red	-	-	-	-	-	-	1	-	-	-	-	-	-	-	-	-	-	-	-	-	
Iron Oxide (Black, Brown, Red or Yellow)	Solid	-	-	-	-	-	-	1	-	-	-	-	-	-	-	-	-	-	-	-	-	
Iron Oxide Slurry	Slurry	-	-	-	-	-	-	1	-	-	-	-	-	-	-	-	-	-	-	-	-	
Iron Salts	-	1	-	-	1	1	-	1	1	1	1	1	-	1	1	-	-	-	-	-	-	
Iron Sulfate Solution (Ferric Sulfate)	Liquid	1	1	1	2	2	2	-	2	2	1	2	1	-	1	X	1	1	X	X	1	
Iron Sulfide Solution (Ferrous Sulfide)	Liquid	1	1	-	-	-	-	-	-	-	1	-	-	-	-	-	-	-	-	-	-	
Isoamyl Acetate	Colorless Liquid	1	-	-	2	X	-	X	X	X	X	X	-	-	-	-	-	-	-	-	-	
Isoamyl Alcohol (Isobutyl Carbinol)	Colorless Liquid	1	-	-	2	2	-	2	2	2	2	2	-	-	-	-	-	-	-	-	-	
Isoamyl Bromide	-	1	-	-	X	X	-	X	X	X	2	X	-	-	-	-	-	-	-	-	-	
Isoamyl Butyrate	Water White Liquid	1	-	-	-	X	-	X	-	X	X	X	-	-	-	-	-	-	-	-	-	
Isoamyl Chloride	Colorless to Yellow Liquid	1	2	-	-	-	-	-	-	1	-	-	-	-	-	-	-	-	-	-	-	
Isoamyl Ether	Colorless Liquid	1	-	-	-	X	-	X	-	X	X	X	-	-	-	-	-	-	-	-	-	
Isoamyl Phthalate	Colorless Liquid	1	-	-	-	X	-	X	-	2	X	X	-	-	-	-	-	-	-	-	-	
Isobutane	Colorless Gas	USE LPG HOSE ONLY														-	-	-	-	-	-	-
Isobutane Liquid	Liquid @ 98 PSIG, 120°F (49°C)	1	-	-	-	-	-	-	-	-	1	-	-	-	-	-	-	-	-	-	-	
Isobutanol (Isobutyl Alcohol)	Colorless Liquid	1	1	1	1	2	2	2	2	2	1	1	1	1	2	1	1	1	1	2	-	
Isobutene (Isobutylene)	Gas	1	-	-	X	1	X	X	-	2	X	-	-	-	-	-	-	-	-	-	-	
Isobutyl Acetate	Colorless Liquid	1	-	-	X	X	-	X	X	X	X	X	-	-	-	-	-	-	-	-	-	
Isobutyl Alcohol (Isobutanol)	Colorless Liquid	1	1	1	1	2	2	2	2	2	1	1	1	1	2	1	1	1	1	2	-	
Isobutyl Aldehyde (Isobutyraldehyde)	Colorless Liquid	1	-	-	2	X	-	X	X	X	X	X	-	-	-	-	-	-	-	-	-	
Isobutyl Carbinol (Primary Isoamyl Alcohol)	Colorless Liquid	1	-	-	2	2	-	2	2	2	2	2	-	-	-	-	-	-	-	-	-	
Isobutylamine	Colorless Liquid	1	-	-	-	X	-	X	-	2	X	X	-	-	-	-	-	-	-	-	-	
Isobutylene (Isobutene)	Gas	1	-	-	X	1	X	X	-	2	X	-	-	-	-	-	-	-	-	-	-	
Isobutylene Liquid (Isobutene Liquid)	Liquid @ 88 PSIG, 120°F (49°C)	1	-	-	-	-	-	-	-	1	-	-	-	-	-	-	-	-	-	-	-	
Isobutyraldehyde (Isobutyl Aldehyde)	Colorless Liquid	1	-	-	2	X	-	X	X	X	X	X	-	-	-	-	-	-	-	-	-	
Isocyanate (Toluene Diisocyanate)	Water White to Yellow Liquid	1	2	-	X	X	X	X	X	X	1	-	-	-	-	1	1	1	-	-	-	
Isocotane	Colorless Liquid	1	2	-	X	1	X	X	1	X	1	1	2	1	X	1	1	1	2	1	-	
Isooctyl Adipate	Viscous Liquid	1	1	-	-	-	-	-	-	1	-	-	-	-	-	-	-	-	-	-	-	
Isooctyl Alcohol	Clear Liquid	1	1	1	1	-	-	-	-	1	-	-	-	-	-	-	-	-	-	-	-	
Isooctyl Thioglycolate	Water White Liquid	1	1	-	2	-	-	-	-	1	-	-	-	-	-	-	-	-	-	-	-	
Isopentane	Colorless Liquid	1	2	-	-	-	-	-	-	1	-	-	-	-	-	-	-	-	-	-	-	
Isophorone	Water White Liquid	1	-	-	-	-	-	-	-	-	-	-	-	-	-	-	-	-	-	-	-	
Isophthaloyl Chloride	Liquid above 106°F (41°C)	1	-	-	-	-	-	-	-	1	-	-	-	-	-	-	-	-	-	-	-	
Isopropanol (Isopropyl Alcohol)	Colorless Liquid	1	1	1	1	1	2	2	2	1	1	2	1	1	2	1	1	1	1	2	1	
Isopropanolamine (MIPA)	Liquid	1	2	-	-	2	-	2	-	1	X	X	-	-	-	-	-	-	-	-	-	
Isopropyl Acetate	Colorless Liquid	1	1	1	2	X	X	X	X	2	-	X	-	1	X	1	1	1	1	1	-	

Chemical	Form (at room temperature unless otherwise stated)	Gates Hose / Polymers														Couplings / Adapters					
		Teflon®	XLPE	UHMWPE	EPDM	NBR	SBR	NR	CR	Butyl	Fluorocarbon	Hypalon®	CPE	Nylon	PVC	Iron/Carbon Steel	Stainless Steel 304	Stainless Steel 316	Aluminum	Brass	Polypro
		1 = Preferred - Constant Contact 2 = Acceptable - Intermittent Contact X = Not Recommended - = No Data NOTE: Ratings are for the affect on the polymer only!																			
Isopropyl Alcohol (Isopropanol)	Colorless Liquid	1	1	1	1	1	2	2	2	1	1	2	1	1	2	1	1	1	1	2	1
Isopropyl Benzene (Cumene)	Colorless Liquid	1	2	-	-	-	-	-	-	-	1	-	2	-	-	-	-	-	-	-	-
Isopropyl Chloride	Colorless Liquid	1	-	-	-	-	-	-	-	-	1	-	-	-	-	-	-	-	-	-	-
Isopropyl Ether	Colorless Liquid	1	1	1	X	X	X	X	X	2	X	X	-	1	X	1	1	1	1	1	-
Isopropylamine	Colorless Liquid	1	1	-	-	-	-	-	-	-	-	-	-	-	-	-	-	-	-	-	-
Isopropylbenzene (Cumene)	Colorless Liquid	1	2	-	-	-	-	-	-	-	1	-	2	-	-	-	-	-	-	-	-
Isopropyltoluene (Cymene)	Colorless Liquid	1	-	-	-	-	-	-	-	-	1	-	-	1	-	1	1	1	1	1	-
J																					
Jet Fuel A and A1 ²	Liquid	1	-	-	-	1	-	-	-	-	1	-	-	-	-	-	-	-	-	-	-
Jet Fuel JP1 ²	Liquid	1	1	-	X	1	X	X	2	X	1	X	-	1	X	-	-	-	-	-	-
Jet Fuel JP10 (Tetrahydrodicyclopentadiene) ²	Liquid	1	-	-	X	X	X	X	X	X	1	X	-	1	X	-	-	-	-	-	-
Jet Fuel JP4 ²	Liquid	1	1	-	X	1	X	X	2	X	1	X	-	1	X	2	1	1	2	1	-
Jet Fuel JP5 ²	Liquid	1	1	-	X	1	X	X	X	X	1	X	-	1	X	2	1	1	2	1	-
Jet Fuel JP8 ²	Liquid	1	1	-	X	1	X	X	X	X	1	X	-	1	X	2	1	1	2	1	-
K																					
Kaolin Clay	White to Yellowish Powder	1	-	1	-	-	-	1	-	-	-	-	-	-	-	-	-	-	-	-	-
Karo Syrup	Yellow Liquid	-	-	-	-	-	-	-	-	-	-	-	1	1	-	1	1	-	-	-	-
Kerosene	Water White Oily Liquid	1	1	-	X	1	X	X	X	X	1	X	1	1	2	1	1	1	1	1	-
Ketchup	Red Liquid	-	-	-	-	1	-	-	1	-	-	-	1	-	-	1	1	-	-	-	-
Ketoglutaric Acid	In Water or Alcohol	1	1	1	2	-	-	-	-	-	-	-	-	-	-	-	-	-	-	-	-
Ketones (ie Acetone, MEK, Cyclohexanone)	Generally Liquids	1	1	1	2	X	X	X	X	2	X	X	-	1	X	1	1	1	1	1	-
Koch Acid	White Solid	-	-	-	-	-	-	1	-	-	-	-	-	-	-	-	-	-	-	-	-
L																					
Lacquer - Alcohol or Acetate as Solvent	Solution	1	1	1	2	-	-	-	-	X	-	-	-	-	X	X	1	1	1	1	-
Lacquer - Toluene or Xylene as Solvent	Solution	1	-	-	-	X	X	X	X	X	1	X	-	1	X	X	X	1	1	1	-
Lactic Acid (90% or less)	Colorless-Yellow Liquid	1	1	1	2	X	2	2	1	-	1	1	-	-	X	X	2	1	X	2	-
Lactic Acid, Food Grade - 50-80%	Colorless to Yellow Liquid	1	1	1	2	-	X	X	-	X	1	1	-	-	-	X	2	1	X	2	-
Lactic Acid, Plastic Grade - 50-80% or less	Colorless to Yellow Liquid	1	1	1	2	1	-	-	1	-	1	1	-	X	1	X	2	1	X	2	-
Lactic Acid, USP 85-90% or less	Colorless to Yellow Syrupy Liquid	-	-	-	-	-	-	-	-	-	-	-	-	-	-	X	2	1	X	2	-
Lactol	-	1	1	-	-	2	-	-	2	-	-	-	-	-	-	1	1	1	1	1	-
Lard (Fat of the Hog)	Liquid above 108°F (42°C)	1	1	1	X	1	X	X	2	X	1	X	1	1	-	1	1	1	1	X	-
Lard Oil	Colorless to Yellow Liquid	1	1	-	-	-	-	-	2	-	X	-	-	-	-	1	1	1	1	X	-
Lasso (Alachlor)	Colorless Crystals	1	1	-	-	-	1	-	-	-	-	-	-	-	-	1	1	-	-	-	-
Latex Paint	Liquid	1	1	1	1	1	2	2	-	2	1	-	-	1	1	1	1	1	1	1	-
Lauryl Peroxide	White Powder	-	-	-	-	-	1	-	-	-	-	-	-	-	-	-	-	-	-	-	-
Lauryl Alcohol	Liquid above 75°F (24°C)	1	-	-	-	-	-	-	-	1	-	-	-	-	-	-	-	-	-	-	-
Lead Acetate	White Crystals	-	-	-	-	-	1	-	-	-	-	-	-	-	2	1	1	-	1	-	-
Lead Acetate Solution	Solution	1	1	1	1	2	2	2	-	2	1	-	1	-	1	2	1	1	-	1	-
Lead Arsenate	White Crystals	1	-	-	-	-	1	-	-	-	-	-	-	-	-	1	1	1	-	-	-
Lead Arsenate Solution (In Nitric Acid)	Solution	1	1	-	-	-	-	-	-	1	2	-	-	-	-	-	-	-	-	-	-
Lead Nitrate Solution (In Water or Alcohol)	Solution	1	1	1	1	1	2	2	2	2	1	-	1	-	1	1	1	1	-	-	-
Lead Silicate (basic)	White Powder	-	-	-	-	-	1	-	-	-	-	-	-	-	-	-	-	-	-	-	-
Lead Sulphate (Basic, Blue Basic, Tribasic)	White to Blue Powder	-	-	-	-	-	1	-	-	-	-	-	-	-	-	1	1	1	-	-	-
Lead, Tetraethyl (Tetraethyl Lead)	Colorless Oily Liquid	1	2	-	X	2	X	X	X	X	1	X	-	2	1	-	-	-	-	-	-
Lead, Tetramethyl (Tetramethyl Lead)	Colorless Liquid	1	-	-	X	2	X	X	X	X	1	X	-	-	-	-	-	-	-	-	-
Lecithin	Light Brown Viscous Liquid-Solid	1	1	-	-	X	-	-	2	-	-	-	-	-	-	-	1	1	-	-	-
Ligroin	Clear Liquid	1	2	-	X	1	X	X	X	X	1	X	-	1	X	2	1	1	-	-	-
Lime (Calcium Oxide)	White to Gray Lumpy Solid	-	-	-	-	-	1	-	-	-	-	-	-	-	-	-	-	2	-	-	-
Lime Sulfur Solution	Solution	1	1	1	2	X	X	X	1	X	1	2	-	-	2	2	1	1	X	X	-
Lime, Chlorinated (Bleaching Solution)	Solution	1	1	1	2	2	2	2	X	2	1	X	-	-	2	X	2	1	-	-	-
Lime, Chlorinated (Normal 35-37% Chlorine)	White Powder	-	-	-	-	-	1	-	-	-	-	-	-	-	-	-	-	2	-	-	-
Lime, Hydraulic (Calcined Limestone)	Powder	-	-	-	-	-	1	-	-	-	-	-	-	-	-	-	-	-	-	-	-

CHEMICAL RESISTANCE TABLE

THE WORLD OF HOSE

Chemical	Form (at room temperature unless otherwise stated)	Gates Hose / Polymers													Couplings / Adapters						
		Teflon®	XLPE	UHMWPE	EPDM	NBR	SBR	NR	CR	Butyl	Fluorocarbon	Hypalon®	CPE	Nylon	PVC	Iron/Carbon Steel	Stainless Steel 304	Stainless Steel 316	Aluminum	Brass	Polypro
Lime, Slaked (Calcium Hydroxide)	White Crystalline Powder	-	-	-	-	-	-	1	-	-	-	-	-	-	-	-	-	-	-	-	-
Limestone	Powder or Lumps	-	-	-	-	-	-	1	-	-	-	-	-	-	-	-	-	-	-	-	-
Limonene	Colorless Liquid	1	2	1	X	X	X	X	-	-	1	-	-	1	-	1	1	1	1	1	-
Lindane (Ag Spray)	-	1	1	-	-	-	-	-	-	-	-	-	1	-	-	1	1	-	-	-	-
Linoleic Acid	Colorless to Straw Colored Liquid	1	1	1	X	2	-	-	X	X	1	-	-	1	-	-	-	-	-	-	-
Linseed Oil	Yellow Amber to Brown Liquid	1	1	X	2	2	X	X	2	-	1	1	1	1	1	2	1	1	1	2	-
Liquid Soap	Liquid	1	1	1	2	-	2	2	-	2	-	-	-	2	1	1	1	1	1	1	-
Lithium Chloride	White Crystals	-	-	X	-	-	-	1	-	-	-	-	-	-	-	-	-	-	-	-	-
Lithium Chloride (35-40% Brine)	Solution	X	1	X	-	-	-	-	-	-	1	-	-	-	-	-	-	-	-	-	-
Lubricating Oil Diester Under 135°F [57°C]	Liquid	1	1	-	X	2	X	X	-	X	1	-	-	X	1	1	1	1	1	1	-
Lubricating Oil [SAE 10, 20, 30, 40, & 50]	Liquid	1	-	-	-	2	-	-	2	-	-	-	1	-	1	1	1	1	1	1	-
Lubricating Oil Under 120°F [49°C]	Liquid	1	1	-	X	1	X	X	2	X	1	2	1	1	2	1	1	1	1	1	-
M																					
Machine Oil Under 135°F [57°C]	Liquid	1	1	-	X	1	X	X	1	X	1	2	-	1	2	1	1	1	1	1	-
Magnesite	White to Brown Crystalline Solid	-	-	-	-	-	-	1	-	-	-	-	-	-	-	-	-	-	-	-	-
Magnesium	Powder	-	-	-	-	-	-	1	-	-	-	-	-	-	-	-	-	-	-	-	-
Magnesium Acetate	Colorless Crystalline Aggregate	-	-	-	-	-	-	1	-	-	-	-	-	-	-	-	-	-	-	-	-
Magnesium Acetate Solution	In Water or Alcohol	1	1	1	1	1	1	1	-	1	1	1	1	1	1	-	-	-	-	-	-
Magnesium Carbonate	White Powder	-	-	-	-	-	-	1	-	-	-	-	-	-	-	1	1	1	-	-	-
Magnesium Carbonate Solution (in Acid)	Liquid Solution	1	1	1	-	-	-	-	-	1	-	-	-	-	-	1	1	1	-	-	-
Magnesium Chloride	Colorless to White Crystals	1	-	1	-	-	-	1	-	-	-	-	-	-	X	2	1	X	2	-	-
Magnesium Chloride Brine	Solution	1	1	1	1	1	-	1	-	-	1	-	-	-	-	-	-	-	-	-	-
Magnesium Chloride, Hydrated (in H2O or Alcohol)	Solution	1	1	1	1	-	-	1	-	-	1	-	-	-	-	-	-	-	-	-	-
Magnesium Hydroxide	White Powder	-	-	-	-	-	-	1	-	-	-	-	-	-	-	1	1	1	X	-	-
Magnesium Hydroxide Solution (in Dilute Acid)	Liquid Solution	1	1	1	-	-	-	-	-	1	-	-	-	-	-	1	1	1	X	-	-
Magnesium Nitrate	White Crystals	-	-	-	-	-	-	1	-	-	-	-	-	-	-	1	1	1	X	1	-
Magnesium Nitrate Solution (in H2O or Alcohol)	Liquid Solution	1	1	1	1	1	-	-	-	-	1	-	-	-	-	1	1	1	X	1	-
Magnesium Oxide, Dry	White Powder	-	-	-	-	-	-	1	-	-	-	-	-	-	-	-	-	-	-	-	-
Magnesium Oxide, Slurry	-	1	1	-	1	2	-	2	1	-	1	-	-	-	-	-	-	-	-	-	-
Magnesium Sulfate Solution	Liquid Solution	1	1	1	1	1	1	1	2	1	1	1	1	-	1	2	1	1	-	1	-
Malathion (Ag Spray Dilute)	Clear to Amber Liquid	1	1	1	2	-	X	X	-	1	1	-	-	1	1	1	1	1	-	1	-
Malathion (Ag Spray)	Clear to Amber Liquid	1	1	-	2	-	-	-	-	1	-	-	-	1	-	1	1	1	-	1	-
Maleic Acid	Liquid	NO HOSE AVAILABLE														2	2	1	-	-	-
Maleic Acid Solution	Solution	1	1	1	1	2	2	2	X	-	7	-	-	-	X	2	2	1	-	-	-
Maleic Anhydride	Colorless Needles	1	-	-	-	-	-	-	-	-	-	-	-	-	-	-	-	-	-	-	-
Maleic Anhydride (Heated Liquid)	Liquid above 124°F [53°C]	1	-	X	-	-	-	-	-	-	-	-	-	-	-	-	-	-	-	-	-
Malic Acid (dl form)	Colorless Crystals	-	-	-	-	-	-	1	-	-	-	-	-	-	-	-	-	-	-	-	-
Malic Acid Solution (in H2O or Alcohol)	Solution	1	1	1	2	-	-	-	-	-	1	-	-	-	-	-	-	-	-	-	-
Malt Extract (Maltine)	Light Brown Viscous Liquid	1	1	1	1	-	-	-	-	-	1	-	-	-	-	-	-	-	-	-	-
Malt, Dry	Yellow to Amber Grain	-	-	-	-	-	-	1	-	-	-	-	-	-	-	-	-	-	-	-	-
Maltine (Malt Extract)	Light Brown Viscous Liquid	1	1	1	1	-	-	-	-	-	1	-	-	-	-	-	-	-	-	-	-
Manganese Salts	-	1	1	-	-	1	X	X	-	-	1	1	-	-	1	-	-	-	-	-	-
Manganese Sulfate (Manganous Sulfate)	Pale Red Solid	-	-	-	-	-	-	1	-	-	-	-	-	-	-	-	-	-	-	-	-
Manganese Sulfate Solution	Solution in Water	1	1	-	-	1	2	2	-	-	1	1	1	-	1	-	-	-	-	-	-
Manganese Sulfide (Manganous Sulfide)	Green Crystals	-	-	-	-	-	-	1	-	-	-	-	-	-	-	-	-	-	-	-	-
Manganese Sulfite (Manganous Sulfite)	Black to Brownish Red Powder	-	-	-	-	-	-	1	-	-	-	-	-	-	-	-	-	-	-	-	-
MAPP Gas (Methylacetylene Propadiene)	Liquid	USE 20B-HB HOSE ONLY														-	-	-	-	-	-
Maxmul (Penzoil Hydraulic Fluid)	Liquid	1	-	-	-	1	-	-	2	-	-	-	-	-	-	1	-	1	-	-	-
Mayonnaise	Semi-Liquid	1	1	-	-	-	-	-	-	-	-	-	-	-	1	-	-	-	-	-	-
MBK (Methyl Butyl Ketone)	Colorless Liquid	1	1	-	2	X	X	X	X	2	X	X	2	-	X	1	1	1	1	1	-
MEA (Ethanolamine)	Colorless Viscous Liquid	1	1	1	2	2	2	2	2	1	X	X	1	-	2	-	-	-	-	-	-
MEK (Ethyl Methyl Ketone)	Colorless Liquid	1	2	1	2	X	X	X	X	2	X	X	2	1	X	1	1	1	1	1	-

Chemical	Form (at room temperature unless otherwise stated)	Gates Hose / Polymers														Couplings / Adapters					
		Teflon®	XLPE	UHMWPE	EPDM	NBR	SBR	NR	CR	Butyl	Fluorocarbon	Hypalon®	CPE	Nylon	PVC	Iron/Carbon Steel	Stainless Steel 304	Stainless Steel 316	Aluminum	Brass	Polypro
		NOTE: Ratings are for the affect on the polymer only!																			
Mercuric Chloride	White Powder	-	-	-	-	-	-	1	-	-	-	-	-	-	-	X	1	1	X	X	-
Mercuric Chloride Solution (in H2O, or Alcohol)	Solution	1	1	-	2	2	2	1	1	2	-	1	1	-	2	X	1	1	X	X	-
Mercuric Cyanide	Colorless Transparent Prisms	-	-	-	-	-	-	1	-	-	-	-	-	-	-	-	-	-	X	-	-
Mercuric Cyanide Solution (in H2O or Alcohol)	Solution	1	1	-	2	2	2	2	1	2	-	1	-	-	-	-	-	-	X	-	-
Mercurous Nitrate Solution	Solution	1	1	1	2	-	-	-	-	1	-	-	-	-	-	1	1	1	X	-	-
Mercury	Silver Liquid	1	1	1	-	2	2	2	1	2	-	1	1	-	1	1	1	1	X	X	-
Mercury Vapor	Gas	NO HOSE AVAILABLE														1	1	1	-	-	-
Mesityl Oxide (Methyl Isobutenyl Ketone)	Colorless Oily Liquid	1	1	1	2	X	X	X	X	2	X	X	2	-	X	1	1	1	1	1	-
Mesitylene (Trimethylbenzene)	Liquid	1	-	-	X	X	X	X	X	X	1	-	-	1	X	-	-	-	-	-	-
Metallic Soaps (Aluminium, Calcium, Zinc)	Solids @ Room Temperature	1	1	1	X	1	X	X	-	X	1	2	1	-	-	1	1	1	1	1	-
Methyl Alcohol (Methylalyl Alcohol)	Colorless Liquid	1	-	-	-	1	-	2	-	2	2	2	-	-	-	-	-	-	-	-	-
Methane	Gas	1	-	-	-	1	-	-	-	-	1	-	-	-	-	-	-	-	-	-	-
Methanol (Methyl Alcohol)	Colorless Liquid	1	1	1	1	1	1	1	1	1	X	1	1	1	2	1	1	1	1	2	-
Methionine	White Crystalline Powder	-	-	-	-	-	-	1	-	-	-	-	-	-	-	-	-	-	-	-	-
Methoxychlor Solution (in Alcohol)	Solution	1	1	-	-	-	-	-	-	-	-	-	-	1	-	1	1	1	-	-	-
Methylamine (Monomethylamine)	Liquid	1	-	-	-	-	-	-	-	-	-	-	-	1	X	1	1	1	-	-	-
Methyl Acetate	Colorless Liquid	1	2	-	2	X	X	X	X	2	X	X	1	1	X	1	1	1	1	1	-
Methyl Acetoacetate	Colorless Liquid	1	-	-	2	X	-	X	X	2	X	X	-	-	-	-	-	-	-	-	-
Methyl Acetone	Water White Liquid	1	-	-	1	X	-	X	-	2	X	X	-	-	1	-	-	-	-	-	-
Methyl Acrylate (Inhibited)	Colorless Liquid	1	2	-	2	X	X	X	X	X	X	X	-	-	-	1	1	1	1	1	-
Methyl Acrylate Acid (Methylacrylic Acid)	White Solid	1	1	1	2	2	X	X	-	1	1	-	1	X	-	-	-	-	-	-	-
Methyl Alcohol (100%) (Methanol)	Colorless Liquid	1	1	1	1	1	1	1	1	1	1	X	1	1	1	2	1	1	1	1	2
Methyl Bromide	Liquid @ 55 PSIG @ 120°F (49°C)	1	1	-	X	X	X	X	X	X	1	X	-	1	X	1	1	1	-	1	-
Methyl Bromoacetate	Colorless to Straw Colored Liquid	1	1	1	-	-	-	-	-	-	-	-	-	-	-	-	-	-	-	-	-
Methyl Butanethiol (Butyl Mercaptan)	Liquid	1	1	-	X	-	X	X	-	X	1	-	-	-	X	-	1	1	-	-	-
Methyl Butanol (2-Methyl-1-Butanol)	Colorless Liquid	1	1	1	1	1	-	-	-	1	1	-	1	1	1	-	-	-	-	-	-
Methyl Butyl Ketone (MBK)	Colorless Liquid	1	1	-	2	X	X	X	X	2	X	X	2	-	X	1	1	1	1	1	-
Methyl Carbitol (Diethylene Glycol Methyl Ether)	Colorless Liquid	1	1	-	1	-	X	X	-	X	1	X	1	-	-	-	-	-	-	-	-
Methyl Cellulosolve (Diethylene Glycol Methyl Ether)	Colorless Liquid	1	1	-	1	-	X	X	-	X	1	X	1	-	-	-	-	-	-	-	-
Methyl Chloride	Liquid @ 160 PSIG @ 120°F (49°C)	1	2	-	X	X	X	X	X	X	1	X	X	-	X	1	1	1	-	1	-
Methyl Chloroform (1,1,1 Trichloroethane)	Colorless Liquid	1	2	-	X	X	X	X	X	X	1	X	X	X	X	-	-	-	-	-	-
Methyl Chloroformate	Colorless Liquid	1	-	-	X	X	X	X	X	X	1	X	-	-	-	-	-	-	-	-	-
Methyl Cyanide (Acetonitrile)	Colorless Liquid	1	1	2	2	X	2	2	X	X	X	X	1	-	1	1	1	1	-	-	-
Methyl Cyclohexane	Colorless Liquid	1	-	-	X	1	X	X	-	X	1	X	2	1	-	-	-	-	-	-	-
Methyl Ethyl Ketone (MEK)	Colorless Liquid	1	2	1	2	X	X	X	X	2	X	X	2	1	X	1	1	1	1	1	-
Methyl Formate	Colorless Liquid	1	1	-	2	X	X	X	2	2	X	X	-	-	-	1	1	1	1	1	-
Methyl Hexanol	-	1	-	-	-	1	-	1	-	1	2	1	-	-	-	-	-	-	-	-	-
Methyl Hexanone (Methyl Isoamyl Ketone)	Colorless Liquid	1	-	-	-	X	-	X	-	2	X	X	-	-	-	-	-	-	-	-	-
Methyl Hexyl Ketone	Colorless Liquid	1	-	-	-	X	-	X	-	2	X	X	-	-	-	-	-	-	-	-	-
Methyl Isoamyl Ketone (Methyl Hexanone)	Colorless Liquid	1	-	-	-	X	-	X	-	2	X	X	-	-	-	-	-	-	-	-	-
Methyl Isobutenyl Ketone (Mesityl Oxide)	Colorless Oily Liquid	1	1	1	2	X	X	X	X	2	X	X	2	-	X	1	1	1	1	1	-
Methyl Isobutyl Ketone (MIBK)	Colorless Liquid	1	2	-	-	X	X	X	X	2	X	X	2	1	X	-	-	-	-	-	-
Methyl Isopropyl Ketone	Colorless Liquid	1	2	-	2	X	X	X	X	2	X	X	2	1	X	1	1	1	1	1	-
Methyl Methacrylate	Colorless Liquid	1	2	-	2	X	X	X	X	X	X	2	2	-	1	1	1	1	-	-	-
Methyl Methacrylate Monomer, Inhibited	Colorless Liquid	1	-	-	X	X	X	X	X	X	X	X	-	X	X	-	-	-	-	-	-
Methyl Phenol (Cresol)	Liquid above 95°F (35°C)	1	2	-	-	X	X	X	X	2	1	X	1	X	-	2	1	1	1	-	2
Methyl Propyl Carbinol (2 Pentanol)	Colorless Liquid	1	1	1	1	-	-	-	-	1	1	-	1	-	-	-	-	-	-	-	-
Methyl Propyl Ether	Colorless Liquid	1	-	-	-	X	-	X	-	X	-	2	-	-	-	-	-	-	-	-	-
Methyl Propyl Ketone (Pentanone)	Water White Liquid	1	-	-	2	X	-	X	X	2	X	X	-	-	X	-	-	-	-	-	-
Methyl Salicylate	Yellow to Red Liquid	1	1	-	2	2	-	-	2	2	-	-	-	-	1	1	1	1	1	1	-
Methyl Stearate	Liquid above 99°F (38°C)	1	1	-	-	-	-	-	-	-	-	-	-	-	-	-	-	-	-	-	-
Methyl Sulfate (Dimethyl Sulfate)	Colorless Liquid	1	1	-	X	X	X	X	X	2	X	X	-	1	1	-	-	-	-	-	-

CHEMICAL RESISTANCE TABLE

THE WORLD OF HOSE

Chemical	Form (at room temperature unless otherwise stated)	Gates Hose / Polymers													Couplings / Adapters						
		Teflon®	XLPE	UHMWPE	EPDM	NBR	SBR	NR	CR	Butyl	Fluorocarbon	Hypalon®	CPE	Nylon	PVC	Iron/Carbon Steel	Stainless Steel 304	Stainless Steel 316	Aluminum	Brass	Polypro
Methyl-2-Pyrrolidone	Colorless Liquid	-	2	-	-	-	-	-	-	-	-	-	-	-	-	-	-	-	-	-	-
Methyl-n-Amyl Carbinol	Colorless Liquid	1	1	-	-	-	-	-	-	-	-	-	-	1	-	-	-	-	-	-	-
Methyl-n-Amylketone	Water White Liquid	1	1	-	-	-	-	-	-	-	-	-	-	-	-	-	-	-	-	-	-
Methylacetylene Propadiene [MAPP Gas]	Liquid @ 107 PSIG @ 20°C	1	-	-	-	-	-	-	-	-	-	1	-	-	-	-	-	-	-	-	-
Methylacrylic Acid [Crotonic Acid]	White Crystalline Solid	1	1	1	2	2	X	X	-	1	1	-	1	X	-	-	-	-	-	-	-
Methylal	Colorless Liquid	1	-	-	-	-	-	-	-	-	-	-	1	-	-	-	-	-	-	-	-
Methylalyl Alcohol [Methylal Alcohol]	Colorless Liquid	1	-	-	-	1	-	2	-	2	2	2	-	-	-	-	-	-	-	-	-
Methylalyl Chloride	Colorless to Straw Colored Liquid	1	-	-	-	-	-	-	-	-	1	-	-	-	-	-	-	-	-	-	-
Methylamine [30-40% in H2O]	Colorless Liquid	1	1	-	2	X	-	-	-	-	-	-	-	-	X	-	-	-	-	-	-
Methylamine [Anhydrous]	Liquid @ 120 PSIG @ 49°C	1	-	-	-	-	-	-	-	-	-	-	-	-	X	-	-	-	-	-	-
Methylamyl Acetate	Colorless Liquid	1	-	-	-	-	-	-	-	-	-	-	-	-	-	-	-	-	-	-	-
Methylamyl Alcohol	Colorless Liquid	1	1	-	-	-	-	-	-	-	1	-	-	-	-	-	-	-	-	-	-
Methylaniline	Colorless to Brown Liquid	1	1	1	2	X	-	-	X	-	1	2	-	X	X	-	-	-	-	-	-
Methyldiethanolamine	Colorless Liquid	1	1	-	-	-	-	-	-	-	-	-	-	-	-	-	-	-	-	-	-
Methylene Bromide	Clear Liquid	1	-	-	-	2	-	-	-	-	1	-	-	-	X	-	-	-	-	-	-
Methylene Chloride [Dichloromethane]	Colorless Liquid	1	1	2	X	X	X	X	X	X	2	X	X	X	X	1	1	1	1	1	1
Methylene Dichloride	Colorless Liquid	1	1	-	X	X	X	X	X	X	1	X	X	X	X	1	1	1	X	1	-
Methylene Dichloride [Methylene Chloride]	Colorless Liquid	1	1	2	X	X	X	X	X	X	1	X	X	X	X	1	1	1	X	1	-
Methylene Diphenyl Diisocyanate, MDI	Liquid above 37°C	-	1	-	-	-	-	-	-	-	-	-	-	-	-	-	-	-	-	-	-
Methylstyrene	Colorless Liquid	1	-	-	-	-	-	-	-	-	1	-	-	-	-	-	-	-	-	-	-
MIBK [Methyl Isobutyl Ketone]	Colorless Liquid	1	2	-	-	X	X	X	X	2	X	X	2	1	X	-	-	-	-	-	-
Milk	White Liquid	USE FDA HOSE ONLY																			
Mineral Oil	Colorless Liquid	1	1	1	X	1	X	X	1	X	1	1	1	1	1	1	1	1	2	1	-
Mineral Spirits [VM&P Naphtha]	Colorless Liquid	1	1	-	X	1	X	X	-	X	1	X	-	1	-	1	1	1	2	1	-
MIPA [Isopropanolamine]	Liquid	1	-	-	-	2	-	2	-	1	X	X	-	-	-	-	-	-	-	-	-
Mobile Therm 603	Liquid	1	1	-	-	1	-	-	-	-	1	-	-	-	-	1	1	1	1	1	-
Molasses	Brown Liquid	1	1	-	1	2	2	2	2	1	1	1	-	-	2	2	1	1	2	X	-
Monochloroacetic Acid	Colorless to Light Brown Crystals	1	1	X	-	-	X	-	-	-	-	-	-	-	-	-	-	-	-	-	-
Monochloroacetic Acid Solution [in H2O or Alcohol]	Liquid Solution	1	1	X	2	-	-	-	-	-	-	-	-	X	-	X	X	X	-	2	1
Monochlorobenzene	Clear Liquid	1	2	-	X	X	X	X	X	X	1	X	X	X	X	1	1	1	-	1	-
Monoethanolamine	Colorless Liquid	1	2	1	2	2	2	2	2	2	X	X	1	1	2	1	1	1	-	1	-
Monoethylamine	Liquid @ 15 PSIG @ 120°F (49°C)	1	2	-	1	X	X	X	X	2	X	X	1	-	-	-	1	1	-	1	-
Monoethylamine Solution [70% or less]	Liquid Solution	1	1	-	-	-	-	-	-	-	-	-	-	-	-	-	-	-	-	-	-
Monoglycerides	Liquid to Solid	1	1	-	-	-	-	-	-	-	-	-	-	-	-	-	-	-	-	-	-
Monomethylamine [Methylamine]	Liquid @ 120 PSIG @ 120°F (49°C)	1	-	-	-	-	-	-	-	-	-	-	-	-	X	1	1	1	-	-	-
Monopentaerythritol [Pentaerythritol]	White Powder	-	-	-	-	-	-	1	-	-	-	-	-	-	-	-	-	-	-	-	-
Monopentaerythritol Solution	Liquid Solution	1	1	1	1	-	-	-	-	-	1	-	-	-	-	-	-	-	-	-	-
Monosodium Phosphate [Monobasic]	White Powder	1	1	-	2	-	2	2	X	2	-	-	1	1	1	-	1	1	X	X	-
Morpholine	Colorless Liquid	1	-	-	-	-	-	-	-	-	-	-	-	-	-	-	-	-	-	-	-
Mortar, Inorganic	Powder	-	-	-	-	-	-	1	-	-	-	-	-	-	-	-	-	-	-	-	-
Motor Oil	Liquid	1	1	-	X	1	X	X	2	X	1	2	1	1	2	1	1	1	1	1	-
Mould Oil	Liquid	1	1	-	-	-	-	-	-	-	-	-	-	-	-	1	1	1	-	-	-
Mouth Wash	Liquid	1	-	1	-	-	-	-	-	-	-	-	-	-	-	1	1	1	1	1	-
MTBE [Methyl Tertiary Butyl Ether]	Colorless Liquid	-	2	-	-	-	-	-	-	-	X	-	-	-	-	-	-	-	-	-	-
Muriatic Acid [Hydrochloric]	Colorless to Yellow Liquid	1	1	1	X	X	2	2	X	2	1	2	1	X	X	X	X	X	X	X	-
Mustard	Liquid	1	-	-	-	-	1	1	1	1	-	1	-	-	-	X	1	1	-	-	-
N																					
n-Hexaldehyde	Colorless Liquid	1	1	-	2	X	X	X	2	1	-	-	-	-	-	-	-	-	-	-	-
N-Methyl-2-Pyrrolidone	Colorless Liquid	-	2	-	-	-	-	-	-	-	-	-	-	-	-	-	-	-	-	-	-
n-Octane	Colorless Liquid	1	2	1	X	1	X	X	-	X	1	X	1	1	X	-	-	-	-	-	-
Naphtha [Low Aromatic Content]	Liquid	1	1	-	X	2	X	X	X	X	1	X	1	-	X	2	1	1	-	1	-
Naphthalene	White Crystalline Flakes	-	-	-	-	-	-	1	-	-	-	-	-	-	-	1	1	1	1	1	-

Chemical	Form (at room temperature unless otherwise stated)	Gates Hose / Polymers													Couplings / Adapters						
		Teflon®	XLPE	UHMWPE	EPDM	NBR	SBR	NR	CR	Butyl	Fluorocarbon	Hypalon®	CPE	Nylon	PVC	Iron/Carbon Steel	Stainless Steel 304	Stainless Steel 316	Aluminum	Brass	Polypro
		1	1	1	1	1	1	1	1	1	1	1	1	1	1	1	1	1	1	1	1
Naphthenic Acid	Commercial Grade is Dark Fluid	1	1	-	-	2	-	-	-	-	1	-	-	1	-	-	-	-	-	-	-
Neohexane	Colorless Liquid	1	-	-	X	1	-	-	2	-	1	-	-	1	-	-	-	-	-	-	-
Neutral Oil	Liquid	1	1	1	X	2	X	X	2	X	1	-	-	1	-	1	1	1	-	1	-
Nickel Acetate	Green Crystals	-	-	-	-	-	-	1	-	-	-	-	-	-	-	1	1	1	1	1	-
Nickel Acetate Solution (In Water or Alcohol)	Solution	1	1	1	2	-	2	2	-	1	-	-	-	-	-	1	1	1	1	1	-
Nickel Carbonate	Green to Brown Crystals/Powder	-	-	-	-	-	-	1	-	-	-	-	-	-	-	-	-	-	-	-	-
Nickel Chloride	Brown Deliquescent Scales	-	-	-	-	-	-	1	-	-	-	-	-	-	X	2	2	X	X	-	-
Nickel Chloride Solution (In Water or Alcohol)	Solution	1	1	-	2	2	2	2	2	2	1	2	1	-	1	X	2	2	X	X	-
Nickel Nitrate	Green Deliquescent Crystals	-	-	-	-	-	-	1	-	-	-	-	-	-	-	-	-	2	X	-	-
Nickel Nitrate Solution (In Water or Alcohol)	Solution	1	1	-	2	2	2	2	2	2	1	2	1	-	2	-	-	2	X	-	-
Nickel Plating Solution	Liquid	1	1	-	-	2	2	2	-	-	-	2	-	-	X	-	1	1	-	-	-
Nickel Salts	-	1	1	-	1	1	1	1	1	1	1	1	-	1	2	-	-	-	-	-	-
Nickel Sulfate	Yellow Green to Blue Crystals	-	-	-	-	-	-	1	-	-	-	-	-	-	-	2	1	X	X	-	-
Nickel Sulfate Solution	Solution	1	1	-	2	2	2	2	2	2	1	2	1	-	1	-	2	1	X	X	-
Nicotine Salts (ie Nicotine Hydrochloride)	Colorless Oil	1	1	-	-	-	-	-	-	-	-	-	-	-	1	1	X	2	-	-	-
Niter Cake [Sodium Bisulfate]	Colorless Crystals to White Lumps	1	1	-	1	1	1	1	1	1	1	1	1	1	1	X	1	1	X	X	-
Niter Cake Solution	Solution	1	1	1	2	-	X	X	-	2	1	1	1	-	-	-	-	-	-	-	-
Nitric Acid (25% or less)	Colorless Liquid	1	1	1	2	X	X	X	X	2	1	2	1	X	X	X	2	2	-	X	-
Nitric Acid (10%)	Transparent or Yellowish Liquid	1	1	1	1	X	X	X	X	2	1	2	1	X	X	X	2	2	-	X	-
Nitric Acid (25%)	Transparent or Yellowish Liquid	1	1	1	2	X	X	X	X	2	1	2	1	X	X	X	2	2	-	X	-
Nitric Acid (35% or less, 26 Degrees Baume)	Colorless Liquid	1	1	1	2	X	X	X	X	2	1	1	X	X	X	X	2	2	-	X	-
Nitric Acid (52% or less, 36 Degrees Baume)	Colorless to Yellow Liquid	1	2	X	X	X	X	X	X	X	1	2	X	X	X	X	2	2	-	X	-
Nitric Acid (61% or less, 40 Degrees Baume)	Colorless to Yellow Liquid	1	2	X	X	X	X	X	X	X	1	2	X	X	X	X	2	2	-	X	-
Nitric Acid (63.5% or less)	Transparent or Yellowish Liquid	1	X	X	X	X	X	X	X	X	1	X	X	X	X	X	2	2	-	X	-
Nitric Acid (67% or less, 42 Degrees Baume)	Colorless to Yellow Liquid	1	X	X	X	X	X	X	X	X	1	X	X	X	X	X	2	2	-	X	-
Nitric Acid (95% or less, 48.5 Degrees Baume)	Yellow Liquid	1	X	X	X	X	X	X	X	X	1	X	X	X	X	X	2	2	-	X	-
Nitric Acid (Red Fuming)	Red Liquid	1	X	X	X	X	X	X	X	X	1	X	X	X	X	-	-	-	-	-	-
Nitrobenzene	Yellow Liquid @ 43°F [6°C]	1	2	-	2	X	X	X	X	2	X	X	2	X	1	1	1	1	1	1	-
Nitroethane	Colorless Liquid	1	1	-	2	X	2	2	X	2	-	2	1	-	-	-	-	1	1	1	-
Nitrogen [Cryogenic Liquid]	Liquid	NO HOSE AVAILABLE													1	1	1	1	1	-	
Nitrogen [Gas]	Colorless Gas	1	1	1	1	1	1	1	1	1	1	1	1	1	1	1	1	1	1	1	-
Nitrogen Dioxide [Nitrogen Tetroxide]	Liquid @ 50 PSIG @ 120°F (49°C)	1	-	-	-	-	-	-	-	-	1	-	-	-	-	-	-	-	-	-	-
Nitrogen Fertilizer [Ammonia, Urea]	Solutions in Water	1	1	-	-	-	-	-	-	-	-	-	-	-	-	-	-	-	-	-	-
Nitrogen Oxide [Nitrous Oxide]	Gas	1	1	-	2	X	X	X	X	1	1	1	1	X	X	1	1	1	X	-	-
Nitrogen Tetroxide [Nitrogen Dioxide]	Liquid @ 50 PSIG @ 120°F (49°C)	1	-	-	-	-	-	-	-	-	1	-	-	-	-	-	-	-	-	-	-
Nitromethane	Colorless Liquid	1	-	-	2	X	-	2	X	2	X	X	-	1	X	-	1	1	-	1	-
Nitropropane	Colorless Liquid	1	1	-	2	X	X	X	X	2	X	-	-	1	-	-	1	1	-	1	-
Nitrosyl Chloride	Yellow-Red Liquid or Gas	1	1	-	-	-	-	-	-	-	-	-	-	-	-	-	1	1	-	-	-
Nitrous Acid (Up to 10%)	Light Blue Liquid	1	1	1	-	-	-	1	-	-	1	-	1	1	X	1	1	X	X	-	-
Nitrous Oxide [Nitrogen Oxide]	Gas	1	1	-	2	X	X	X	X	1	1	1	1	X	X	1	1	1	X	-	-
Nitrous Oxide, Compressed Liquid	Liquid @ 800 PSIG @ 68°F [20°C]	1	-	-	-	-	-	-	-	-	-	-	-	-	-	-	-	-	-	-	-
Nonene [1-nonylene]	Colorless Liquid	1	-	-	-	-	-	-	-	-	1	-	-	-	-	-	-	-	-	-	-
Nonyl Alcohol [Octyl Carbinol]	Colorless Liquid	1	1	1	-	1	-	-	-	-	1	-	-	-	-	-	-	-	-	-	-
Nonylene [Nonene]	Colorless Liquid	1	-	-	-	-	-	-	-	-	1	-	-	-	-	-	-	-	-	-	-
0																					
Octadecanoic Acid [Stearic Acid]	Colorless Waxy Solid	1	1	1	2	2	2	2	2	2	2	1	2	1	1	1	X	2	1	X	X
Octanoic Acid [Caprylic Acid]	Colorless Oily Liquid	1	-	-	-	-	-	-	-	-	-	-	-	1	-	-	-	-	-	-	-
Octanol [Octyl Alcohol]	Colorless Liquid	1	1	-	-	2	2	2	2	-	1	-	1	1	2	1	1	1	1	2	-
Octene	Colorless Liquid	1	-	-	-	-	-	-	-	-	1	-	-	-	-	-	-	-	-	-	-
Octyl Acetate	Colorless Liquid	1	-	-	-	X	-	X	-	X	X	1	-	-	-	-	-	-	-	-	-
Octyl Alcohol [Octanol]	Colorless Liquid	1	1	-	-	2	2	2	2	-	1	-	1	1	2	1	1	1	1	2	-
Octyl Aldehyde	Colorless Liquid	1	-	-	-	X	-	X	-	X	X	X	-	-	-	-	-	-	-	-	-

CHEMICAL RESISTANCE TABLE

THE WORLD OF HOSE

Chemical	Form (at room temperature unless otherwise stated)	Gates Hose / Polymers														Couplings / Adapters					
		Teflon®	XLPE	UHMWPE	EPDM	NBR	SBR	NR	CR	Butyl	Fluorocarbon	Hypalon®	CPE	Nylon	PVC	Iron/Carbon Steel	Stainless Steel 304	Stainless Steel 316	Aluminum	Brass	Polypro
Octyl Carbinol (Nonyl Alcohol)	Colorless Liquid	1	1	1	-	1	-	-	-	-	1	-	-	-	-	-	-	-	-	-	-
Octyl Phenol [Diisobutyl Phenol]	White Flakes	1	-	-	-	-	-	1	-	-	-	-	-	-	-	-	-	-	-	-	-
Octylamine	Water White Liquid	1	-	-	-	X	-	X	-	2	X	X	-	-	-	-	-	-	-	-	-
Oil (SAE Motor Oils)	Liquid	1	1	-	X	1	X	X	2	X	1	2	1	1	2	-	-	-	-	-	-
Oil of Turpentine	Liquid	1	2	2	X	1	X	X	2	X	1	X	-	1	1	-	-	-	-	-	-
Oils, Animal (High Fatty Acid Content)	Solid to Liquids	1	2	-	X	1	X	X	2	2	1	X	1	-	2	1	1	1	1	1	-
Oils, Mineral (Aliphatic or Aromatic)	Liquids	1	2	-	X	2	X	X	X	X	1	2	2	1	X	-	-	-	-	-	2
Oils, Vegetable (Soybean, Coconut, Corn)	Liquids	1	1	-	X	1	X	X	-	X	1	X	-	1	-	-	-	-	-	-	1
Oleic Acid (fatty acid)	Yellow to Red Oily Liquid	1	2	2	2	X	X	X	2	2	2	X	2	-	2	2	2	1	1	2	1
Oleum (Fuming Sulfuric, 30% SO3 or less)	Clear to Off White Fuming Liquid	1	X	X	X	X	X	X	X	X	1	X	X	X	X	-	-	1	-	-	X
Olive Oil	Yellow to Green Liquid	1	1	1	2	2	X	X	X	2	1	X	2	1	2	2	1	1	1	2	1
Ortho-Dichlorobenzene (also meta and para)	Colorless Liquid	1	2	-	X	X	X	X	X	X	1	X	X	1	X	-	1	1	-	1	-
Ortho-xylene (1,2 Dimethylbenzene)	Clear Colorless Liquid	1	X	X	X	X	X	X	X	X	1	X	X	X	X	-	-	-	-	-	-
OS 45 Hydraulic Fluid (Silicate Ester Base)	Liquid	1	-	-	X	2	X	X	1	X	1	2	-	-	-	-	-	-	-	-	-
Oxalic Acid	Transparent Crystals	1	-	2	-	-	-	1	-	-	-	-	-	-	X	2	1	2	X	1	-
Oxalic Acid (50%)	Crystals in H2O	1	2	1	2	X	X	X	X	2	1	2	1	X	X	-	-	-	-	-	-
Oxygen	Colorless Gas	1	1	-	1	2	2	2	-	1	1	1	1	-	-	-	-	-	-	-	-
Oxygen, Refrigerated Liquid	Liquid @ 200 PSIG @ -146°C	NO HOSE AVAILABLE																			
Ozone	Gas	1	2	2	1	X	X	X	2	2	2	2	2	1	2	1	1	1	1	1	1
P																					
Paint (Emulsion or Latex)	Liquid	1	1	1	2	2	-	-	-	-	1	-	-	1	1	-	-	-	-	-	-
Paint (Inorganic)	Liquid	1	-	1	-	-	-	-	-	-	-	-	-	-	-	-	1	1	1	1	-
Paint (Oil or Solvent Based)	Liquid or Paste	1	1	-	X	2	X	X	-	X	1	X	-	1	-	-	-	-	-	-	-
Paint Remover	Liquid or Paste	1	2	-	X	X	X	X	X	X	1	X	-	X	-	-	-	-	-	-	-
Paint Resin	-	1	-	-	-	-	-	-	-	-	-	-	-	-	-	-	-	-	-	-	-
Palm Oil	Yellow to Brown Solid	1	1	-	-	1	X	X	2	2	-	2	-	-	-	1	1	1	1	1	-
Palmitic Acid (Hexadecanoic Acid)	Crystals in Hot Alcohols	1	1	1	2	2	X	X	2	2	1	X	1	-	-	1	2	1	1	X	1
Papermakers Alum (Aluminum Ammonium Sulfate)	In Water	1	1	-	-	-	-	-	-	-	-	-	-	-	-	-	-	-	-	-	-
Paraffin (Aliphatic Hydrocarbon)	Varies from Gas to Waxy Solid	1	1	1	X	1	X	X	2	X	1	X	1	-	-	2	1	1	-	1	-
Paraformaldehyde	White Solid - Flakes or Powder	1	-	-	-	2	-	1	2	-	-	-	-	-	1	-	1	1	1	-	-
Paraldehyde	Colorless Liquid	1	-	-	-	-	-	-	-	-	-	-	-	-	-	-	-	-	-	-	-
Paranox (Detergent, Disperser; Exxon)	-	1	-	1	-	-	-	-	-	-	-	-	-	-	-	-	-	-	-	-	-
Parapol (Liquid Polyisobutylene; Exxon)	Liquid	1	-	-	-	-	-	-	-	-	1	-	-	-	-	-	-	-	-	-	-
Peanut Oil	Yellow to Green Liquid	1	1	-	-	1	-	-	2	X	-	-	-	-	2	1	1	1	1	1	1
Petargonic Acid	Colorless to Yellow Oil	1	-	-	-	-	-	-	-	-	-	-	-	-	-	-	-	-	-	-	-
Pentachloroethane	Colorless Liquid	1	-	-	-	-	-	-	-	-	1	-	-	-	-	-	-	-	-	-	-
Pentachlorophenol In Oil	In Oil (Wood Preservative)	1	1	1	X	X	X	X	X	1	1	-	-	-	X	-	-	-	-	-	-
Pentaerythritol (Monopentaerythritol)	White Powder	-	-	-	-	-	-	1	-	-	-	-	-	-	-	-	-	-	-	-	-
Pentane	Colorless Liquid	1	X	X	X	-	-	-	-	-	1	-	1	-	-	-	-	-	-	-	-
Pentanol (Methyl Propyl Carbinol)	Colorless Liquid	1	1	1	1	-	-	-	-	1	1	-	1	-	-	-	-	-	-	-	-
Pentanone (Methyl Propyl Ketone)	Water White Liquid	1	-	-	2	X	-	X	X	2	X	X	-	X	-	-	-	-	-	-	-
Pentasol (Amyl alcohols, primary and secondary)	Liquid	1	2	2	2	2	2	2	2	2	1	2	1	1	2	1	1	1	1	1	-
Perchloric Acid (70%)	70% or Less with H2O	1	2	1	-	-	2	2	2	2	1	2	-	X	X	-	2	1	-	-	1
Perchloroethylene	Colorless Liquid	1	2	-	X	X	X	X	X	X	1	X	2	2	X	1	1	1	-	X	-
Petroleum Coke	Solid Pellets	-	-	-	-	-	-	1	-	-	-	-	-	-	-	-	-	-	-	-	-
Petroleum Distillate	Liquid	1	-	-	-	-	-	-	-	-	1	-	-	-	-	-	-	-	-	-	-
Petroleum Ether (Naptha)	Liquid	1	1	-	X	2	X	X	X	X	1	X	1	-	X	2	1	1	-	1	-
Petroleum Naptha (Toluene/cyclohexane/Xylene)	Liquid	1	X	X	X	X	X	X	X	X	1	X	X	X	X	-	-	-	-	-	-
Petroleum Naptha Flash Point Over 200 Degrees	Liquid	1	-	-	-	-	-	-	-	-	-	1	-	-	-	-	-	-	-	-	-
Petroleum Oils (Refined)	Liquid	1	1	1	X	1	X	X	2	X	1	2	-	1	1	-	-	-	-	-	-
Petroleum Oils (Sour)	Liquid	1	1	1	X	1	X	X	2	X	1	X	-	-	2	-	-	-	-	-	-
Petroleum Paraffin Wax	Solid with low Melt Points	1	2	2	X	-	-	-	-	-	1	-	-	-	-	-	-	-	-	-	-

Chemical	Form (at room temperature unless otherwise stated)	Gates Hose / Polymers														Couplings / Adapters					
		Teflon®	XLPE	UHMWPE	EPDM	NBR	SBR	NR	CR	Butyl	Fluorocarbon	Hypalon®	CPE	Nylon	PVC	Iron/Carbon Steel	Stainless Steel 304	Stainless Steel 316	Aluminum	Brass	Polypro
Phenol (Carbolic Acid)	White or Pink Crystals	1	2	-	2	X	X	X	X	2	1	X	1	X	X	X	1	1	2	X	-
Phenol Acid	95% or less with H2O	1	2	2	2	X	X	X	X	2	1	X	1	X	X	X	1	1	-	X	-
Phenolates	-	1	-	-	-	X	-	-	X	-	2	X	-	2	-	-	-	-	-	-	-
Phenolsulfonic Acid	Yellow to Brown Liquid	1	-	-	-	-	-	-	-	-	1	-	-	-	-	-	-	-	-	-	-
Phenothiazine	Greenish Powder or Flakes	-	-	-	-	-	-	1	-	-	-	-	-	-	-	-	-	-	-	-	-
Phenyl Acetate	Water White Liquid	1	-	-	-	-	-	-	-	-	-	-	-	-	-	-	-	-	-	-	-
Phenyl Chloride (Chlorobenzene)	Clear Volatile Liquid	1	2	-	X	X	X	X	X	X	1	X	X	X	X	1	1	1	1	1	X
Phenylenediamine (ortho)	Colorless to Red Solid Needles	-	-	-	-	-	-	1	-	-	-	-	-	-	-	-	-	-	-	-	-
Phorone (Diisopropylidene Acetone)	Yellow Liquid	1	1	-	2	X	X	X	X	2	X	X	-	-	-	1	1	1	-	1	-
Phosgene (Carbonyl Chloride)	Gas, Liquid 60 PSI @ 120°F (49°C)	1	X	X	X	X	X	X	X	2	1	X	-	2	-	-	-	-	-	-	-
Phosphate Ester Hydraulic Fluid	Liquid	1	1	1	1	X	X	X	X	-	-	X	-	2	-	-	-	-	-	-	-
Phosphate Rock	Solid	-	-	-	-	-	-	1	-	-	-	-	-	-	-	-	-	-	-	-	-
Phosphate, Trisodium	In Water	1	1	1	-	-	-	-	-	1	-	-	-	-	-	-	-	-	-	-	-
Phosphoric Acid (100%)	Crystals	1	2	X	2	-	-	-	-	1	-	-	-	-	-	-	-	-	-	-	-
Phosphoric Acid (35% or less)	Colorless Liquid	1	1	1	1	2	2	2	2	2	1	1	1	-	-	X	1	1	X	2	1
Phosphoric Acid (50%)	Colorless Liquid	1	1	1	1	2	2	2	2	2	1	1	1	X	X	X	1	1	X	2	1
Phosphoric Acid (75%)	Colorless Liquid	1	2	1	2	-	-	-	-	-	1	1	1	X	X	X	2	2	X	X	1
Phosphoric Acid (85%)	Syrupy Liquid	1	2	1	2	X	X	X	X	X	1	1	1	X	X	X	2	2	X	X	1
Phosphoric Acid (90%)	Syrupy Liquid	1	2	1	2	-	-	-	-	-	1	-	-	-	-	-	-	-	-	-	-
Phosphoric Acid, Spent	Liquid	1	1	-	1	-	-	-	-	-	1	-	-	-	-	-	-	-	-	-	-
Photographic, Developers	-	1	-	-	-	-	-	-	-	-	-	-	-	-	-	-	-	-	-	-	-
Photographic, Emulsions	Liquid	1	-	-	-	-	-	-	-	-	-	-	-	-	-	-	-	-	-	-	-
Photographic, Fixing Solutions	Liquid	1	-	-	-	-	-	-	-	-	-	-	-	-	1	-	-	-	-	-	-
Phthalic Acid	Colorless Crystals	-	-	-	-	-	-	1	-	-	-	-	-	-	-	-	-	-	-	-	-
Phthalic Acid (50%)	Colorless Liquid	1	-	1	-	-	-	-	-	-	-	-	-	-	-	-	-	-	-	-	-
Phthalic Anhydride, Molten	White Crystalline Solid	-	-	X	-	-	-	-	-	-	-	-	-	-	-	-	-	-	-	-	-
Picric Acid (Solution)	In Water	1	2	2	2	-	-	-	-	-	1	-	-	-	-	X	1	1	X	X	1
Picric Acid (Trinitrophenol)	Yellow Crystals	1	2	2	2	2	2	2	2	2	1	2	-	X	1	X	1	1	X	X	1
Pine Oil	Colorless to Amber Liquid	1	1	-	X	2	X	X	-	X	2	X	2	-	-	-	-	-	-	-	-
Pine Tar	Viscous Brown to Black Liquid	1	2	-	-	-	-	-	-	-	1	-	-	-	-	-	-	-	-	-	-
Pinene	Colorless Transparent Liquid	1	1	-	X	2	X	X	X	X	1	-	2	1	X	1	1	1	-	-	-
Piperazine Hydrochloride Solution (34%)	In Water	1	1	-	-	2	-	-	-	-	-	-	-	-	-	-	-	-	-	-	-
Pitch	In Aromatic Hydrocarbons	1	2	X	X	2	X	X	X	X	1	X	-	1	X	-	-	-	-	-	-
Plating Solution Chrome Under 120°F (49°C)	Liquid	1	1	-	2	-	-	-	-	2	2	-	-	X	X	-	X	X	-	-	1
Pluronic (Block Polymer with Hydroxyl by BASF)	Liquid	1	1	1	1	-	-	-	-	-	1	-	-	-	-	-	-	-	-	-	-
Polyester Plastic	-	1	1	-	-	-	-	-	-	-	2	-	-	2	-	-	-	-	-	-	-
Polyethylene Glycol	Colorless Liquid to glassy Solid	1	-	-	1	2	-	1	1	1	1	1	-	2	2	-	-	-	-	-	-
Polyethylene Plastic	Solid Beads	-	-	-	-	-	-	1	-	-	-	-	-	-	-	-	-	-	-	-	-
Polypropylene Glycol	Liquid	1	1	-	1	1	-	1	1	1	1	1	-	-	-	-	-	-	-	-	-
Polypropylene Plastic	Solid Beads	-	-	-	-	-	-	1	-	-	-	-	-	-	-	-	-	-	-	-	-
Polystyrene Plastic	Solid Beads	-	-	-	-	-	-	1	-	-	-	-	-	-	-	-	-	-	-	-	-
Polyurethane Foam Under 125°F (52°C)	-	1	1	-	2	-	-	-	-	-	2	2	-	-	-	-	-	-	-	-	-
Polyvinyl Acetate - Emulsions	Emulsion	1	-	-	1	1	-	1	2	1	-	1	-	-	-	-	-	-	-	-	-
Potash (Potassium Carbonate) Aqueous Solution	Liquid	1	1	-	1	-	1	1	1	1	1	1	-	1	1	2	1	1	-	X	1
Potassium Acetate	White Powder	1	1	-	2	2	2	2	2	2	X	2	1	-	1	-	1	1	-	-	1
Potassium Bicarbonate	Colorless crystal or white Powder	1	1	-	1	1	1	1	1	1	1	1	-	1	1	-	-	-	-	-	-
Potassium Bisulfate	Colorless crystal	1	1	-	1	1	1	1	1	1	1	1	-	1	1	-	-	-	-	-	-
Potassium Bromate	White Crystal or Powder	1	-	-	-	-	-	-	-	-	-	-	-	-	-	-	-	-	-	-	1
Potassium Bromide	White Crystals or Powder	1	1	-	1	1	1	1	1	1	1	1	-	1	1	-	-	-	-	-	-
Potassium Carbonate	White granular Powder	1	1	-	1	1	1	1	1	1	1	1	1	1	1	2	1	1	-	X	1
Potassium Carbonate, Liquid	Colorless to Cloudy Liquid	1	1	-	1	1	1	1	1	1	1	1	-	1	1	2	1	1	-	X	1
Potassium Chlorate	Colorless to white Powder	1	-	-	-	-	-	-	-	-	-	-	-	2	1	-	-	-	-	-	-

CHEMICAL RESISTANCE TABLE

THE WORLD OF HOSE

Chemical	Form (at room temperature unless otherwise stated)	Gates Hose / Polymers													Couplings / Adapters						
		Teflon®	XLPE	UHMWPE	EPDM	NBR	SBR	NR	CR	Butyl	Fluorocarbon	Hypalon®	CPE	Nylon	PVC	Iron/Carbon Steel	Stainless Steel 304	Stainless Steel 316	Aluminum	Brass	Polypro
Potassium Chloride	Colorless to white Solid	1	-	-	-	-	-	-	-	-	-	1	1	1	-	-	-	-	-	-	-
Potassium Chloride, Dry	White Solid	1	1	-	1	1	1	1	1	1	1	1	1	1	-	1	1	-	-	-	-
Potassium Chromate	Yellow Crystal	1	2	-	2	X	X	X	2	2	1	2	1	2	1	-	-	-	-	-	1
Potassium Cuprocyanide	White Crystalline Solid	1	-	-	1	1	1	1	1	1	1	1	-	2	1	-	-	-	-	-	1
Potassium Cyanide	White Crystal	1	-	-	-	-	-	-	-	-	-	1	-	-	-	-	-	-	-	-	-
Potassium Dichromate	White Crystalline Powder	1	-	-	-	-	-	-	-	-	-	1	2	1	-	-	-	-	-	-	-
Potassium Ferrocyanide	Yellow Crystal or Powder	1	-	-	-	-	-	-	-	-	-	-	-	1	-	-	-	-	-	-	1
Potassium Fluoride	White Crystalline Powder	1	-	-	-	-	-	-	-	-	-	-	-	-	-	-	-	-	-	-	1
Potassium Hydrate	White Solid	1	-	-	2	2	2	2	2	1	X	1	-	2	2	-	-	-	-	-	-
Potassium Hydroxide (45% Caustic Potash)	Colorless to Cloudy Liquid	1	1	1	2	2	2	2	-	1	2	-	1	1	1	-	-	-	-	-	-
Potassium Hydroxide, Liquid	Colorless to Cloudy Liquid	1	1	-	1	2	2	2	2	1	X	2	-	X	X	-	-	-	-	-	-
Potassium Iodide	White Solid	1	-	-	1	1	-	-	1	-	1	1	-	-	1	-	-	-	-	-	2
Potassium Nitrate	Colorless to white Solid	1	-	-	-	-	-	-	-	-	-	1	1	1	-	-	-	-	-	-	-
Potassium Permanganate	Dark purple Crystal	1	1	-	-	-	-	-	-	-	-	-	X	X	-	-	-	-	-	-	-
Potassium Persulfate	White Crystal	1	-	-	-	-	-	-	-	-	-	-	-	-	1	-	-	-	-	-	-
Potassium Phosphate	Colorless to white Crystal	1	-	-	1	-	-	-	1	-	1	1	-	-	-	-	-	-	-	-	-
Potassium Silicate, Other Than Dry	-	1	1	-	1	1	2	-	1	-	1	-	-	-	-	-	-	-	-	-	-
Potassium Sulfate	White Crystal or Powder	1	-	-	-	-	-	-	-	-	-	1	1	1	-	-	-	-	-	-	-
Potassium Sulfide	Red or yellow Crystal or Solid	1	1	-	1	1	-	-	1	1	1	2	-	-	-	-	-	-	-	-	-
Potassium Sulfite	White Crystal or Powder	1	-	-	-	-	-	-	-	-	-	1	-	2	-	-	-	-	-	-	-
Potassium Thiosulfate	Colorless crystal	1	-	-	1	-	-	-	1	-	1	1	-	1	-	-	-	-	-	-	-
Primatol A, S, P (Ag Spray)	Liquid	1	-	-	-	-	-	-	-	-	-	-	-	-	-	-	-	-	-	-	-
Propane Gas	Colorless Gas	CONTACT DENVER PRODUCT APPLICATION													-	-	-	-	-	-	-
Propanediol	Colorless Liquid	1	1	-	1	1	-	-	X	1	1	2	-	-	-	-	-	-	-	-	-
Propanol (Propyl Alcohol)	Colorless Liquid	1	1	1	1	-	-	-	-	1	1	-	1	1	2	-	-	-	-	-	-
Propionic Acid	Colorless Oily Liquid	1	1	1	2	X	2	2	X	2	1	2	-	-	-	1	1	-	-	-	-
Propyl Acetate	Colorless Liquid	1	1	1	-	-	-	-	-	X	-	2	-	-	-	-	-	-	-	-	-
Propyl Alcohol (Propanol)	Colorless Liquid	1	1	1	1	-	-	-	-	1	1	-	1	1	2	-	-	-	-	-	-
Propyl Aldehyde	White-water Liquid	1	-	-	-	X	-	X	-	2	X	X	-	-	-	-	-	-	-	-	-
Propyl Chloride	Colorless Liquid	1	-	-	-	X	-	X	-	X	2	X	-	-	-	-	-	-	-	-	-
Propylene	Colorless Gas	1	-	-	X	X	X	X	X	X	1	X	-	-	-	-	-	-	-	-	-
Propylene Diamine	Colorless Liquid	1	-	-	-	2	-	2	-	2	-	X	-	-	-	-	-	-	-	-	-
Propylene Dichloride (Dichloropropane)	Colorless Liquid	1	-	-	X	X	X	X	X	X	2	X	-	-	-	-	-	-	-	-	-
Propylene Glycol	Liquid	1	1	-	1	1	1	1	1	1	1	1	1	2	1	-	-	-	-	-	-
Propylene Oxide	Colorless Liquid	-	-	-	-	-	-	-	-	1	-	-	-	-	-	-	-	-	-	-	-
Purina Insecticide	-	1	1	-	2	X	-	-	X	2	2	-	-	2	-	1	1	1	1	2	-
Puropale RX Oils	Liquid	1	1	-	X	1	-	-	X	-	-	-	1	2	1	1	1	1	1	1	-
Pydraul 10E, 29E-LT, 30E, 60, 65E, 1155E	Liquid	1	1	-	2	X	-	-	-	2	-	-	2	-	X	1	1	1	1	1	-
Pydraul 135	Liquid	1	1	-	-	X	-	-	-	2	1	-	2	2	-	1	1	1	-	-	-
Pydraul 150	Liquid	1	1	-	2	X	X	X	X	2	1	X	2	2	X	1	1	1	1	1	-
Pydraul 280	Liquid	1	1	-	2	X	X	X	X	2	2	X	2	2	X	1	1	1	-	-	-
Pydraul 312	Liquid	1	1	-	X	X	X	X	X	X	1	-	2	1	X	1	1	1	-	-	-
Pydraul 50E	Liquid	1	1	-	2	-	-	-	-	2	2	-	2	1	X	-	-	-	-	-	-
Pydraul 540	Liquid	1	1	-	X	X	X	X	X	X	1	X	2	X	X	1	1	1	-	-	-
Pydraul 625	Liquid	1	1	-	2	X	X	X	X	2	1	X	2	2	X	1	1	1	-	-	-
Pydraul A-200	Liquid	1	1	-	X	X	X	X	X	X	1	X	2	2	X	1	1	1	-	-	-
Pydraul F-9	Liquid	1	2	-	2	X	X	X	X	2	1	X	2	2	-	1	1	1	-	-	-
Pyrene (Carbon Tetrachloride)	Colorless Liquid	1	2	X	X	X	X	X	X	X	1	X	2	1	X	X	2	2	X	2	X
Pyrethrum	Liquid	1	-	-	-	-	-	-	-	-	-	-	-	-	2	-	-	-	-	-	-
Pyridine (50%)	-	1	2	-	-	-	-	-	X	-	X	X	-	X	-	1	1	1	1	1	-
Pyrogard 160, 230, 630	Liquid	1	1	-	-	-	-	-	-	-	2	-	-	-	-	1	1	1	-	-	-
Pyrogard 51, 53, 55	Liquid	1	1	-	2	X	-	-	-	2	-	-	-	-	-	1	1	1	-	-	-

Chemical	Form (at room temperature unless otherwise stated)	Gates Hose / Polymers														Couplings / Adapters					
		Teflon®	XLPE	UHMWPE	EPDM	NBR	SBR	NR	CR	Butyl	Fluorocarbon	Hypalon®	CPE	Nylon	PVC	Iron/Carbon Steel	Stainless Steel 304	Stainless Steel 316	Aluminum	Brass	Polypro
Pyrogard C, D	Liquid	1	1	-	X	1	-	-	-	X	-	-	1	2	1	1	1	1	1	-	-
Pyronal (Transformer Oil)	Liquid	1	1	-	-	-	-	-	-	-	1	-	-	-	-	-	-	-	-	-	-
Q																					
Quenching Oil	Liquid	1	-	-	-	2	-	-	-	2	-	-	-	-	-	-	1	1	1	-	-
Quintolubric 822	Liquid	1	1	-	2	1	-	-	-	2	X	1	-	-	1	-	1	1	1	1	-
R																					
Ramrod (Ag Spray)	-	1	1	-	-	-	-	-	-	-	-	-	-	1	-	1	1	1	1	1	-
Rando Oils	Liquid	1	1	-	X	1	-	-	-	X	-	-	1	-	1	1	1	1	1	1	-
Rape Seed Oil	Brownish to yellow Liquid	1	1	-	2	-	-	-	-	2	-	X	-	2	-	1	1	1	1	1	-
Red Oil (Commercial Oleic Acid) (MIL-5606)	Liquid	1	2	2	2	2	X	X	2	2	2	X	2	1	2	2	2	1	1	2	1
Refined Wax (Petroleum)	-	1	1	-	-	1	X	X	2	-	1	-	1	-	1	1	1	-	1	-	-
Regal Oils R&O	Liquid	1	1	-	X	1	-	-	-	X	-	-	1	2	1	1	1	1	1	1	-
Richfield "A" Weed Killer	-	1	1	-	X	2	X	X	X	X	2	X	-	2	-	-	-	-	-	-	-
Road Paving Compound	-	-	-	X	-	-	-	-	-	-	-	-	-	-	-	-	-	-	-	-	-
Road Tar	-	-	-	2	-	-	-	-	-	-	-	-	-	-	-	-	-	-	-	-	-
Rubilene Oils	Liquid	1	1	-	X	1	-	-	-	X	-	-	1	2	-	-	-	-	-	-	-
S																					
Salicylic Acid	White Powder	1	1	1	2	X	2	2	-	2	2	-	-	1	1	-	1	1	2	-	-
Salt Water (Sea Water)	Liquid	1	1	-	1	2	2	X	2	1	1	2	-	1	1	2	1	1	-	2	-
Sauerkraut	-	1	-	-	-	-	-	-	-	-	-	-	-	2	-	-	-	-	-	-	-
Sea Water	Colorless Liquid	1	1	-	1	2	2	X	2	1	1	2	-	1	1	2	1	1	-	2	-
Sevin	-	1	2	-	2	-	-	-	-	-	-	-	-	1	-	-	-	-	-	-	-
Sewage	Sludge	1	1	1	1	2	2	X	2	-	-	2	1	1	2	X	1	1	2	1	-
Shampoo	Liquid	1	-	1	-	-	-	-	-	-	-	-	-	-	-	-	-	-	-	-	-
Shellac	Orange to colorless flake	1	-	X	-	-	-	-	-	-	-	-	-	1	-	-	-	-	-	-	-
Shortening	-	1	-	-	X	1	-	-	-	-	-	-	-	-	-	-	-	-	-	-	-
Silicate of Soda	Brownish or yellow Liquid	1	1	-	1	1	-	1	1	1	1	1	-	-	-	-	-	-	-	-	-
Silicone Greases	Liquid	1	2	-	-	2	-	-	2	-	2	2	-	1	2	1	1	1	-	1	-
Silicone Oils	Liquid	1	2	-	-	2	-	-	2	-	2	2	-	1	2	1	1	1	-	1	-
Silver Cyanide	White Powder	1	1	-	-	-	-	1	-	-	-	-	-	1	-	-	-	-	-	1	-
Silver Nitrate	Colorless crystal	1	1	-	1	1	1	1	1	1	1	1	1	1	2	2	1	1	1	2	-
Skydrol 500A & 7000	Liquid	1	1	-	1	X	X	X	X	2	X	X	2	1	X	1	1	1	1	-	-
Soap Oil	Liquid	1	1	2	-	X	-	-	X	-	-	X	-	-	1	1	1	-	-	-	-
Soap Solutions	Liquid	1	1	1	1	1	X	X	2	1	1	1	1	1	1	1	1	1	1	1	-
Soap, Liquid	Liquid	1	1	-	1	1	2	2	1	2	1	1	-	2	2	1	1	1	-	-	-
Soda Ash (Sodium Carbonate)	Grayish Powder	1	1	-	1	1	1	1	1	1	1	1	1	1	1	1	1	1	1	X	2
Soda Water	Liquid	1	-	-	-	-	-	-	-	-	-	-	-	1	1	-	-	-	-	-	-
Sodium Acetate	Colorless crystal	1	1	-	2	X	2	2	X	2	X	X	1	1	1	1	1	1	1	1	-
Sodium Aluminate Solution	Colorless to cloudy Liquid	1	1	-	1	1	2	2	1	1	1	1	-	2	2	-	-	-	-	-	-
Sodium Benzoate	White Crystals or Powder	1	-	-	-	-	-	-	-	-	-	-	-	1	-	-	-	-	-	1	-
Sodium Bicarbonate	White Crystal or Powder	1	1	-	1	1	1	1	1	1	1	1	1	1	1	2	1	1	-	2	-
Sodium Bichromate Solution	Red to clear Liquid	1	1	-	1	2	2	2	2	1	1	2	-	2	2	-	-	-	-	-	-
Sodium Bisulfate (Niter Cake)	Colorless Crystals to White Lumps	1	1	-	1	1	1	1	1	1	1	1	1	1	1	X	1	1	X	X	-
Sodium Bisulfite	White Crystals or Powder	1	1	-	1	1	1	1	1	1	1	1	1	1	1	1	1	1	-	-	-
Sodium Borate (Borax)	White Crystals	1	1	-	1	1	1	1	1	1	1	1	1	1	1	2	1	1	-	2	1
Sodium Carbonate (Soda Ash)	Grayish Powder	1	1	-	1	1	1	1	1	1	1	1	1	1	1	1	1	1	X	2	1
Sodium Chlorate	Colorless Crystals	1	-	-	1	1	1	2	2	1	1	-	1	1	-	-	-	-	-	1	-
Sodium Chloride	Colorless to white Crystals	1	1	1	1	1	1	1	1	1	1	1	1	1	1	2	1	1	X	X	-
Sodium Chlorite Solution	Colorless to cloudy Liquid	2	-	-	X	X	2	2	X	2	X	2	-	X	2	-	-	-	-	-	-
Sodium Chromate	Yellow, translucent Crystals	1	-	-	-	1	2	2	1	2	1	X	-	2	2	-	-	-	-	-	-
Sodium Cyanide	In Water	1	1	-	1	1	1	1	1	1	1	1	1	1	1	2	1	1	X	X	-
Sodium Cyanide	White Crystalline Powder	1	1	-	1	1	1	1	1	1	1	1	1	1	1	2	1	1	X	X	-

CHEMICAL RESISTANCE TABLE

THE WORLD OF HOSE

Chemical	Form (at room temperature unless otherwise stated)	Gates Hose / Polymers													Couplings / Adapters						
		Teflon®	XLPE	UHMWPE	EPDM	NBR	SBR	NR	CR	Butyl	Fluorocarbon	Hypalon®	CPE	Nylon	PVC	Iron/Carbon Steel	Stainless Steel 304	Stainless Steel 316	Aluminum	Brass	Polypro
Sodium Dichromate	Red to red-orange Crystals	1	-	-	1	1	2	2	2	1	1	2	1	-	1	-	-	-	-	-	1
Sodium Ferricyanide	Ruby-red Crystals	1	-	-	-	-	-	-	-	-	-	-	-	-	1	-	-	-	-	-	1
Sodium Ferrocyanide	Yellow, transparent Crystals	1	-	-	-	-	-	-	-	-	-	-	-	-	1	-	-	-	-	-	1
Sodium Fluoride (70%)	White Liquid	1	1	1	2	-	2	2	-	2	-	-	-	-	1	-	-	2	-	-	-
Sodium Hydrate	White Solid	1	2	-	1	2	2	2	2	2	2	2	-	2	2	-	-	-	-	-	-
Sodium Hydrochlorite	Pale greenish Liquid	1	2	-	2	X	2	X	X	2	1	1	-	2	2	-	-	-	-	-	-
Sodium Hydrosulfide	Colorless needles	1	-	-	-	-	-	-	-	-	-	-	-	-	1	-	-	-	-	-	-
Sodium Hydrosulfite	Lemon colored Powder or flake	1	-	-	-	-	-	-	-	-	-	-	-	-	2	-	-	-	-	-	-
Sodium Hydroxide (10%)	Colorless Liquid	1	1	1	-	-	-	-	-	-	1	-	1	-	-	-	-	-	-	-	-
Sodium Hydroxide (40%)	Colorless Liquid	1	1	1	2	2	1	1	1	2	1	1	1	X	-	2	1	1	X	X	-
Sodium Hydroxide (50% Under 212°F (100°C))	Colorless Liquid	1	1	2	2	-	-	-	-	-	X	-	-	-	-	-	-	-	-	-	-
Sodium Hydroxide (50%, Under 115°F (44°C))	Colorless Liquid	1	1	2	2	X	1	1	2	1	X	1	1	X	-	2	2	2	X	X	-
Sodium Hydroxide (50%, Under 180°F (82°C))	Colorless Liquid	1	1	2	2	X	X	X	2	2	X	2	1	X	-	X	2	2	X	X	-
Sodium Hydroxide (60%)	White Liquid	1	2	1	2	X	2	2	2	2	X	2	1	X	-	X	2	2	X	X	-
Sodium Hydroxide 25%	Colorless Liquid	1	1	1	2	2	1	1	1	2	1	1	X	-	-	X	X	2	X	X	-
Sodium Hypochlorite (20%)	White Liquid	1	2	1	1	X	X	X	X	-	X	1	1	2	1	X	X	2	X	X	-
Sodium Hypochlorite (5%)	White Liquid	1	2	1	1	X	X	X	-	-	1	1	1	1	1	X	X	2	X	X	-
Sodium Hyposulfate	Large, transparent Crystals	1	-	-	-	-	-	-	-	-	-	-	-	-	1	-	-	-	-	-	-
Sodium Metallic	Silver Solid	2	-	-	1	2	-	-	-	-	-	-	-	-	-	-	-	-	-	-	-
Sodium Metaphosphate	Colorless Crystals to white Powder	1	1	-	2	2	2	2	2	2	2	2	1	1	1	X	1	1	1	X	-
Sodium Nitrate	Colorless crystal	1	1	-	2	X	X	X	X	2	-	2	1	1	1	1	2	2	2	2	-
Sodium Perborate	White, amorphous Powder	1	1	-	2	X	X	X	X	2	-	X	-	2	-	X	1	1	1	X	-
Sodium Peroxide	Yellowish white Powder	1	1	2	-	-	-	-	-	1	1	1	2	X	1	X	1	1	1	X	-
Sodium Phosphate	Colorless Crystals to white Powder	1	1	-	2	-	2	2	X	2	-	-	1	1	1	-	1	1	X	X	-
Sodium Silicate	Lumps of greenish glass	1	1	-	1	1	1	1	1	1	1	1	1	1	1	-	-	-	-	-	1
Sodium Sulfate	White Crystals or Powder	1	1	-	1	1	2	2	1	1	1	1	1	1	1	-	-	-	-	-	1
Sodium Sulfate Decahydrate (Glauber's Salt)	Crystals or Powder	1	-	-	1	-	1	1	-	-	-	-	-	-	-	-	-	-	-	-	-
Sodium Sulfhydrate	Colorless to cloudy Liquid	1	2	-	1	2	X	2	2	2	2	2	-	2	2	-	-	-	-	-	-
Sodium Sulfide	Yellow/Brick red flakes or Crystals	1	1	-	1	1	2	2	1	1	1	1	1	1	1	-	-	-	-	-	1
Sodium Sulfide Solution	Colorless to cloudy Liquid	1	2	-	1	2	-	2	2	1	2	2	-	X	-	-	-	-	-	-	1
Sodium Sulfite	White Crystals or Powder	1	1	-	2	2	2	2	2	2	-	2	1	1	1	1	1	1	-	-	-
Sodium Sulfite Solution	Colorless to cloudy Liquid	1	2	-	1	2	-	2	2	1	2	2	-	X	-	1	1	1	-	-	-
Sodium Sulphhydrate	Colorless needles	1	2	-	1	2	-	-	2	1	2	2	-	2	2	-	-	-	-	-	-
Sodium Thiocyanate Solution	Colorless to cloudy Liquid	1	1	-	1	2	-	1	2	1	2	-	-	-	-	-	-	-	-	-	-
Sodium Thiosulfate (HPO)	White Powder	1	1	-	-	1	1	1	1	1	-	1	1	1	1	X	1	1	2	X	-
Sodium Tripolyphosphate (STPP)	White Powder	1	2	-	-	-	-	-	2	X	-	-	-	-	-	-	1	1	X	X	-
Solnus Oils	Liquid	1	1	-	X	1	-	-	-	X	-	-	-	1	1	1	1	1	1	1	-
Sour Crude Oil	Liquid	-	-	-	-	-	-	-	-	-	-	-	-	-	X	-	-	-	-	-	-
Soybean Oil	Pale yellow oil	1	1	1	X	2	X	X	2	2	1	2	-	1	2	1	1	1	-	-	-
Spent Acid	Liquid	1	2	2	X	X	X	X	X	X	1	2	X	X	X	-	1	1	-	-	-
Stannic Chloride	Colorless, fuming Liquid	1	1	-	-	2	2	2	X	X	1	X	1	X	2	X	-	-	-	X	-
Stannic Sulfide	Yellow to brown Powder	1	2	-	-	2	-	2	-	2	-	2	-	-	-	-	-	-	-	-	-
Stannous Chloride (Under 150°F)	White Mass	1	1	-	2	1	1	1	1	1	1	1	1	X	1	-	-	-	-	-	1
Starch	White amorphous Powder	1	1	-	1	2	1	1	2	-	1	1	-	1	1	-	-	-	-	-	-
Starch gum (Dextrin)	Yellow or White Powder	1	1	-	1	1	-	-	1	X	1	-	-	1	1	-	1	1	-	-	1
Stauffer Jet 1	Liquid	1	1	-	-	-	-	-	-	-	-	-	-	-	-	1	1	1	1	1	-
Stauffer Jet 2	Liquid	1	1	-	-	-	-	-	-	-	-	-	-	-	-	1	1	1	1	1	-
Steam	Gas	USE STEAM HOSE ONLY																			
Stearic Acid (Octadecanoic Acid)	Colorless Waxy Solid	1	1	1	2	2	2	2	2	2	1	2	1	1	1	X	2	1	X	X	-
Stearin	Colorless crystal or Powder	1	-	-	-	-	-	-	-	-	-	-	-	-	2	-	-	-	-	-	-
Stoddard Solvent	Clear petroleum distillate	1	2	-	X	2	X	X	-	X	1	-	1	1	2	2	1	1	-	1	-
STPP (Sodium Tripolyphosphate)	White Powder	1	2	-	2	-	2	2	-	2	X	-	-	-	-	-	2	1	X	X	-

Chemical	Form (at room temperature unless otherwise stated)	Gates Hose / Polymers														Couplings / Adapters					
		Teflon®	XLPE	UHMWPE	EPDM	NBR	SBR	NR	CR	Butyl	Fluorocarbon	Hypalon®	CPE	Nylon	PVC	Iron/Carbon Steel	Stainless Steel 304	Stainless Steel 316	Aluminum	Brass	Polypro
Straight Synthetic Oils	Liquid	1	-	-	-	-	-	-	-	-	-	-	-	1	2	-	-	-	-	-	-
Styrene (Monomer)	Colorless Oily Liquid	1	2	-	X	X	X	X	-	X	2	-	2	2	-	2	X	2	X	2	-
Sucrose Solutions	Liquid	1	1	-	-	1	1	1	1	1	-	1	-	-	-	1	1	1	-	-	-
Sugar, Liquid, Blended	Liquid	1	1	-	1	1	1	1	1	1	1	2	-	-	-	-	-	-	-	-	-
Sugar, Syrup	Liquid	1	1	-	1	1	1	1	1	1	1	2	-	-	-	-	-	-	-	-	-
Sulfamic Acid	In Water	1	1	1	2	X	X	X	-	2	1	2	1	X	X	-	-	-	-	-	-
Sulfamic Acid 10% Under 170°F (77°C)	Colorless Liquid	1	X	-	-	-	X	X	-	2	2	1	-	-	-	-	-	-	-	-	-
Sulfate Liquors Under 150°F (66°C)	-	1	-	-	-	-	-	-	-	-	-	-	-	1	1	-	-	-	-	-	1
Sulfur (Under 200°F (93°C))	Yellow Crystals	-	-	-	-	-	-	-	-	-	-	-	-	-	-	-	-	-	-	-	-
Sulfur Chloride	Yellow Oily Liquid	1	2	-	X	X	X	X	X	X	1	2	-	2	2	X	X	2	-	X	-
Sulfur Dioxide	Colorless Gas or Liquid	-	-	-	2	X	X	-	-	2	X	-	-	-	-	-	-	-	-	-	-
Sulfur Dioxide (Dry)	-	1	2	-	2	X	X	X	X	X	1	2	-	X	1	2	1	1	1	1	-
Sulfur Dioxide (Liquid)	Colorless Liquid	1	-	1	1	X	X	X	2	2	X	2	-	-	X	-	-	-	-	-	-
Sulfur Dioxide (Moist)	-	1	-	1	1	X	X	X	2	1	2	2	-	-	X	-	-	-	-	-	-
Sulfur Hexafluoride (Gas)	Colorless Gas	1	1	-	1	2	2	2	1	1	2	2	-	1	2	-	-	-	-	-	-
Sulfur Trioxide (Dry)	Solid	1	2	-	2	X	X	X	X	X	1	X	X	-	1	2	2	2	2	-	-
Sulfuric Acid (10%)	Colorless Water Solution	1	1	1	1	2	1	1	1	1	1	1	1	X	-	X	X	2	X	X	-
Sulfuric Acid (100%)	Colorless Liquid	1	X	X	X	X	X	X	X	X	2	X	X	-	-	2	X	2	X	X	-
Sulfuric Acid (30%)	Colorless Water Solution	1	1	1	1	2	2	2	1	1	1	1	1	X	-	X	X	2	X	X	-
Sulfuric Acid (50%)	Colorless Water Solution	1	1	1	1	X	X	X	2	1	1	1	1	X	-	X	X	2	X	X	-
Sulfuric Acid (60%) (48.5 deg Baume)	Colorless Liquid	1	1	1	1	X	X	X	X	1	1	1	1	X	-	X	X	2	X	X	-
Sulfuric Acid (75%)	Colorless to Brown Solution	1	1	1	2	X	X	X	X	2	1	2	2	X	-	X	X	2	X	X	-
Sulfuric Acid (88%) (64.7 deg Baume)	Colorless Liquid	1	2	1	X	X	X	X	X	X	1	X	X	X	-	X	X	2	X	X	-
Sulfuric Acid (93%)	Colorless to Brown Oily Liquid	1	X	1	X	X	X	X	X	X	1	X	X	X	-	X	X	2	X	X	-
Sulfuric Acid (96%)	Colorless Liquid	1	X	1	X	X	X	X	X	X	1	X	X	X	-	X	X	2	X	X	-
Sulfuric Acid (98%)	Colorless to Brown Oily Liquid	1	X	1	X	X	X	X	X	X	1	X	X	X	-	X	X	2	X	X	-
Sulfuric Acid, Fuming (Oleum)	Colorless to Dark Brown Oily Liquid	1	X	X	X	X	X	X	X	X	1	X	X	X	-	-	1	-	-	X	-
Sulfurous Acid (10%)	Colorless Liquid	1	1	1	1	X	X	X	-	2	1	1	1	-	-	X	2	1	X	X	-
Sulfurous Acid (75%)	Colorless Liquid	1	1	1	1	X	X	X	X	X	1	1	1	X	-	X	X	2	X	X	-
Sun R&O Oils	Liquid	1	1	-	X	1	-	-	-	X	1	-	-	1	2	1	1	1	1	-	-
Suntac HP Oils	Liquid	1	1	-	X	1	-	-	-	X	1	-	-	1	2	1	1	1	1	-	-
Suntac WR Oils	Liquid	1	1	-	X	1	-	-	-	X	1	-	-	1	2	1	-	1	1	-	-
Sunvis Oils 700, 800, 900	Liquid	1	1	-	X	1	-	-	-	X	1	-	-	1	2	1	1	1	-	-	-
Synthetic Oil (Citgo)	Liquid	1	1	-	X	-	-	-	-	X	-	-	-	1	2	1	1	1	-	-	-
Syrup	Viscous Liquid	1	1	-	-	-	-	1	1	2	-	1	-	-	-	-	1	1	-	-	-
T																					
Tall Oil	Black liquid	1	2	-	X	1	X	X	X	X	2	X	-	-	X	-	X	2	-	-	-
Tall Oil(Under 150°F (66°C))	Liquid	1	1	-	X	2	X	X	2	X	1	X	-	-	-	-	X	2	-	-	-
Tallow	White to clear Solid or Liquid	1	1	-	2	2	-	-	2	2	-	-	-	1	2	2	2	2	1	2	-
Tannic Acid	Faint Yellow Powder	1	1	1	1	X	2	2	2	1	1	2	1	1	1	2	1	1	2	X	-
Tannic Acid (10%)	Yellow Liquid	1	1	-	-	X	2	2	2	X	1	2	1	1	1	2	1	1	2	X	-
Tar (Bituminous) Under 100°F (38°C)	-	1	1	2	X	2	X	X	2	X	1	-	X	-	-	1	1	1	1	1	2
Tar Oil	Yellow to dark brown Liquid	1	-	-	-	-	-	-	-	-	-	-	-	-	1	2	-	-	-	-	-
Tartaric Acid	White Crystalline Powder	1	1	1	1	2	2	2	2	1	1	1	1	-	-	-	2	2	2	-	-
TEA (Triethanolamine)	Colorless Viscous Liquid	1	1	-	1	2	2	2	2	2	X	2	1	-	2	-	1	1	-	1	-
TEL (Tetraethyl Lead)	Colorless Oily Liquid	1	2	-	X	2	X	X	X	X	1	X	-	2	1	-	-	-	-	-	-
Tellus Oils	Liquid	1	1	-	X	1	-	-	-	X	1	-	-	1	2	1	1	1	1	1	-
Tenol Oils	Liquid	1	1	-	X	1	-	-	-	X	1	-	-	1	2	1	1	1	1	-	-
Tergitol (Ethoxylates and Ethoxysulfates of Alcohol)	-	1	2	-	-	-	-	-	-	-	-	-	-	-	-	-	2	1	1	-	2
Terpineol	Colorless Liquid or Crystal	1	1	-	-	-	X	X	-	X	-	2	1	2	2	-	-	-	-	-	-
Tertiary Butyl Alcohol	Colorless Liquid or Crystal	1	2	-	-	2	-	-	-	-	1	-	-	-	-	-	-	-	-	-	-
Tetrachlorobenzene	White Crystal	1	-	-	-	-	-	-	-	-	2	-	-	-	-	-	-	-	-	-	-

CHEMICAL RESISTANCE TABLE

THE WORLD OF HOSE

Chemical	Form (at room temperature unless otherwise stated)	Gates Hose / Polymers													Couplings / Adapters						
		Teflon®	XLPE	UHMWPE	EPDM	NBR	SBR	NR	CR	Butyl	Fluorocarbon	Hypalon®	CPE	Nylon	PVC	Iron/Carbon Steel	Stainless Steel 304	Stainless Steel 316	Aluminum	Brass	Polypro
Tetrachloroethane (Acetylene Tetrachloride)	Colorless Liquid	1	X	X	X	-	X	X	-	X	1	X	X	1	X	-	-	-	-	-	-
Tetrachloroethylene	Colorless Liquid	1	-	-	-	-	-	-	-	-	1	-	-	-	-	-	-	-	-	-	-
Tetrachloromethane	Colorless Liquid	1	-	-	-	-	-	-	-	-	1	-	-	-	-	-	-	-	-	-	-
Tetrachloronaphthalene	Oily Liquid to Crystalline Solid	1	-	-	-	-	-	-	-	-	2	-	-	-	-	-	-	-	-	-	-
Tetradecanol	White Solid	1	-	-	-	-	-	-	-	-	-	-	-	-	-	-	-	-	-	-	-
Tetraethyl Lead (TEL)	Colorless Oily Liquid	1	2	-	X	2	X	X	X	X	1	X	-	2	1	-	-	-	-	-	-
Tetraethylene Glycol	Colorless Liquid	1	2	-	-	2	-	2	-	1	2	2	-	-	-	-	-	-	-	-	-
Tetrahydrofuran (THF)	Colorless Liquid	1	X	-	2	X	X	X	X	2	1	X	-	1	X	2	-	-	-	-	X
Tetrahydroxycyclopentadiene (JP 10) ²	-	-	-	-	X	X	X	X	X	X	1	X	-	1	X	-	-	-	-	-	-
Tetralin	Colorless Liquid	1	-	-	X	X	X	X	X	X	1	X	-	2	-	-	-	-	-	-	X
Theobromo Oil (Cocoa Butter)	Liquid above 95°F (35°C)	1	1	2	-	2	X	X	2	-	-	-	-	-	1	1	1	-	-	-	-
THF (Tetrahydrofuran)	Colorless Liquid	1	X	-	2	X	X	X	X	2	1	X	-	1	X	2	-	-	-	-	X
Thiopen	-	1	-	-	X	X	X	X	X	2	2	-	-	-	-	-	-	-	-	-	-
Tin Tetrachloride	Colorless Liquid	1	-	-	-	2	-	2	X	-	-	2	-	-	-	-	-	-	-	-	-
Titanium Tetrachloride	Colorless Liquid	1	-	-	X	X	-	-	X	X	2	-	-	-	-	1	2	2	X	X	-
Toluene (Toluol) (Methyl Benzene)	Colorless Liquid	1	2	2	X	X	X	X	X	X	1	X	X	1	X	1	1	1	1	1	-
Toluene Diisocyanate (Hylene)	Yellow Liquid	1	-	-	2	X	X	X	X	2	X	X	-	-	-	-	-	-	-	-	-
Toluene Diisocyanate (Isocyanate)	Water White to Yellow Liquid	1	2	-	X	X	X	X	X	X	1	-	-	-	-	1	1	1	-	-	-
Toluidine	Yellow Liquid or White Crystal	1	-	-	-	X	-	X	-	X	2	X	-	-	-	-	-	-	-	-	-
Toluol (Toluene)	Colorless Liquid	1	2	2	X	X	X	X	X	X	1	X	X	1	X	1	1	1	1	1	-
Transformer Oil (Askarel Types)1	Liquid	1	2	2	X	X	X	X	X	X	1	X	1	1	X	1	1	1	-	1	2
Transformer Oil (Petroleum Type)1	Liquid	1	1	-	X	1	X	X	2	X	1	X	1	1	2	1	1	1	1	1	-
Transmission Fluid (Type A)	Liquid	1	1	-	X	1	X	X	2	X	1	-	1	2	-	1	1	1	-	1	-
Tributoxyethyl Phosphate	Yellow Liquid	1	1	X	2	X	X	X	-	2	-	X	X	2	-	1	-	-	X	-	-
Tributyl Phosphate	Colorless Liquid	1	1	X	X	X	X	X	X	X	1	X	2	-	-	1	-	-	X	-	-
Tricalcium Aluminate (Calcium Aluminate)	Crystals or Powder	1	-	-	-	-	-	1	-	-	-	-	-	-	-	-	-	-	-	-	-
Trichlorobenzene	White Crystal or colorless Liquid	1	2	-	-	X	X	X	X	2	X	-	-	-	-	-	-	-	-	-	-
Trichloroethane 1,1,1 (Methyl Chloroform)	Colorless Liquid	1	X	-	X	X	X	X	X	X	1	X	X	X	-	-	-	-	-	-	-
Trichloroethylene	Colorless Liquid	1	1	X	X	X	X	X	X	X	1	X	2	2	-	X	-	1	X	1	-
Trichloropropane	Colorless Liquid	1	-	-	-	2	-	X	2	X	1	X	-	-	-	-	-	-	-	-	-
Tricresyl Phosphate	Colorless Liquid	1	-	X	1	X	X	X	X	2	1	X	1	1	-	1	-	2	X	-	-
Triethanolamine (TEA)	Colorless Viscous Liquid	1	1	-	1	2	2	2	2	2	X	2	1	-	2	-	1	1	-	1	-
Triethylamine	Colorless Liquid	1	-	-	2	2	X	X	-	X	2	-	-	-	-	-	-	-	-	-	-
Triethylene Glycol	Colorless Liquid	1	-	-	-	2	-	2	-	2	2	2	-	-	-	-	-	-	-	-	-
Trihydroxybenzoic Acid (Gallic Acid)	In Alcohol or Glycerol	1	1	1	1	X	2	2	X	2	1	-	1	X	X	X	1	1	-	-	1
Trimethyl Phosphate	Colorless Liquid	-	-	X	-	-	-	-	-	-	-	-	-	-	-	-	-	-	-	-	-
Trimethylbenzene (Mesitylene)	Liquid	1	-	-	X	X	X	X	X	X	1	-	-	1	X	-	-	-	-	-	-
Trinitrophenol (Picric Acid)	Yellow Crystals	1	2	2	2	2	2	2	2	2	1	2	-	X	1	X	1	1	X	X	1
Trioctyl Phosphate	Liquid	-	-	X	-	-	-	-	-	-	-	-	-	-	-	-	-	-	-	-	-
Triphenyl Phosphate	Colorless Powder	-	-	X	-	-	-	-	-	-	-	-	-	-	-	-	-	-	-	-	-
Tripolyphosphate (STPP), (Sodium)	White Powder	1	2	-	2	-	2	2	-	2	X	-	-	-	-	2	1	X	X	-	-
Trisodium Phosphate (TSP)	Colorless crystal	1	-	-	1	2	2	X	2	2	1	X	-	-	-	-	-	-	-	-	-
Tung Oil	Yellow drying oil	1	2	-	X	2	X	X	X	X	1	2	-	-	2	1	1	1	1	1	-
Turpentine	Liquid oil	1	X	1	X	2	X	X	X	X	1	X	2	1	1	-	1	1	1	2	-
U																					
Ucon Hydrolube Types 150CP, 200CP	Liquid	1	1	-	1	1	-	-	-	1	-	-	-	1	2	1	1	1	1	1	-
Ucon Hydrolube Types 275CP, 300CP, 550CP	Liquid	1	-	-	-	1	X	X	-	X	1	-	-	2	2	-	-	-	-	-	-
Ucon M1	Liquid	1	1	-	1	1	-	-	-	-	1	-	-	-	1	2	1	1	1	1	1
Undecanol (Undecyl Alcohol)	Colorless Liquid	1	-	-	-	1	-	2	-	-	2	2	-	-	-	-	-	-	-	-	-
Undecyl Alcohol (Undecanol)	Colorless Liquid	1	-	-	-	1	-	2	-	-	2	2	-	-	-	-	-	-	-	-	-
Union Hydraulic Tractor Fluid	Brown Liquid	1	1	-	X	1	-	-	-	X	-	-	-	1	2	1	1	1	1	1	-
Urea Solution (100%)	Liquid	1	1	-	-	2	1	1	1	2	-	1	1	1	2	1	1	1	-	-	-

1 = Preferred - Constant Contact 2 = Acceptable - Intermittent Contact X = Not Recommended - = No Data NOTE: Ratings are for the affect on the polymer only!		Gates Hose / Polymers													Couplings / Adapters						
		Form (at room temperature unless otherwise stated)	Teflon®	XLPE	UHMWPE	EPDM	NBR	SBR	NR	CR	Butyl	Fluorocarbon	Hypalon®	CPE	Nylon	PVC	Iron/Carbon Steel	Stainless Steel 304	Stainless Steel 316	Aluminum	Brass
V																					
Varnish	-		1	2	-	X	X	X	X	X	2	X	-	1	-	2	1	1	-	2	-
Vegetable Oils	Liquids		1	-	1	2	-	X	X	2	X	-	1	1	1	2	1	1	1	1	-
Versilube F-50, F-44	Liquid		1	-	-	2	2	2	2	2	2	1	2	-	1	2	1	1	1	1	-
Vinegar	Brownish to colorless Liquid		1	1	-	-	2	2	2	2	2	1	X	2	-	1	X	2	1	X	X
Vinyl Acetate	Colorless Liquid		1	1	X	X	X	X	X	X	2	X	X	1	-	-	-	1	2	1	2
Vinyl Chloride (Monomer)	-		1	2	-	X	X	X	X	X	2	X	X	-	X	2	1	1	1	X	-
Vinyl Fluoride	Colorless Gas		1	1	-	-	-	-	-	-	1	-	-	-	-	-	-	-	-	-	-
Vinyl Trichloride (Trichloroethane)	Colorless Liquid		1	-	-	X	X	X	X	X	X	1	X	X	X	X	-	-	-	-	-
Vitrea Oils	Liquid		1	1	-	X	1	-	-	-	X	-	-	1	2	1	1	1	-	-	-
VM&P Naptha (Mineral Spirits)	Colorless Liquid		1	1	-	X	1	X	X	-	X	1	X	-	1	-	1	1	2	1	-
W																					
Waste Paint	Liquid to semi-Solid paste		1	-	-	-	-	-	-	-	-	-	-	-	-	-	-	-	-	-	-
Water	Liquid		1	1	1	1	1	1	1	1	1	-	1	1	1	1	2	1	1	1	1
Water (Brine)	Liquid		1	1	-	1	2	1	1	2	1	1	1	-	1	1	-	-	-	-	1
Water (Deionized)	Liquid		1	-	1	-	-	-	-	-	1	-	-	-	-	-	-	-	-	-	-
Water (Distilled)	Liquid		1	1	1	1	1	1	1	2	1	-	1	-	1	1	-	-	-	-	1
Water (Potable)	Liquid		USE AQUARIUS HOSE ONLY										1	-	-	-	-	-	1		
Water Glycols	Liquid		1	1	1	-	-	-	-	-	-	-	-	1	1	-	-	-	-	-	-
Water in Oil Emulsions	Liquid		1	1	1	-	-	-	-	-	-	-	-	1	1	-	-	-	-	-	-
White & Bagley No. 2190 Cutting Oil	Liquid		1	-	-	-	-	-	-	-	-	-	-	-	-	-	-	-	-	-	-
Wines	Liquid		1	2	-	X	X	X	X	X	X	1	X	1	1	-	2	2	2	1	-
Wood Oil	Liquid		1	1	-	X	1	X	X	2	X	1	2	1	1	1	-	-	-	-	-
X																					
Xylene (Dimethylbenzene)	Colorless Liquid		1	2	X	X	X	X	X	X	1	X	X	X	X	-	-	-	-	-	-
Xylenol (Dimethylphenol)	White solid, liquid @ 68°F [20°C]		1	1	-	-	-	-	-	-	1	-	-	-	-	-	-	-	-	-	-
Z																					
Zeric	-		1	1	-	X	1	-	-	-	X	-	-	-	2	2	-	-	-	-	-
Zinc Acetate	White Crystal		1	1	-	2	X	2	2	X	2	X	X	-	X	1	1	1	1	1	1
Zinc Chloride Solutions	Colorless to cloudy Liquid		1	1	-	-	1	2	2	1	2	1	1	1	1	2	X	2	1	X	X
Zinc Chromate	Yellow Solid		1	1	-	-	-	-	-	-	-	1	1	-	-	-	-	1	1	-	-
Zinc Hydrate	-		1	-	-	-	-	-	-	-	-	-	-	-	1	-	-	-	-	-	-
Zinc Oxide	White or gray Powder		1	-	-	-	-	-	-	-	-	-	-	-	1	-	-	-	-	-	-
Zinc Sulfate Solutions	Colorless to cloudy Liquid		1	1	-	2	2	X	X	2	2	-	2	1	2	2	X	2	1	X	X



INTEGRATED FLUID POWER SOLUTIONS

THE WORLD OF COUPLINGS

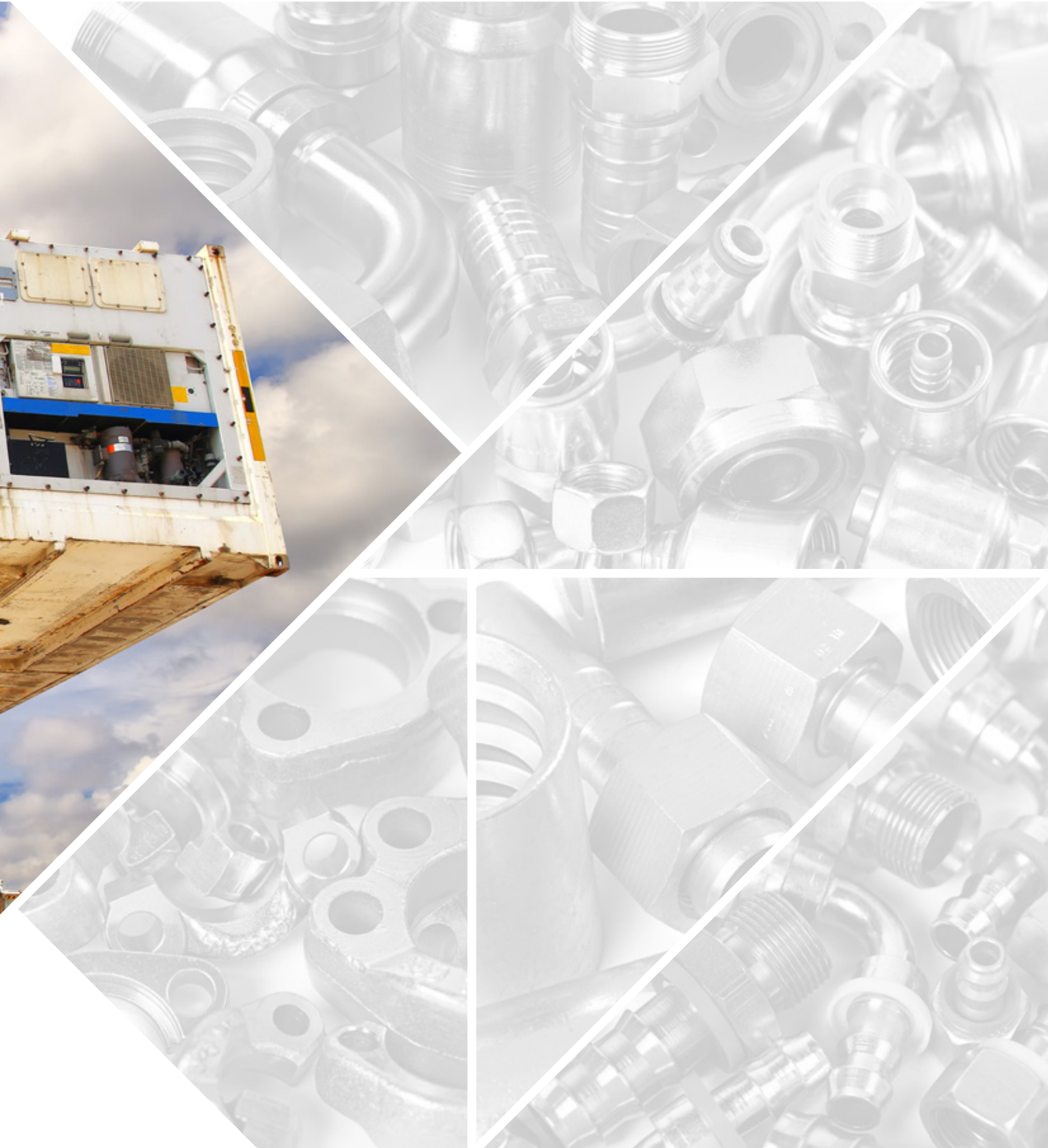

iLOK™ COUPLING

THE WORLD OF COUPLINGS

MAXIMISES OPERATION UPTIME

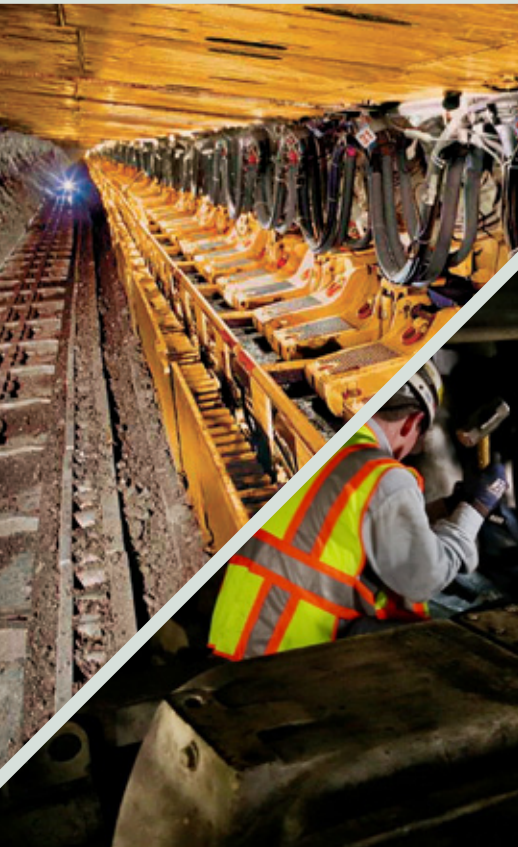

iLok™ is Gates' answer to the traditional staple-lock coupling, specifically designed to increase safety and substantially reduce downtime when disconnecting and reconnecting the coupling, a key challenge when moving and re-assembling in longwall mining.

Safe productivity

Circumstances in longwall mines are harsh on miners and equipment alike. Traditional staple couplings become deformed and corroded, making it extremely challenging to replace damaged hose assemblies or to disconnect roof shields. This often results in workers mistreating hoses and couplings, endangering themselves and the equipment. Gates helps you to improve both safety and productivity by introducing the new iLok™ coupling that retains the simplicity of staple-lock couplings but locks out the inherent limits of its design.

- › **Ease of use:** easy-to-understand design, quick to connect and disconnect by hand
- › **Safe disengagement:** helps to avoid dangerous disconnecting situations and dissipates residual pressure away from workers
- › **Time and labour savings:** reduces average disconnect time per coupling by up to 90%
- › **Robustness:** secure cable distributes forces along full length of flange area, no uneven staple stress or deformation
- › **Extended lifetime:** allows relative rotation to counter torsional stress on the hose assemblies between the self-advancing roof shields
- › **Compactness:** fits in virtually every corner. Abrasion or damage to nearby hoses is prevented by the absence of sharp ends of protruding staples.



Compared to a staple-lock coupling, iLok™ is safer and more efficient!

INNOVATION

A new coupling making longwall connections easier, faster and safer



Boosted durability with Gates TuffCoat™ Xtreme® plating

To further improve the lifetime of iLok™ couplings and adaptors in the highly corrosive mining environment, they are plated with Gates TuffCoat™ Xtreme®. This coating goes way beyond ISO 9227 standard requirements, offering 840 hours of red rust protection. Exactly what you need in extremely dusty and damp underground mining conditions.

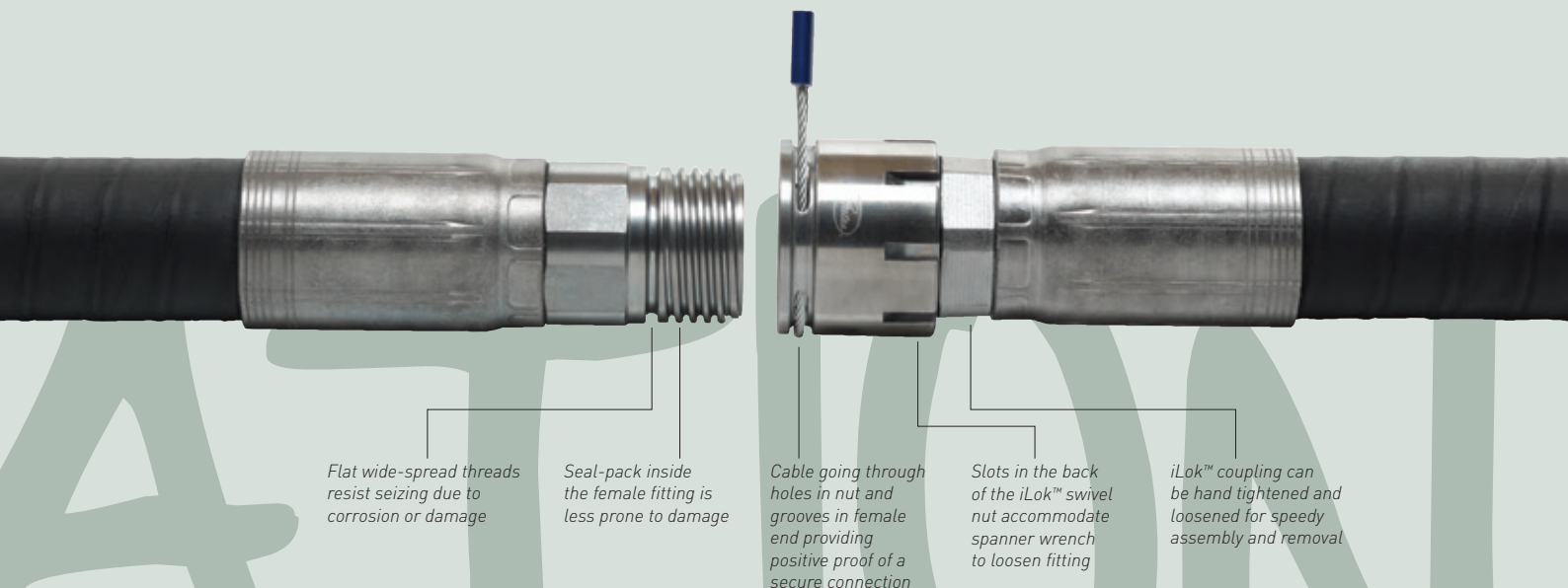



COUPLING SELECTION TABLE

THE WORLD OF COUPLINGS

COUPLINGS FOR WIRE SPIRAL HYDRAULIC HOSE

GlobalSpiral Maximum

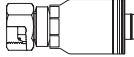
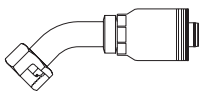
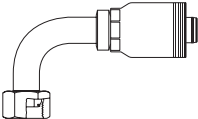
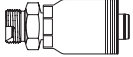
EFG6K (-24:-32), EFG5K (-24:-32) , EFG5KL (-24)

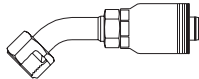
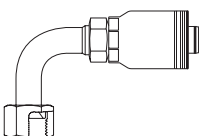
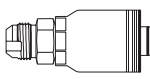
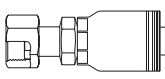
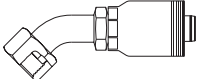
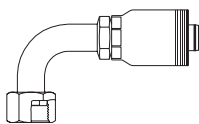
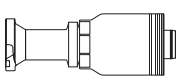
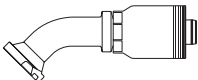
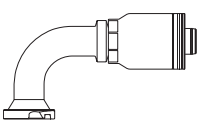
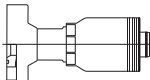
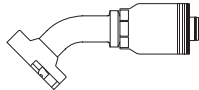
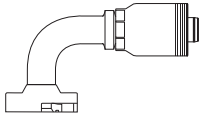
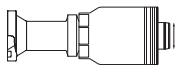
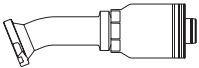
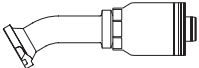
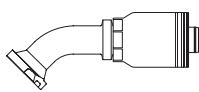
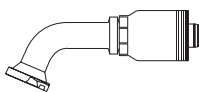
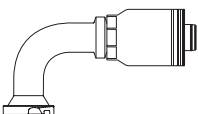
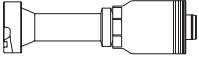
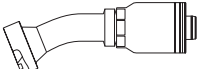
BSP				JIC
				
BSP FBSPORX p. 178	BSP FBSPORX45 p. 178	BSP FBSPORX90 p. 178	BSP MBSPP p. 179	JIC 37° FJX p. 179
JIC			SAE	
				
JIC 37° FJX45 p. 179	JIC 37° FJX90 p. 180	JIC 37° MJ p. 180	SAE FFORX p. 180	SAE FFORX45 p. 181
SAE				
				
SAE FFORX90 p. 181	SAE FL p. 181	SAE FL45 p. 182	SAE FL90 p. 182	SAE FLHCFM p. 182
SAE				
				
SAE FLHCFM45 p. 183	SAE FLHCFM90 p. 183	SAE FLH p. 183	SAE FLH22 p. 184	SAE FLH30 p. 184
SAE			CATERPILLAR	
				
SAE FLH45 p. 184	SAE FLH60 p. 185	SAE FLH90 p. 185	FLC p. 186	FLC22 p. 186

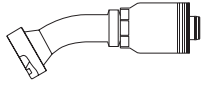
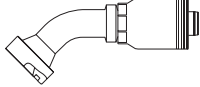
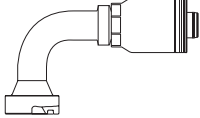
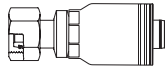
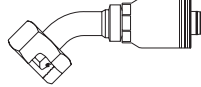

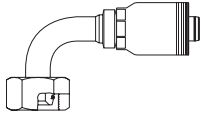
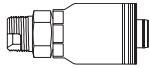
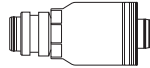
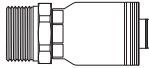
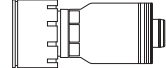
CATERPILLAR			DIN	
				
FLC30 p. 187	FLC45 p. 187	FLC90 p. 188	DIN 24° FDHORX p. 188	DIN 24° FDHORX45 p. 188

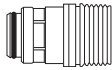
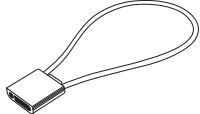
DIN	NPTF	PRESS-LOK SUPER	iLOK™	
				
DIN 24° FDHORX90 p. 189	NPTF MP p. 189	PLSOR p. 190	iLOK™ FILOR p. 190	iLOK™ MILX p. 190

iLOK™	
	
PLSOR to iLOK™ p. 191	iCL p. 191

GlobalSpiral

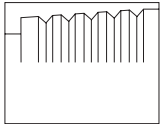
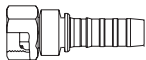
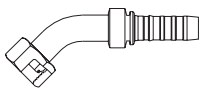
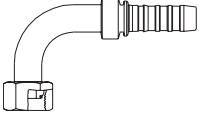



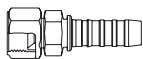
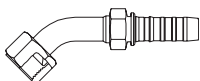
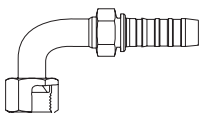
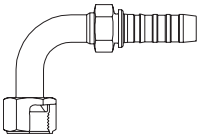
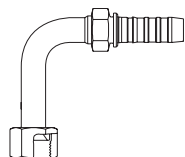





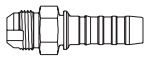
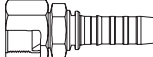
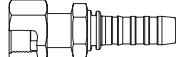
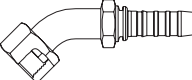
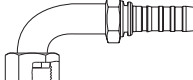
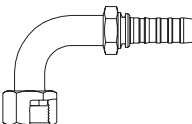
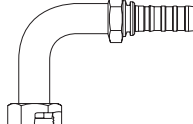



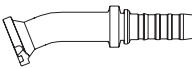
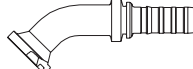

EFG6K (-06:-20), EFG5K (-06:-20), EFG4K, EFG3K (-20:-32), EFG6KL, EFG5KL (-06 -20), EFG4KL, HD-UHP

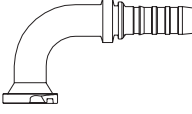
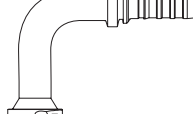

FERRULES	BSP			
				
NO-SKIVE FERRULES p. 192	BSP FBSPORX p. 193	BSP FBSPORX45 p. 193	BSP FBSPORX90 p. 194	BSP MBSPP p. 194

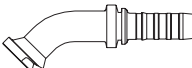
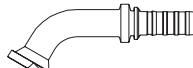
JIC				
				
JIC 37° FJX p. 195	JIC 37° FJX45 p. 196	JIC 37° FJX90S p. 196	JIC 37° FJX90M p. 197	JIC 37° FJX90L p. 197

COUPLING SELECTION TABLE



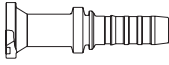

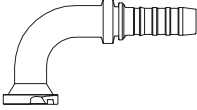
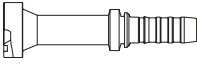
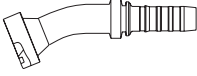
THE WORLD OF COUPLINGS

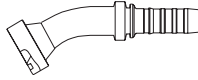
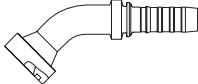
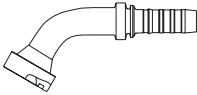
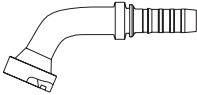
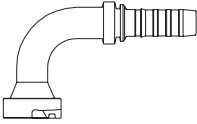
JIC		JIS		SAE		
						
JIC 37° MJ p. 198	JIS FKX p. 198	SAE FFORX p. 199	SAE FFORX45 p. 200	SAE FFORX90S p. 200		
SAE						
						
SAE FFORX90M p. 201	SAE FFORX90L p. 201	SAE MFFOR p. 202	SAE FL p. 202	SAE FL22 p. 203		
SAE						
						
SAE FL30 p. 203	SAE FL45 p. 204	SAE FL60 p. 204	SAE FL67 p. 205	SAE FL90S p. 205		
SAE						
						
SAE FL90M p. 206	SAE FL90L p. 207	SAE FLH p. 207	SAE FLH22 p. 208	SAE FLH30 p. 208		
SAE						
						
SAE FLH45 p. 209	SAE FLH60 p. 209	SAE FLH90S p. 210	SAE FLH90M p. 210	SAE FLH90L p. 211		

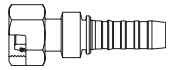
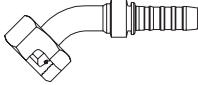
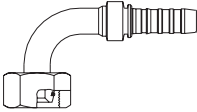
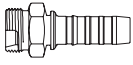
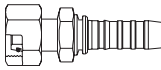
KOMATSU			CATERPILLAR	
				
FLK p. 211	FLK45 p. 211	FLK90 p. 212	FLC p. 212	FLC22 p. 213

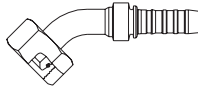
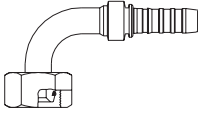
CATERPILLAR				
				
FLC30 p. 213	FLC45 p. 214	FLC60 p. 214	FLC67 p. 215	FLC90 p. 215

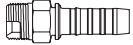

DIN				
				
DIN 24° FDLORX p. 216	DIN 24° FDLORX45 p. 216	DIN 24° FDLORX90 p. 217	DIN 24° MDL p. 217	DIN 24° FDHORX p. 218

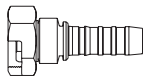
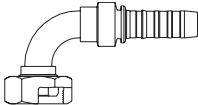
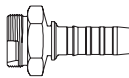
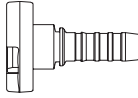
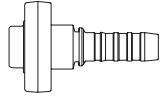
DIN			NPTF	UNF
				
DIN 24° FDHORX45 p. 218	DIN 24° FDHORX90 p. 219	DIN 24° MDH p. 219	NPTF MP p. 220	UNF MB p. 220

FRENCH GAZ				
				
FG FFGX p. 221	FG FFGX90 p. 221	FG MFG p. 221	FG FPFL p. 222	FG MPFL p. 222

COUPLING SELECTION TABLE

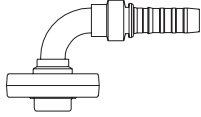
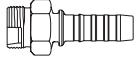

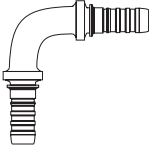
THE WORLD OF COUPLINGS

FRENCH GAZ	KOBELCO	HOSE LENGTH EXTENDER	
			
FG MPFL90 p. 223	KOBELCO MKB p. 223	HLE p. 224	HLE90 p. 224

COUPLINGS FOR WIRE & TEXTILE BRAID HOSE

GlobalSpiral Plus

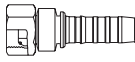
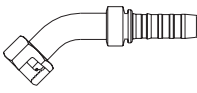
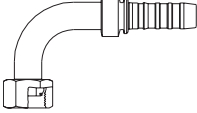
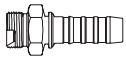
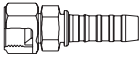
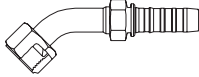
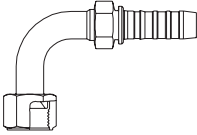
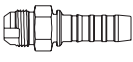
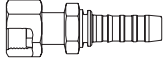
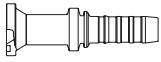
M2T [-24:-32], G2 [-24:-32], G1 [-24:-32], GMV [-24:-32], G2XH [-24:-32], G2H [-24:-32], G2L [-24:-32], G1H [-24:-32], MegaTech [-24:-32], Oil Master Lite SD [-24], GP80 Plus [-24:-32], GP40 [-24]

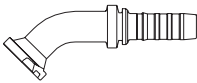
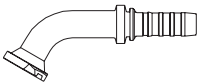
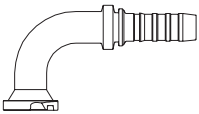
FERRULES	BSP			
				
NO-SKIVE FERRULES p. 228	BSP FBSPORX p. 228	BSP FBSPORX45 p. 228	BSP FBSPORX90 p. 229	BSP MBSPP p. 229
JIC				SAE
				
JIC 37° FJX p. 229	JIC 37° FJX45 p. 230	JIC 37° FJX90 p. 230	JIC 37° MJ p. 230	SAE FFORX p. 231
SAE				
				
SAE FL p. 231	SAE FL30 p. 231	SAE FL45 p. 232	SAE FL60 p. 232	SAE FL90 p. 232

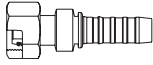
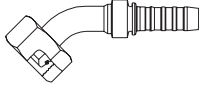
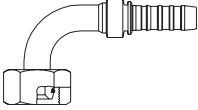
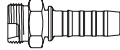
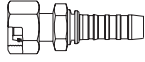
DIN				
				
DIN 24° FDLORX p. 233	DIN 24° FDLORX45 p. 233	DIN 24° FDLORX90 p. 233	DIN 24° MDL p. 234	DIN 24° FDHORX p. 234

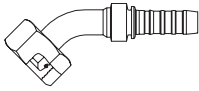
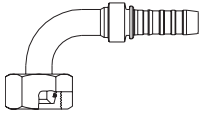
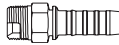
DIN		NPTF
		
DIN 24° FDHORX45 p. 234	DIN 24° FDHORX90 p. 235	NPTF MP p. 235

MegaCrimp®

M6K, M5K, M4K, M3K, CM2T, CM2TDL-XTF, G2 (-04:-16), G1 (-04:-20), TH8, TH7, TH7DL, G3H (-04:-10), GTH, GMV (-04:-20), M4KH, M4KL, M3KH, G2XH (-04:-20), G2H (-20), G2L (-04:-20), G1H (-04:-20), MegaTech (-04:-20), 2JC, 1JC, PowerClean, Oil Master Lite SD (-12:-20), GP80 Plus (-04:-20), GP60, GP40 (-04:-20)

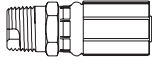
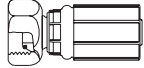
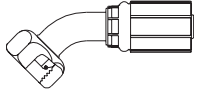
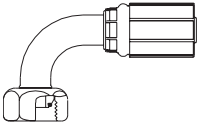
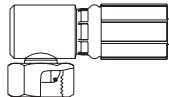
BSP				
				
BSP MBSPT p. 236	BSP FBSPORX p. 237	BSP FBSPORX45 p. 238	BSP FBSPORX90 p. 239	BSP FBSPORX90BL p. 240

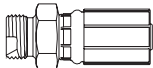
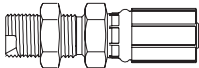
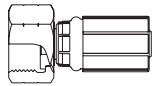
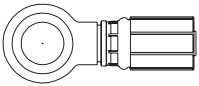
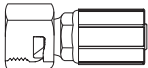
BSP				JIC
				
BSP MBSPP p. 241	BSP MBSPPBKHD p. 241	BSP FBFFX p. 242	BSP BSPBJ p. 242	JIC 37° FJX p. 243

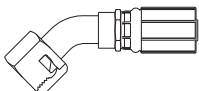
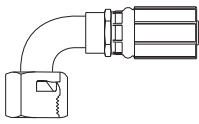
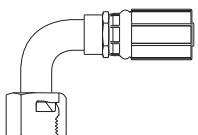
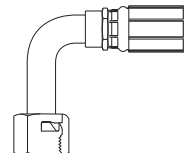
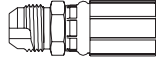
JIC				
				
JIC 37° FJX45 p. 244	JIC 37° FJX90S p. 245	JIC 37° FJX90M p. 246	JIC 37° FJX90L p. 247	JIC 37° MJ p. 248

COUPLING SELECTION TABLE

THE WORLD OF COUPLINGS

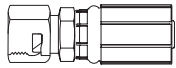
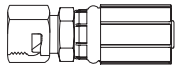
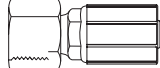
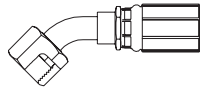
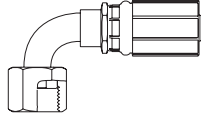
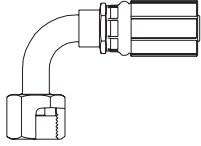
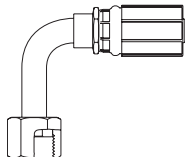
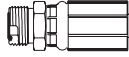
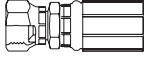
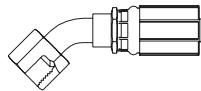
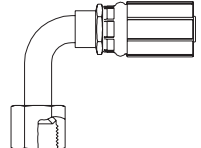
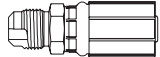
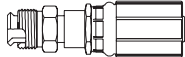
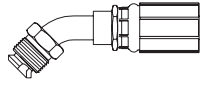
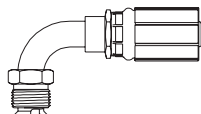
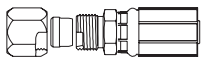
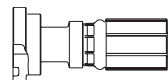
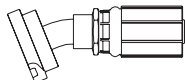
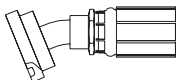
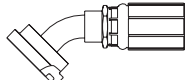
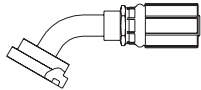
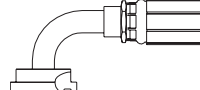
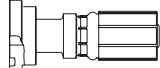
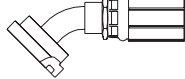
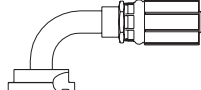
JIS		SAE		
				
JIS FJISX p. 249	JIS FKX p. 249	SAE FFORX p. 250	SAE FFORX45 p. 251	SAE FFORX90S p. 252
SAE				
				
SAE FFORX90M p. 253	SAE FFORX90L p. 254	SAE MFFOR p. 255	SAE 45° FSX p. 255	SAE 45° FSX45 p. 256
SAE				
				
SAE 45° FSX90 p. 256	SAE 45° MS p. 257	SAE 45° MIX p. 257	SAE 45° MIX45 p. 258	SAE 45° MIX90 p. 258
SAE				
				
SAE 24° MFA p. 259	SAE FL p. 259	SAE FL22 p. 260	SAE FL30 p. 260	SAE FL45 p. 261
SAE		KOMATSU		
				
SAE FL60 p. 261	SAE FL90 p. 262	FLK p. 263	FLK45 p. 263	FLK90 p. 263

DIN

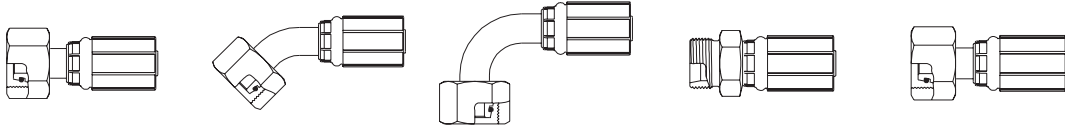

DIN 24° FDLORX p. 264	DIN 24° FDLORX45 p. 265	DIN 24° FDLORX90 p. 266	DIN 24° MDL p. 267	DIN 24° FDHORX p. 268
---------------------------------	-----------------------------------	-----------------------------------	------------------------------	---------------------------------

DIN

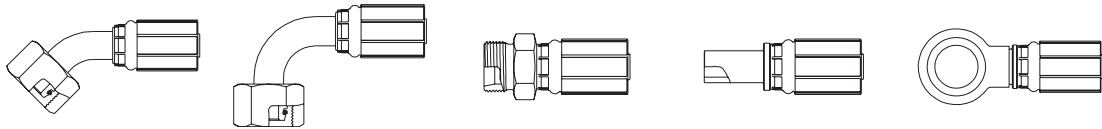

DIN 24° FDHORX45 p. 269	DIN 24° FDHORX90 p. 270	DIN 24° MDH p. 271	METRIC MSP p. 271	METRIC DBJ p. 272
-----------------------------------	-----------------------------------	------------------------------	-----------------------------	-----------------------------

NPTF

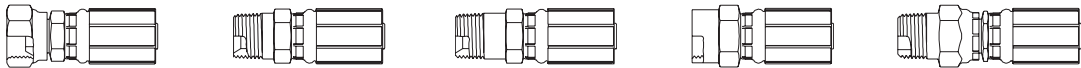

NPTF FPX p. 273	NPTF MP p. 273	NPTF MPLN p. 274	NPTF FP p. 274	NPTF MPX p. 275
---------------------------	--------------------------	----------------------------	--------------------------	---------------------------

NPTF	UNF			
-------------	------------	--	--	--

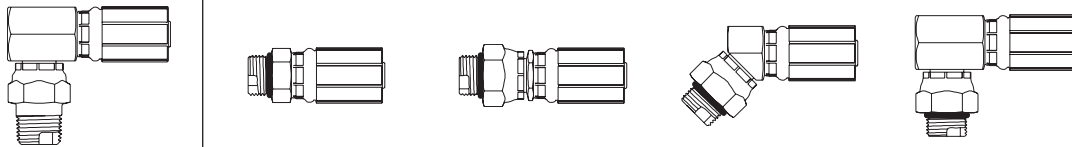

NPTF MPX90 p. 275	UNF MB p. 276	UNF MBX p. 276	UNF MBX45 p. 277	UNF MBX90 p. 277
-----------------------------	-------------------------	--------------------------	----------------------------	----------------------------

FRENCH GAZ	PRESS-LOK
-------------------	------------------

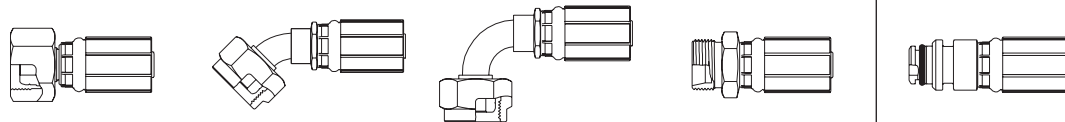

FG FFGX p. 278	FG FFGX45 p. 278	FG FFGX90 p. 279	FG MFG p. 279	PL p. 280
--------------------------	----------------------------	----------------------------	-------------------------	---------------------

COUPLING SELECTION TABLE

THE WORLD OF COUPLINGS

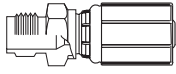
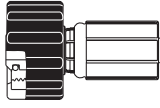
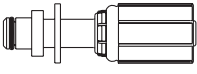
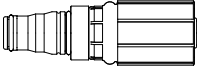
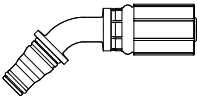

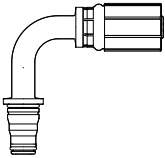
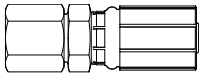
AGRICULTURAL VALVE	POWERWASH		QUICK-LOK HIGH	
				
AV p. 280	POWERWASH FPWX p. 281	POWERWASH PWSP p. 281	MQLH p. 282	MQLH45 p. 282

QUICK-LOK HIGH	
	
MQLH90 p. 283	FQLH p. 283

COUPLINGS FOR WIRE SPIRAL BLASTING HOSE

WTB

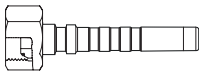
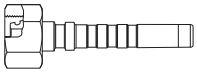
WaterBlast

FERRULES	BSP	DIN	NPTF
			
SKIVE FERRULES p. 286	BSP FBSPORX p. 286	DIN 24° FDHORX p. 287	NPTF MP p. 287

COUPLINGS FOR PUSH-ON TEXTILE HOSE

LOCK-ON

Lock-on Plus

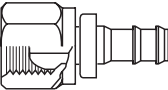
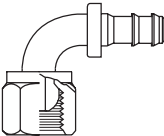
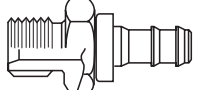
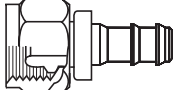
BSP		JIC	DIN
			
BSP FBSPPX p. 290	BSP FBSPPX90 p. 290	BSP MBSPP p. 291	DIN 24° / 60° FDLX p. 292

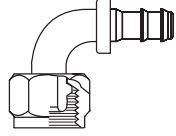
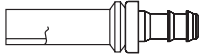
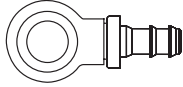
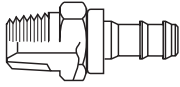



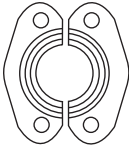
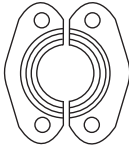
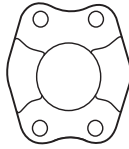

DIN			NPTF
			
DIN 24° / 60° FDLX90 p. 292	METRIC MSP p. 293	METRIC DBJ p. 293	NPTF MP p. 293

ACCESSORIES



FLANGES

SAE		
		
SAE PA-FL flange kit p. 296	SAE PH-FLH flange kit p. 296	SAE PH-FLH Monobloc kit p. 297

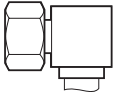
EXPLANATION OF COUPLING NOMENCLATURE

4	G	6	F	BSP	OR	X	45	BL
								
Hose inside diameter in 1/16 inches	GATES GLOBAL REFERENCE MegaCrimp® Coupling	Thread size	Male / female	Type (e.g. BSP)	Soft seal "O" ring	Swivel	Degree of bend (e.g. 45° or 90°)	Compact 90° block
			Termination type					

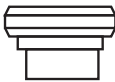
EXPLANATION OF SYMBOLS

Thread	SAE flange size	Banjo bolt size	Coupling
			

THE WORLD OF COUPLINGS
INTEGRATED FLUID POWER SOLUTIONS



COUPLINGS FOR WIRE SPIRAL HYDRAULIC HOSES

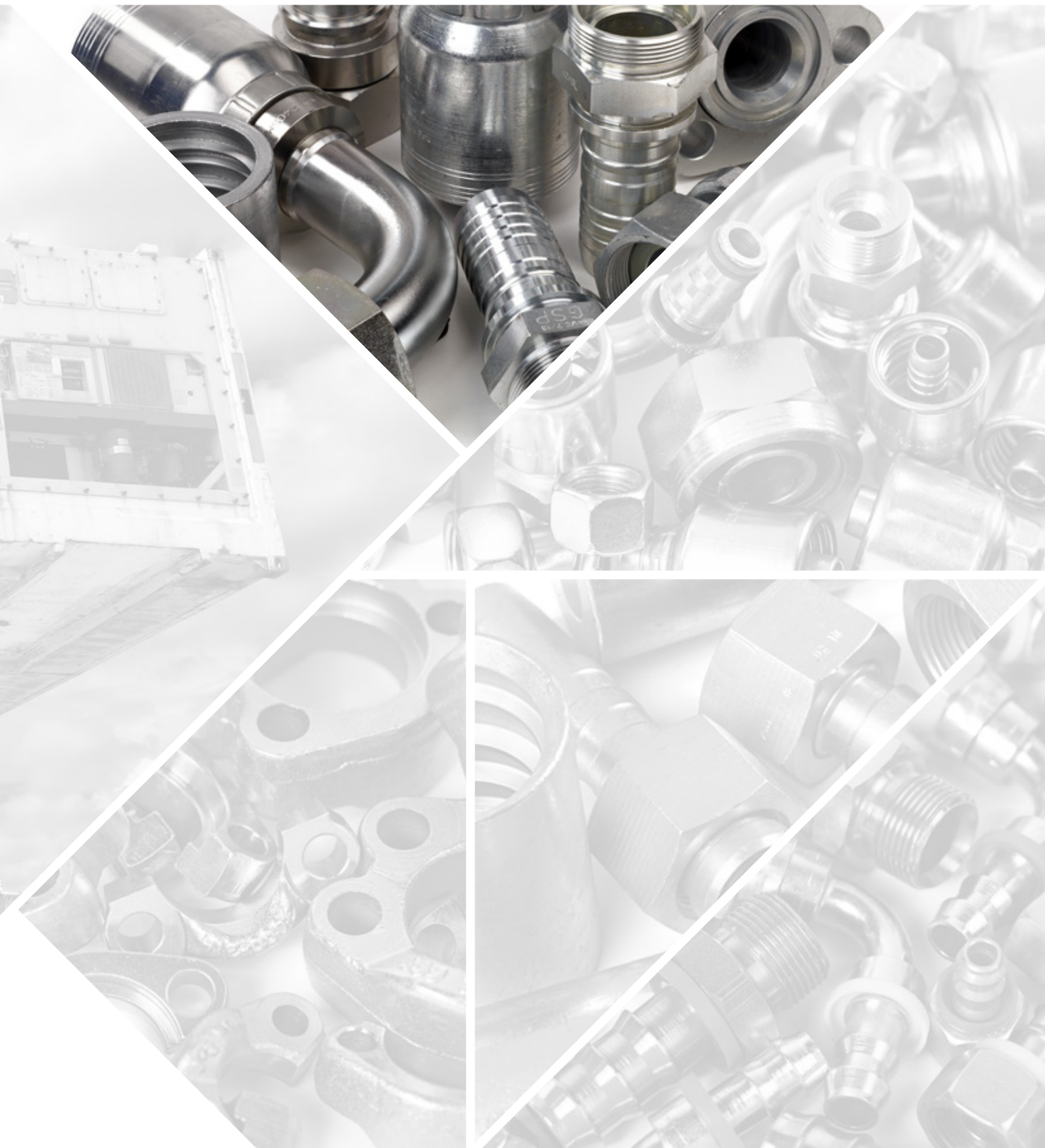

COUPLINGS FOR WIRE SPIRAL HYDRAULIC HOSES GLOBALSPIRAL MAXIMUM

THE WORLD OF COUPLINGS

BSP FBSPORX

Female BSP 'O' ring swivel. 60° cone.

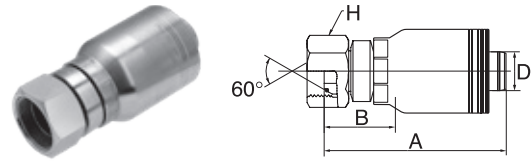

↔			🌀	↔	🌀		
D				A	B	H	REF.
-size	DN	"		mm	mm	mm	GSM
-24	40	1.1/2	G 1.1/2" - 11 BSP	154.0	59.0	55.0	24GSM24FBSPORX
-32	50	2	G 2" - 11 BSP	184.0	70.0	70.0	32GSM32FBSPORX

-24 size is 35.0 MPa (5000 psi); -32 size is 28.0 MPa (4000 psi).

BSP FBSPORX45

Female BSP 'O' ring swivel. 60° cone.
45° swept elbow.

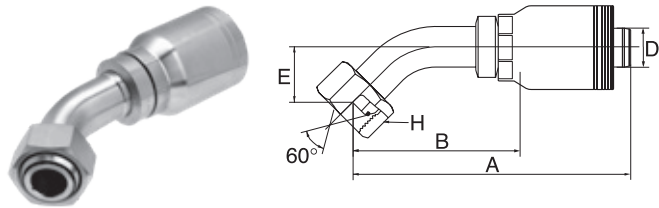

↔			🌀	↔	🌀			
D				A	B	E	H	REF.
-size	DN	"		mm	mm	mm	mm	GSM
-24	40	1.1/2	G 1.1/2" - 11 BSP	242.5	147.5	49.7	55.0	24GSM24FBSPORX45
-32	50	2	G 2" - 11 BSP	307.6	193.6	75.0	70.0	32GSM32FBSPORX45

-24 size is 35.0 MPa (5000 psi); -32 size is 28.0 MPa (4000 psi).

BSP FBSPORX90

Female BSP 'O' ring swivel. 60° cone.
90° swept elbow.

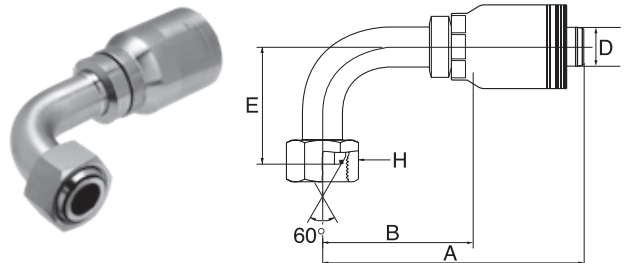

↔			🌀	↔	🌀			
D				A	B	E	H	REF.
-size	DN	"		mm	mm	mm	mm	GSM
-24	40	1.1/2	G 1.1/2" - 11 BSP	222.6	127.6	100.0	55.0	24GSM24FBSPORX90
-32	50	2	G 2" - 11 BSP	276.5	162.5	150.0	70.0	32GSM32FBSPORX90

-24 size is 35.0 MPa (5000 psi); -32 size is 28.0 MPa (4000 psi).

Unless otherwise stated the coupling meets the pressure rating requirements of the respective international standard.

COUPLINGS FOR WIRE SPIRAL HYDRAULIC HOSES GLOBALSPIRAL MAXIMUM

BSP MBSPP

Male BSP parallel. 60° inverted cone.

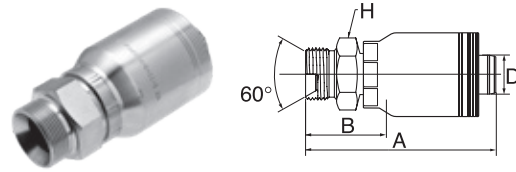

↔			🌀	↔	🌀		REF.
D				A	B	H	GSM
-size	DN	"		mm	mm	mm	
-24	40	1.1/2	G 1.1/2" - 11 BSP	163.0	68.0	55.0	24GSM24MBSPP
-32	50	2	G 2" - 11 BSP	188.0	74.0	70.0	32GSM32MBSPP

-24 size is 35.0 MPa (5000 psi); -32 size is 28.0 MPa (4000 psi).

JIC 37° FJX

Female JIC swivel. 37° inverted cone.

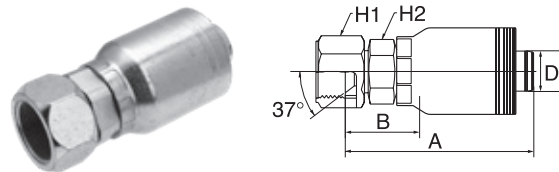

↔			🌀	↔	🌀		REF.	
D				A	B	H1	H2	GSM
-size	DN	"		mm	mm	mm	mm	
-24	40	1.1/2	1.7/8" - 12 UN	152.9	57.9	60.0	55.0	24GSM24FJX
-32	50	2	2.1/2" - 12 UN	180.5	66.5	75.0	70.0	32GSM32FJX

-24 to -32 size are 35.0 MPa (5000 psi).

JIC 37° FJX45

Female JIC swivel. 37° inverted cone.
45° swept elbow.

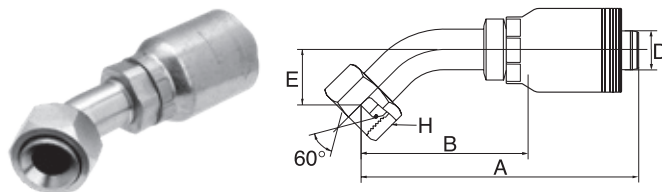

↔			🌀	↔	🌀		REF.		
D				A	B	E	H1	H2	GSM
-size	DN	"		mm	mm	mm	mm	mm	
-24	40	1.1/2	1.7/8" - 12 UN	226.1	130.9	34.0	60.0	55.0	24GSM24FJX45-034

-24 size is 35.0 MPa (5000 psi).

Unless otherwise stated the coupling meets the pressure rating requirements of the respective international standard.

COUPLINGS FOR WIRE SPIRAL HYDRAULIC HOSES GLOBALSPIRAL MAXIMUM

THE WORLD OF COUPLINGS

JIC 37° FJX90

Female JIC swivel. 37° inverted cone.
90° swept elbow.

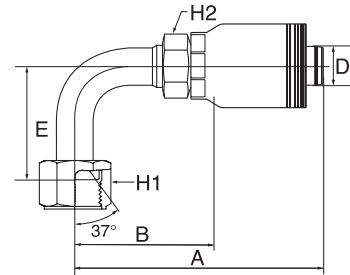

D				A	B	E	H1	H2	REF.
-size	DN	"		mm	mm	mm	mm	mm	GSM
-24	40	1.1/2	1.7/8" - 12 UN	227.5	132.3	86.0	60.0	55.0	24GSM24FJX90M

-24 size is 35.0 MPa (5000 psi). / M: Medium drop per ISO 12151-5.

JIC 37° MJ

Male JIC parallel. 37° cone.

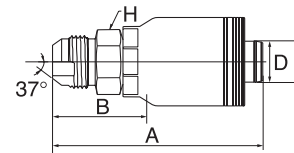

D				A	B	H	REF.
-size	DN	"		mm	mm	mm	GSM
-24	40	1.1/2	1.7/8" - 12 UN	162.3	67.3	50.0	24GSM24MJ
-32	50	2	2.1/2" - 12 UN	196.2	82.2	65.0	32GSM32MJ

-24 to -32 size are 35.0 MPa (5000 psi).

SAE FFORX

Female SAE flat face 'O' ring swivel.

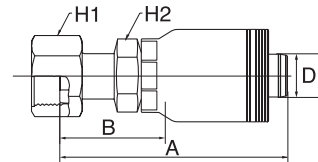

D				A	B	H1	H2	REF.
-size	DN	"		mm	mm	mm	mm	GSM
-24	40	1.1/2	2" - 12 UN	164.4	69.4	60.0	55.0	24GSM24FFORX

-24 size is 28.0 MPa (4000 psi).

Unless otherwise stated the coupling meets the pressure rating requirements of the respective international standard.

COUPLINGS FOR WIRE SPIRAL HYDRAULIC HOSES GLOBALSPIRAL MAXIMUM

SAE FFORX45

Female SAE flat face 'O' ring swivel.
45° swept elbow.

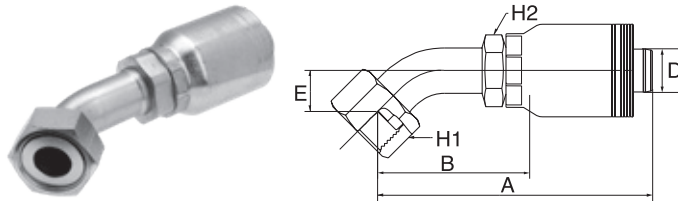

D				A B E H1 H2					REF.
-size	DN	"		mm	mm	mm	mm	mm	GSM
-24	40	1.1/2	2" - 12 UN	236.6	141.4	38.0	60.0	55.0	24GSM24FFORX45-038

-24 size is 28.0 MPa (4000 psi).

SAE FFORX90

Female SAE flat face 'O' ring swivel.
90° swept elbow.

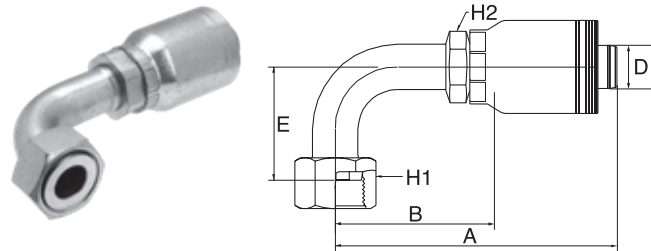

D				A B E H1 H2					REF.
-size	DN	"		mm	mm	mm	mm	mm	GSM
-24	40	1.1/2	2" - 12 UN	227.4	132.3	86.0	60.0	55.0	24GSM24FFORX90M

-24 size is 28.0 MPa (4000 psi). / M: Medium drop per ISO 12151-1.

SAE FL

SAE 'O' ring flange. Code 61.

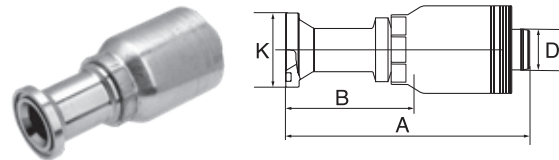

D				A B K			KIT	REF.
-size	DN	"		mm	mm	mm		GSM
-24	40	1.1/2	1.1/2"	180.0	85.0	60.3	24 PA-FL	24GSM24FL
-32	50	2	2"	251.4	137.4	71.4	32 PA-FL	32GSM32FL

Details on flange kits see page 292.

Unless otherwise stated the coupling meets the pressure rating requirements of the respective international standard.

COUPLINGS FOR WIRE SPIRAL HYDRAULIC HOSES GLOBALSPIRAL MAXIMUM

THE WORLD OF COUPLINGS

SAE FL45

SAE 'O' ring flange. Code 61.
45° swept elbow.

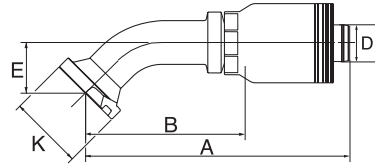

D				A B E K				KIT	REF.
-size	DN	"		mm	mm	mm	mm		GSM
-24	40	1.1/2	1.1/2"	230.0	135.0	44.0	60.3	24 PA-FL	24GSM24FL45M
-32	50	2	2"	288.0	173.6	56.0	71.4	32 PA-FL	32GSM32FL45M

Details on flange kits see page 292. / M: Medium drop per ISO 12151-3.

SAE FL90

SAE 'O' ring flange. Code 61.
90° swept elbow.

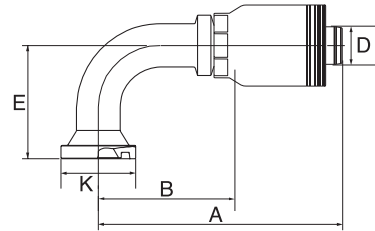

D				A B E K				KIT	REF.
-size	DN	"		mm	mm	mm	mm		GSM
-24	40	1.1/2	1.1/2"	214.9	119.9	81.0	60.3	32 PA-FL	24GSM24FL90S
-32	50	2	2"	265.0	150.5	130.0	71.4	32 PA-FL	32GSM32FL90-130

Details on flange kits see page 292. / S: Short drop per ISO 12151-3.

SAE FLHCFM

SAE 'O' ring flange with pre-installed monobloc.
Code 62.

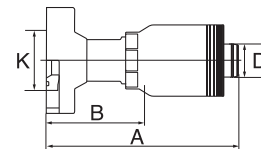

D				A B K			REF.
-size	DN	"		mm	mm	mm	GSM
-24	40	1.1/2	1.1/2"	200.0	105.0	63.5	24GSM24FLHCFM
-32	50	2	2"	251.4	137.4	79.5	32GSM32FLHCFM

Unless otherwise stated the coupling meets the pressure rating requirements of the respective international standard.

COUPLINGS FOR WIRE SPIRAL HYDRAULIC HOSES GLOBALSPIRAL MAXIMUM

SAE FLHCFM45

SAE 'O' ring flange with pre-installed monobloc.
Code 62. 45° swept elbow.

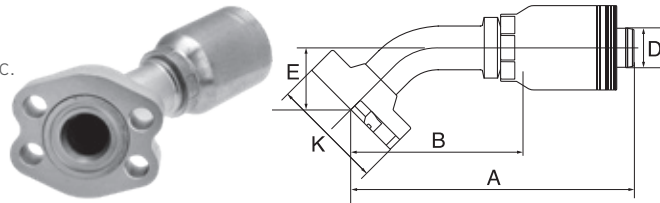

D				A B E K				REF.
-size	DN	"		mm	mm	mm	mm	GSM
-24	40	1.1/2	1.1/2"	232.0	137.0	44.0	63.5	24GSM24FLHCFM45M
-32	50	2	2"	297.0	182.5	63.0	79.5	32GSM32FLHCFM45-063

M: Medium drop per ISO 12151-3.

SAE FLHCFM90

SAE 'O' ring flange with pre-installed monobloc.
Code 62. 90° swept elbow.

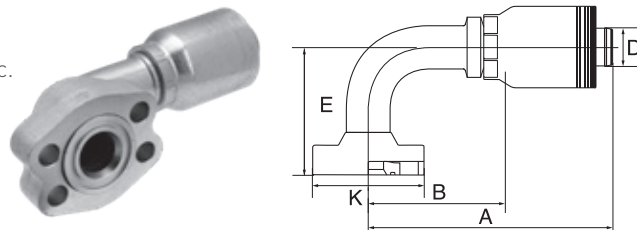

D				A B E K				REF.
-size	DN	"		mm	mm	mm	mm	GSM
-24	40	1.1/2	1.1/2"	214.0	119.0	94.0	63.5	24GSM24FLHCFM90-094
-32	50	2	2"	264.0	150.0	120.0	79.5	32GSM32FLHCFM90S

S: Short drop per ISO 12151-3.

SAE FLH

SAE 'O' ring flange high-pressure. Code 62.

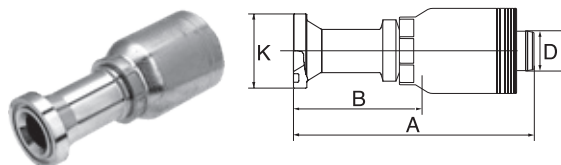

D				A B K			KIT	REF.
-size	DN	"		mm	mm	mm		GSM
-24	40	1.1/2	1.1/2"	200.0	105.0	63.5	24 PH-FLH	24GSM24FLH
-24	40	1.1/2	2"	200.0	105.0	79.5	32 PH-FLH	24GSM32FLH
-32	50	2	1.1/2"	230.0	116.0	63.5	24 PH-FLH	32GSM24FLH
-32	50	2	2"	251.4	137.4	79.5	32 PH-FLH	32GSM32FLH

Details on flange kits see page 292.

Unless otherwise stated the coupling meets the pressure rating requirements of the respective international standard.

COUPLINGS FOR WIRE SPIRAL HYDRAULIC HOSES GLOBALSPIRAL MAXIMUM

THE WORLD OF COUPLINGS

SAE FLH22

SAE 'O' ring flange high-pressure.
Code 62. 22° swept elbow.

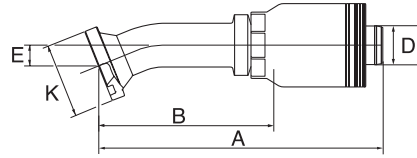

D				A B E K				KIT	REF.
-size	DN	"	1.1/2"	mm	mm	mm	mm		GSM
-24	40	1.1/2	1.1/2"	243.0	148.4	18.0	63.5	24 PH-FLH	24GSM24FLH22M

Details on flange kits see page 292. / M: Medium drop per ISO 12151-3.

SAE FLH30

SAE 'O' ring flange high-pressure.
Code 62. 30° swept elbow.

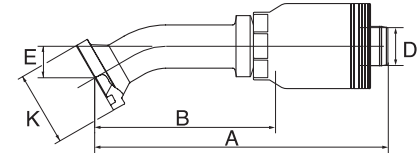

D				A B E K				KIT	REF.
-size	DN	"	1.1/2"	mm	mm	mm	mm		GSM
-24	40	1.1/2	1.1/2"	240.0	144.8	30.0	63.5	24 PH-FLH	24GSM24FLH30M

Details on flange kits see page 292. / M: Medium drop per ISO 12151-3.

SAE FLH45

SAE 'O' ring flange high-pressure.
Code 62. 45° swept elbow.

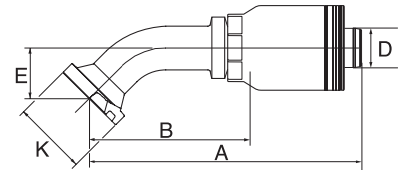

D				A B E K				KIT	REF.
-size	DN	"	1.1/2"	mm	mm	mm	mm		GSM
-24	40	1.1/2	1.1/2"	232.0	137.0	44.0	63.5	24 PH-FLH	24GSM24FLH45M
-24	40	1.1/2	2"	241.0	146.0	56.0	79.5	32 PH-FLH	24GSM32FLH45M
-32	50	2	2"	297.0	182.5	63.0	79.5	32 PH-FLH	32GSM32FLH45-063

Details on flange kits see page 292. / M: Medium drop per ISO 12151-3.

Unless otherwise stated the coupling meets the pressure rating requirements of the respective international standard.

COUPLINGS FOR WIRE SPIRAL HYDRAULIC HOSES GLOBALSPIRAL MAXIMUM

SAE FLH60

SAE 'O' ring flange high-pressure.
Code 62. 60° swept elbow.

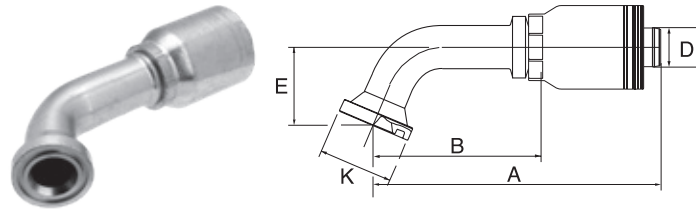

D				A B E K				KIT	REF.
-size	DN	"	1.1/2"	mm	mm	mm	mm		GSM
-24	40	1.1/2	1.1/2"	253.0	158.2	64.0	63.5	24 PH-FLH	24GSM24FLH60M

Details on flange kits see page 292. / M: Medium drop per ISO 12151-3.

SAE FLH90

SAE 'O' ring flange high-pressure.
Code 62. 90° swept elbow.

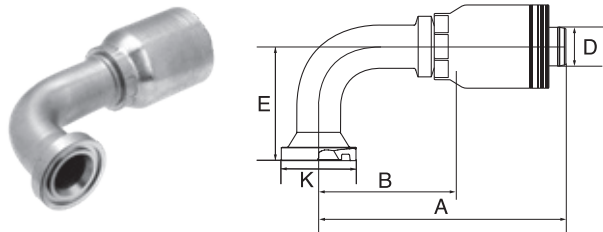

D				A B E K				KIT	REF.
-size	DN	"	1.1/2"	mm	mm	mm	mm		GSM
-24	40	1.1/2	1.1/2"	214.0	119.0	94.0	63.5	24 PH-FLH	24GSM24FLH90-094
-24	40	1.1/2	2"	214.0	118.9	120.0	79.5	32 PH-FLH	24GSM32FLH90S
-32	50	2	2"	264.0	150.0	138.0	79.5	32 PH-FLH	32GSM32FLH90M

Details on flange kits see page 292. / S: Short drop - M: Medium drop per ISO 12151-3.

Unless otherwise stated the coupling meets the pressure rating requirements of the respective international standard.

COUPLINGS FOR WIRE SPIRAL HYDRAULIC HOSES GLOBALSPIRAL MAXIMUM

THE WORLD OF COUPLINGS

FLC

Caterpillar type 'O' ring flange.

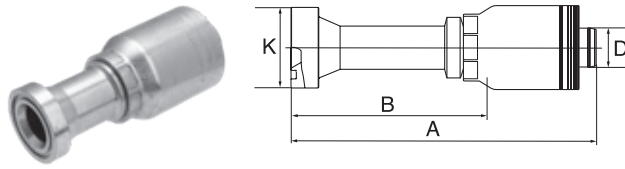

D				A B K			REF.
-size	DN	"		mm	mm	mm	GSM
-24	40	1.1/2	1.1/2"	189.0	94.3	63.5	24GSM24FLC
-24	40	1.1/2	2"	200.0	105.0	79.5	24GSM32FLC
-32	50	2	2"	227.7	113.7	79.5	32GSM32FLC

-24 size is 42.0 MPa (6000 psi). / Note: FLC flanges are designed with a thicker flange head. The 14.2 mm flange dimension is frequently found on Caterpillar equipment. This flange lets the user utilise the Caterpillar flange clamp halves where practical when he replaces the hose assembly. At the user's option, standard Code 62 flanges and flange clamp halves can be used in place of the Caterpillar flanges and flange clamp halves. The standard Code 62 flange head thickness is 12.7 mm.

FLC22

Caterpillar type 'O' ring flange.
22° swept elbow.

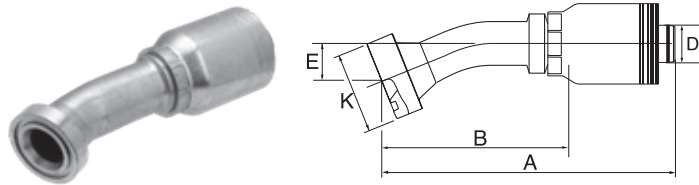

D				A B E K				REF.
-size	DN	"		mm	mm	mm	mm	GSM
-24	40	1.1/2	1.1/2"	236.0	141.5	17.0	63.5	24GSM24FLC22-017

-24 size is 42.0 MPa (6000 psi). / Note: FLC flanges are designed with a thicker flange head. The 14.2 mm flange dimension is frequently found on Caterpillar equipment. This flange lets the user utilise the Caterpillar flange clamp halves where practical when he replaces the hose assembly. At the user's option, standard Code 62 flanges and flange clamp halves can be used in place of the Caterpillar flanges and flange clamp halves. The standard Code 62 flange head thickness is 12.7 mm.

Unless otherwise stated the coupling meets the pressure rating requirements of the respective international standard.

COUPLINGS FOR WIRE SPIRAL HYDRAULIC HOSES GLOBALSPIRAL MAXIMUM

FLC30

Caterpillar type 'O' ring flange.
30° swept elbow.

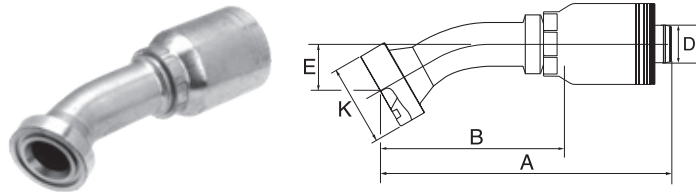

↔			⊕	↔				⊕
D				A	B	E	K	REF.
-size	DN	"		mm	mm	mm	mm	GSM
-24	40	1.1/2	1.1/2"	235.0	139.5	23.0	63.5	24GSM24FLC30-023

-24 size is 42.0 MPa (6000 psi). / Note: FLC flanges are designed with a thicker flange head. The 14.2 mm flange dimension is frequently found on Caterpillar equipment. This flange lets the user utilise the Caterpillar flange clamp halves where practical when he replaces the hose assembly. At the user's option, standard Code 62 flanges and flange clamp halves can be used in place of the Caterpillar flanges and flange clamp halves. The standard Code 62 flange head thickness is 12.7 mm.

FLC45

Caterpillar type 'O' ring flange.
45° swept elbow.

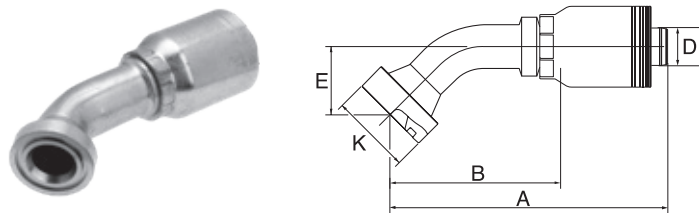

↔			⊕	↔				⊕
D				A	B	E	K	REF.
-size	DN	"		mm	mm	mm	mm	GSM
-24	40	1.1/2	1.1/2"	227.0	132.0	39.0	63.5	24GSM24FLC45-039
-32	50	2	2"	287.5	173.5	64.0	79.5	32GSM32FLC45-064

-24 size is 42.0 MPa (6000 psi). / Note: FLC flanges are designed with a thicker flange head. The 14.2 mm flange dimension is frequently found on Caterpillar equipment. This flange lets the user utilise the Caterpillar flange clamp halves where practical when he replaces the hose assembly. At the user's option, standard Code 62 flanges and flange clamp halves can be used in place of the Caterpillar flanges and flange clamp halves. The standard Code 62 flange head thickness is 12.7 mm.

Unless otherwise stated the coupling meets the pressure rating requirements of the respective international standard.

COUPLINGS FOR WIRE SPIRAL HYDRAULIC HOSES GLOBALSPIRAL MAXIMUM

THE WORLD OF COUPLINGS

FLC90

Caterpillar type 'O' ring flange.
90° swept elbow.

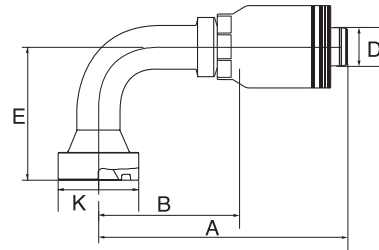

↻			🌀	↔				🌀
D				A	B	E	K	REF.
-size	DN	"		mm	mm	mm	mm	GSM
-24	40	1.1/2	1.1/2"	214.1	119.1	87.0	63.5	24GSM24FLC90-087
-32	50	2	2"	264.5	150.5	130.0	79.5	32GSM32FLC90-130

-24 size is 42.0 MPa (6000 psi). / Note: FLC flanges are designed with a thicker flange head. The 14.2 mm flange dimension is frequently found on Caterpillar equipment. This flange lets the user utilise the Caterpillar flange clamp halves where practical when he replaces the hose assembly. At the user's option, standard Code 62 flanges and flange clamp halves can be used in place of the Caterpillar flanges and flange clamp halves. The standard Code 62 flange head thickness is 12.7 mm.

DIN 24° FDHORX

Female DIN 'O' ring swivel. 24° cone.
Heavy series.

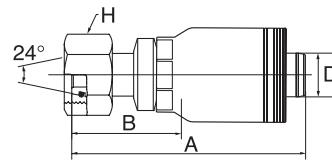

↻			🌀	↔			🌀
D				A	B	H	REF.
-size	DN	"		mm	mm	mm	GSM
-24	40	1.1/2	M52 x 2.0	180.0	85.0	60.0	24GSM38FDHORX

-24 size is 42.0 MPa (6000 psi).

DIN 24° FDHORX45

Female DIN 'O' ring swivel. 24° cone.
Heavy series. 45° swept elbow.

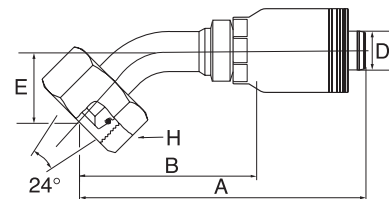

↻			🌀	↔				🌀
D				A	B	E	H	REF.
-size	DN	"		mm	mm	mm	mm	GSM
-24	40	1.1/2	M52 x 2.0	236.9	141.9	44.0	60.0	24GSM38FDHORX45

-24 size is 42.0 MPa (6000 psi).

Unless otherwise stated the coupling meets the pressure rating requirements of the respective international standard.

COUPLINGS FOR WIRE SPIRAL HYDRAULIC HOSES GLOBALSPIRAL MAXIMUM

DIN 24° FDHORX90

Female DIN 'O' ring swivel. 24° cone.
Heavy series. 90° swept elbow.

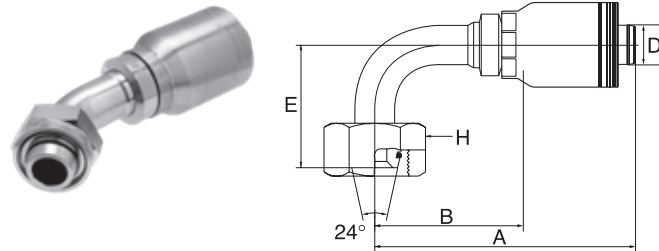

D				A B E			H	REF.
-size	DN	"		mm	mm	mm	mm	GSM
-24	40	1.1/2	M52 x 2.0	222.6	127.6	92.0	60.0	24GSM38FDHORX90

-24 size is 42.0 MPa (6000 psi).

NPTF MP

Male NPTF pipe.

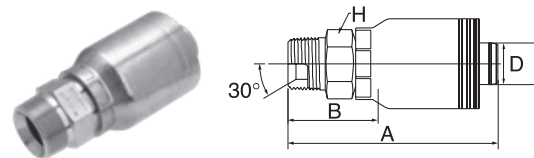

D				A B H			REF.
-size	DN	"		mm	mm	mm	GSM
-24	40	1.1/2	1.1/2" - 11.5 NPTF	165.3	70.3	50.8	24GSM24MP
-32	50	2	2" - 11.5 NPTF	191.6	77.6	69.9	32GSM32MP

-24 size is 24.5 MPa (3500 psi); -32 size is 17.5 MPa (2500 psi). / Warning: Use only in NPTF connections. Do not use in oil field (API) connections. Blow apart of an oil field connection can result in serious injuries.

Unless otherwise stated the coupling meets the pressure rating requirements of the respective international standard.

COUPLINGS FOR WIRE SPIRAL HYDRAULIC HOSES GLOBALSPIRAL MAXIMUM

THE WORLD OF COUPLINGS

PLSOR

Male Press-Lok Super 'O' ring.

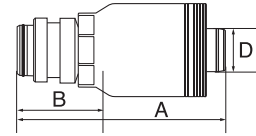

↔			↔		↔
D			A	B	REF.
-size	DN	"	mm	mm	GSM
-24	40	1.1/2	181.1	86.1	24GSM24PLSOR
-32	50	2	204.8	90.8	32GSM32PLSOR

iLOK™ FILOR

Female iLok™ 'O' ring.

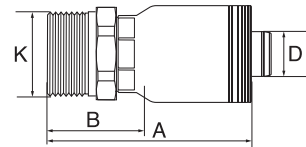

↔			iLOK™	↔			↔
D				A	B	K	REF.
-size	DN	"		mm	mm	mm	GSM
-24	40	1.1/2	24FILOR	183.5	88.5	56.5	24GSM24FILOR
-32	50	2	32FILOR	215.0	101.0	70.5	32GSM32FILOR

Note: iLok™ has a dual pressure rating system depending on the application, -24 to -32 size are 42.0 MPa (6000 psi) for static load and 35.0 MPa (5000 psi) for dynamic load.

iLOK™ MILX

Male iLok™ swivel.

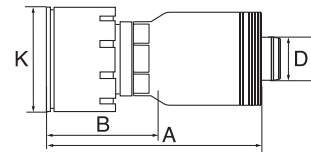

↔			↔	↔			↔
D				A	B	K	REF.
-size	DN	"		mm	mm	mm	GSM
-24	40	1.1/2	24MILX	203.5	108.5	69.6	24GSM24MILX
-32	50	2	32MILX	228.2	114.2	85.0	32GSM32MILX

Note: iLok™ has a dual pressure rating system depending on the application, -24 to -32 size are 42.0 MPa (6000 psi) for static load and 35.0 MPa (5000 psi) for dynamic load.

Unless otherwise stated the coupling meets the pressure rating requirements of the respective international standard.

COUPLINGS FOR WIRE SPIRAL HYDRAULIC HOSES GLOBALSPIRAL MAXIMUM

PLSOR TO iLOK™

Male Press-Lok Super to Female iLok™.

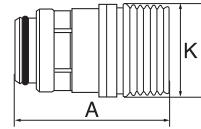



↔			↔		
D			A	K	REF.
-size	DN	"	mm	mm	GSM
-24	40	1.1/2	105.0	56.5	24FILOR-24MSH
-32	50	2	100.0	70.5	32FILOR-32MSH

Note: iLOK™ has a dual pressure rating system depending on the application, -24 to -32 size are 42.0 MPa (6000 psi) for static load and 35.0 MPa (5000 psi) for dynamic load.

ICL

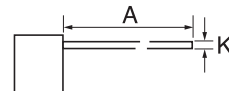
iLok™ Cable



↔			↔		
D			A	K	REF.
-size	DN	"	mm	mm	GSM
-24	40	1.1/2	350.0	3.5	ICL-24-32
-32	50	2	350.0	3.5	ICL-24-32

Note: iLOK™ has a dual pressure rating system depending on the application, -24 to -32 size are 42.0 MPa (6000 psi) for static load and 35.0 MPa (5000 psi) for dynamic load.

Unless otherwise stated the coupling meets the pressure rating requirements of the respective international standard.

COUPLINGS FOR WIRE SPIRAL HYDRAULIC HOSES GLOBALSPIRAL

THE WORLD OF COUPLINGS

NO-SKIVE FERRULES

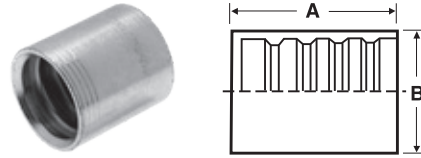

	D		A	B	REF.
-size	DN	"	mm	mm	GS
-6	10	3/8	36.3	31.8	6GS1F-4
-8	12	1/2	36.6	34.4	8GS1F-4
-10	16	5/8	47.8	41.7	10GS1F-4
-12	20	3/4	50.8	45.7	12GS1F-4
-16	25	1	56.4	52.6	16GS1F-4
-20	32	1.1/4	67.8	61.5	20GS1F-4
-20	32	1.1/4	72.9	67.8	20GS1F-6
-24	40	1.1/2	76.5	72.0	24GSP1F-4
-32	50	2	91.0	85.0	32GSP1F-4

Note -24 & -32: Use GSP1F-4 only for 4-spiral wire hose. For 6-spiral wire hose use 1-piece GSM coupling.

Unless otherwise stated the coupling meets the pressure rating requirements of the respective international standard.

COUPLINGS FOR WIRE SPIRAL HYDRAULIC HOSES GLOBALSPIRAL

BSP FBSPORX

Female BSP 'O' ring swivel. 60° cone.

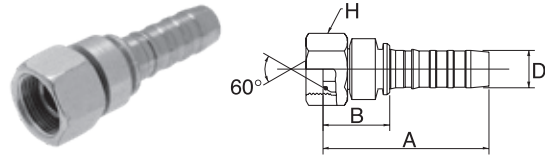

↻			🌀	↔	🔧		
D				A	B	H	REF.
-size	DN	"		mm	mm	mm	GS
-6	10	3/8	G 3/8" - 19 BSP	60.5	24.7	22.0	6GS6FBSPORX
-6	10	3/8	G 1/2" - 14 BSP	60.2	24.4	27.0	6GS8FBSPORX
-8	12	1/2	G 1/2" - 14 BSP	61.0	23.5	27.0	8GS8FBSPORX
-8	12	1/2	G 5/8" - 14 BSP	62.0	24.5	30.0	8GS10FBSPORX
-10	16	5/8	G 5/8" - 14 BSP	80.5	30.2	30.0	10GS10FBSPORX
-10	16	5/8	G 3/4" - 14 BSP	82.3	32.0	32.0	10GS12FBSPORX
-12	20	3/4	G 3/4" - 14 BSP	86.5	35.5	32.0	12GS12FBSPORX
-12	20	3/4	G 1" - 11 BSP	86.6	35.6	41.0	12GS16FBSPORX
-16	25	1	G 1" - 11 BSP	95.0	38.6	41.0	16GS16FBSPORX
-16	25	1	G 1.1/4" - 11 BSP	83.0	26.2	50.0	16GS20FBSPORX
-20	32	1.1/4	G 1.1/4" - 11 BSP	116.5	45.4	50.0	20GS20FBSPORX
-24	40	1.1/2	G 1.1/2" - 11 BSP	125.0	51.3	55.0	24GSP24FBSPORX
-32	50	2	G 2" - 11 BSP	153.0	61.0	70.0	32GSP32FBSPORX

-6 to -20 size are 42.0 MPa (6000 psi).

BSP FBSPORX45

Female BSP 'O' ring swivel. 60° cone.
45° swept elbow.

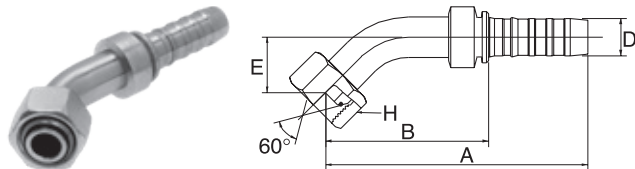

↻			🌀	↔			🔧	
D				A	B	E	H	REF.
-size	DN	"		mm	mm	mm	mm	GS
-6	10	3/8	G 3/8" - 19 BSP	83.1	47.3	15.4	22.0	6GS6FBSPORX45
-8	12	1/2	G 1/2" - 14 BSP	91.5	54.1	17.0	27.0	8GS8FBSPORX45
-10	16	5/8	G 5/8" - 14 BSP	118.0	67.7	21.3	30.0	10GS10FBSPORX45
-10	16	5/8	G 3/4" - 14 BSP	127.9	77.6	31.2	32.0	10GS12FBSPORX45
-12	20	3/4	G 3/4" - 14 BSP	134.4	83.4	28.3	32.0	12GS12FBSPORX45
-16	25	1	G 1" - 11 BSP	155.5	99.1	30.9	41.0	16GS16FBSPORX45
-20	32	1.1/4	G 1.1/4" - 11 BSP	191.1	120.0	37.5	50.0	20GS20FBSPORX45
-24	40	1.1/2	G 1.1/2" - 11 BSP	214.5	140.9	49.7	55.0	24GSP24FBSPORX45
-32	50	2	G 2" - 11 BSP	276.1	184.1	62.3	70.0	32GSP32FBSPORX45

-6 to -20 size are 42.0 MPa (6000 psi).

Unless otherwise stated the coupling meets the pressure rating requirements of the respective international standard.

COUPLINGS FOR WIRE SPIRAL HYDRAULIC HOSES GLOBALSPIRAL

THE WORLD OF COUPLINGS

BSP FBSPORX90

Female BSP 'O' ring swivel. 60° cone.
90° swept elbow.

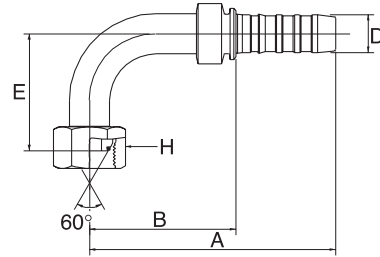

↻			🌀	↔	🌀			REF.
-size	DN	"		A	B	E	H	GS
-6	10	3/8	G 3/8" - 19 BSP	78.0	42.2	32.0	22.0	6GS6FBSPORX90
-8	12	1/2	G 1/2" - 14 BSP	88.0	50.5	37.5	27.0	8GS8FBSPORX90
-10	16	5/8	G 5/8" - 14 BSP	112.5	62.2	46.0	30.0	10GS10FBSPORX90
-10	16	5/8	G 3/4" - 14 BSP	112.5	62.2	60.0	32.0	10GS12FBSPORX90
-12	20	3/4	G 3/4" - 14 BSP	126.0	75.0	60.0	32.0	12GS12FBSPORX90
-16	25	1	G 1" - 11 BSP	151.0	94.6	70.0	41.0	16GS16FBSPORX90
-20	32	1.1/4	G 1.1/4" - 11 BSP	180.5	109.4	80.0	50.0	20GS20FBSPORX90
-24	40	1.1/2	G 1.1/2" - 11 BSP	194.6	121.0	100.0	55.0	24GSP24FBSPORX90
-32	50	2	G 2" - 11 BSP	254.7	162.7	129.1	70.0	32GSP32FBSPORX90

-6 to -20 size are 42.0 MPa (6000 psi).

BSP MBSPP

Male BSP parallel. 60° inverted cone.

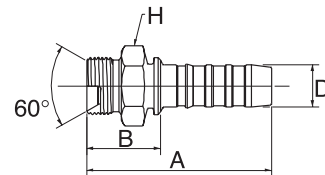

↻			🌀	↔	🌀			REF.
-size	DN	"		A	B	H	GS	
-6	10	3/8	G 3/8" - 19 BSP	63.0	27.2	22.0	6GS6MBSPP	
-6	10	3/8	G 1/2" - 14 BSP	68.0	32.2	27.0	6GS8MBSPP	
-8	12	1/2	G 1/2" - 14 BSP	67.5	30.0	27.0	8GS8MBSPP	
-10	16	5/8	G 5/8" - 14 BSP	84.0	33.7	30.0	10GS10MBSPP	
-10	16	5/8	G 3/4" - 14 BSP	85.0	34.7	32.0	10GS12MBSPP	
-12	20	3/4	G 3/4" - 14 BSP	85.0	34.7	32.0	12GS12MBSPP	
-12	20	3/4	G 1" - 11 BSP	90.0	39.0	41.0	12GS16MBSPP	
-16	25	1	G 1" - 11 BSP	98.0	41.2	41.0	16GS16MBSPP	
-20	32	1.1/4	G 1.1/4" - 11 BSP	118.0	46.9	50.0	20GS20MBSPP	
-24	40	1.1/2	G 1.1/2" - 11 BSP	130.0	56.4	55.0	24GSP24MBSPP	
-32	50	2	G 2" - 11 BSP	148.8	56.8	70.0	32GSP32MBSPP	

-6 to -20 size are 42.0 MPa (6000 psi).





Unless otherwise stated the coupling meets the pressure rating requirements of the respective international standard.

COUPLINGS FOR WIRE SPIRAL HYDRAULIC HOSES GLOBALSPIRAL

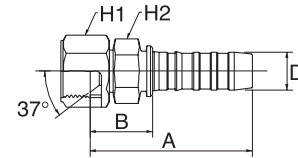
JIC 37° FJX

Female JIC swivel. 37° inverted cone.



								
D				A	B	H1	H2	REF.
-size	DN	"		mm	mm	mm	mm	GS
-6	10	3/8	9/16" - 18 UNF	69.0	33.2	19.1	19.1	6GS6FJX
-6	10	3/8	3/4" - 16 UNF	71.0	35.2	22.2	19.1	6GS8FJX
-8	12	1/2	3/4" - 16 UNF	72.0	34.5	22.2	22.2	8GS8FJX
-8	12	1/2	7/8" - 14 UNF	75.9	38.4	27.0	22.2	8GS10FJX
-8	12	1/2		77.0	39.5	31.8	22.2	8GS12FJX
-10	16	5/8	7/8" - 14 UNF	93.5	43.2	27.0	25.4	10GS10FJX
-10	16	5/8	1.1/16" - 12 UN	95.0	44.7	31.8	25.4	10GS12FJX
-12	20	3/4	7/8" - 14 UNF	98.4	47.4	28.6	27.0	12GS10FJX
-12	20	3/4	1.1/16" - 12 UN	98.0	47.0	31.8	28.6	12GS12FJX
-12	20	3/4	1.3/16" - 12 UN	103.2	52.2	34.9	28.6	12GS14FJX
-12	20	3/4	1.5/16" - 12 UN	102.0	51.0	38.1	28.6	12GS16FJX
-16	25	1	1.1/16" - 12 UN	107.5	50.7	34.9	34.9	16GS12FJX
-16	25	1	1.3/16" - 12 UN	107.9	51.1	38.1	34.9	16GS14FJX
-16	25	1	1.5/16" - 12 UN	109.6	53.3	38.1	38.1	16GS16FJX
-16	25	1	1.5/8" - 12 UN	115.0	58.6	50.8	38.1	16GS20FJX
-20	32	1.1/4	1.5/16" - 12 UN	129.0	57.9	41.3	44.5	20GS16FJX
-20	32	1.1/4	1.5/8" - 12 UN	136.0	64.9	50.8	47.6	20GS20FJX
-20	32	1.1/4	1.7/8" - 12 UN	137.0	65.9	60.3	47.6	20GS24FJX
-24	40	1.1/2	1.7/8" - 12 UN	124.0	50.4	60.0	55.0	24GSP24FJX
-32	50	2	2.1/2" - 12 UN	148.0	56.0	75.0	65.0	32GSP32FJX

-6 to -20 size are 42.0 MPa (6000 psi).

Unless otherwise stated the coupling meets the pressure rating requirements of the respective international standard.

COUPLINGS FOR WIRE SPIRAL HYDRAULIC HOSES GLOBALSPIRAL

THE WORLD OF COUPLINGS

JIC 37° FJX45

Female JIC swivel. 37° inverted cone.
45° swept elbow.

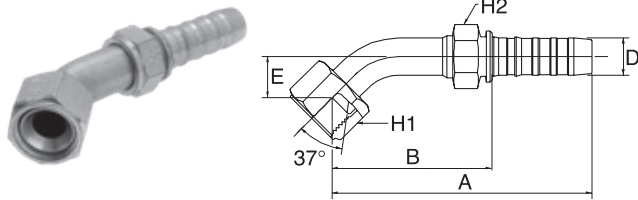

D				A	B	E	H1	H2	REF.
-size	DN	"		mm	mm	mm	mm	mm	GS
-6	10	3/8	9/16" - 18 UNF	82.0	46.2	11.0	19.1	19.1	6GS6FJX45S
-6	10	3/8	3/4" - 16 UNF	93.0	57.2	15.0	22.2	19.1	6GS8FJX45S
-8	12	1/2	3/4" - 16 UNF	94.0	56.5	15.0	22.2	22.2	8GS8FJX45S
-8	12	1/2	7/8" - 14 UNF	91.0	53.5	16.0	27.0	22.2	8GS10FJX45S
-10	16	5/8	7/8" - 14 UNF	113.0	63.0	18.0	27.0	30.0	10GS10FJX45-018
-10	16	5/8	1.1/16" - 12 UN	122.0	71.7	21.0	31.8	25.4	10GS12FJX45S
-12	20	3/4	1.1/16" - 12 UN	130.0	79.0	21.0	31.8	28.6	12GS12FJX45S
-12	20	3/4	1.5/16" - 12 UN	137.0	86.0	24.0	38.1	28.6	12GS16FJX45S
-16	25	1	1.5/16" - 12 UN	152.0	95.6	24.0	38.1	38.1	16GS16FJX45S
-16	25	1	1.5/8" - 12 UN	164.0	107.6	25.0	50.8	38.1	16GS20FJX45S
-20	32	1.1/4	1.5/8" - 12 UN	180.0	108.9	38.0	50.8	47.6	20GS20FJX45-038
-24	40	1.1/2	1.7/8" - 12 UN	233.0	159.5	50.0	60.0	55.0	24GSP24FJX45-050
-32	50	2	2.1/2" - 12 UN	267.0	175.5	65.0	75.0	65.0	32GSP32FJX45-065

-6 to -20 size are 42.0 MPa (6000 psi). / S: Short drop per ISO 12151-5.

JIC 37° FJX90S

Female JIC swivel. 37° inverted cone.
90° swept elbow. Short drop.

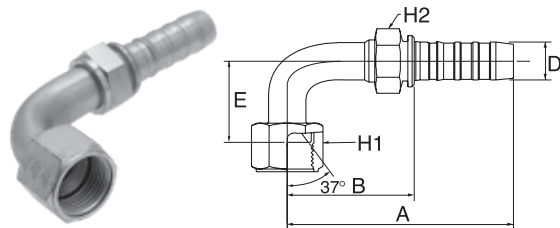

D				A	B	E	H1	H2	REF.
-size	DN	"		mm	mm	mm	mm	mm	GS
-6	10	3/8	9/16" - 18 UNF	79.0	43.2	23.0	19.1	19.1	6GS6FJX90S
-8	12	1/2	3/4" - 16 UNF	86.0	48.6	29.0	22.2	22.2	8GS8FJX90S
-8	12	1/2	7/8" - 14 UNF	92.0	54.5	32.0	27.0	22.2	8GS10FJX90S
-8	12	1/2	1.1/16" - 12 UN	111.0	73.5	48.0	31.8	22.2	8GS12FJX90S
-10	16	5/8	7/8" - 14 UNF	111.0	43.3	36.0	27.0	30.0	10GS10FJX90-036
-12	20	3/4	1.1/16" - 12 UN	119.0	68.0	48.0	31.8	28.6	12GS12FJX90S
-12	20	3/4	1.5/16" - 12 UN	135.0	84.0	56.0	38.1	28.6	12GS16FJX90S
-16	25	1	1.5/16" - 12 UN	144.0	87.6	56.0	38.1	38.1	16GS16FJX90S
-20	32	1.1/4	1.5/8" - 12 UN	174.0	102.9	64.0	50.8	47.6	20GS20FJX90S

-6 to -20 size are 42.0 MPa (6000 psi). / S: Short drop per ISO 12151-5.

Unless otherwise stated the coupling meets the pressure rating requirements of the respective international standard.

COUPLINGS FOR WIRE SPIRAL HYDRAULIC HOSES GLOBALSPIRAL

JIC 37° FJX90M

Female JIC swivel. 37° inverted cone.
90° swept elbow. Medium drop.

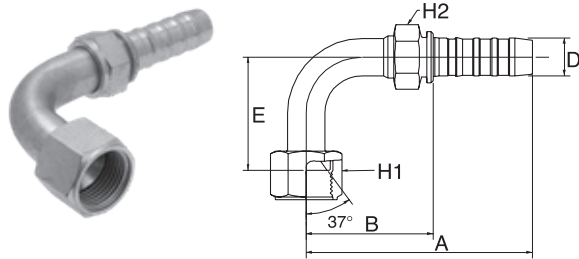

↔			🌀	↔					🔧
D				A	B	E	H1	H2	REF.
-size	DN	"		mm	mm	mm	mm	mm	GS
-6	10	3/8	3/4" - 16 UNF	91.0	55.2	41.0	22.2	19.1	6GS8FJX90M
-8	12	1/2	3/4" - 16 UNF	92.0	54.6	41.0	22.2	22.2	8GS8FJX90M
-8	12	1/2	7/8" - 14 UNF	89.0	51.5	47.0	27.0	22.2	8GS10FJX90M
-10	16	5/8	7/8" - 14 UNF	107.0	57.0	47.0	27.0	30.0	10GS10FJX90M
-10	16	5/8	1.1/16" - 12 UN	121.0	70.7	58.0	31.8	25.4	10GS12FJX90M
-12	20	3/4	1.1/16" - 12 UN	119.0	68.0	58.0	31.8	28.6	12GS12FJX90M
-12	20	3/4	1.3/16" - 12 UN	141.0	90.0	60.0	34.9	28.6	12GS14FJX90-060
-12	20	3/4	1.5/16" - 12 UN	135.0	84.0	71.0	38.1	28.6	12GS16FJX90M
-16	25	1	1.5/16" - 12 UN	144.0	87.6	71.0	38.1	38.1	16GS16FJX90M
-20	32	1.1/4	1.5/8" - 12 UN	174.0	102.9	78.0	50.8	47.6	20GS20FJX90M
-24	40	1.1/2	1.7/8" - 12 UN	212.0	138.4	89.0	60.0	55.0	24GSP24FJX90-089
-32	50	2	2.1/2" - 12 UN	272.0	179.7	140.0	75.0	65.0	32GSP32FJX90M

-6 to -20 size are 42.0 MPa (6000 psi). / M: Medium drop per ISO 12151-5.

JIC 37° FJX90L

Female JIC swivel. 37° inverted cone.
90° swept elbow. Long drop.

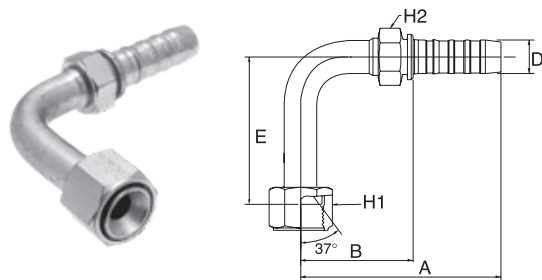

↔			🌀	↔					🔧
D				A	B	E	H1	H2	REF.
-size	DN	"		mm	mm	mm	mm	mm	GS
-6	10	3/8	9/16" - 18 UNF	86.0	50.2	54.0	19.1	19.1	6GS6FJX90L
-8	12	1/2	3/4" - 16 UNF	92.0	54.6	64.0	22.2	22.2	8GS8FJX90L
-8	12	1/2	7/8" - 14 UNF	89.0	51.5	70.0	27.0	22.2	8GS10FJX90L
-12	20	3/4	1.1/16" - 12 UN	113.0	62.0	96.0	31.8	28.6	12GS12FJX90L
-16	25	1	1.5/16" - 12 UN	144.0	87.6	114.0	38.1	38.1	16GS16FJX90L
-16	25	1	1.5/8" - 12 UN	154.0	97.6	129.0	50.8	38.1	16GS20FJX90L
-20	32	1.1/4	1.5/8" - 12 UN	174.0	102.9	129.0	50.8	47.6	20GS20FJX90L

-6 to -20 size are 42.0 MPa (6000 psi). / L: Long drop per ISO 12151-5.

Unless otherwise stated the coupling meets the pressure rating requirements of the respective international standard.

COUPLINGS FOR WIRE SPIRAL HYDRAULIC HOSES GLOBALSPIRAL

THE WORLD OF COUPLINGS

JIC 37° MJ

Male JIC parallel. 37° cone.

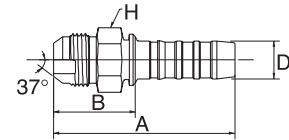

↔			🌀	↔	↔			🌀
D				A	B	H	REF.	
-size	DN	"		mm	mm	mm	GS	
-6	10	3/8	9/16" - 18 UNF	66.0	30.2	17.5	6GS6MJ	
-6	10	3/8	3/4" - 16 UNF	70.0	34.2	20.6	6GS8MJ	
-6	10	3/8	7/8" - 14 UNF	77.0	41.2	23.8	6GS10MJ	
-8	12	1/2	3/4" - 16 UNF	72.0	34.5	20.6	8GS8MJ	
-8	12	1/2	7/8" - 14 UNF	75.0	37.5	22.2	8GS10MJ	
-10	16	5/8	7/8" - 14 UNF	92.0	41.7	23.8	10GS10MJ	
-10	16	5/8	1.1/16" - 12 UN	94.0	43.7	27.0	10GS12MJ	
-12	20	3/4	1.1/16" - 12 UN	93.0	42.0	28.6	12GS12MJ	
-12	20	3/4	1.3/16" - 12 UN	94.0	43.0	31.8	12GS14MJ	
-12	20	3/4	1.5/16" - 12 UN	96.0	45.0	33.3	12GS16MJ	
-16	25	1	1.5/16" - 12 UN	104.0	47.2	34.9	16GS16MJ	
-16	25	1	1.5/8" - 12 UN	108.5	51.7	44.5	16GS20MJ	
-20	32	1.1/4	1.5/8" - 12 UN	125.0	53.9	44.5	20GS20MJ	
-24	40	1.1/2	1.7/8" - 12 UN	130.0	56.4	50.0	24GSP24MJ	
-32	50	2	2.1/2" - 12 UN	161.1	69.1	65.0	32GSP32MJ	

-6 to -20 size are 42.0 MPa (6000 psi).

JIS FKX

Female Japanese swivel. 30° inverted cone.
Metric thread.

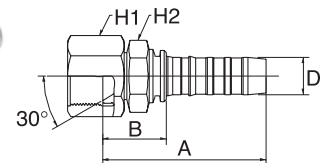

↔			🌀	↔	↔			🌀
D				A	B	H1	H2	REF.
-size	DN	"		mm	mm	mm	mm	GS
-8	12	1/2	M22 x 1.5	61.4	24.0	27.0	27.0	8GS8FKX
-10	16	5/8	M24 x 1.5	80.0	29.7	32.0	30.0	10GS10FKX
-12	20	3/4	M30 x 1.5	83.7	32.7	36.0	32.0	12GS12FKX
-16	25	1	M33 x 1.5	92.6	36.2	41.0	41.0	16GS16FKX

Unless otherwise stated the coupling meets the pressure rating requirements of the respective international standard.

COUPLINGS FOR WIRE SPIRAL HYDRAULIC HOSES GLOBALSPIRAL

SAE FFORX

Female SAE flat face 'O' ring swivel.

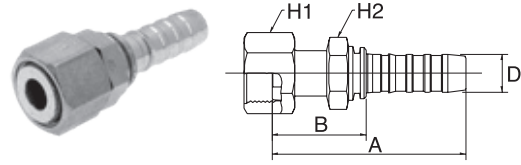

D				A	B	H1	H2	REF.
-size	DN	"		mm	mm	mm	mm	GS
-6	10	3/8	11/16" - 16 UN	69.0	33.2	22.0	22.0	6GS6FFORX
-6	10	3/8	13/16" - 16 UN	72.0	36.2	24.0	22.0	6GS8FFORX
-8	12	1/2	13/16" - 16 UN	71.5	34.0	24.0	27.0	8GS8FFORX
-8	12	1/2	1" - 14 UNS	78.0	40.5	30.0	27.0	8GS10FFORX
-8	12	1/2	1.3/16" - 12 UN	79.0	41.5	36.0	27.0	8GS12FFORX
-10	16	5/8	1" - 14 UNS	93.0	42.7	30.0	30.0	10GS10FFORX
-10	16	5/8	1.3/16" - 12 UN	95.0	44.7	36.0	30.0	10GS12FFORX
-12	20	3/4	1" - 14 UNS	97.0	46.0	30.0	32.0	12GS10FFORX
-12	20	3/4	1.3/16" - 12 UN	100.5	49.5	36.0	32.0	12GS12FFORX
-12	20	3/4	1.7/16" - 12 UN	103.0	52.0	41.0	32.0	12GS16FFORX
-12	20	3/4	1.11/16" - 12 UN	99.3	48.3	50.0	32.0	12GS20FFORX
-16	25	1	1.7/16" - 12 UN	111.0	54.6	41.0	41.0	16GS16FFORX
-16	25	1	1.11/16" - 12 UN	110.7	54.3	50.0	41.0	16GS20FFORX
-20	32	1.1/4	1.11/16" - 12 UN	128.0	56.9	50.0	50.0	20GS20FFORX
-24	40	1.1/2	2" - 12 UN	137.0	63.4	60.0	55.0	24GSP24FFORX

-6 to -20 size are 42.0 MPa (6000 psi).

Unless otherwise stated the coupling meets the pressure rating requirements of the respective international standard.

COUPLINGS FOR WIRE SPIRAL HYDRAULIC HOSES GLOBALSPIRAL

THE WORLD OF COUPLINGS

SAE FFORX45

Female SAE flat face 'O' ring swivel.
45° swept elbow.

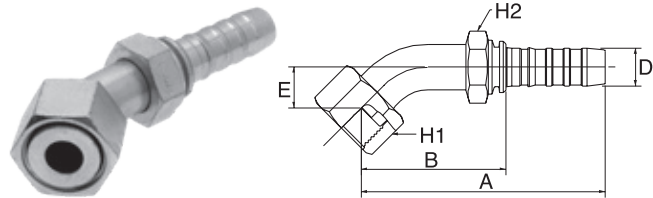

↻			🌀	↔					🔧
D				A	B	E	H1	H2	REF.
-size	DN	"		mm	mm	mm	mm	mm	GS
-6	10	3/8	11/16" - 16 UN	82.0	46.2	11.0	22.0	22.0	6GS6FFORX45S
-6	10	3/8	13/16" - 16 UN	93.0	57.2	15.0	24.0	22.0	6GS8FFORX45S
-8	12	1/2	13/16" - 16 UN	94.0	56.5	15.0	24.0	27.0	8GS8FFORX45S
-8	12	1/2	1" - 14 UNS	99.0	61.5	16.0	30.0	27.0	8GS10FFORX45S
-10	16	5/8	1" - 14 UNS	111.0	60.7	16.0	30.0	30.0	10GS10FFORX45S
-12	20	3/4	1.3/16" - 12 UN	125.0	74.0	21.0	36.0	32.0	12GS12FFORX45S
-12	20	3/4	1.7/16" - 12 UN	137.0	86.0	24.0	41.0	32.0	12GS16FFORX45S
-16	25	1	1.7/16" - 12 UN	144.0	87.6	24.0	41.0	41.0	16GS16FFORX45S
-16	25	1	1.11/16" - 12 UN	164.0	107.6	25.0	50.0	41.0	16GS20FFORX45S
-20	32	1.1/4	1.11/16" - 12 UN	180.0	108.9	32.0	50.0	50.0	20GS20FFORX45-032

-6 to -20 size are 42.0 MPa (6000 psi). / S: Short drop per ISO 12151-1.

SAE FFORX90S

Female SAE flat face 'O' ring swivel.
90° swept elbow. Short drop.

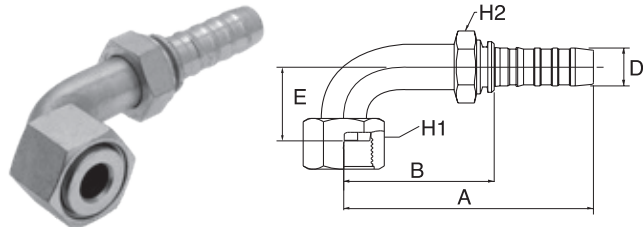

↻			🌀	↔					🔧
D				A	B	E	H1	H2	REF.
-size	DN	"		mm	mm	mm	mm	mm	GS
-6	10	3/8	11/16" - 16 UN	78.0	42.2	23.0	22.0	22.0	6GS6FFORX90S
-8	12	1/2	13/16" - 16 UN	86.0	48.5	29.0	24.0	27.0	8GS8FFORX90S
-8	12	1/2	1.3/16" - 12 UN	107.0	69.5	48.0	36.0	27.0	8GS12FFORX90S
-10	16	5/8	1" - 14 UNS	106.6	56.3	32.0	30.0	30.0	10GS10FFORX90S
-12	20	3/4	1" - 14 UNS	111.0	60.0	32.0	30.0	32.0	12GS10FFORX90S
-12	20	3/4	1.3/16" - 12 UN	128.0	77.0	48.0	36.0	32.0	12GS12FFORX90S
-12	20	3/4	1.7/16" - 12 UN	137.0	86.0	56.0	41.0	32.0	12GS16FFORX90S
-16	25	1	1.7/16" - 12 UN	144.0	87.6	56.0	41.0	41.0	16GS16FFORX90S
-16	25	1	1.11/16" - 12 UN	151.1	94.7	64.0	50.0	41.0	16GS20FFORX90S
-20	32	1.1/4	1.11/16" - 12 UN	172.0	100.9	64.0	50.0	50.0	20GS20FFORX90S
-20	32	1.1/4	2" - 12 UN	172.0	100.9	64.0	60.0	50.0	20GS24FFORX90-064

-6 to -20 size are 42.0 MPa (6000 psi). / S: Short drop per ISO 12151-1.

Unless otherwise stated the coupling meets the pressure rating requirements of the respective international standard.

COUPLINGS FOR WIRE SPIRAL HYDRAULIC HOSES GLOBALSPIRAL

SAE FFORX90M

Female SAE flat face 'O' ring swivel.
90° swept elbow. Medium drop.

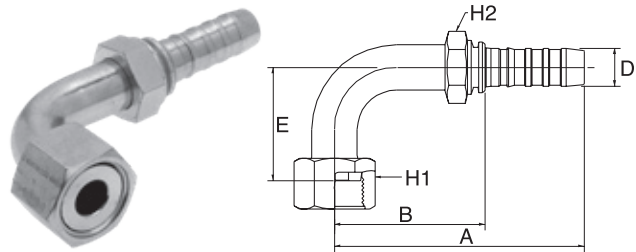

↔			🌀	↔	↔				🌀
D				A	B	E	H1	H2	REF.
-size	DN	"		mm	mm	mm	mm	mm	GS
-6	10	3/8	13/16" - 16 UN	85.0	49.2	41.0	24.0	22.0	6GS8FFORX90M
-8	12	1/2	1.3/16" - 12 UN	101.0	63.5	47.0	30.0	27.0	8GS10FFORX90M
-10	16	5/8	1" - 14 UNS	107.0	56.7	47.0	30.0	30.0	10GS10FFORX90M
-12	20	3/4	1.3/16" - 12 UN	128.0	77.0	58.0	36.0	32.0	12GS12FFORX90M
-16	25	1	1.7/16" - 12 UN	144.0	87.6	71.0	41.0	41.0	16GS16FFORX90M
-16	25	1	1.11/16" - 12 UN	153.6	97.2	78.0	50.0	41.0	16GS20FFORX90M
-20	32	1.1/4	1.11/16" - 12 UN	172.0	100.9	78.0	50.0	50.0	20GS20FFORX90M

-6 to -20 size are 42.0 MPa (6000 psi). / M: Medium drop per ISO 12151-1.

SAE FFORX90L

Female SAE flat face 'O' ring swivel.
90° swept elbow. Long drop.

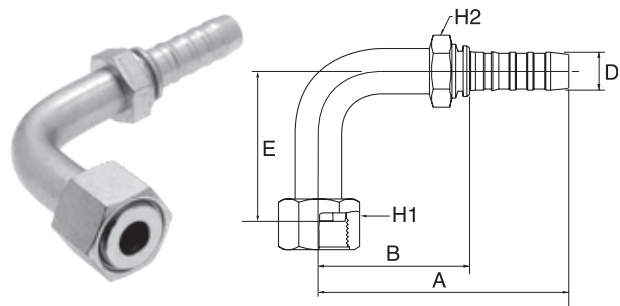

↔			🌀	↔	↔				🌀
D				A	B	E	H1	H2	REF.
-size	DN	"		mm	mm	mm	mm	mm	GS
-6	10	3/8	11/16" - 16 UN	85.0	49.2	54.0	22.0	22.0	6GS6FFORX90L
-8	12	1/2	13/16" - 16 UN	86.0	48.5	83.0	24.0	27.0	8GS8FFORX90-083
-10	16	5/8	1" - 14 UNS	112.9	62.6	70.0	30.0	30.0	10GS10FFORX90L
-12	20	3/4	1.3/16" - 12 UN	128.0	77.0	96.0	36.0	32.0	12GS12FFORX90L
-16	25	1	1.7/16" - 12 UN	144.0	87.6	114.0	41.0	41.0	16GS16FFORX90L
-20	32	1.1/4	1.11/16" - 12 UN	172.0	100.9	129.0	50.0	50.0	20GS20FFORX90L

-6 to -20 size are 42.0 MPa (6000 psi). / L: Long drop per ISO 12151-1.

Unless otherwise stated the coupling meets the pressure rating requirements of the respective international standard.

COUPLINGS FOR WIRE SPIRAL HYDRAULIC HOSES GLOBALSPIRAL

THE WORLD OF COUPLINGS

SAE MFFOR

Male SAE flat face 'O' ring.

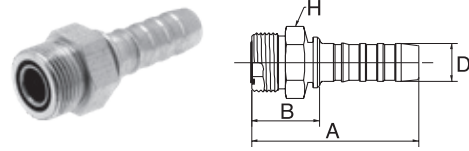

↔			🌀	↔			🌀
D				A	B	H	REF.
-size	DN	"		mm	mm	mm	GS
-6	10	3/8	11/16" - 16 UN	64.0	28.2	19.0	6GS6MFFOR
-8	12	1/2	13/16" - 16 UN	68.0	30.5	22.0	8GS8MFFOR
-12	20	3/4	1.3/16" - 12 UN	89.0	38.0	32.0	12GS12MFFOR
-12	20	3/4	1.7/16" - 12 UN	95.0	44.0	41.0	12GS16MFFOR
-16	25	1	1.7/16" - 12 UN	102.0	45.2	41.0	16GS16MFFOR
-20	32	1.1/4	1.11/16" - 12 UN	120.0	48.9	46.0	20GS20MFFOR

-6 to -20 size are 42.0 MPa (6000 psi).

SAE FL

SAE 'O' ring flange. Code 61.

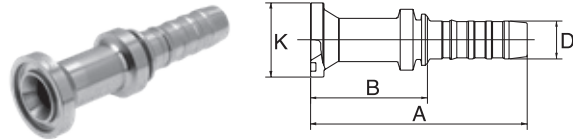

↔			🌀	↔			🌀	
D				A	B	K	KIT	REF.
-size	DN	"		mm	mm	mm		GS
-6	10	3/8	1/2"	90.0	54.2	30.2	8 PA-FL	6GS8FL
-8	12	1/2	1/2"	93.0	55.5	30.2	8 PA-FL	8GS8FL
-8	12	1/2	3/4"	98.0	60.5	38.1	12 PA-FL	8GS12FL
-10	16	5/8	3/4"	109.0	58.7	38.1	12 PA-FL	10GS12FL
-12	20	3/4	1/2"	112.0	61.0	30.2	8 PA-FL	12GS8FL
-12	20	3/4	3/4"	111.0	60.0	38.1	12 PA-FL	12GS12FL
-12	20	3/4	1"	111.0	60.0	44.5	16 PA-FL	12GS16FL
-12	20	3/4	1.1/4"	111.0	60.0	50.8	20 PA-FL	12GS20FL
-16	25	1	1"	125.0	68.6	44.5	16 PA-FL	16GS16FL
-16	25	1	1.1/4"	125.0	68.2	50.8	20 PA-FL	16GS20FL
-16	25	1	1.1/2"	125.0	68.2	60.3	24 PA-FL	16GS24FL
-20	32	1.1/4	1"	136.0	64.9	44.5	16 PA-FL	20GS16FL
-20	32	1.1/4	1.1/4"	146.0	74.9	50.8	20 PA-FL	20GS20FL
-20	32	1.1/4	1.1/2"	160.0	88.9	60.3	24 PA-FL	20GS24FL
-24	40	1.1/2	1.1/2"	152.9	79.3	60.3	24 PA-FL	24GSP24FL
-24	40	1.1/2	2"	152.9	79.3	71.4	32 PA-FL	24GSP32FL
-32	50	2	2"	159.3	67.3	71.4	32 PA-FL	32GSP32FL

Code 61: -16 size is 35.0 MPa (5000 psi). / Details on flange kits see page 292.

Unless otherwise stated the coupling meets the pressure rating requirements of the respective international standard.

COUPLINGS FOR WIRE SPIRAL HYDRAULIC HOSES GLOBALSPIRAL

SAE FL22

SAE 'O' ring flange. Code 61.
22° swept elbow.

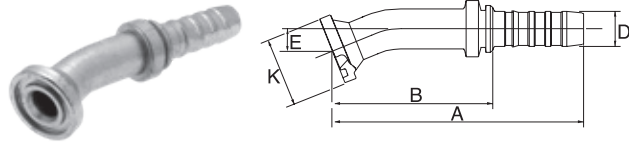

↻			⏏	↔					⏏
D				A	B	E	K	KIT	REF.
-size	DN	"		mm	mm	mm	mm		GS
-8	12	1/2	1/2"	96.0	58.5	9.0	30.2	8 PA-FL	8GS8FL22M
-12	20	3/4	3/4"	131.0	80.0	11.0	38.1	12 PA-FL	12GS12FL22M
-12	20	3/4	1"	133.0	82.0	14.0	44.5	16 PA-FL	12GS16FL22M
-16	25	1	1"	155.0	98.6	14.0	44.5	16 PA-FL	16GS16FL22M
-16	25	1	1.1/4"	168.0	111.4	15.0	50.8	20 PA-FL	16GS20FL22M
-20	32	1.1/4	1.1/4"	178.0	106.9	15.0	50.8	20 PA-FL	20GS20FL22M
-20	32	1.1/4	1.1/2"	186.0	114.9	18.0	60.3	24 PA-FL	20GS24FL22M

Code 61: -16 size is 35.0 MPa (5000 psi). / M: Medium drop per ISO 12151-3. / Details on flange kits see page 292.

SAE FL30

SAE 'O' ring flange. Code 61.
30° swept elbow.

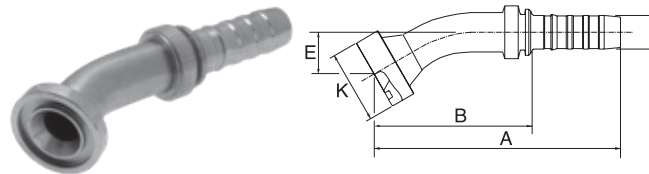

↻			⏏	↔					⏏
D				A	B	E	K	KIT	REF.
-size	DN	"		mm	mm	mm	mm		GS
-12	20	3/4	3/4"	129.0	78.0	16.0	38.1	12 PA-FL	12GS12FL30M
-12	20	3/4	1"	121.0	70.0	19.0	44.5	16 PA-FL	12GS16FL30M
-16	25	1	1"	153.0	96.6	19.0	44.5	16 PA-FL	16GS16FL30M
-16	25	1	1.1/4"	166.0	109.1	22.0	50.8	20 PA-FL	16GS20FL30M
-20	32	1.1/4	1.1/4"	176.0	104.9	22.0	50.8	20 PA-FL	20GS20FL30M
-20	32	1.1/4	1.1/2"	182.0	110.9	30.0	60.3	24 PA-FL	20GS24FL30M
-24	40	1.1/2	1.1/2"	209.0	135.2	25.0	60.3	24 PA-FL	24GSP24FL30S

Code 61: -16 size is 35.0 MPa (5000 psi). / S: Short drop - M: Medium drop per ISO 12151-3. / Details on flange kits see page 292.

Unless otherwise stated the coupling meets the pressure rating requirements of the respective international standard.

COUPLINGS FOR WIRE SPIRAL HYDRAULIC HOSES GLOBALSPIRAL

THE WORLD OF COUPLINGS

SAE FL45

SAE 'O' ring flange. Code 61.
45° swept elbow. Meets ISO 12151-3.

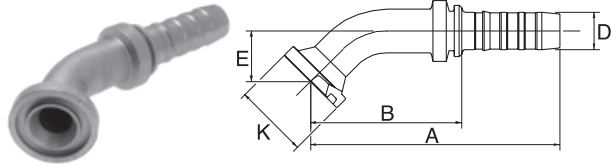

↻			⊕	↔				⊕	⊕
D				A	B	E	K	KIT	REF.
-size	DN	"		mm	mm	mm	mm		GS
-6	10	3/8	1/2"	93.0	57.2	19.0	30.2	8 PA-FL	6GS8FL45M
-8	12	1/2	1/2"	94.0	56.5	19.0	30.2	8 PA-FL	8GS8FL45M
-8	12	1/2	3/4"	101.0	63.5	26.0	38.1	12 PA-FL	8GS12FL45M
-10	16	5/8	3/4"	127.0	76.7	26.0	38.1	12 PA-FL	10GS12FL45M
-12	20	3/4	3/4"	124.0	73.0	26.0	38.1	12 PA-FL	12GS12FL45M
-12	20	3/4	1"	126.0	75.0	28.0	44.5	16 PA-FL	12GS16FL45S
-16	25	1	1"	147.0	90.6	32.0	44.5	16 PA-FL	16GS16FL45M
-16	25	1	1.1/4"	158.0	100.8	38.0	50.8	20 PA-FL	16GS20FL45M
-20	32	1.1/4	1"	163.0	91.9	32.0	44.5	16 PA-FL	20GS16FL45M
-20	32	1.1/4	1.1/4"	170.0	98.9	32.0	50.8	20 PA-FL	20GS20FL45S
-20	32	1.1/4	1.1/2"	176.0	104.9	38.0	60.3	24 PA-FL	20GS24FL45S
-24	40	1.1/2	1.1/2"	202.0	128.6	38.0	60.3	24 PA-FL	24GSP24FL45S
-24	40	1.1/2	2"	200.0	126.3	52.0	71.4	32 PA-FL	24GSP32FL45S
-32	50	2	2"	257.0	165.0	66.0	71.4	32 PA-FL	32GSP32FL45-066

Code 61: -16 size is 35.0 MPa (5000 psi). / S: Short drop - M: Medium drop per ISO 12151-3. / Details on flange kits see page 292.

SAE FL60

SAE 'O' ring flange. Code 61.
60° swept elbow.

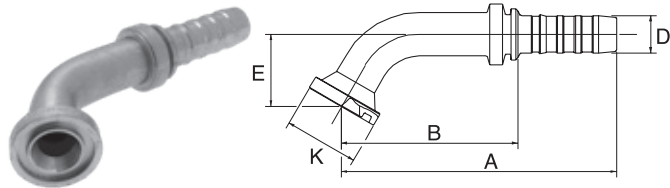

↻			⊕	↔				⊕	⊕
D				A	B	E	K	KIT	REF.
-size	DN	"		mm	mm	mm	mm		GS
-8	12	1/2	1/2"	104.0	66.5	27.0	30.2	8 PA-FL	8GS8FL60M
-12	20	3/4	3/4"	137.0	86.0	37.0	38.1	12 PA-FL	12GS12FL60M
-12	20	3/4	1"	136.0	85.0	44.0	44.5	16 PA-FL	12GS16FL60M
-16	25	1	1"	157.0	100.6	44.0	44.5	16 PA-FL	16GS16FL60M
-16	25	1	1.1/4"	157.0	100.2	55.0	50.8	20 PA-FL	16GS20FL60M
-20	32	1.1/4	1.1/4"	187.0	115.9	55.0	50.8	20 PA-FL	20GS20FL60M
-20	32	1.1/4	1.1/2"	195.0	123.9	64.0	60.3	24 PA-FL	20GS24FL60M
-24	40	1.1/2	1.1/2"	231.0	157.5	53.0	60.3	24 PA-FL	24GSP24FL60S

Code 61: -16 size is 35.0 MPa (5000 psi). / S: Short drop - M: Medium drop per ISO 12151-3. / Details on flange kits see page 292.

Unless otherwise stated the coupling meets the pressure rating requirements of the respective international standard.

COUPLINGS FOR WIRE SPIRAL HYDRAULIC HOSES GLOBALSPIRAL

SAE FL67

SAE 'O' ring flange. Code 61.
67° swept elbow.

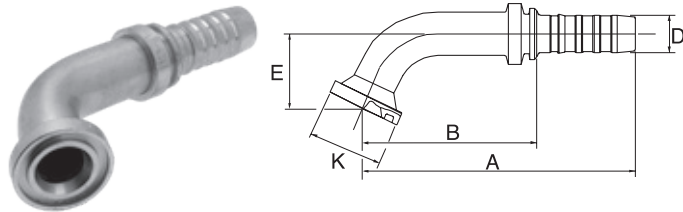

↻			⏏	↔					⏏
D				A	B	E	K	KIT	REF.
-size	DN	"		mm	mm	mm	mm		GS
-12	20	3/4	1"	129.0	78.0	51.0	44.5	16 PA-FL	12GS16FL67M
-16	25	1	1"	151.0	94.6	51.0	44.5	16 PA-FL	16GS16FL67M
-16	25	1	1.1/4"	148.0	91.2	64.0	50.8	20 PA-FL	16GS20FL67M
-20	32	1.1/4	1.1/4"	179.0	107.7	64.0	50.8	20 PA-FL	20GS20FL67M

Code 61: -16 size is 35.0 MPa (5000 psi). / M: Medium drop per ISO 12151-3. / Details on flange kits see page 292.

SAE FL90S

SAE 'O' ring flange. Code 61.
90° swept elbow. Short drop.

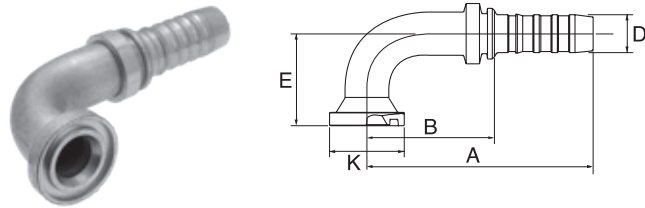

↻			⏏	↔					⏏
D				A	B	E	K	KIT	REF.
-size	DN	"		mm	mm	mm	mm		GS
-12	20	3/4	1"	128.0	77.0	61.0	44.5	16 PA-FL	12GS16FL90S
-16	25	1	1"	135.0	78.6	61.0	44.5	16 PA-FL	16GS16FL90S
-16	25	1	1.1/4"	134.0	76.8	68.0	50.8	20 PA-FL	16GS20FL90S
-16	25	1	1.1/2"	134.0	77.2	81.0	60.3	24 PA-FL	16GS24FL90S
-20	32	1.1/4	1.1/4"	165.0	93.9	68.0	50.8	20 PA-FL	20GS20FL90S
-20	32	1.1/4	1.1/2"	166.0	94.9	81.0	60.3	24 PA-FL	20GS24FL90S
-24	40	1.1/2	1.1/2"	184.0	109.9	81.0	60.3	24 PA-FL	24GSP24FL90S

Code 61: -16 size is 35.0 MPa (5000 psi). / S: Short drop per ISO 12151-3. / Details on flange kits see page 292.

Unless otherwise stated the coupling meets the pressure rating requirements of the respective international standard.

COUPLINGS FOR WIRE SPIRAL HYDRAULIC HOSES GLOBALSPIRAL

THE WORLD OF COUPLINGS

SAE FL90M

SAE 'O' ring flange. Code 61.
90° swept elbow. Medium drop.

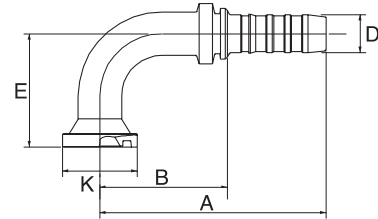

D				A	B	E	K	KIT	REF.
-size	DN	"		mm	mm	mm	mm		GS
-6	10	3/8	1/2"	87.0	51.2	40.0	30.2	8 PA-FL	6GS8FL90M
-8	12	1/2	1/2"	88.0	50.5	40.0	30.2	8 PA-FL	8GS8FL90M
-8	12	1/2	3/4"	88.0	50.4	58.0	38.1	12 PA-FL	8GS12FL90M
-10	16	5/8	3/4"	110.0	59.7	58.0	38.1	12 PA-FL	10GS12FL90M
-12	20	3/4	1/2"	122.0	71.0	50.0	30.2	8 PA-FL	12GS8FL90-050
-12	20	3/4	3/4"	112.0	61.0	58.0	38.1	12 PA-FL	12GS12FL90M
-12	20	3/4	1"	128.0	77.0	70.0	44.5	16 PA-FL	12GS16FL90M
-16	25	1	1"	135.0	78.6	70.0	44.5	16 PA-FL	16GS16FL90M
-16	25	1	1.1/4"	134.0	76.8	90.0	50.8	20 PA-FL	16GS20FL90M
-20	32	1.1/4	1"	160.0	88.9	70.0	44.5	16 PA-FL	20GS16FL90M
-20	32	1.1/4	1.1/4"	166.0	94.9	90.0	50.8	20 PA-FL	20GS20FL90M
-20	32	1.1/4	1.1/2"	165.0	93.9	118.0	60.3	24 PA-FL	20GS24FL90-118
-24	40	1.1/2	2"	175.0	101.9	80.0	71.4	32 PA-FL	24GSP32FL90-080
-32	50	2	2"	222.0	130.1	114.0	71.4	32 PA-FL	32GSP32FL90-114

Code 61: -16 size is 35.0 MPa (5000 psi). / M: Medium drop per ISO 12151-3. / Details on flange kits see page 292.

Unless otherwise stated the coupling meets the pressure rating requirements of the respective international standard.

COUPLINGS FOR WIRE SPIRAL HYDRAULIC HOSES GLOBALSPIRAL

SAE FL90L

SAE 'O' ring flange. Code 61.
90° swept elbow. Long drop.

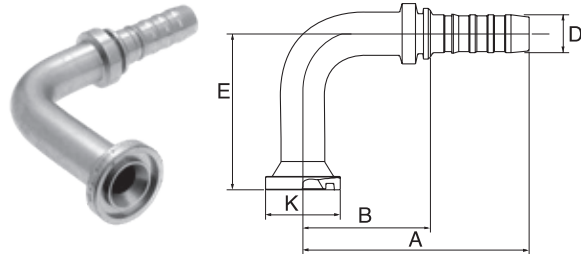

↻			⊕	↔					⊕
D				A	B	E	K	KIT	REF.
-size	DN	"		mm	mm	mm	mm		GS
-10	16	5/8	3/4"	110.0	59.7	100.0	38.1	12 PA-FL	10GS12FL90-100
-12	20	3/4	3/4"	122.0	71.0	100.0	38.1	12 PA-FL	12GS12FL90-100
-12	20	3/4	3/4"	122.0	71.0	125.0	38.1	12 PA-FL	12GS12FL90-125
-12	20	3/4	3/4"	116.0	65.0	150.0	38.1	12 PA-FL	12GS12FL90-150
-12	20	3/4	1"	116.0	65.0	100.0	44.5	16 PA-FL	12GS16FL90-100
-16	25	1	1"	135.0	78.6	100.0	44.5	16 PA-FL	16GS16FL90-100
-16	25	1	1"	134.0	77.6	120.0	44.5	16 PA-FL	16GS16FL90-120
-20	32	1.1/4	1.1/4"	166.0	94.9	168.0	50.8	20 PA-FL	20GS20FL90-168

Code 61: -16 size is 35.0 MPa (5000 psi); -20: 28.0 MPa (4000 psi). / Details on flange kits see page 292.

SAE FLH

SAE 'O' ring flange high-pressure.
Code 62.

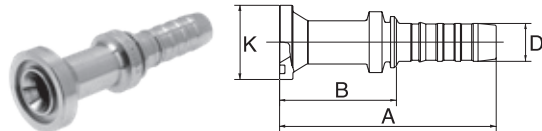

↻			⊕	↔				⊕	
D				A	B	K	KIT	REF.	
-size	DN	"		mm	mm	mm		GS	
-8	12	1/2	1/2"	93.0	55.5	31.8	8 PH-FLH	8FLHCFM	8GS8FLH
-8	12	1/2	3/4"	93.0	55.5	41.3	12 PH-FLH	12FLHCFM	8GS12FLH
-10	16	5/8	1/2"	109.0	58.7	31.8	8 PH-FLH		10GS8FLH
-10	16	5/8	3/4"	109.0	58.7	41.3	12 PH-FLH	12FLHCFM	10GS12FLH
-12	20	3/4	3/4"	114.0	63.0	41.3	12 PH-FLH	12FLHCFM	12GS12FLH
-12	20	3/4	1"	114.0	63.0	47.6	16 PH-FLH	16FLHCFM	12GS16FLH
-16	25	1	3/4"	129.0	72.6	41.3	12 PH-FLH		16GS12FLH
-16	25	1	1"	125.0	68.6	47.6	16 PH-FLH	16FLHCFM	16GS16FLH
-16	25	1	1.1/4"	125.0	68.2	54.0	20 PH-FLH	20FLHCFM	16GS20FLH
-20	32	1.1/4	1"	163.0	91.9	47.6	16 PH-FLH		20GS16FLH
-20	32	1.1/4	1.1/4"	146.0	74.9	54.0	20 PH-FLH	20FLHCFM	20GS20FLH
-20	32	1.1/4	1.1/2"	160.0	88.9	63.5	24 PH-FLH	24FLHCFM	20GS24FLH

Details on flange kits see page 292.

Unless otherwise stated the coupling meets the pressure rating requirements of the respective international standard.

COUPLINGS FOR WIRE SPIRAL HYDRAULIC HOSES GLOBALSPIRAL

THE WORLD OF COUPLINGS

SAE FLH22

SAE 'O' ring flange high-pressure.
Code 62. 22° swept elbow.

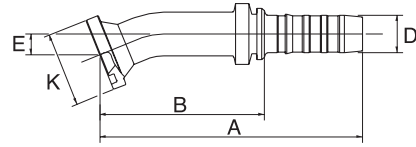

↔			⊕	↔						⊕
D				A	B	E	K	KIT	KIT	REF.
-size	DN	"		mm	mm	mm	mm			GS
-16	25	1	1"	155.0	98.6	14.0	47.6	16 PH-FLH	16FLHCFM	16GS16FLH22M
-20	32	1.1/4	1.1/4"	186.0	114.9	15.0	54.0	20 PH-FLH		20GS20FLH22M

M: Medium drop per ISO 12151-3. / Details on flange kits see page 292.

SAE FLH30

SAE 'O' ring flange high-pressure.
Code 62. 30° swept elbow.

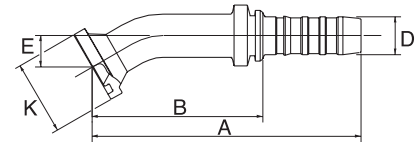

↔			⊕	↔						⊕
D				A	B	E	K	KIT	KIT	REF.
-size	DN	"		mm	mm	mm	mm			GS
-16	25	1	1"	153.0	96.6	19.0	47.6	16 PH-FLH	16FLHCFM	16GS16FLH30M
-16	25	1	1.1/4"	166.0	109.1	22.0	54.0	20 PH-FLH	20FLHCFM	16GS20FLH30M
-20	32	1.1/4	1.1/4"	184.0	112.9	22.0	54.0	20 PH-FLH		20GS20FLH30M
-20	32	1.1/4	1.1/2"	184.0	112.9	30.0	63.5	24 PH-FLH	24FLHCFM	20GS24FLH30M

M: Medium drop per ISO 12151-3. / Details on flange kits see page 292.

Unless otherwise stated the coupling meets the pressure rating requirements of the respective international standard.

COUPLINGS FOR WIRE SPIRAL HYDRAULIC HOSES GLOBALSPIRAL

SAE FLH45

SAE 'O' ring flange high-pressure.
Code 62. 45° swept elbow.

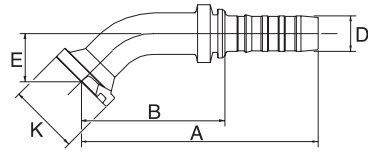

D				A B E K				KIT	KIT	REF.
-size	DN	"		mm	mm	mm	mm			GS
-8	12	1/2	1/2"	94.0	56.5	19.0	31.8	8 PH-FLH	8FLHCFM	8GS8FLH45M
-8	12	1/2	3/4"	101.0	63.5	26.0	41.3	12 PH-FLH	12FLHCFM	8GS12FLH45M
-10	16	5/8	1/2"	115.0	64.7	19.0	31.8	8 PH-FLH		10GS8FLH45M
-10	16	5/8	3/4"	127.0	76.7	26.0	41.3	12 PH-FLH	12FLHCFM	10GS12FLH45M
-12	20	3/4	3/4"	124.0	73.0	26.0	41.3	12 PH-FLH	12FLHCFM	12GS12FLH45M
-12	20	3/4	1"	130.0	79.0	32.0	47.6	16 PH-FLH	16FLHCFM	12GS16FLH45M
-16	25	1	3/4"	141.0	84.2	26.0	41.3	12 PH-FLH		16GS12FLH45M
-16	25	1	1"	147.0	90.6	32.0	47.6	16 PH-FLH	16FLHCFM	16GS16FLH45M
-16	25	1	1.1/4"	158.0	101.2	38.0	54.0	20 PH-FLH	20FLHCFM	16GS20FLH45M
-20	32	1.1/4	1"	191.1	120.0	33.7	47.6	16 PH-FLH		20GS16FLH45-034
-20	32	1.1/4	1.1/4"	176.0	104.9	38.1	54.0	20 PH-FLH	20FLHCFM	20GS20FLH45M
-20	32	1.1/4	1.1/2"	176.0	104.9	44.0	63.5	24 PH-FLH	24FLHCFM	20GS24FLH45M

M: Medium drop per ISO 12151-3. / Details on flange kits see page 292.

SAE FLH60

SAE 'O' ring flange high-pressure.
Code 62. 60° swept elbow.

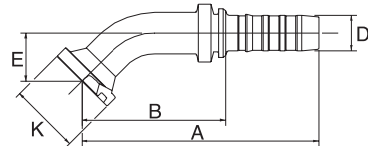

D				A B E K				KIT	KIT	REF.
-size	DN	"		mm	mm	mm	mm			GS
-12	20	3/4	3/4"	137.0	86.0	37.0	41.3	12 PH-FLH	12FLHCFM	12GS12FLH60M
-12	20	3/4	1"	136.0	85.0	44.0	47.6	16 PH-FLH	16FLHCFM	12GS16FLH60M
-16	25	1	1"	157.0	100.6	44.0	47.6	16 PH-FLH	16FLHCFM	16GS16FLH60M
-20	32	1.1/4	1.1/4"	186.0	114.9	55.0	54.0	20 PH-FLH		20GS20FLH60M

M: Medium drop per ISO 12151-3. / Details on flange kits see page 292.

Unless otherwise stated the coupling meets the pressure rating requirements of the respective international standard.

COUPLINGS FOR WIRE SPIRAL HYDRAULIC HOSES GLOBALSPIRAL

THE WORLD OF COUPLINGS

SAE FLH90S

SAE 'O' ring flange high-pressure.
Code 62. 90° swept elbow. Short drop.

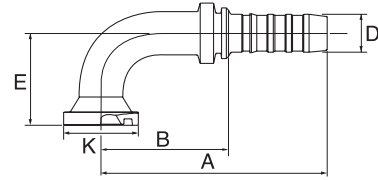

D				A B E K				KIT	KIT	REF.
-size	DN	"		mm	mm	mm	mm			GS
-16	25	1	1"	135.0	78.6	61.0	47.6	16 PH-FLH	16FLHCFM	16GS16FLH90S
-16	25	1	1.1/4"	134.0	76.8	68.0	54.0	20 PH-FLH	20FLHCFM	16GS20FLH90S
-16	25	1	1.1/2"	134.0	77.2	81.0	63.5	24 PH-FLH	24FLHCFM	16GS24FLH90S
-20	32	1.1/4	1"	160.0	88.9	61.0	47.6	16 PH-FLH		20GS16FLH90S
-20	32	1.1/4	1.1/2"	165.0	93.9	81.0	63.5	24 PH-FLH	24FLHCFM	20GS24FLH90S

S: Short drop per ISO 12151-3. / Details on flange kits see page 292.

SAE FLH90M

SAE 'O' ring flange high-pressure. Code 62.
90° swept elbow. Medium drop.

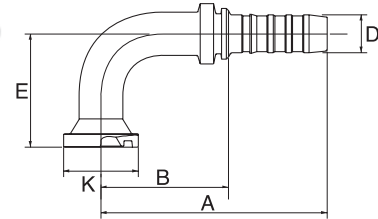

D				A B E K				KIT	KIT	REF.
-size	DN	"		mm	mm	mm	mm			GS
-8	12	1/2	1/2"	88.0	50.5	40.0	31.8	8 PH-FLH	8FLHCFM	8GS8FLH90M
-8	12	1/2	3/4"	88.0	50.5	58.0	41.3	12 PH-FLH	12FLHCFM	8GS12FLH90M
-10	16	5/8	1/2"	113.0	62.7	40.0	31.8	8 PH-FLH		10GS8FLH90M
-10	16	5/8	3/4"	110.0	59.7	58.0	41.3	12 PH-FLH	12FLHCFM	10GS12FLH90M
-12	20	3/4	3/4"	112.0	61.0	58.0	41.3	12 PH-FLH	12FLHCFM	12GS12FLH90M
-12	20	3/4	1"	132.0	81.0	70.0	47.6	16 PH-FLH	16FLHCFM	12GS16FLH90M
-16	25	1	3/4"	135.0	78.6	58.0	41.3	12 PH-FLH		16GS12FLH90M
-16	25	1	1"	135.0	78.6	70.0	47.6	16 PH-FLH	16FLHCFM	16GS16FLH90M
-16	25	1	1.1/4"	134.0	76.8	90.0	54.0	20 PH-FLH	20FLHCFM	16GS20FLH90M
-20	32	1.1/4	1"	160.0	88.9	70.0	47.6	16 PH-FLH		20GS16FLH90M
-20	32	1.1/4	1.1/4"	165.0	93.9	90.0	54.0	20 PH-FLH	20FLHCFM	20GS20FLH90M

M: Medium drop per ISO 12151-3. / Details on flange kits see page 292.

Unless otherwise stated the coupling meets the pressure rating requirements of the respective international standard.

COUPLINGS FOR WIRE SPIRAL HYDRAULIC HOSES GLOBALSPIRAL

SAE FLH90L

SAE 'O' ring flange high-pressure. Code 62.
90° swept elbow. Long drop.

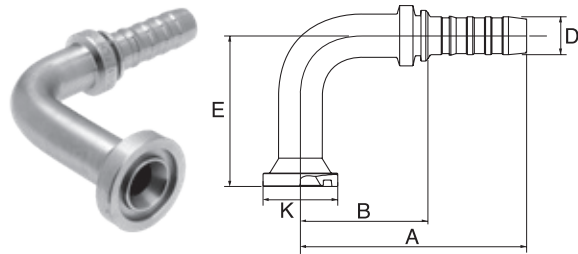

↻			⊕	↔						
D				A	B	E	K	KIT	KIT	REF.
-size	DN	"		mm	mm	mm	mm			GS
-12	20	3/4	3/4"	112.0	61.0	100.0	41.3	12 PH-FLH	12FLHCFM	12GS12FLH90-100
-16	25	1	1"	135.0	78.2	100.0	47.6	16 PH-FLH	16FLHCFM	16GS16FLH90-100
-16	25	1	1"	134.0	77.6	120.0	47.6	16 PH-FLH	16FLHCFM	16GS16FLH90-120
-20	32	1.1/4	1"	160.0	88.9	100.0	47.6	16 PH-FLH		20GS16FLH90-100
-20	32	1.1/4	1.1/4"	165.0	93.9	120.0	54.0	20 PH-FLH		20GS20FLH90-120
-20	32	1.1/4	1.1/2"	169.0	97.9	150.0	63.5	24 PH-FLH	24FLHCFM	20GS24FLH90-150

Details on flange kits see page 292.

FLK

Komatsu type 'O' ring flange.

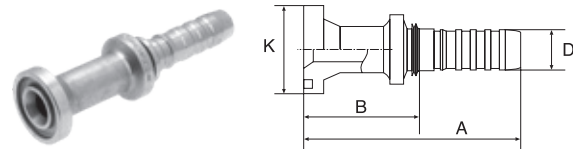

↻			⊕	↔					
D				A	B	K			REF.
-size	DN	"		mm	mm	mm			GS
-8	12	1/2	5/8"	81.5	44.1	34.2			8GS10FLK
-10	16	5/8	5/8"	114.0	63.7	34.2			10GS10FLK
-12	20	3/4	5/8"	110.0	59.0	34.2			12GS10FLK

FLK45

Komatsu type 'O' ring flange.
45° swept elbow.

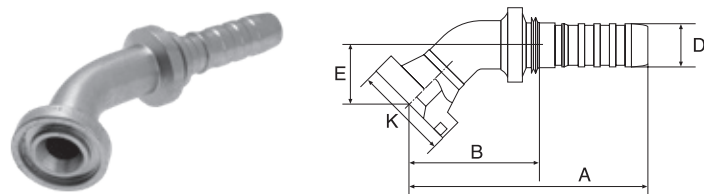

↻			⊕	↔					
D				A	B	E	K		REF.
-size	DN	"		mm	mm	mm	mm		GS
-10	16	5/8	5/8"	121.0	70.7	26.0	34.2		10GS10FLK45-026

Unless otherwise stated the coupling meets the pressure rating requirements of the respective international standard.

COUPLINGS FOR WIRE SPIRAL HYDRAULIC HOSES GLOBALSPIRAL

THE WORLD OF COUPLINGS

FLK90

Komatsu type 'O' ring flange.
90° swept elbow.

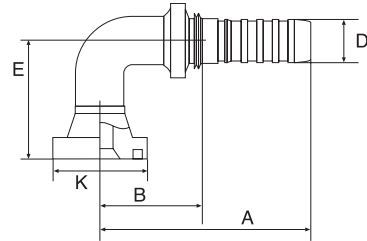

D				A B E K			REF.	
-size	DN	"		mm	mm	mm	mm	GS
-10	16	5/8	5/8"	110.0	59.7	55.0	34.2	10GS10FLK90-055
-12	20	3/4	5/8"	118.0	67.0	55.0	34.2	12GS10FLK90-055

FLC

Caterpillar type 'O' ring flange.

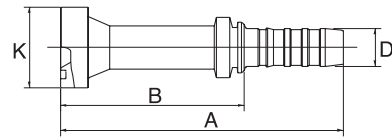

D				A B K			REF.
-size	DN	"		mm	mm	mm	GS
-12	20	3/4	3/4"	145.0	94.0	41.3	12GS12FLC
-12	20	3/4	1"	145.0	94.0	47.6	12GS16FLC
-16	25	1	1"	155.0	98.2	47.6	16GS16FLC
-16	25	1	1.1/4"	155.0	98.2	54.0	16GS20FLC
-20	32	1.1/4	1.1/4"	187.0	115.9	54.0	20GS20FLC
-20	32	1.1/4	1.1/2"	187.0	115.9	63.5	20GS24FLC

-24 size is 42.0 MPa (6000 psi). / Note: FLC flanges are designed with a thicker flange head. The 14.2 mm flange dimension is frequently found on Caterpillar equipment. This flange lets the user utilise the Caterpillar flange clamp halves where practical when he replaces the hose assembly. At the user's option, standard Code 62 flanges and flange clamp halves can be used in place of the Caterpillar flanges and flange clamp halves. The standard Code 62 flange head thickness ranges between 7.8 and 12.7 mm.

Unless otherwise stated the coupling meets the pressure rating requirements of the respective international standard.

COUPLINGS FOR WIRE SPIRAL HYDRAULIC HOSES GLOBALSPIRAL

FLC22

Caterpillar type 'O' ring flange.
22° swept elbow.

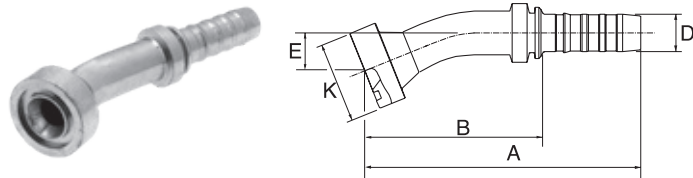

↔			⊞	↔				⊞
D				A	B	E	K	REF.
-size	DN	"		mm	mm	mm	mm	GS
-12	20	3/4	3/4"	143.0	92.0	16.0	41.3	12GS12FLC22-016
-16	25	1	1"	153.0	95.9	17.0	47.6	16GS16FLC22-017
-16	25	1	1.1/4"	153.0	95.9	17.0	54.0	16GS20FLC22-017
-20	32	1.1/4	1.1/4"	185.0	113.9	17.0	54.0	20GS20FLC22-017
-20	32	1.1/4	1.1/2"	185.0	113.9	17.0	63.5	20GS24FLC22-017

-24 size is 42.0 MPa (6000 psi). / Note: FLC flanges are designed with a thicker flange head. The 14.2 mm flange dimension is frequently found on Caterpillar equipment. This flange lets the user utilise the Caterpillar flange clamp halves where practical when he replaces the hose assembly. At the user's option, standard Code 62 flanges and flange clamp halves can be used in place of the Caterpillar flanges and flange clamp halves. The standard Code 62 flange head thickness ranges between 7.8 and 12.7 mm.

FLC30

Caterpillar type 'O' ring flange.
30° swept elbow.

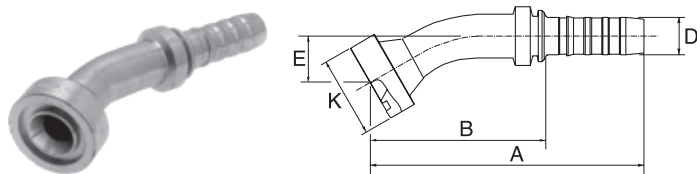

↔			⊞	↔				⊞
D				A	B	E	K	REF.
-size	DN	"		mm	mm	mm	mm	GS
-12	20	3/4	3/4"	140.0	89.0	22.0	41.3	12GS12FLC30-022
-12	20	3/4	1"	141.0	90.0	22.0	47.6	12GS16FLC30-022
-16	25	1	1"	151.0	93.7	23.0	47.6	16GS16FLC30-023
-16	25	1	1.1/4"	151.0	93.7	23.0	54.0	16GS20FLC30-023
-20	32	1.1/4	1.1/4"	183.0	111.9	24.0	54.0	20GS20FLC30-024
-20	32	1.1/4	1.1/2"	183.0	111.9	24.0	63.5	20GS24FLC30-024

-24 size is 42.0 MPa (6000 psi). / Note: FLC flanges are designed with a thicker flange head. The 14.2 mm flange dimension is frequently found on Caterpillar equipment. This flange lets the user utilise the Caterpillar flange clamp halves where practical when he replaces the hose assembly. At the user's option, standard Code 62 flanges and flange clamp halves can be used in place of the Caterpillar flanges and flange clamp halves. The standard Code 62 flange head thickness ranges between 7.8 and 12.7 mm.

Unless otherwise stated the coupling meets the pressure rating requirements of the respective international standard.

COUPLINGS FOR WIRE SPIRAL HYDRAULIC HOSES GLOBALSPIRAL

THE WORLD OF COUPLINGS

FLC45

Caterpillar type 'O' ring flange.
45° swept elbow.

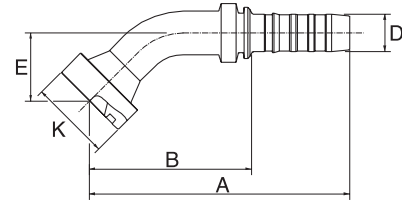

D				A B E K				REF.
-size	DN	"		mm	mm	mm	mm	GS
-12	20	3/4	3/4"	133.0	82.0	35.0	41.3	12GS12FLC45-035
-12	20	3/4	1"	133.0	82.0	35.0	47.6	12GS16FLC45-035
-16	25	1	1"	143.0	86.3	37.0	47.6	16GS16FLC45-037
-16	25	1	1.1/4"	143.0	86.3	37.0	54.0	16GS20FLC45-037
-20	32	1.1/4	1.1/4"	176.0	104.9	37.0	54.0	20GS20FLC45-037
-20	32	1.1/4	1.1/2"	176.0	104.9	37.0	63.5	20GS24FLC45-037

-24 size is 42.0 MPa (6000 psi). / Note: FLC flanges are designed with a thicker flange head. The 14.2 mm flange dimension is frequently found on Caterpillar equipment. This flange lets the user utilise the Caterpillar flange clamp halves where practical when he replaces the hose assembly. At the user's option, standard Code 62 flanges and flange clamp halves can be used in place of the Caterpillar flanges and flange clamp halves. The standard Code 62 flange head thickness ranges between 7.8 and 12.7 mm.

FLC60

Caterpillar type 'O' ring flange.
60° swept elbow.

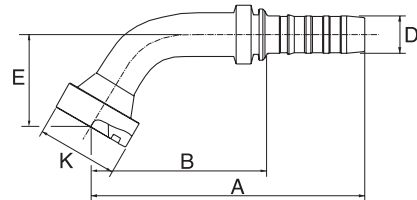

D				A B E K				REF.
-size	DN	"		mm	mm	mm	mm	GS
-12	20	3/4	1"	146.0	95.0	48.0	47.6	12GS16FLC60-048
-16	25	1	1"	163.0	106.0	50.0	47.6	16GS16FLC60-050
-16	25	1	1.1/4"	163.0	106.0	50.0	54.0	16GS20FLC60-050
-20	32	1.1/4	1.1/4"	198.0	126.9	52.0	54.0	20GS20FLC60-052
-20	32	1.1/4	1.1/2"	198.0	126.9	52.0	63.5	20GS24FLC60-052

-24 size is 42.0 MPa (6000 psi). / Note: FLC flanges are designed with a thicker flange head. The 14.2 mm flange dimension is frequently found on Caterpillar equipment. This flange lets the user utilise the Caterpillar flange clamp halves where practical when he replaces the hose assembly. At the user's option, standard Code 62 flanges and flange clamp halves can be used in place of the Caterpillar flanges and flange clamp halves. The standard Code 62 flange head thickness ranges between 7.8 and 12.7 mm.

Unless otherwise stated the coupling meets the pressure rating requirements of the respective international standard.

COUPLINGS FOR WIRE SPIRAL HYDRAULIC HOSES GLOBALSPIRAL

FLC67

Caterpillar type 'O' ring flange.
67° swept elbow.

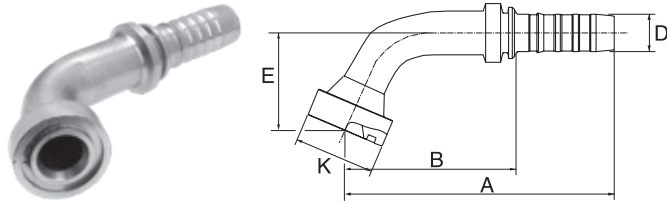

↔			⊕	↔				⊕
D				A	B	E	K	REF.
-size	DN	"		mm	mm	mm	mm	GS
-16	25	1	1"	156.0	99.0	57.0	47.6	16GS16FLC67-057
-16	25	1	1.1/4"	156.0	99.0	57.0	54.0	16GS20FLC67-057
-20	32	1.1/4	1.1/4"	191.0	119.9	59.0	54.0	20GS20FLC67-059
-20	32	1.1/4	1.1/2"	191.0	119.9	59.0	63.5	20GS24FLC67-059

-24 size is 42.0 MPa (6000 psi). / Note: FLC flanges are designed with a thicker flange head. The 14.2 mm flange dimension is frequently found on Caterpillar equipment. This flange lets the user utilise the Caterpillar flange clamp halves where practical when he replaces the hose assembly. At the user's option, standard Code 62 flanges and flange clamp halves can be used in place of the Caterpillar flanges and flange clamp halves. The standard Code 62 flange head thickness ranges between 7.8 and 12.7 mm.

FLC90

Caterpillar type 'O' ring flange.
90° swept elbow.

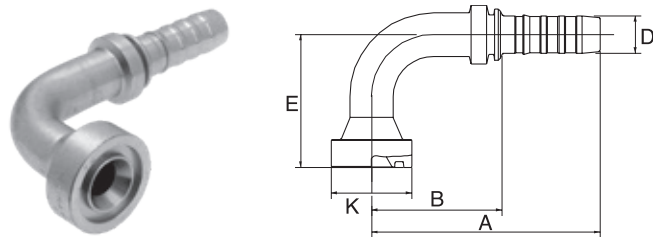

↔			⊕	↔				⊕
D				A	B	E	K	REF.
-size	DN	"		mm	mm	mm	mm	GS
-12	20	3/4	3/4"	125.0	74.0	68.0	41.3	12GS12FLC90-068
-12	20	3/4	3/4"	117.0	66.0	128.0	41.3	12GS12FLC90-128
-12	20	3/4	1"	128.0	77.0	68.0	47.6	12GS16FLC90-068
-16	25	1	1"	131.0	74.1	74.0	47.6	16GS16FLC90-074
-16	25	1	1"	131.0	74.1	132.0	47.6	16GS16FLC90-132
-16	25	1	1.1/4"	131.0	74.1	74.0	54.0	16GS20FLC90-074
-20	32	1.1/4	1.1/4"	166.0	94.9	77.0	54.0	20GS20FLC90-077
-20	32	1.1/4	1.1/2"	166.0	94.9	77.0	63.5	20GS24FLC90-077

-24 size is 42.0 MPa (6000 psi). / Note: FLC flanges are designed with a thicker flange head. The 14.2 mm flange dimension is frequently found on Caterpillar equipment. This flange lets the user utilise the Caterpillar flange clamp halves where practical when he replaces the hose assembly. At the user's option, standard Code 62 flanges and flange clamp halves can be used in place of the Caterpillar flanges and flange clamp halves. The standard Code 62 flange head thickness ranges between 7.8 and 12.7 mm.

Unless otherwise stated the coupling meets the pressure rating requirements of the respective international standard.

COUPLINGS FOR WIRE SPIRAL HYDRAULIC HOSES GLOBALSPIRAL

THE WORLD OF COUPLINGS

DIN 24° FDLORX

Female DIN 'O' ring swivel. 24° cone.
Light series.

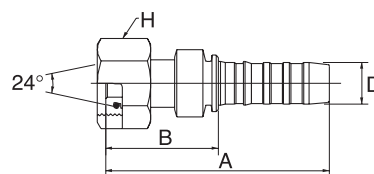

↔			🌀	↔	🌀		
D				A	B	H	REF.
-size	DN	"		mm	mm	mm	GS
-6	10	3/8	M18 x 1.5	73.0	37.2	22.0	6GS12FDLORX
-8	12	1/2	M22 x 1.5	73.0	35.5	27.0	8GS15FDLORX
-10	16	5/8	M26 x 1.5	91.8	41.5	32.0	10GS18FDLORX
-12	20	3/4	M30 x 2.0	97.0	46.0	36.0	12GS22FDLORX
-12	20	3/4	M36 x 2.0	99.0	48.0	41.0	12GS28FDLORX
-16	25	1	M36 x 2.0	105.0	48.6	41.0	16GS28FDLORX
-20	32	1.1/4	M45 x 2.0	132.5	61.4	50.0	20GS35FDLORX
-24	40	1.1/2	M52 x 2.0	135.7	62.0	60.0	24GSP42FDLORX

-6 to -20 size are 42.0 MPa (6000 psi).

DIN 24° FDLORX45

Female DIN 'O' ring swivel. 24° cone.
Light series. 45° swept elbow.

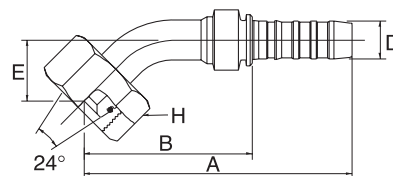

↔			🌀	↔	🌀			
D				A	B	E	H	REF.
-size	DN	"		mm	mm	mm	mm	GS
-8	12	1/2	M22 x 1.5	94.7	57.2	20.2	27.0	8GS15FDLORX45
-12	20	3/4	M30 x 2.0	135.8	84.8	29.8	36.0	12GS22FDLORX45
-16	25	1	M36 x 2.0	155.5	99.1	30.9	41.0	16GS28FDLORX45
-24	40	1.1/2	M52 x 2.0	208.9	135.2	44.0	60.0	24GSP42FDLORX45

-8 to -16 size are 42.0 MPa (6000 psi).

Unless otherwise stated the coupling meets the pressure rating requirements of the respective international standard.

COUPLINGS FOR WIRE SPIRAL HYDRAULIC HOSES GLOBALSPIRAL

DIN 24° FDLORX90

Female DIN 'O' ring swivel. 24° cone.
Light series. 90° swept elbow.

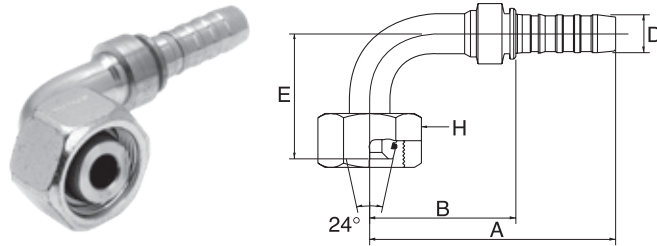

↻			🌀	↔	🌀			REF.
-size	DN	"		A	B	E	H	GS
-6	10	3/8	M18 x 1.5	78.0	42.2	37.0	22.0	6GS12FDLORX90
-8	12	1/2	M22 x 1.5	88.0	50.5	42.0	27.0	8GS15FDLORX90
-10	16	5/8	M26 x 1.5	113.5	63.2	51.5	32.0	10GS18FDLORX90
-12	20	3/4	M30 x 2.0	126.0	75.0	62.0	36.0	12GS22FDLORX90
-16	25	1	M36 x 2.0	151.0	94.6	70.0	41.0	16GS28FDLORX90
-24	40	1.1/2	M52 x 2.0	194.6	120.9	92.0	60.0	24GSP42FDLORX90

-6 to -16 size are 42.0 MPa (6000 psi).

DIN 24° MDL

Male DIN parallel. 24° inverted cone.
Light series.

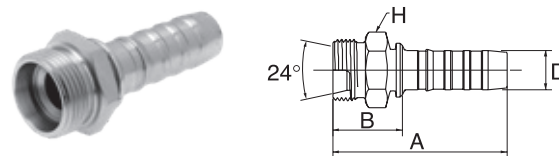

↻			🌀	↔	🌀			REF.
-size	DN	"		A	B	H	GS	
-6	10	3/8	M18 x 1.5	60.0	24.2	19.0	6GS12MDL	
-8	12	1/2	M22 x 1.5	63.0	25.5	24.0	8GS15MDL	
-10	16	5/8	M26 x 1.5	76.5	26.2	27.0	10GS18MDL	
-12	20	3/4	M30 x 2.0	79.5	28.5	32.0	12GS22MDL	
-16	25	1	M36 x 2.0	90.0	33.2	41.0	16GS28MDL	
-24	40	1.1/2	M52 x 2.0	120.0	46.4	55.0	24GSP42MDL	

-6 to -16 size are 42.0 MPa (6000 psi).

Unless otherwise stated the coupling meets the pressure rating requirements of the respective international standard.

COUPLINGS FOR WIRE SPIRAL HYDRAULIC HOSES GLOBALSPIRAL

THE WORLD OF COUPLINGS

DIN 24° FDHORX

Female DIN 'O' ring swivel. 24° cone.
Heavy series.

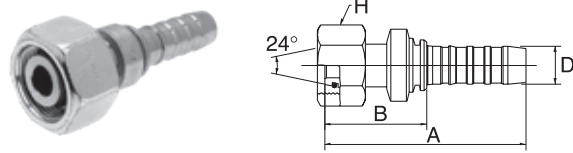

↔			🌀	↔	🌀		
D				A	B	H	REF.
-size	DN	"		mm	mm	mm	GS
-6	10	3/8	M20 x 1.5	73.0	37.2	24.0	6GS12FDHORX
-6	10	3/8	M22 x 1.5	75.5	39.7	27.0	6GS14FDHORX
-8	12	1/2	M22 x 1.5	76.5	38.9	27.0	8GS14FDHORX
-8	12	1/2	M24 x 1.5	79.0	41.5	30.0	8GS16FDHORX
-8	12	1/2	M30 x 2.0	82.0	44.5	36.0	8GS20FDHORX
-10	16	5/8	M30 x 2.0	100.0	49.7	36.0	10GS20FDHORX
-10	16	5/8	M36 x 2.0	104.0	53.7	46.0	10GS25FDHORX
-12	20	3/4	M30 x 2.0	103.0	52.0	36.0	12GS20FDHORX
-12	20	3/4	M36 x 2.0	107.4	56.4	46.0	12GS25FDHORX
-12	20	3/4	M42 x 2.0	97.0	46.0	50.0	12GS30FDHORX
-16	25	1	M36 x 2.0	116.0	59.6	46.0	16GS25FDHORX
-16	25	1	M42 x 2.0	118.0	61.6	50.0	16GS30FDHORX
-20	32	1.1/4	M52 x 2.0	145.0	73.9	60.0	20GS38FDHORX
-24	40	1.1/2	M52 x 2.0	150.0	76.4	60.0	24GSP38FDHORX

-6 to -20 size are 42.0 MPa (6000 psi).

DIN 24° FDHORX45

Female DIN 'O' ring swivel. 24° cone.
Heavy series. 45° swept elbow.

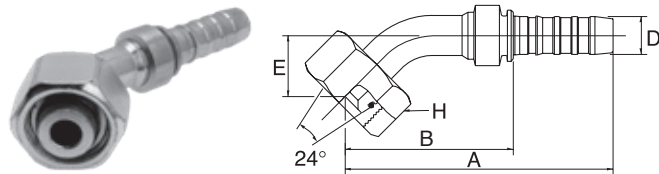

↔			🌀	↔	🌀			
D				A	B	E	H	REF.
-size	DN	"		mm	mm	mm	mm	GS
-6	10	3/8	M20 x 1.5	86.7	50.8	18.9	24.0	6GS12FDHORX45
-6	10	3/8	M22 x 1.5	88.8	53.0	21.0	27.0	6GS14FDHORX45
-8	12	1/2	M24 x 1.5	96.1	58.7	21.6	30.0	8GS16FDHORX45
-10	16	5/8	M30 x 2.0	121.6	71.3	24.9	36.0	10GS20FDHORX45
-12	20	3/4	M30 x 2.0	160.9	109.9	29.8	36.0	12GS20FDHORX45
-12	20	3/4	M36 x 2.0	137.3	86.3	31.2	46.0	12GS25FDHORX45
-16	25	1	M36 x 2.0	159.7	103.3	35.1	46.0	16GS25FDHORX45
-16	25	1	M42 x 2.0	159.7	103.3	35.1	50.0	16GS30FDHORX45
-20	32	1.1/4	M52 x 2.0	196.0	124.9	42.5	60.0	20GS38FDHORX45
-24	40	1.1/2	M52 x 2.0	208.9	135.2	44.0	60.0	24GSP38FDHORX45

-6 to -20 size are 42.0 MPa (6000 psi).

Unless otherwise stated the coupling meets the pressure rating requirements of the respective international standard.

COUPLINGS FOR WIRE SPIRAL HYDRAULIC HOSES GLOBALSPIRAL

DIN 24° FDHORX90

Female DIN 'O' ring swivel. 24° cone.
Heavy series. 90° swept elbow.

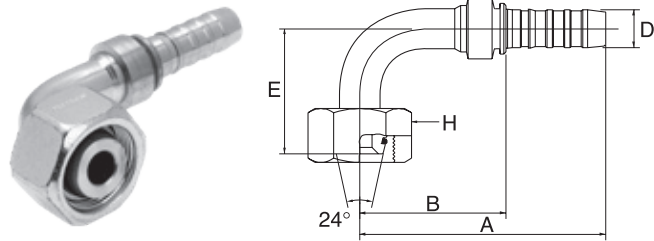

↻			🌀	↔	🔧			
D				A	B	E	H	REF.
-size	DN	"		mm	mm	mm	mm	GS
-6	10	3/8	M20 x 1.5	78.0	42.2	37.0	24.0	6GS12FDHORX90
-6	10	3/8	M22 x 1.5	78.0	42.2	40.0	27.0	6GS14FDHORX90
-8	12	1/2	M24 x 1.5	88.0	50.5	44.0	30.0	8GS16FDHORX90
-10	16	5/8	M30 x 2.0	112.5	62.2	51.0	36.0	10GS20FDHORX90
-12	20	3/4	M30 x 2.0	126.0	75.0	62.0	36.0	12GS20FDHORX90
-12	20	3/4	M36 x 2.0	126.0	75.0	64.0	46.0	12GS25FDHORX90
-16	25	1	M36 x 2.0	151.0	94.6	76.0	46.0	16GS25FDHORX90
-16	25	1	M42 x 2.0	151.0	94.6	76.0	50.0	16GS30FDHORX90
-20	32	1.1/4	M52 x 2.0	180.5	109.4	87.0	60.0	20GS38FDHORX90
-24	40	1.1/2	M52 x 2.0	194.6	121.0	92.0	60.0	24GSP38FDHORX90

-6 to -20 size are 42.0 MPa (6000 psi).

DIN 24° MDH

Male DIN parallel. 24° inverted cone.
Heavy series.

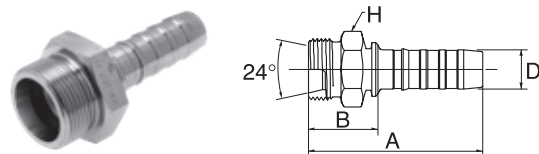

↻			🌀	↔	🔧		
D				A	B	H	REF.
-size	DN	"		mm	mm	mm	GS
-6	10	3/8	M20 x 1.5	63.7	27.9	22.0	6GS12MDH
-6	10	3/8	M22 x 1.5	65.7	29.9	24.0	6GS14MDH
-8	12	1/2	M24 x 1.5	67.5	30.0	27.0	8GS16MDH
-10	16	5/8	M30 x 2.0	85.0	34.7	32.0	10GS20MDH
-12	20	3/4	M30 x 2.0	85.0	34.0	32.0	12GS20MDH
-12	20	3/4	M36 x 2.0	89.0	38.0	41.0	12GS25MDH
-12	20	3/4	M42 x 2.0	95.0	44.0	46.0	12GS30MDH
-16	25	1	M36 x 2.0	97.0	40.2	41.0	16GS25MDH
-16	25	1	M42 x 2.0	99.0	42.2	46.0	16GS30MDH
-20	32	1.1/4	M52 x 2.0	123.0	51.9	55.0	20GS38MDH

-6 to -20 size are 42.0 MPa (6000 psi).

Unless otherwise stated the coupling meets the pressure rating requirements of the respective international standard.

COUPLINGS FOR WIRE SPIRAL HYDRAULIC HOSES GLOBALSPIRAL

THE WORLD OF COUPLINGS

NPTF MP

Male NPTF pipe.

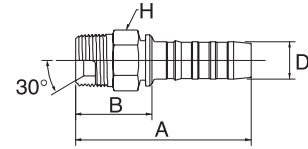

↔			🌀	↔	🌀		
D				A	B	H	REF.
-size	DN	"		mm	mm	mm	GS
-6	10	3/8	3/8" - 18 NPTF	69.0	33.2	17.5	6GS6MP
-6	10	3/8	1/2" - 14 NPTF	73.0	37.2	22.2	6GS8MP
-8	12	1/2	1/2" - 14 NPTF	74.0	36.5	22.2	8GS8MP
-8	12	1/2	3/4" - 14 NPTF	77.0	39.5	27.0	8GS12MP
-10	16	5/8	1/2" - 14 NPTF	87.0	36.7	23.8	10GS8MP
-10	16	5/8	3/4" - 14 NPTF	91.0	40.7	28.6	10GS12MP
-12	20	3/4	3/4" - 14 NPTF	90.0	39.0	27.0	12GS12MP
-12	20	3/4	1" - 11.5 NPTF	97.0	46.0	34.9	12GS16MP
-16	25	1	3/4" - 14 NPTF	101.0	44.2	34.9	16GS12MP
-16	25	1	1" - 11.5 NPTF	106.0	49.2	34.9	16GS16MP
-16	25	1	1.1/4" - 11.5 NPTF	109.0	52.2	44.5	16GS20MP
-20	32	1.1/4	1.1/4" - 11.5 NPTF	127.0	55.9	44.5	20GS20MP
-24	40	1.1/2	1.1/2" - 11.5 NPTF	133.0	59.4	50.8	24GSP24MP
-32	50	2	2" - 11.5 NPTF	153.7	61.7	63.5	32GSP32MP

-6 to -20 size are 42.0 MPa (6000 psi); -24 size is 24.5 MPa (3500 psi); -32 size is 17.5 MPa (2500 psi). / Warning: Use only in NPTF connections. Do not use in oil field (API) connections. Blow apart of an oil field connection can result in serious injuries.

UNF MB

Male SAE 'O' ring boss. SAE J1926/2.
ISO 11926/2 heavy duty (S series).

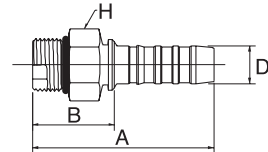

↔			🌀	↔	🌀		
D				A	B	H	REF.
-size	DN	"		mm	mm	mm	GS
-6	10	3/8	9/16" - 18 UNF	65.0	29.2	17.5	6GS6MB
-8	12	1/2	3/4" - 16 UNF	70.0	32.6	22.2	8GS8MB
-8	12	1/2	7/8" - 14 UNF	72.0	34.5	25.4	8GS10MB
-10	16	5/8	7/8" - 14 UNF	88.0	37.7	25.4	10GS10MB
-10	16	5/8	1.1/16" - 12 UN	88.0	37.7	31.8	10GS12MB
-12	20	3/4	1.1/16" - 12 UN	93.0	42.0	31.8	12GS12MB
-12	20	3/4	1.5/16" - 12 UN	90.0	39.0	38.1	12GS16MB
-16	25	1	1.5/16" - 12 UN	98.0	41.2	38.1	16GS16MB
-20	32	1.1/4	1.5/8" - 12 UN	115.0	43.9	47.6	20GS20MB

-6 to -20 size are 42.0 MPa (6000 psi).

Unless otherwise stated the coupling meets the pressure rating requirements of the respective international standard.

COUPLINGS FOR WIRE SPIRAL HYDRAULIC HOSES GLOBALSPIRAL

FG FFGX

Female French Gaz swivel. 24° cone.

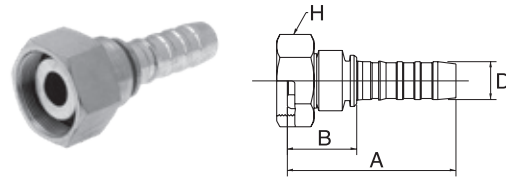

D				A B H			REF. GS
-size	DN	"		mm	mm	mm	
-8	12	1/2	M24 x 1.5	68.0	30.5	30.0	8GS17FFGX
-10	16	5/8	M30 x 1.5	82.5	32.2	36.0	10GS21FFGX
-12	20	3/4	M36 x 1.5	87.5	36.5	41.0	12GS27FFGX
-16	25	1	M45 x 1.5	95.5	39.1	55.0	16GS34FFGX

-8 to -16 size are 35.0 MPa (5000 psi).

FG FFGX90

Female French Gaz swivel. 24° cone.
90° swept elbow.

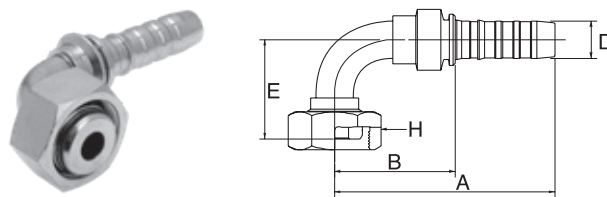

D				A B E H				REF. GS
-size	DN	"		mm	mm	mm	mm	
-8	12	1/2	M24 x 1.5	76.1	38.7	37.8	30.0	8GS17FFGX90
-10	16	5/8	M30 x 1.5	92.0	41.7	45.0	36.0	10GS21FFGX90

-8 to -10 size are 35.0 MPa (5000 psi).

FG MFG

Male French Gaz parallel. 24° inverted cone.

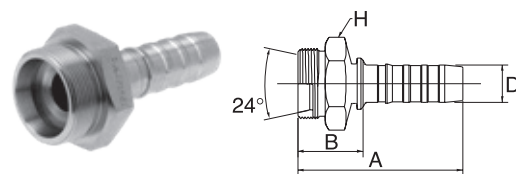

D				A B H			REF. GS
-size	DN	"		mm	mm	mm	
-8	12	1/2	M24 x 1.5	66.5	29.0	27.0	8GS17MFG
-10	16	5/8	M30 x 1.5	82.0	31.7	32.0	10GS21MFG
-12	20	3/4	M36 x 1.5	84.5	33.5	41.0	12GS27MFG
-16	25	1	M45 x 1.5	94.0	37.2	46.0	16GS34MFG

-8 to -16 size are 35.0 MPa (5000 psi).

Unless otherwise stated the coupling meets the pressure rating requirements of the respective international standard.

COUPLINGS FOR WIRE SPIRAL HYDRAULIC HOSES GLOBALSPIRAL

THE WORLD OF COUPLINGS

FG FPFL

Female French Gaz flange high-pressure.
24° Poclairn inverted cone.

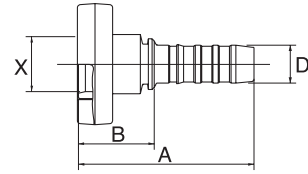

↔			↔			↔
D			X	A	B	REF.
-size	DN	"	mm	mm	mm	GS
-8	12	1/2	17.0	69.0	31.5	8GS17FPFL
-10	16	5/8	21.0	85.0	34.7	10GS21FPFL
-12	20	3/4	27.0	91.0	40.0	12GS27FPFL
-16	25	1	34.0	102.0	45.2	16GS34FPFL
-20	32	1.1/4	42.0	133.0	61.9	20GS42FPFL

-8 to -20 size are 35.0 MPa (5000 psi).

FG MPFL

Male French Gaz flange high-pressure.
24° Poclairn cone.

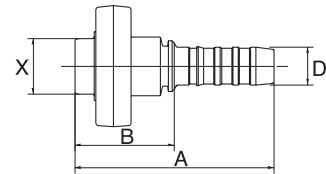

↔			↔			↔
D			X	A	B	REF.
-size	DN	"	mm	mm	mm	GS
-8	12	1/2	17.0	79.0	41.5	8GS17MPFL
-10	16	5/8	21.0	95.0	44.7	10GS21MPFL
-12	20	3/4	27.0	102.0	51.0	12GS27MPFL
-16	25	1	34.0	116.0	59.2	16GS34MPFL
-20	32	1.1/4	42.0	172.0	100.9	20GS42MPFL

-8 to -20 size are 35.0 MPa (5000 psi).

Unless otherwise stated the coupling meets the pressure rating requirements of the respective international standard.

COUPLINGS FOR WIRE SPIRAL HYDRAULIC HOSES

GLOBALSPIRAL

FG MPFL90

Male French Gaz flange high-pressure.
24° Poclair cone. 90° swept elbow.

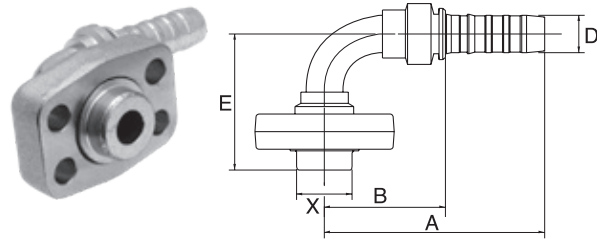

↻			↔				🌀
D			X	A	B	E	REF.
-size	DN	"	mm	mm	mm	mm	GS
-10	16	5/8	21.0	92.0	41.7	57.8	10GS21MPFL90
-12	20	3/4	27.0	100.3	49.3	68.8	12GS27MPFL90
-16	25	1	34.0	126.3	69.5	89.3	16GS34MPFL90
-20	32	1.1/4	42.0	149.9	78.7	89.4	20GS42MPFL90

-10 to -20 size are 35.0 MPa (5000 psi).

KOBELCO MKB

Male Kobelco type.

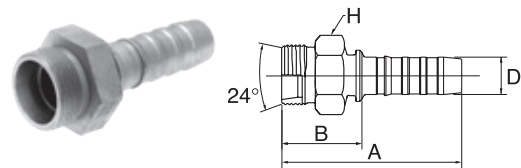

↻			🌀	↔			🌀
D				A	B	H	REF.
-size	DN	"		mm	mm	mm	GS
-12	20	3/4	M30 x 1.5	85.0	34.0	36.0	12GS22MKB
-12	20	3/4	M36 x 1.5	92.0	41.0	41.0	12GS28MKB
-16	25	1	M36 x 1.5	101.0	44.2	50.0	16GS28MKB
-16	25	1	M45 x 1.5	95.0	38.2	50.0	16GS35MKB

Unless otherwise stated the coupling meets the pressure rating requirements of the respective international standard.

COUPLINGS FOR WIRE SPIRAL HYDRAULIC HOSES GLOBALSPIRAL

THE WORLD OF COUPLINGS

HLE

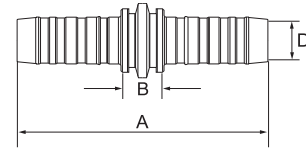

↔			↔		
-size	D	"	A	B	REF.
	DN		mm	mm	GS
-8	12	1/2	94.0	19.1	8GS8HLE
-12	20	3/4	163.0	61.0	12GS12HLE
-16	25	1	180.0	66.4	16GS16HLE
-20	32	1.1/4	172.0	29.8	20GS20HLE

HLE 90

90° swept elbow.

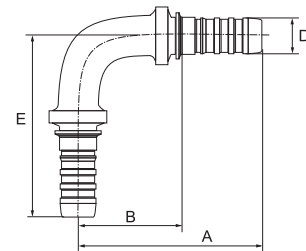

↔			↔			
-size	D	"	A	B	E	REF.
	DN		mm	mm	mm	GS
-8	12	1/2	86.0	48.5	86.0	8GS8HLE90-086
-12	20	3/4	128.8	77.8	128.8	12GS12HLE90-129
-16	25	1	127.0	70.2	127.0	16GS16HLE90-127
-20	32	1.1/4	155.0	83.9	155.0	20GS20HLE90-155

Unless otherwise stated the coupling meets the pressure rating requirements of the respective international standard.

THE WORLD OF COUPLINGS
INTEGRATED FLUID POWER SOLUTIONS



COUPLINGS FOR WIRE AND TEXTILE BRAIDED HOSES

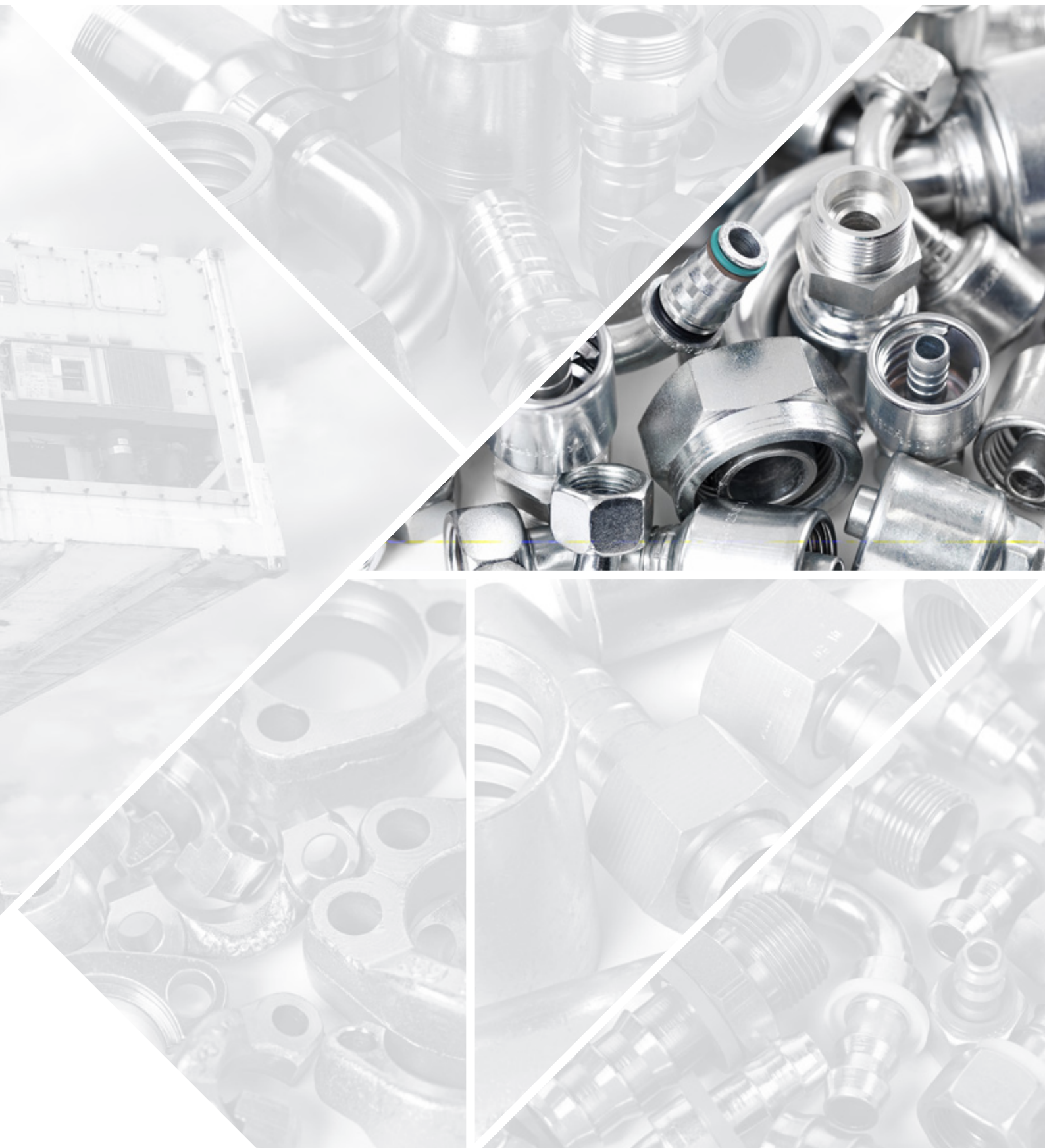

COUPLINGS FOR WIRE AND TEXTILE BRAIDED HOSES GLOBALSPIRAL PLUS

THE WORLD OF COUPLINGS

NO-SKIVE FERRULES

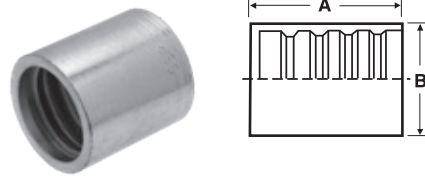

D			A	B	REF.
-size	DN	"	mm	mm	GSP
-24	40	1.1/2	75.8	70.0	24GSP1F-2
-32	50	2	90.0	83.5	32GSP1F-2

Note: Use GSP1F-2 only for wire braid hoses. For 6-spiral wire hose use 1-piece GSM coupling.

BSP FBSPORX

Female BSP 'O' ring swivel. 60° cone.

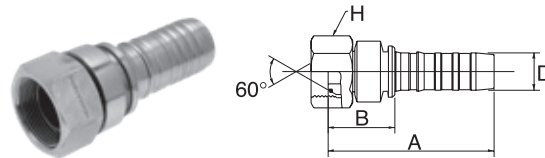

D				A	B	H	REF.
-size	DN	"		mm	mm	mm	GSP
-24	40	1.1/2	G 1.1/2" - 11 BSP	125.0	51.3	55.0	24GSP24FBSPORX
-32	50	2	G 2" - 11 BSP	153.0	61.0	70.0	32GSP32FBSPORX

BSP FBSPORX45

Female BSP 'O' ring swivel. 60° cone.
45° swept elbow.

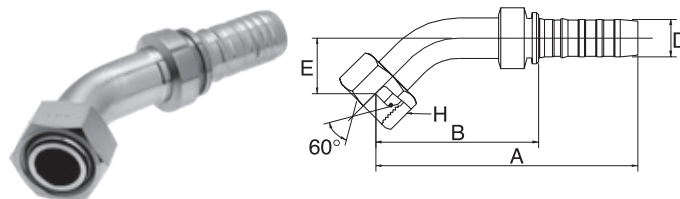

D				A	B	E	H	REF.
-size	DN	"		mm	mm	mm	mm	GSP
-24	40	1.1/2	G 1.1/2" - 11 BSP	214.5	140.9	49.7	55.0	24GSP24FBSPORX45
-32	50	2	G 2" - 11 BSP	276.1	184.1	62.3	70.0	32GSP32FBSPORX45

Unless otherwise stated the coupling meets the pressure rating requirements of the respective international standard.

COUPLINGS FOR WIRE AND TEXTILE BRAIDED HOSES

GLOBALSPIRAL PLUS

BSP FBSPORX90

Female BSP 'O' ring swivel. 60° cone. 90° swept elbow.

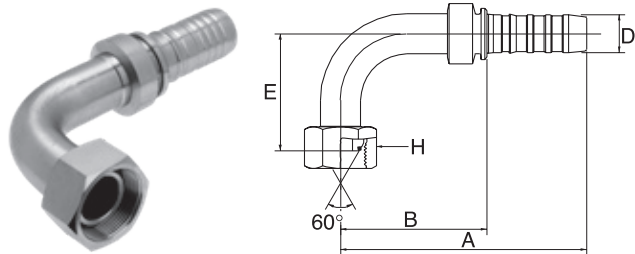

↻			🌀	↔	🌀			REF.
D				A	B	E	H	REF.
-size	DN	"		mm	mm	mm	mm	GSP
-24	40	1.1/2	G 1.1/2" - 11 BSP	194.6	121.0	100.0	55.0	24GSP24FBSPORX90
-32	50	2	G 2" - 11 BSP	254.7	162.7	129.1	70.0	32GSP32FBSPORX90

BSP MBSP

Male BSP parallel. 60° inverted cone.

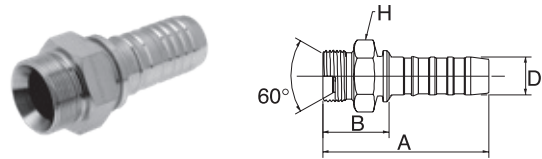

↻			🌀	↔	🌀			REF.
D				A	B	H	REF.	
-size	DN	"		mm	mm	mm	GSP	
-24	40	1.1/2	G 1.1/2" - 11 BSP	130.0	56.4	55.0	24GSP24MBSP	
-32	50	2	G 2" - 11 BSP	148.8	56.8	70.0	32GSP32MBSP	

JIC 37° FJX

Female JIC swivel. 37° inverted cone.

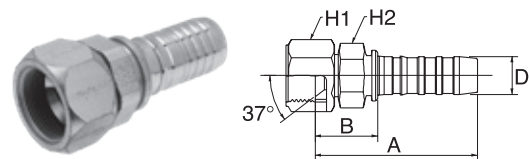

↻			🌀	↔	🌀			REF.
D				A	B	H1	H2	REF.
-size	DN	"		mm	mm	mm	mm	GSP
-24	40	1.1/2	1.7/8" - 12 UN	124.0	50.4	60.0	55.0	24GSP24FJX
-32	50	2	2.1/2" - 12 UN	148.0	56.0	75.0	65.0	32GSP32FJX

Unless otherwise stated the coupling meets the pressure rating requirements of the respective international standard.

COUPLINGS FOR WIRE AND TEXTILE BRAIDED HOSES GLOBALSPIRAL PLUS

THE WORLD OF COUPLINGS

JIC 37° FJX45

Female JIC swivel. 37° inverted cone.
45° swept elbow.

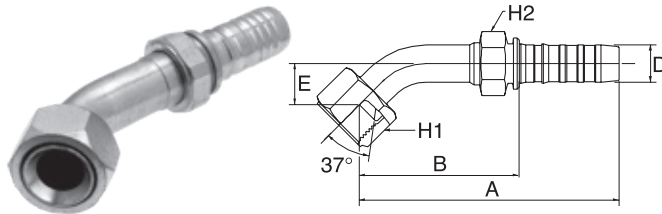

D				A	B	E	H1	H2	REF.
-size	DN	"		mm	mm	mm	mm	mm	GSP
-24	40	1.1/2	1.7/8" - 12 UN	233.0	159.5	50.0	60.0	55.0	24GSP24FJX45-050
-32	50	2	2.1/2" - 12 UN	267.0	175.5	65.0	75.0	65.0	32GSP32FJX45-065

JIC 37° FJX90

Female JIC swivel. 37° inverted cone.
90° swept elbow.

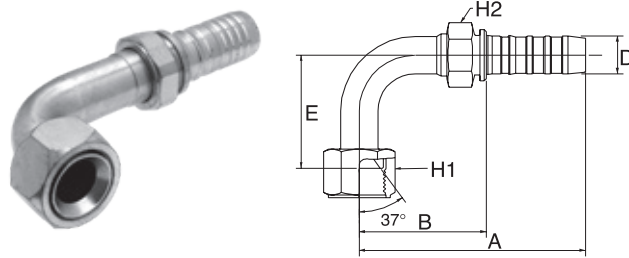

D				A	B	E	H1	H2	REF.
-size	DN	"		mm	mm	mm	mm	mm	GSP
-24	40	1.1/2	1.7/8" - 12 UN	212.0	138.4	89.0	60.0	55.0	24GSP24FJX90-089
-32	50	2	2.1/2" - 12 UN	272.0	179.7	140.0	75.0	65.0	32GSP32FJX90M

M: Medium drop per ISO 12151-5.

JIC 37° MJ

Male JIC parallel. 37° cone.

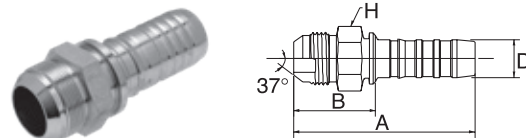

D				A	B	H	REF.
-size	DN	"		mm	mm	mm	GSP
-24	40	1.1/2	1.7/8" - 12 UN	130.0	56.4	50.0	24GSP24MJ
-32	50	2	2.1/2" - 12 UN	161.1	69.1	65.0	32GSP32MJ

Unless otherwise stated the coupling meets the pressure rating requirements of the respective international standard.

COUPLINGS FOR WIRE AND TEXTILE BRAIDED HOSES

GLOBALSPIRAL PLUS

SAE FFORX

Female SAE flat face 'O' ring swivel.

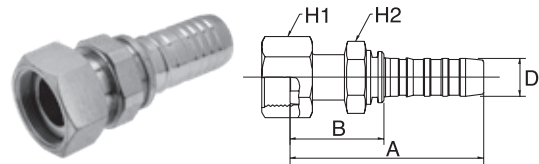

D				A B H1 H2			REF.	
-size	DN	"		mm	mm	mm	mm	GSP
-24	40	1.1/2	2" - 12 UN	137.0	63.4	60.0	55.0	24GSP24FFORX

SAE FL

SAE 'O' ring flange. Code 61.

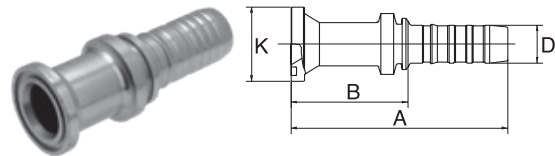

D				A B K			KIT	REF.
-size	DN	"		mm	mm	mm		GSP
-24	40	1.1/2	1.1/2"	152.9	79.3	60.3	24 PA-FL	24GSP24FL
-24	40	1.1/2	2"	152.9	79.3	71.4	32 PA-FL	24GSP32FL
-32	50	2	2"	159.3	67.3	71.4	32 PA-FL	32GSP32FL

Details on flange kits see page 292.

SAE FL30

SAE 'O' ring flange. Code 61.
30° swept elbow.

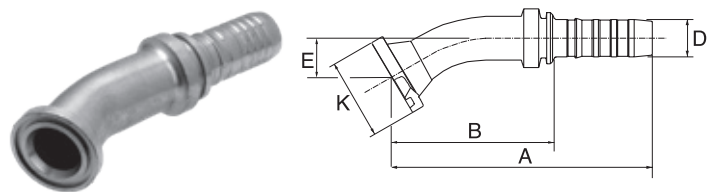

D				A B E K				KIT	REF.
-size	DN	"		mm	mm	mm	mm		GSP
-24	40	1.1/2	1.1/2"	209.0	135.2	25.0	60.3	24 PA-FL	24GSP24FL30S

Details on flange kits see page 292. / S: Short drop per ISO 12151-3.

Unless otherwise stated the coupling meets the pressure rating requirements of the respective international standard.

COUPLINGS FOR WIRE AND TEXTILE BRAIDED HOSES GLOBALSPIRAL PLUS

THE WORLD OF COUPLINGS

SAE FL45

SAE 'O' ring flange. Code 61.
45° swept elbow.

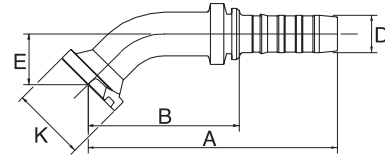

D			A B E K				KIT	REF.	
-size	DN	"	mm	mm	mm	mm	GSP		
-24	40	1.1/2	1.1/2"	202.0	128.6	38.0	60.3	24 PA-FL	24GSP24FL45S
-24	40	1.1/2	2"	200.0	126.3	52.0	71.4	32 PA-FL	24GSP32FL45S
-32	50	2	2"	257.0	165.0	66.0	71.4	32 PA-FL	32GSP32FL45-066

Details on flange kits see page 292. / S: Short drop per ISO 12151-3.

SAE FL60

SAE 'O' ring flange. Code 61.
60° swept elbow.

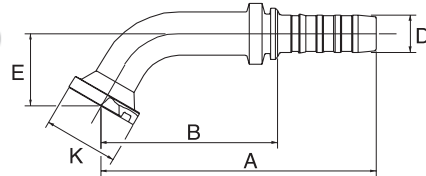

D			A B E K				KIT	REF.	
-size	DN	"	mm	mm	mm	mm	GSP		
-24	40	1.1/2	1.1/2"	231.0	157.5	53.0	60.3	24 PA-FL	24GSP24FL60S

Details on flange kits see page 292. / S: Short drop per ISO 12151-3.

SAE FL90

SAE 'O' ring flange. Code 61.
90° swept elbow.

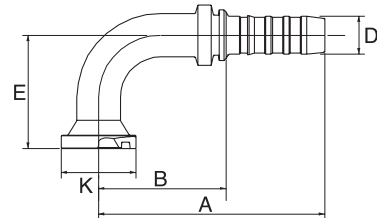

D			A B E K				KIT	REF.	
-size	DN	"	mm	mm	mm	mm	GSP		
-24	40	1.1/2	1.1/2"	184.0	109.9	81.0	60.3	24 PA-FL	24GSP24FL90S
-24	40	1.1/2	2"	175.0	101.9	80.0	71.4	32 PA-FL	24GSP32FL90-080
-32	50	2	2"	222.0	130.1	114.0	71.4	32 PA-FL	32GSP32FL90-114

Details on flange kits see page 292. / S: Short drop per ISO 12151-3.

Unless otherwise stated the coupling meets the pressure rating requirements of the respective international standard.

COUPLINGS FOR WIRE AND TEXTILE BRAIDED HOSES GLOBALSPIRAL PLUS

DIN 24° FDLORX

Female DIN 'O' ring swivel. 24° cone.
Light series.

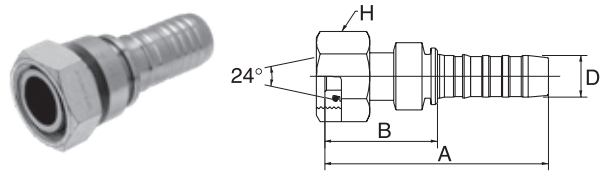

D			M52 x 2.0	A	B	H	REF.
-size	DN	"					
-24	40	1.1/2	M52 x 2.0	135.7	62.0	60.0	24GSP42FDLORX

DIN 24° FDLORX45

Female DIN 'O' ring swivel. 24° cone.
Light series. 45° swept elbow.

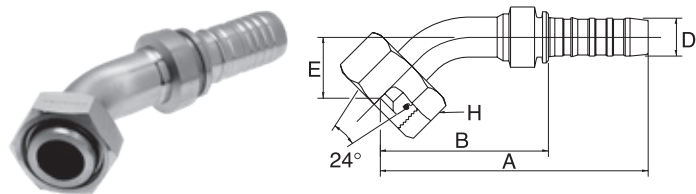

D			M52 x 2.0	A	B	E	H	REF.
-size	DN	"						
-24	40	1.1/2	M52 x 2.0	208.9	135.2	44.0	60.0	24GSP42FDLORX45

DIN 24° FDLORX90

Female DIN 'O' ring swivel. 24° cone.
Light series. 90° swept elbow.

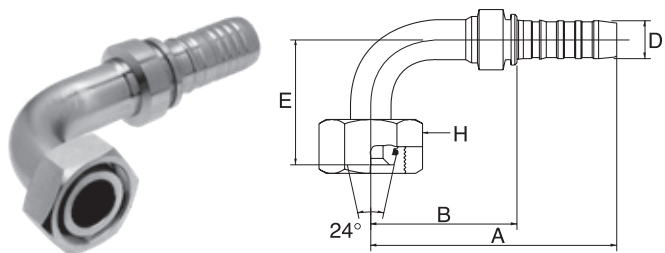

D			M52 x 2.0	A	B	E	H	REF.
-size	DN	"						
-24	40	1.1/2	M52 x 2.0	194.6	120.9	92.0	60.0	24GSP42FDLORX90

Unless otherwise stated the coupling meets the pressure rating requirements of the respective international standard.

COUPLINGS FOR WIRE AND TEXTILE BRAIDED HOSES GLOBALSPIRAL PLUS

THE WORLD OF COUPLINGS

DIN 24° MDL

Male DIN parallel. 24° inverted cone.
Light series.

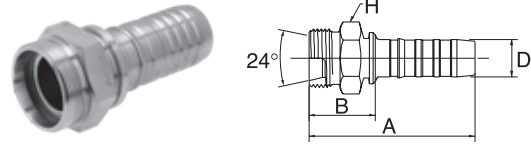

↻			🌀	↔	🔌		
D				A	B	H	REF.
-size	DN	"		mm	mm	mm	GSP
-24	40	1.1/2	M52 x 2.0	120.0	46.4	55.0	24GSP42MDL

DIN 24° FDHORX

Female DIN 'O' ring swivel. 24° cone.
Heavy series.

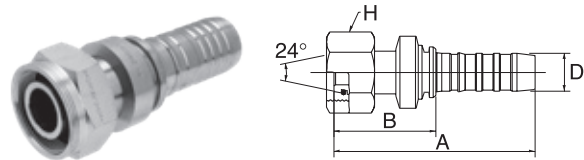

↻			🌀	↔	🔌		
D				A	B	H	REF.
-size	DN	"		mm	mm	mm	GSP
-24	40	1.1/2	M52 x 2.0	150.0	76.4	60.0	24GSP38FDHORX

DIN 24° FDHORX45

Female DIN 'O' ring swivel. 24° cone.
Heavy series. 45° swept elbow.

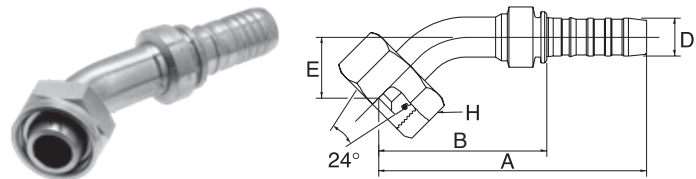

↻			🌀	↔	🔌			
D				A	B	E	H	REF.
-size	DN	"		mm	mm	mm	mm	GSP
-24	40	1.1/2	M52 x 2.0	208.9	135.2	44.0	60.0	24GSP38FDHORX45

Unless otherwise stated the coupling meets the pressure rating requirements of the respective international standard.

COUPLINGS FOR WIRE AND TEXTILE BRAIDED HOSES GLOBALSPIRAL PLUS

DIN 24° FDHORX90

Female DIN 'O' ring swivel. 24° cone.
Heavy series. 90° swept elbow.

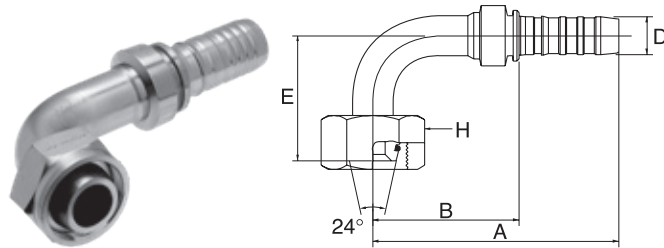

↻			🌀	↔	🌀			REF.
-size	DN	"		A	B	E	H	GSP
-24	40	1.1/2	M52 x 2.0	194.6	121.0	92.0	60.0	24GSP38FDHORX90

NPTF MP

Male NPTF pipe.

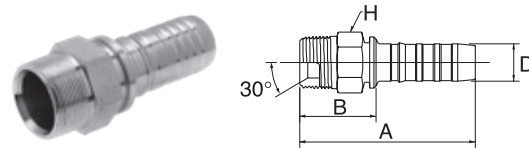

↻			🌀	↔	🌀			REF.
-size	DN	"		A	B	H	GSP	
-24	40	1.1/2	1.1/2" - 11.5 NPTF	133.0	59.4	50.8	24GSP24MP	
-32	50	2	2" - 11.5 NPTF	153.7	61.7	63.5	32GSP32MP	

Warning: Use only in NPTF connections. Do not use in oil field (API) connections. Blow apart of an oil field connection can result in serious injuries.

Unless otherwise stated the coupling meets the pressure rating requirements of the respective international standard.

COUPLINGS FOR WIRE AND TEXTILE BRAIDED HOSES MEGACRIMP®

THE WORLD OF COUPLINGS

BSP MBSPT

Male BSP taper.

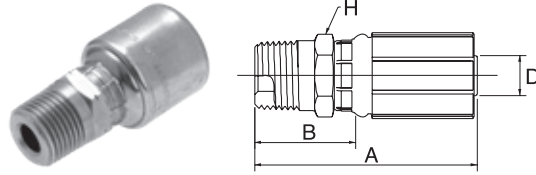

↔		🌀		↔			🌀
D				A	B	H	REF.
-size	DN	"		mm	mm	mm	G
-4	6	1/4	R 1/4" - 19 BSP	50.9	24.8	14.0	4G4MBSPT
-4	6	1/4	R 3/8" - 19 BSP	52.0	26.0	19.0	4G6MBSPT
-5	8	5/16	R 3/8" - 19 BSP	54.1	26.1	19.0	5G6MBSPT
-6	10	3/8	R 3/8" - 19 BSP	54.0	26.1	19.0	6G6MBSPT
-6	10	3/8	R 1/2" - 14 BSP	58.8	30.9	22.0	6G8MBSPT
-8	12	1/2	R 3/8" - 19 BSP	64.5	27.0	22.0	8G6MBSPT
-8	12	1/2	R 1/2" - 14 BSP	68.4	30.9	22.0	8G8MBSPT
-10	16	5/8	R 5/8" - 14 BSP	70.0	32.5	24.0	10G10MBSPT
-12	20	3/4	R 3/4" - 14 BSP	89.0	38.0	32.0	12G12MBSPT
-16	25	1	R 1" - 11 BSP	98.4	41.6	36.0	16G16MBSPT

Unless otherwise stated the coupling meets the pressure rating requirements of the respective international standard.

COUPLINGS FOR WIRE AND TEXTILE BRAIDED HOSES MEGACRIMP®

BSP FBSPORX

Female BSP 'O' ring swivel. 60° cone.

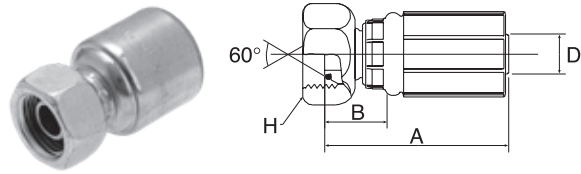

D				A	B	H	REF.
-size	DN	"		mm	mm	mm	G
-4	6	1/4	G 1/8" - 28 BSP	41.1	18.0	14.0	4G2FBSPX (1)
-4	6	1/4	G 1/4" - 19 BSP	43.0	17.0	19.0	4G4FBSPORX
-4	6	1/4	G 3/8" - 19 BSP	44.0	18.0	22.0	4G6FBSPORX
-5	8	5/16	G 3/8" - 19 BSP	46.0	18.0	22.0	5G6FBSPORX
-5	8	5/16	G 1/2" - 14 BSP	46.0	18.0	27.0	5G8FBSPORX
-6	10	3/8	G 3/8" - 19 BSP	44.1	16.2	22.0	6G6FBSPORX
-6	10	3/8	G 1/2" - 14 BSP	45.8	17.9	27.0	6G8FBSPORX
-8	12	1/2	G 3/8" - 19 BSP	59.2	21.7	22.0	8G6FBSPORX
-8	12	1/2	G 1/2" - 14 BSP	55.3	17.8	27.0	8G8FBSPORX
-8	12	1/2	G 5/8" - 14 BSP	57.2	19.7	30.0	8G10FBSPORX
-8	12	1/2	G 3/4" - 14 BSP	59.0	21.5	32.0	8G12FBSPORX
-10	16	5/8	G 5/8" - 14 BSP	56.0	18.5	30.0	10G10FBSPORX
-10	16	5/8	G 3/4" - 14 BSP	58.0	20.5	32.0	10G12FBSPORX
-12	20	3/4	G 3/4" - 14 BSP	71.6	20.6	32.0	12G12FBSPORX
-12	20	3/4	G 1" - 11 BSP	73.3	22.3	41.0	12G16FBSPORX
-16	25	1	G 3/4" - 14 BSP	82.7	25.9	32.0	16G12FBSPORX
-16	25	1	G 1" - 11 BSP	83.8	27.0	41.0	16G16FBSPORX
-20	32	1.1/4	G 1.1/4" - 11 BSP	88.5	29.5	50.0	20G20FBSPORX

(1) without 'O' ring.

Unless otherwise stated the coupling meets the pressure rating requirements of the respective international standard.

COUPLINGS FOR WIRE AND TEXTILE BRAIDED HOSES MEGACRIMP®

THE WORLD OF COUPLINGS

BSP FBSPORX45

Female BSP 'O' ring swivel. 60° cone.
45° swept elbow.

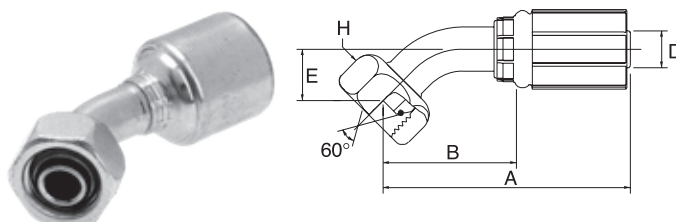

↻			🌀	↔				📐
D				A	B	E	H	REF.
-size	DN	"		mm	mm	mm	mm	G
-4	6	1/4	G 1/4" - 19 BSP	57.7	31.6	11.7	19.0	4G4FBSPORX45
-4	6	1/4	G 3/8" - 19 BSP	63.8	37.8	17.8	22.0	4G6FBSPORX45
-5	8	5/16	G 3/8" - 19 BSP	66.6	38.6	16.8	22.0	5G6FBSPORX45
-6	10	3/8	G 3/8" - 19 BSP	67.1	39.1	15.4	22.0	6G6FBSPORX45
-6	10	3/8	G 1/2" - 14 BSP	71.0	43.0	19.3	22.0	6G8FBSPORX45
-8	12	1/2	G 1/2" - 14 BSP	81.5	44.0	17.0	27.0	8G8FBSPORX45
-8	12	1/2	G 5/8" - 14 BSP	89.8	52.3	23.0	30.0	8G10FBSPORX45
-10	16	5/8	G 5/8" - 14 BSP	89.6	52.1	21.3	30.0	10G10FBSPORX45
-10	16	5/8	G 3/4" - 14 BSP	99.5	62.0	31.2	32.0	10G12FBSPORX45
-12	20	3/4	G 3/4" - 14 BSP	115.4	64.4	28.3	32.0	12G12FBSPORX45
-16	25	1	G 1" - 11 BSP	135.6	78.8	30.9	41.0	16G16FBSPORX45
-20	32	1.1/4	G 1.1/4" - 11 BSP	161.9	102.9	37.5	50.0	20G20FBSPORX45





Unless otherwise stated the coupling meets the pressure rating requirements of the respective international standard.

COUPLINGS FOR WIRE AND TEXTILE BRAIDED HOSES MEGACRIMP®

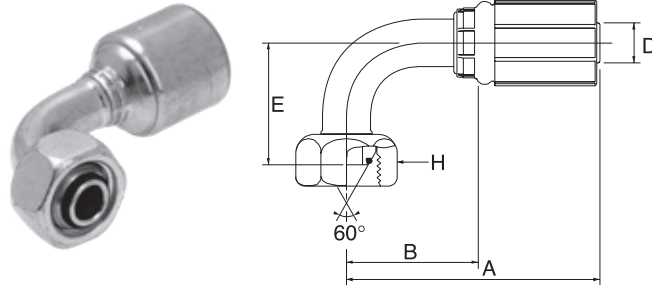
BSP FBSPORX90

Female BSP 'O' ring swivel. 60° cone.
90° swept elbow.



								
D				A	B	E	H	REF.
-size	DN	"		mm	mm	mm	mm	G
-4	6	1/4	G 1/4" - 19 BSP	53.0	27.0	23.5	19.0	4G4FBSPORX90
-4	6	1/4	G 3/8" - 19 BSP	53.0	27.0	32.0	22.0	4G6FBSPORX90
-5	8	5/16	G 3/8" - 19 BSP	58.0	30.0	32.0	22.0	5G6FBSPORX90
-6	10	3/8	G 3/8" - 19 BSP	61.9	34.0	32.0	22.0	6G6FBSPORX90
-6	10	3/8	G 1/2" - 14 BSP	60.1	32.2	37.5	22.0	6G8FBSPORX90
-8	12	1/2	G 1/2" - 14 BSP	78.0	40.5	37.5	27.0	8G8FBSPORX90
-8	12	1/2	G 5/8" - 14 BSP	80.2	42.8	46.0	30.0	8G10FBSPORX90
-10	16	5/8	G 5/8" - 14 BSP	84.1	46.6	46.0	30.0	10G10FBSPORX90
-10	16	5/8	G 3/4" - 14 BSP	84.1	46.6	60.0	32.0	10G12FBSPORX90
-12	20	3/4	G 3/4" - 14 BSP	107.0	56.0	60.0	32.0	12G12FBSPORX90
-12	20	3/4	G 1" - 11 BSP	112.2	61.2	70.0	41.0	12G16FBSPORX90
-16	25	1	G 3/4" - 14 BSP	108.8	52.0	54.1	32.0	16G12FBSPORX90
-16	25	1	G 1" - 11 BSP	131.1	74.3	70.0	41.0	16G16FBSPORX90
-20	32	1.1/4	G 1.1/4" - 11 BSP	151.4	92.4	80.0	50.0	20G20FBSPORX90

Unless otherwise stated the coupling meets the pressure rating requirements of the respective international standard.





COUPLINGS FOR WIRE AND TEXTILE BRAIDED HOSES MEGACRIMP®

THE WORLD OF COUPLINGS

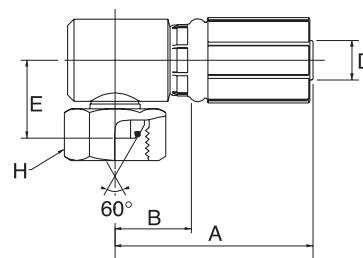
BSP FBSPORX90BL

Female BSP 'O' ring swivel. 60° cone.
90° block elbow.



								
D				A	B	E	H	REF.
-size	DN	"		mm	mm	mm	mm	G
-4	6	1/4	G 1/4" - 19 BSP	44.2	18.2	18.0	19.0	4G4FBSPORX90BL
-4	6	1/4	G 3/8" - 19 BSP	46.0	20.0	21.5	22.0	4G6FBSPORX90BL
-6	10	3/8	G 3/8" - 19 BSP	47.9	20.0	21.5	22.0	6G6FBSPORX90BL
-6	10	3/8	G 1/2" - 14 BSP	51.4	23.5	24.0	27.0	6G8FBSPORX90BL
-8	12	1/2	G 1/2" - 14 BSP	55.9	23.5	24.0	27.0	8G8FBSPORX90BL
-8	12	1/2	G 5/8" - 14 BSP	55.9	23.5	25.2	30.0	8G10FBSPORX90BL
-10	16	5/8	G 5/8" - 14 BSP	62.4	24.9	27.6	30.0	10G10FBSPORX90BL
-12	20	3/4	G 3/4" - 14 BSP	78.0	27.0	34.5	32.0	12G12FBSPORX90BL
-16	25	1	G 3/4" - 14 BSP	86.2	29.4	37.8	32.0	16G12FBSPORX90BL
-16	25	1	G 1" - 11 BSP	80.5	34.6	36.1	41.0	16G16FBSPORX90BL

Unless otherwise stated the coupling meets the pressure rating requirements of the respective international standard.

COUPLINGS FOR WIRE AND TEXTILE BRAIDED HOSES MEGACRIMP®

BSP MBSPP

Male BSP parallel. 60° inverted cone.

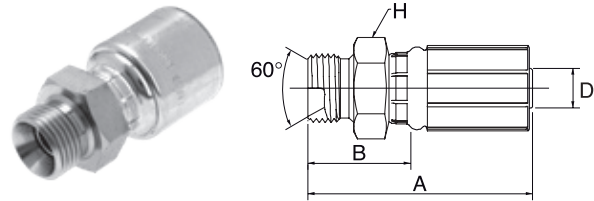

↔			🌀	↔	↔			🌀
D				A	B	H	REF.	
-size	DN	"		mm	mm	mm	G	
-4	6	1/4	G 1/4" - 19 BSP	51.5	25.5	19.0	4G4MBSPP	
-4	6	1/4	G 3/8" - 19 BSP	48.9	25.8	22.0	4G6MBSPP	
-4	6	1/4	G 1/2" - 14 BSP	56.6	33.5	27.0	4G8MBSPP	
-5	8	5/16	G 1/4" - 19 BSP	49.4	25.5	19.0	5G4MBSPP	
-5	8	5/16	G 3/8" - 19 BSP	49.7	25.8	22.0	5G6MBSPP	
-6	10	3/8	G 1/4" - 19 BSP	52.0	24.1	19.0	6G4MBSPP	
-6	10	3/8	G 3/8" - 19 BSP	55.0	27.1	22.0	6G6MBSPP	
-6	10	3/8	G 1/2" - 14 BSP	60.0	32.1	27.0	6G8MBSPP	
-8	12	1/2	G 3/8" - 19 BSP	58.5	26.0	22.0	8G6MBSPP	
-8	12	1/2	G 1/2" - 14 BSP	69.0	31.5	27.0	8G8MBSPP	
-8	12	1/2	G 5/8" - 14 BSP	71.0	33.5	30.0	8G10MBSPP	
-10	16	5/8	G 5/8" - 14 BSP	72.0	34.5	30.0	10G10MBSPP	
-10	16	5/8	G 3/4" - 14 BSP	74.0	36.5	32.0	10G12MBSPP	
-12	20	3/4	G 3/4" - 14 BSP	90.0	39.0	32.0	12G12MBSPP	
-16	25	1	G 1" - 11 BSP	101.0	44.2	41.0	16G16MBSPP	
-20	32	1.1/4	G 1" - 11 BSP	104.5	45.5	46.0	20G16MBSPP	
-20	32	1.1/4	G 1.1/4" - 11 BSP	110.0	51.0	50.0	20G20MBSPP	

BSP MBSPPBKHD

Male BSP parallel.
60° inverted cone [Bulkhead].

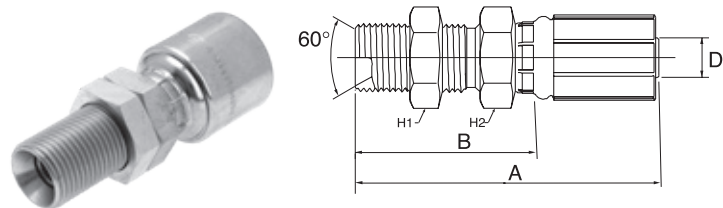

↔			🌀	↔	↔			🌀
D				A	B	H1	H2	REF.
-size	DN	"		mm	mm	mm	mm	G
-4	6	1/4	G 1/4" - 19 BSP	69.0	43.0	19.0	19.0	4G4MBSPPBKHD
-6	10	3/8	G 3/8" - 19 BSP	75.0	47.1	22.0	22.0	6G6MBSPPBKHD
-8	12	1/2	G 1/2" - 14 BSP	88.5	51.0	27.0	27.0	8G8MBSPPBKHD
-10	16	5/8	G 5/8" - 14 BSP	93.0	55.5	30.0	30.0	10G10MBSPPBKHD
-12	20	3/4	G 3/4" - 14 BSP	109.0	58.0	32.0	32.0	12G12MBSPPBKHD
-16	25	1	G 1" - 11 BSP	121.2	64.4	41.0	41.0	16G16MBSPPBKHD

Unless otherwise stated the coupling meets the pressure rating requirements of the respective international standard.

COUPLINGS FOR WIRE AND TEXTILE BRAIDED HOSES MEGACRIMP®

THE WORLD OF COUPLINGS

BSP FBFFX

Female BSP flat face swivel.

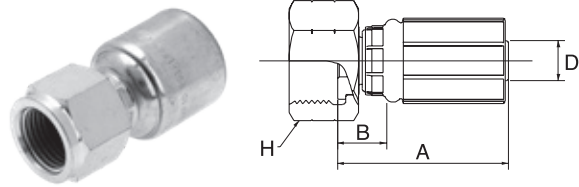

↔			🌀	↔	↔		🌀
D				A	B	H	REF.
-size	DN	"		mm	mm	mm	G
-5	8	5/16	G 1/2" - 14 BSP	45.5	17.5	27.0	5G8FBFFX
-6	10	3/8	G 3/8" - 19 BSP	44.5	16.6	22.0	6G6FBFFX
-6	10	3/8	G 1/2" - 14 BSP	44.0	16.1	27.0	6G8FBFFX
-8	12	1/2	G 1/2" - 14 BSP	53.5	16.0	27.0	8G8FBFFX
-8	12	1/2	G 5/8" - 14 BSP	54.0	16.5	30.0	8G10FBFFX
-8	12	1/2	G 3/4" - 14 BSP	51.5	14.0	32.0	8G12FBFFX
-10	16	5/8	G 3/4" - 14 BSP	52.0	14.5	32.0	10G12FBFFX
-12	20	3/4	G 3/4" - 14 BSP	65.5	14.5	32.0	12G12FBFFX

BSP BSPBJ

BSP banjo.

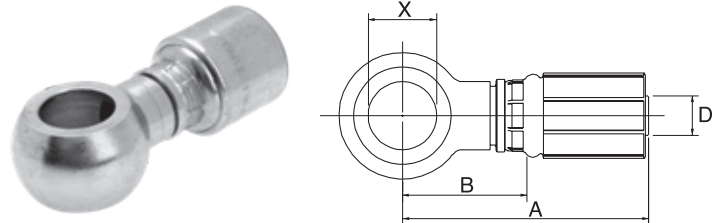

↔			🌀	↔	↔		🌀
D				A	B	X	REF.
-size	DN	"		mm	mm	mm	G
-4	6	1/4	1/4" - BSP	56.0	30.0	13.2	4G4BSPBJ
-4	6	1/4	3/8" - BSP	58.3	32.3	16.8	4G6BSPBJ
-6	10	3/8	1/4" - BSP	58.5	30.6	13.2	6G4BSPBJ
-6	10	3/8	3/8" - BSP	60.0	32.1	16.9	6G6BSPBJ
-6	10	3/8	1/2" - BSP	62.7	34.8	21.0	6G8BSPBJ
-8	12	1/2	1/2" - BSP	75.7	38.2	21.0	8G8BSPBJ
-12	20	3/4	3/4" - BSP	94.7	43.7	26.5	12G12BSPBJ

-4 to -12 size are 10.0 MPa (1450 psi).

Unless otherwise stated the coupling meets the pressure rating requirements of the respective international standard.

COUPLINGS FOR WIRE AND TEXTILE BRAIDED HOSES MEGACRIMP®

JIC 37° FJX

Female JIC swivel. 37° inverted cone.

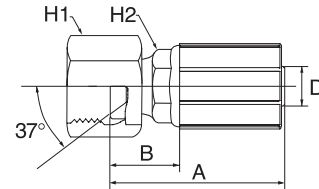

D				A	B	H1	H2	REF.
-size	DN	"		mm	mm	mm	mm	G
-4	6	1/4	7/16" - 20 UNF	49.0	23.0	14.0	15.0	4G4FJX
-4	6	1/4	1/2" - 20 UNF	50.0	24.0	15.0	17.0	4G5FJX
-4	6	1/4	9/16" - 18 UNF	51.2	25.2	19.0	15.0	4G6FJX
-5	8	5/16	1/2" - 20 UNF	55.1	28.6	17.0	17.0	5G5FJX
-5	8	5/16	9/16" - 18 UNF	55.1	28.6	19.0	17.0	5G6FJX
-6	10	3/8	7/16" - 20 UNF	74.7	46.8	14.0	15.9	6G4FJX
-6	10	3/8	1/2" - 20 UNF	75.2	47.3	17.0	17.0	6G5FJX
-6	10	3/8	9/16" - 18 UNF	53.0	24.2	19.0	18.0	6G6FJX
-6	10	3/8	3/4" - 16 UNF	56.3	27.5	24.0	18.0	6G8FJX
-6	10	3/8	7/8" - 14 UNF	56.4	27.6	27.0	18.0	6G10FJX
-8	12	1/2	9/16" - 18 UNF	88.1	50.6	19.0	22.0	8G6FJX
-8	12	1/2	3/4" - 16 UNF	62.8	27.3	24.0	22.0	8G8FJX
-8	12	1/2	7/8" - 14 UNF	62.8	27.3	27.0	22.0	8G10FJX
-8	12	1/2	1.1/16" - 12 UN	62.8	27.3	32.0	22.0	8G12FJX
-10	16	5/8	3/4" - 16 UNF	92.6	55.1	24.0	24.0	10G8FJX
-10	16	5/8	7/8" - 14 UNF	66.0	28.5	27.0	24.0	10G10FJX
-10	16	5/8	1.1/16" - 12 UN	66.4	28.9	31.8	24.0	10G12FJX
-10	16	5/8	1.3/16" - 12 UN	70.0	32.5	36.0	24.0	10G14FJX
-12	20	3/4	7/8" - 14 UNF	122.0	71.0	27.0	27.0	12G10FJX
-12	20	3/4	1.1/16" - 12 UN	80.0	29.0	32.0	30.0	12G12FJX
-12	20	3/4	1.3/16" - 12 UN	80.8	29.8	36.0	30.0	12G14FJX
-12	20	3/4	1.5/16" - 12 UN	81.1	30.1	41.0	30.0	12G16FJX
-16	25	1	1.1/16" - 12 UN	135.9	79.2	32.0	36.0	16G12FJX
-16	25	1	1.3/16" - 12 UN	146.0	89.2	36.0	36.0	16G14FJX
-16	25	1	1.5/16" - 12 UN	91.0	34.2	41.0	36.0	16G16FJX
-16	25	1	1.5/8" - 12 UN	99.0	42.2	50.0	36.0	16G20FJX
-20	32	1.1/4	1.5/8" - 12 UN	96.0	37.0	50.0	41.0	20G20FJX
-20	32	1.1/4	1.7/8" - 12 UN	104.0	45.0	60.0	41.0	20G24FJX

Unless otherwise stated the coupling meets the pressure rating requirements of the respective international standard.

COUPLINGS FOR WIRE AND TEXTILE BRAIDED HOSES MEGACRIMP®

THE WORLD OF COUPLINGS

JIC 37° FJX45

Female JIC swivel. 37° inverted cone.
45° swept elbow.

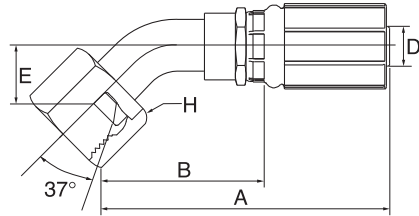

↻			🌀	↔	🔧			REF.
D				A	B	E	H	REF.
-size	DN	"		mm	mm	mm	mm	G
-4	6	1/4	7/16" - 20 UNF	69.7	43.7	10.0	14.0	4G4FJX45S
-4	6	1/4	1/2" - 20 UNF	65.8	39.7	11.0	17.0	4G5FJX45-011
-4	6	1/4	9/16" - 18 UNF	68.3	42.3	11.0	19.0	4G6FJX45S
-5	8	5/16	1/2" - 20 UNF	68.3	40.3	11.0	17.0	5G5FJX45-011
-5	8	5/16	9/16" - 18 UNF	72.4	44.4	11.0	19.0	5G6FJX45S
-6	10	3/8	7/16" - 20 UNF	72.7	44.8	10.0	14.0	6G4FJX45S
-6	10	3/8	9/16" - 18 UNF	77.5	49.6	11.0	19.0	6G6FJX45S
-6	10	3/8	3/4" - 16 UNF	89.1	61.2	15.0	24.0	6G8FJX45S
-8	12	1/2	3/4" - 16 UNF	86.9	49.5	15.0	24.0	8G8FJX45S
-8	12	1/2	7/8" - 14 UNF	96.8	59.4	16.0	27.0	8G10FJX45S
-10	16	5/8	7/8" - 14 UNF	96.4	59.0	16.0	27.0	10G10FJX45S
-10	16	5/8	1.1/16" - 12 UN	115.7	78.2	21.0	32.0	10G12FJX45S
-12	20	3/4	7/8" - 14 UNF	116.3	65.3	19.0	27.0	12G10FJX45S
-12	20	3/4	1.1/16" - 12 UN	128.2	77.2	21.0	32.0	12G12FJX45S
-12	20	3/4	1.5/16" - 12 UN	133.1	82.1	24.0	41.0	12G16FJX45S
-16	25	1	1.5/16" - 12 UN	144.3	87.5	24.0	41.0	16G16FJX45S
-20	32	1.1/4	1.5/8" - 12 UN	169.0	110.0	35.0	50.0	20G20FJX45-035

S: Short drop per ISO 12151-5.

Unless otherwise stated the coupling meets the pressure rating requirements of the respective international standard.

COUPLINGS FOR WIRE AND TEXTILE BRAIDED HOSES MEGACRIMP®

JIC 37° FJX90S

Female JIC swivel. 37° inverted cone.
90° swept elbow. Short drop.

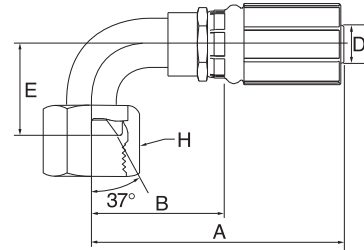

↻			🌀	↔				📏
D				A	B	E	H	REF.
-size	DN	"		mm	mm	mm	mm	G
-4	6	1/4	7/16" - 20 UNF	63.1	37.1	21.0	14.0	4G4FJX90S
-4	6	1/4	1/2" - 20 UNF	62.2	36.2	23.0	17.0	4G5FJX90-023
-4	6	1/4	9/16" - 18 UNF	71.2	45.1	23.0	19.0	4G6FJX90S
-5	8	5/16	9/16" - 18 UNF	75.2	47.2	23.0	19.0	5G6FJX90S
-6	10	3/8	7/16" - 20 UNF	66.1	38.2	21.0	14.0	6G4FJX90S
-6	10	3/8	9/16" - 18 UNF	78.6	50.7	23.0	19.0	6G6FJX90S
-6	10	3/8	3/4" - 16 UNF	80.7	52.8	29.0	24.0	6G8FJX90S
-8	12	1/2	9/16" - 18 UNF	89.6	52.1	23.0	19.0	8G6FJX90S
-8	12	1/2	3/4" - 16 UNF	81.0	43.6	29.0	24.0	8G8FJX90S
-8	12	1/2	7/8" - 14 UNF	93.3	55.8	32.0	27.0	8G10FJX90S
-8	12	1/2	1.1/16" - 12 UN	108.7	71.2	48.0	32.0	8G12FJX90S
-10	16	5/8	7/8" - 14 UNF	89.0	51.5	36.0	27.0	10G10FJX90-036
-10	16	5/8	1.1/16" - 12 UN	107.3	69.8	48.0	32.0	10G12FJX90S
-12	20	3/4	1.1/16" - 12 UN	121.2	70.2	48.0	32.0	12G12FJX90S
-12	20	3/4	1.3/16" - 12 UN	124.0	73.0	54.0	36.0	12G14FJX90-054
-12	20	3/4	1.5/16" - 12 UN	132.7	81.7	56.0	41.0	12G16FJX90S
-16	25	1	1.5/16" - 12 UN	145.6	88.8	56.0	41.0	16G16FJX90S
-16	25	1	1.5/8" - 12 UN	157.0	100.2	64.0	50.0	16G20FJX90S

S: Short drop per ISO 12151-5.

Unless otherwise stated the coupling meets the pressure rating requirements of the respective international standard.

COUPLINGS FOR WIRE AND TEXTILE BRAIDED HOSES MEGACRIMP®

THE WORLD OF COUPLINGS

JIC 37° FJX90M

Female JIC swivel. 37° inverted cone.
90° swept elbow. Medium drop.

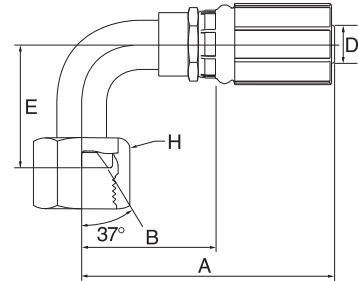

↻			🌀	↔				🔌
D				A	B	E	H	REF.
-size	DN	"		mm	mm	mm	mm	G
-4	6	1/4	7/16" - 20 UNF	63.1	37.1	32.0	14.0	4G4FJX90M
-4	6	1/4	1/2" - 20 UNF	57.2	31.2	32.0	17.0	4G5FJX90M
-4	6	1/4	9/16" - 18 UNF	64.9	38.9	38.0	19.0	4G6FJX90M
-5	8	5/16	1/2" - 20 UNF	64.6	36.6	32.0	17.0	5G5FJX90M
-5	8	5/16	9/16" - 18 UNF	76.0	48.0	38.0	19.0	5G6FJX90M
-6	10	3/8	9/16" - 18 UNF	76.5	48.5	38.0	19.0	6G6FJX90M
-6	10	3/8	3/4" - 16 UNF	84.1	56.2	41.0	24.0	6G8FJX90M
-6	10	3/8	7/8" - 14 UNF	82.5	54.6	47.0	27.0	6G10FJX90M
-8	12	1/2	3/4" - 16 UNF	77.3	39.9	41.0	24.0	8G8FJX90M
-8	12	1/2	7/8" - 14 UNF	93.3	55.8	47.0	27.0	8G10FJX90M
-10	16	5/8	7/8" - 14 UNF	93.4	55.9	47.0	27.0	10G10FJX90M
-10	16	5/8	1.1/16" - 12 UN	102.3	64.8	58.0	32.0	10G12FJX90M
-12	20	3/4	7/8" - 14 UNF	114.1	63.1	47.0	27.0	12G10FJX90M
-12	20	3/4	1.1/16" - 12 UN	120.2	69.2	58.0	32.0	12G12FJX90M
-16	25	1	1.5/16" - 12 UN	120.2	63.4	71.0	41.0	16G16FJX90M
-20	32	1.1/4	1.5/8" - 12 UN	159.0	100.0	78.0	50.0	20G20FJX90M

M: Medium drop per ISO 12151-5.

Unless otherwise stated the coupling meets the pressure rating requirements of the respective international standard.

COUPLINGS FOR WIRE AND TEXTILE BRAIDED HOSES MEGACRIMP®

JIC 37° FJX90L

Female JIC swivel. 37° inverted cone.
90° swept elbow. Long drop.

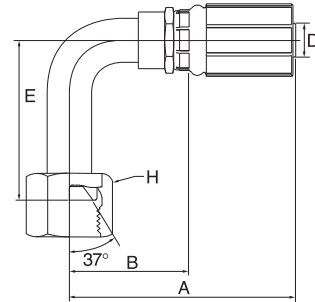

D				A	B	E	H	REF.
-size	DN	"		mm	mm	mm	mm	G
-4	6	1/4	7/16" - 20 UNF	63.1	37.1	46.0	14.0	4G4FJX90L
-4	6	1/4	1/2" - 20 UNF	57.2	31.2	46.0	17.0	4G5FJX90L
-4	6	1/4	9/16" - 18 UNF	69.3	43.2	54.0	19.0	4G6FJX90L
-6	10	3/8	7/16" - 20 UNF	60.2	32.3	46.0	14.0	6G4FJX90L
-6	10	3/8	9/16" - 18 UNF	70.6	42.7	54.0	19.0	6G6FJX90L
-6	10	3/8	3/4" - 16 UNF	84.5	56.6	64.0	24.0	6G8FJX90L
-8	12	1/2	3/4" - 16 UNF	77.3	39.9	64.0	24.0	8G8FJX90L
-8	12	1/2	7/8" - 14 UNF	93.3	55.8	70.0	27.0	8G10FJX90L
-10	16	5/8	7/8" - 14 UNF	85.9	48.4	70.0	27.0	10G10FJX90L
-10	16	5/8	1.1/16" - 12 UN	115.7	78.2	96.0	32.0	10G12FJX90L
-12	20	3/4	1.1/16" - 12 UN	122.2	71.2	96.0	32.0	12G12FJX90L
-12	20	3/4	1.3/16" - 12 UN	107.4	56.4	100.0	36.0	12G14FJX90-100
-16	25	1	1.5/16" - 12 UN	120.3	63.5	114.0	41.0	16G16FJX90L
-20	32	1.1/4	1.5/8" - 12 UN	158.0	99.0	129.0	50.0	20G20FJX90L

L: Long drop per ISO 12151-5.

Unless otherwise stated the coupling meets the pressure rating requirements of the respective international standard.

COUPLINGS FOR WIRE AND TEXTILE BRAIDED HOSES MEGACRIMP®

THE WORLD OF COUPLINGS

JIC 37° MJ

Male JIC parallel. 37° cone.

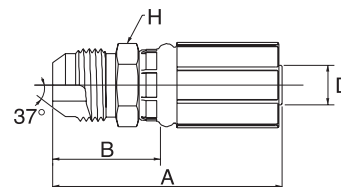

↔			🌀	↔	↔			🌀
D				A	B	H	REF.	
-size	DN	"		mm	mm	mm	G	
-4	6	1/4	7/16" - 20 UNF	55.5	29.5	14.0	4G4MJ	
-4	6	1/4	1/2" - 20 UNF	55.5	29.5	14.0	4G5MJ	
-4	6	1/4	9/16" - 18 UNF	56.5	30.5	17.0	4G6MJ	
-5	8	5/16	1/2" - 20 UNF	57.5	29.5	17.0	5G5MJ	
-5	8	5/16	9/16" - 18 UNF	57.5	29.5	17.0	5G6MJ	
-6	10	3/8	9/16" - 18 UNF	58.5	30.6	17.0	6G6MJ	
-6	10	3/8	3/4" - 16 UNF	63.0	35.1	19.0	6G8MJ	
-6	10	3/8	7/8" - 14 UNF	67.0	39.1	24.0	6G10MJ	
-8	12	1/2	3/4" - 16 UNF	71.5	34.0	22.0	8G8MJ	
-8	12	1/2	7/8" - 14 UNF	74.0	36.5	24.0	8G10MJ	
-8	12	1/2	1.1/16" - 12 UN	81.0	43.5	27.0	8G12MJ	
-10	16	5/8	3/4" - 16 UNF	74.5	37.0	24.0	10G8MJ	
-10	16	5/8	7/8" - 14 UNF	77.0	39.5	24.0	10G10MJ	
-10	16	5/8	1.1/16" - 12 UN	81.0	43.5	27.0	10G12MJ	
-12	20	3/4	1.1/16" - 12 UN	94.5	43.5	27.0	12G12MJ	
-12	20	3/4	1.3/16" - 12 UN	95.5	44.5	32.0	12G14MJ	
-12	20	3/4	1.5/16" - 12 UN	96.0	45.0	36.0	12G16MJ	
-16	25	1	1.5/16" - 12 UN	104.5	47.7	36.0	16G16MJ	
-16	25	1	1.5/8" - 12 UN	109.0	52.2	44.5	16G20MJ	
-20	32	1.1/4	1.5/8" - 12 UN	112.5	53.5	46.0	20G20MJ	

Unless otherwise stated the coupling meets the pressure rating requirements of the respective international standard.

COUPLINGS FOR WIRE AND TEXTILE BRAIDED HOSES MEGACRIMP®

JIS FJISX

Female Japanese swivel.
30° inverted cone. BSP thread.

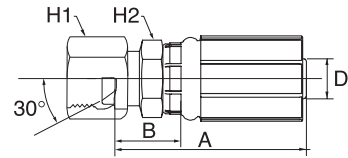

↔			🌀	↔	↔			🌀
D				A	B	H1	H2	REF.
-size	DN	"		mm	mm	mm	mm	G
-4	6	1/4	G 1/2" - 14 BSP	50.0	24.0	19.0	15.0	4G4FJISX
-6	10	3/8	G 3/8" - 19 BSP	52.0	24.1	22.0	17.0	6G6FJISX
-8	12	1/2	G 1/2" - 14 BSP	67.9	30.4	27.0	22.0	8G8FJISX
-12	20	3/4	G 3/4" - 14 BSP	81.3	30.3	36.0	30.0	12G12FJISX
-16	25	1	G 1" - 11 BSP	94.0	37.2	41.0	41.0	16G16FJISX

JIS FKX

Female Japanese swivel.
30° inverted cone. Metric thread.

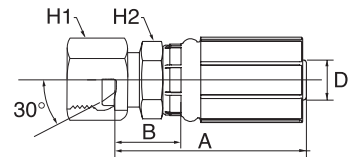

↔			🌀	↔	↔			🌀
D				A	B	H1	H2	REF.
-size	DN	"		mm	mm	mm	mm	G
-4	6	1/4	M14 x 1.5	46.5	20.5	19.0	14.0	4G4FKX
-6	10	3/8	M18 x 1.5	52.0	24.1	22.2	17.5	6G6FKX
-8	12	1/2	M22 x 1.5	61.5	24.0	27.0	22.0	8G8FKX
-10	16	5/8	M24 x 1.5	63.5	26.0	32.0	24.0	10G10FKX
-12	20	3/4	M30 x 1.5	82.3	31.3	36.0	30.0	12G12FKX
-16	25	1	M33 x 1.5	92.5	35.7	41.0	41.0	16G16FKX
-20	32	1.1/4	M36 x 1.5	105.0	46.0	50.8	44.5	20G20FKX

Unless otherwise stated the coupling meets the pressure rating requirements of the respective international standard.

COUPLINGS FOR WIRE AND TEXTILE BRAIDED HOSES MEGACRIMP®

THE WORLD OF COUPLINGS

SAE FFORX

Female SAE flat face 'O' ring swivel.

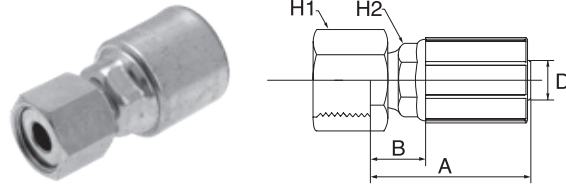

↔			🌀	↔				🌀
D				A	B	H1	H2	REF.
-size	DN	"		mm	mm	mm	mm	G
-4	6	1/4	9/16" - 18 UNF	52.5	26.5	17.0	15.0	4G4FFORX
-4	6	1/4	11/16" - 16 UN	51.1	25.1	22.0	15.0	4G6FFORX
-4	6	1/4	13/16" - 16 UN	50.5	24.5	24.0	15.0	4G8FFORX
-5	8	5/16	11/16" - 16 UN	61.5	33.5	22.0	17.0	5G6FFORX
-6	10	3/8	9/16" - 18 UNF	78.3	50.3	17.0	17.0	6G4FFORX
-6	10	3/8	11/16" - 16 UN	57.7	28.9	22.0	18.0	6G6FFORX
-6	10	3/8	13/16" - 16 UN	57.4	28.6	24.0	18.0	6G8FFORX
-6	10	3/8	1" - 14 UNS	56.0	27.2	30.0	18.0	6G10FFORX
-8	12	1/2	11/16" - 16 UN	95.9	58.4	22.0	22.0	8G6FFORX
-8	12	1/2	13/16" - 16 UN	66.5	31.0	24.0	22.0	8G8FFORX
-8	12	1/2	1" - 14 UNS	70.0	34.8	30.0	22.0	8G10FFORX
-8	12	1/2	1.3/16" - 12 UN	71.5	36.3	36.0	22.0	8G12FFORX
-10	12	5/8	13/16" - 16 UN	97.2	59.7	24.0	24.0	10G8FFORX
-10	16	5/8	1" - 14 UNS	76.0	38.5	30.0	24.0	10G10FFORX
-10	16	5/8	1.3/16" - 12 UN	77.0	39.5	36.0	24.0	10G12FFORX
-12	20	3/4	1" - 14 UNS	95.1	44.1	30.0	30.0	12G10FFORX
-12	20	3/4	1.3/16" - 12 UN	92.8	41.8	36.0	30.0	12G12FFORX
-12	20	3/4	1.7/16" - 12 UN	88.3	37.3	41.0	30.0	12G16FFORX
-16	25	1	1.7/16" - 12 UN	104.0	47.2	41.0	36.0	16G16FFORX
-16	25	1	1.11/16" - 12 UN	103.0	46.2	50.0	36.0	16G20FFORX
-20	32	1.1/4	1.11/16" - 12 UN	109.0	50.0	50.0	41.0	20G20FFORX

Unless otherwise stated the coupling meets the pressure rating requirements of the respective international standard.

COUPLINGS FOR WIRE AND TEXTILE BRAIDED HOSES MEGACRIMP®

SAE FFORX45

Female SAE flat face 'O' ring swivel.
45° swept elbow.

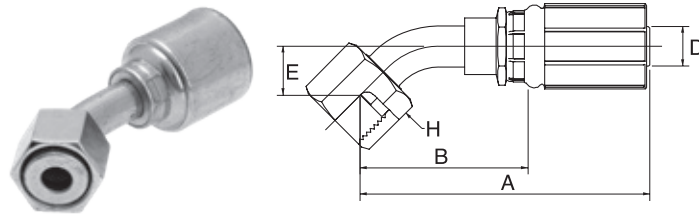

↻			🌀	↔	🌀			REF.
-size	D DN	"		A mm	B mm	E mm	H mm	G
-4	6	1/4	9/16" - 18 UNF	65.2	39.2	10.0	17.0	4G4FFORX45S
-4	6	1/4	11/16" - 16 UN	68.5	42.5	11.0	22.0	4G6FFORX45S
-5	8	5/16	11/16" - 16 UN	69.4	41.4	11.0	22.0	5G6FFORX45S
-6	10	3/8	9/16" - 18 UNF	66.1	38.1	10.0	17.0	6G4FFORX45S
-6	10	3/8	11/16" - 16 UN	69.8	41.9	11.0	22.0	6G6FFORX45S
-6	10	3/8	13/16" - 16 UN	85.2	57.3	15.0	24.0	6G8FFORX45S
-8	12	1/2	11/16" - 16 UN	90.7	53.2	11.0	22.0	8G6FFORX45S
-8	12	1/2	13/16" - 16 UN	89.0	51.6	15.0	24.0	8G8FFORX45S
-8	12	1/2	1" - 14 UNS	101.0	63.5	16.0	30.0	8G10FFORX45S
-8	12	1/2	1.3/16" - 12 UN	110.3	72.8	21.0	36.0	8G12FFORX45S
-10	16	5/8	13/16" - 16 UN	96.8	59.3	15.0	24.0	10G8FFORX45S
-10	16	5/8	1" - 14 UNS	100.5	63.0	16.0	30.0	10G10FFORX45S
-10	16	5/8	1.3/16" - 12 UN	105.9	68.4	21.0	36.0	10G12FFORX45S
-12	20	3/4	1" - 14 UNS	113.0	62.0	16.0	30.0	12G10FFORX45S
-12	20	3/4	1.3/16" - 12 UN	118.4	67.4	21.0	36.0	12G12FFORX45S
-12	20	3/4	1.7/16" - 12 UN	122.0	71.0	24.0	41.0	12G16FFORX45S
-16	25	1	1.3/16" - 12 UN	132.5	75.7	21.0	36.0	16G12FFORX45S
-16	25	1	1.7/16" - 12 UN	146.9	90.1	24.0	41.0	16G16FFORX45S
-20	32	1.1/4	1.11/16" - 12 UN	158.0	99.0	25.0	50.0	20G20FFORX45S

S: Short drop per ISO 12151-1.

Unless otherwise stated the coupling meets the pressure rating requirements of the respective international standard.

COUPLINGS FOR WIRE AND TEXTILE BRAIDED HOSES MEGACRIMP®

THE WORLD OF COUPLINGS

SAE FFORX90S

Female SAE flat face 'O' ring swivel.
90° swept elbow. Short drop.

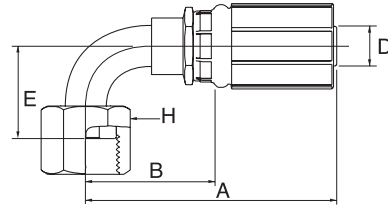

D				A B E H				REF.
-size	DN	"		mm	mm	mm	mm	G
-4	6	1/4	9/16" - 18 UNF	60.2	34.2	21.0	17.0	4G4FFORX90S
-4	6	1/4	11/16" - 16 UN	63.4	37.4	23.0	22.0	4G6FFORX90S
-5	8	5/16	11/16" - 16 UN	72.0	44.0	23.0	22.0	5G6FFORX90S
-6	10	3/8	9/16" - 18 UNF	61.4	33.6	21.0	17.0	6G4FFORX90S
-6	10	3/8	11/16" - 16 UN	72.5	44.6	23.0	22.0	6G6FFORX90S
-6	10	3/8	13/16" - 16 UN	73.0	45.1	29.0	24.0	6G8FFORX90S
-8	12	1/2	11/16" - 16 UN	83.5	46.0	23.0	22.0	8G6FFORX90S
-8	12	1/2	13/16" - 16 UN	83.9	46.5	29.0	24.0	8G8FFORX90S
-8	12	1/2	1" - 14 UNS	92.9	55.4	32.0	30.0	8G10FFORX90S
-8	12	1/2	1.3/16" - 12 UN	102.9	65.4	48.0	36.0	8G12FFORX90S
-10	16	5/8	13/16" - 16 UN	92.4	54.9	29.0	24.0	10G8FFORX90S
-10	16	5/8	1" - 14 UNS	92.5	55.0	32.0	30.0	10G10FFORX90S
-10	16	5/8	1.3/16" - 12 UN	96.3	58.8	48.0	36.0	10G12FFORX90S
-12	20	3/4	1" - 14 UNS	104.0	53.0	32.0	30.0	12G10FFORX90S
-12	20	3/4	1.3/16" - 12 UN	108.8	57.8	48.0	36.0	12G12FFORX90S
-12	20	3/4	1.7/16" - 12 UN	128.5	77.5	56.0	41.0	12G16FFORX90S
-16	25	1	1.3/16" - 12 UN	129.4	72.6	48.0	36.0	16G12FFORX90S
-16	25	1	1.7/16" - 12 UN	129.9	73.1	56.0	41.0	16G16FFORX90S
-20	32	1.1/4	1.11/16" - 12 UN	150.0	91.0	64.0	50.0	20G20FFORX90S

S: Short drop per ISO 12151-1.





Unless otherwise stated the coupling meets the pressure rating requirements of the respective international standard.

COUPLINGS FOR WIRE AND TEXTILE BRAIDED HOSES MEGACRIMP®

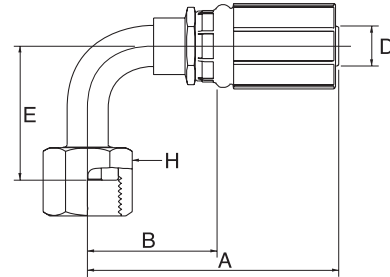
SAE FFORX90M

Female SAE flat face 'O' ring swivel.
90° swept elbow. Medium drop.



								
D				A	B	E	H	REF.
-size	DN	"		mm	mm	mm	mm	G
-4	6	1/4	9/16" - 18 UNF	56.2	30.2	32.0	17.0	4G4FFORX90M
-4	6	1/4	11/16" - 16 UN	63.4	37.4	38.0	22.0	4G6FFORX90M
-6	10	3/8	11/16" - 16 UN	63.6	35.7	38.0	22.0	6G6FFORX90M
-6	10	3/8	13/16" - 16 UN	68.5	40.6	41.0	24.0	6G8FFORX90M
-8	12	1/2	13/16" - 16 UN	83.9	46.5	41.0	24.0	8G8FFORX90M
-8	12	1/2	1" - 14 UNS	93.2	55.7	47.0	30.0	8G10FFORX90M
-10	16	5/8	1" - 14 UNS	92.8	55.3	47.0	30.0	10G10FFORX90M
-12	20	3/4	1.3/16" - 12 UN	109.0	58.0	58.0	36.0	12G12FFORX90M
-16	25	1	1.7/16" - 12 UN	129.9	73.1	71.0	41.0	16G16FFORX90M
-16	25	1	1.11/16" - 12 UN	156.0	99.2	78.0	50.0	16G20FFORX90M
-20	32	1.1/4	1.11/16" - 12 UN	140.0	81.0	78.0	50.0	20G20FFORX90M

M: Medium drop per ISO 12151-1.

Unless otherwise stated the coupling meets the pressure rating requirements of the respective international standard.

COUPLINGS FOR WIRE AND TEXTILE BRAIDED HOSES MEGACRIMP®

THE WORLD OF COUPLINGS

SAE FFORX90L

Female SAE flat face 'O' ring swivel.
90° swept elbow. Long drop.

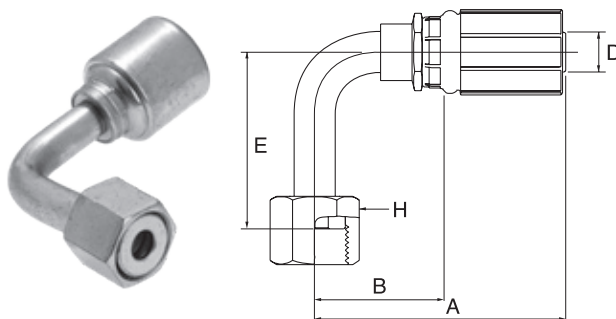

↻			🌀	↔	📏			🔍
D				A	B	E	H	REF.
-size	DN	"		mm	mm	mm	mm	G
-4	6	1/4	9/16" - 18 UNF	56.2	30.2	46.0	17.0	4G4FFORX90L
-4	6	1/4	11/16" - 16 UN	61.6	35.6	54.0	22.0	4G6FFORX90L
-4	6	1/4	13/16" - 16 UN	67.1	41.1	64.0	24.0	4G8FFORX90L
-6	10	3/8	11/16" - 16 UN	69.3	41.4	54.0	22.0	6G6FFORX90L
-6	10	3/8	13/16" - 16 UN	69.0	41.1	64.0	24.0	6G8FFORX90L
-8	12	1/2	13/16" - 16 UN	83.9	46.5	64.0	24.0	8G8FFORX90L
-8	12	1/2	1" - 14 UNS	90.6	53.1	70.0	30.0	8G10FFORX90L
-10	16	5/8	13/16" - 16 UN	92.4	54.9	64.0	24.0	10G8FFORX90L
-10	16	5/8	1" - 14 UNS	90.2	52.7	70.0	30.0	10G10FFORX90L
-12	20	3/4	1.3/16" - 12 UN	118.2	67.2	96.0	36.0	12G12FFORX90L
-16	25	1	1.7/16" - 12 UN	129.9	73.1	114.0	41.0	16G16FFORX90L
-20	32	1.1/4	1.11/16" - 12 UN	140.0	81.0	129.0	50.0	20G20FFORX90L

L: Long drop per ISO 12151-1.

Unless otherwise stated the coupling meets the pressure rating requirements of the respective international standard.

COUPLINGS FOR WIRE AND TEXTILE BRAIDED HOSES MEGACRIMP®

SAE MFFOR

Male SAE flat face 'O' ring.

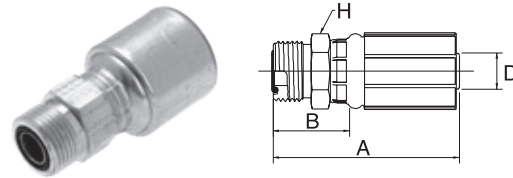

D				A	B	H	REF.
-size	DN	"		mm	mm	mm	G
-4	6	1/4	9/16" - 18 UNF	52.5	26.5	17.0	4G4MFFOR
-4	6	1/4	11/16" - 16 UN	54.0	28.0	19.0	4G6MFFOR
-5	8	5/16	11/16" - 16 UN	56.0	28.0	19.0	5G6MFFOR
-6	10	3/8	11/16" - 16 UN	56.0	28.1	19.0	6G6MFFOR
-6	10	3/8	13/16" - 16 UN	59.0	31.1	22.0	6G8MFFOR
-6	10	3/8	1" - 14 UNS	64.0	36.1	27.0	6G10MFFOR
-8	12	1/2	13/16" - 16 UN	68.2	30.7	22.0	8G8MFFOR
-8	12	1/2	1" - 14 UNS	73.0	35.5	27.0	8G10MFFOR
-10	16	5/8	1" - 14 UNS	73.0	35.5	27.0	10G10MFFOR
-10	16	5/8	1.3/16" - 12 UN	77.0	39.5	32.0	10G12MFFOR
-12	20	3/4	1.3/16" - 12 UN	90.0	39.0	32.0	12G12MFFOR
-12	20	3/4	1.7/16" - 12 UN	95.0	44.0	41.0	12G16MFFOR
-16	25	1	1.7/16" - 12 UN	102.0	45.2	41.0	16G16MFFOR
-16	25	1	1.11/16" - 12 UN	105.0	48.2	46.0	16G20MFFOR
-20	32	1.1/4	1.11/16" - 12 UN	109.0	50.0	46.0	20G20MFFOR

SAE 45° FSX

Female SAE swivel. 45° inverted cone.

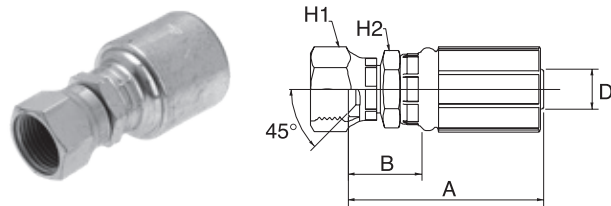

D				A	B	H1	H2	REF.
-size	DN	"		mm	mm	mm	mm	G
-4	6	1/4	7/16" - 20 UNF	48.0	22.0	14.3	12.7	4G4FSX
-4	6	1/4	1/2" - 20 UNF	46.5	20.5	17.5	12.7	4G5FSX
-4	6	1/4	5/8" - 18 UNF	48.5	22.5	19.1	15.9	4G6FSX
-5	8	5/16	5/8" - 18 UNF	52.0	24.0	19.1	15.9	5G6FSX
-6	10	3/8	5/8" - 18 UNF	52.0	24.1	19.1	15.9	6G6FSX
-6	10	3/8	3/4" - 16 UNF	51.5	23.5	22.2	17.5	6G8FSX
-8	12	1/2	3/4" - 16 UNF	60.0	22.5	22.2	20.6	8G8FSX
-8	12	1/2	7/8" - 14 UNF	63.0	25.5	27.0	20.6	8G10FSX
-12	20	3/4	1.1/16" - 14 UNS	78.5	27.5	31.8	27.0	12G12FSX

Unless otherwise stated the coupling meets the pressure rating requirements of the respective international standard.

COUPLINGS FOR WIRE AND TEXTILE BRAIDED HOSES MEGACRIMP®

THE WORLD OF COUPLINGS

SAE 45° FSX45

Female SAE swivel. 45° inverted cone.
45° swept elbow.

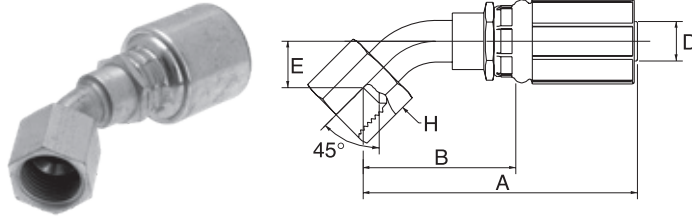

↔			🌀	↔	↔			🔌
D				A	B	E	H	REF.
-size	DN	"		mm	mm	mm	mm	G
-6	10	3/8	5/8" - 18 UNF	69.5	41.6	9.9	19.1	6G6FSX45
-8	12	1/2	3/4" - 16 UNF	84.0	46.5	14.0	22.2	8G8FSX45
-12	20	3/4	1.1/16" - 14 UNS	111.0	60.0	19.8	31.8	12G12FSX45

SAE 45° FSX90

Female SAE swivel. 45° inverted cone.
90° swept elbow.

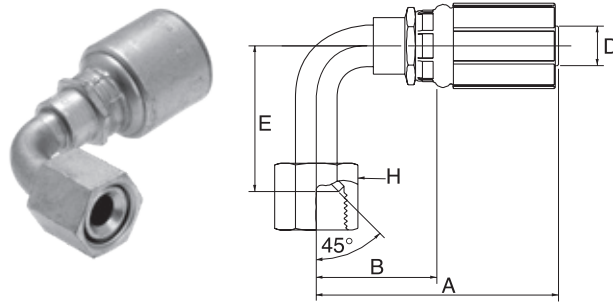

↔			🌀	↔	↔			🔌
D				A	B	E	H	REF.
-size	DN	"		mm	mm	mm	mm	G
-4	6	1/4	7/16" - 20 UNF	52.0	26.0	31.5	14.3	4G4FSX90
-6	10	3/8	5/8" - 18 UNF	60.0	32.1	38.5	19.1	6G6FSX90
-6	10	3/8	3/4" - 16 UNF	63.5	35.6	44.5	22.2	6G8FSX90
-8	12	1/2	3/4" - 16 UNF	74.5	37.0	44.5	22.2	8G8FSX90
-12	20	3/4	1.1/16" - 14 UNS	100.0	49.0	70.5	31.8	12G12FSX90

Unless otherwise stated the coupling meets the pressure rating requirements of the respective international standard.

COUPLINGS FOR WIRE AND TEXTILE BRAIDED HOSES MEGACRIMP®

SAE 45° MS

Male SAE parallel. 45° cone.

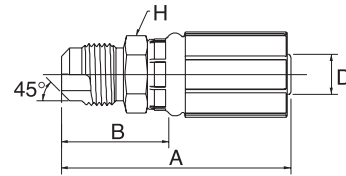

↔			🌀	↔	🌀		REF.
D				A	B	H	REF.
-size	DN	"		mm	mm	mm	G
-4	6	1/4	7/16" - 20 UNF	53.5	27.5	12.7	4G4MS
-6	10	3/8	5/8" - 18 UNF	60.5	32.6	15.9	6G6MS
-8	12	1/2	3/4" - 16 UNF	73.5	36.0	20.6	8G8MS
-8	12	1/2	7/8" - 14 UNF	77.0	39.5	22.2	8G10MS
-12	20	3/4	1.1/16" - 14 UNS	96.0	45.0	27.0	12G12MS

SAE 45° MIX

Male SAE parallel. 45° inverted cone.

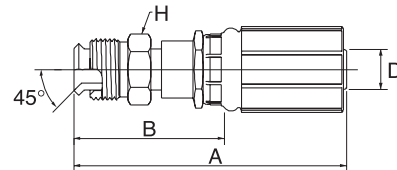

↔			🌀	↔	🌀		REF.
D				A	B	H	REF.
-size	DN	"		mm	mm	mm	G
-4	6	1/4	7/16" - 24 UNS	63.9	37.9	11.1	4G4MIX
-4	6	1/4	1/2" - 20 UNF	63.9	37.9	12.7	4G5MIX
-6	10	3/8	1/2" - 20 UNF	64.9	37.0	12.7	6G5MIX
-6	10	3/8	5/8" - 18 UNF	69.9	42.0	15.9	6G6MIX
-6	10	3/8	11/16" - 18 UNS	70.0	42.1	17.5	6G7MIX
-8	12	1/2	3/4" - 18 UNS	83.8	46.3	19.1	8G8MIX
-10	16	5/8	7/8" - 18 UNS	99.5	62.0	22.2	10G10MIX

Unless otherwise stated the coupling meets the pressure rating requirements of the respective international standard.

COUPLINGS FOR WIRE AND TEXTILE BRAIDED HOSES MEGACRIMP®

THE WORLD OF COUPLINGS

SAE 45° MIX45

Male SAE parallel. 45° inverted cone.
45° swept elbow.

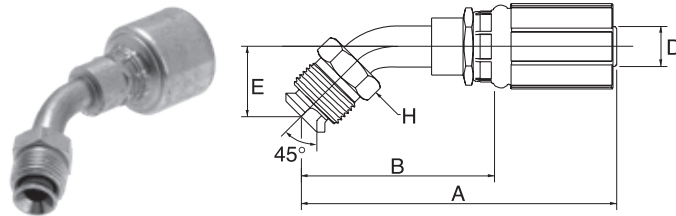

↻			🌀	↔	↔			📏
D				A	B	E	H	REF.
-size	DN	"		mm	mm	mm	mm	G
-6	10	3/8	7/16" - 24 UNS	80.5	52.6	25.4	11.1	6G4MIX45
-6	10	3/8	1/2" - 20 UNF	79.5	51.6	25.4	12.7	6G5MIX45
-6	10	3/8	5/8" - 18 UNF	84.3	56.4	25.4	15.9	6G6MIX45
-6	10	3/8	11/16" - 18 UNS	86.0	58.1	25.4	17.5	6G7MIX45

SAE 45° MIX90

Male SAE parallel. 45° inverted cone.
90° swept elbow.

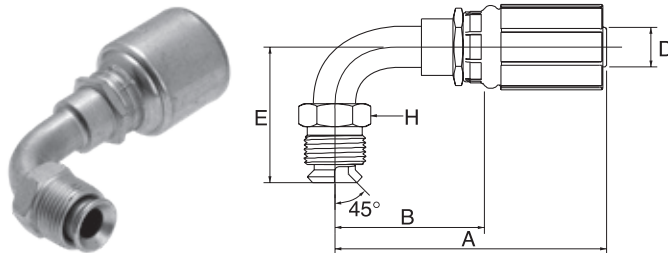

↻			🌀	↔	↔			📏
D				A	B	E	H	REF.
-size	DN	"		mm	mm	mm	mm	G
-4	6	1/4	7/16" - 24 UNS	59.2	33.2	35.1	11.1	4G4MIX90
-4	6	1/4	1/2" - 20 UNF	62.5	36.5	35.1	12.7	4G5MIX90
-6	10	3/8	7/16" - 24 UNS	62.0	34.1	35.1	11.1	6G4MIX90
-6	10	3/8	1/2" - 20 UNF	63.5	35.6	35.1	12.7	6G5MIX90
-6	10	3/8	5/8" - 18 UNF	71.0	43.1	35.1	15.9	6G6MIX90
-6	10	3/8	11/16" - 18 UNS	71.0	43.1	35.1	17.5	6G7MIX90
-8	12	1/2	3/4" - 18 UNS	83.5	46.0	41.7	19.1	8G8MIX90

Unless otherwise stated the coupling meets the pressure rating requirements of the respective international standard.

COUPLINGS FOR WIRE AND TEXTILE BRAIDED HOSES MEGACRIMP®

SAE 24° MFA

Male SAE parallel. 24° inverted cone.

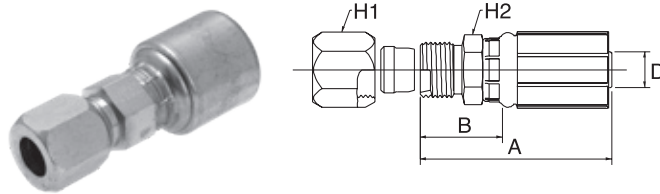

↔			🌀	↔				🌀
D				A	B	H1	H2	REF.
-size	DN	"		mm	mm	mm	mm	G
-4	6	1/4	7/16" - 20 UNF	53.0	27.0	14.3	12.7	4G4MFA
-4	6	1/4	1/2" - 20 UNF	50.0	24.0	15.9	12.7	4G5MFA
-6	10	3/8	7/16" - 20 UNF	55.0	27.1	14.3	15.9	6G4MFA
-6	10	3/8	1/2" - 20 UNF	55.0	27.1	15.9	15.9	6G5MFA
-6	10	3/8	9/16" - 18 UNF	56.0	28.1	17.5	15.9	6G6MFA
-6	10	3/8	3/4" - 16 UNF	61.0	33.1	22.2	19.1	6G8MFA
-8	12	1/2	3/4" - 16 UNF	70.5	33.0	22.2	20.6	8G8MFA
-8	12	1/2	7/8" - 14 UNF	72.0	34.5	25.4	22.2	8G10MFA
-12	20	3/4	1.1/16" - 12 UN	90.0	39.0	31.8	27.0	12G12MFA
-16	25	1	1.5/16" - 12 UN	100.0	43.2	38.1	34.9	16G16MFA

SAE FL

SAE 'O' ring flange. Code 61.

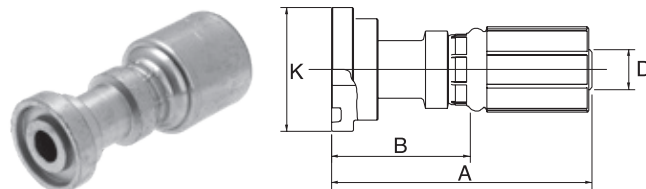

↔			🌀	↔				🌀
D				A	B	K	KIT	REF.
-size	DN	"		mm	mm	mm		G
-8	12	1/2	1/2"	80.0	42.5	30.2	8 PA-FL	8G8FL
-8	12	1/2	3/4"	80.0	42.5	38.1	12 PA-FL	8G12FL
-10	16	5/8	3/4"	98.0	60.5	38.1	12 PA-FL	10G12FL
-12	20	3/4	3/4"	98.0	47.0	38.1	12 PA-FL	12G12FL
-12	20	3/4	1"	88.8	37.8	44.5	16 PA-FL	12G16FL
-16	25	1	3/4"	128.0	71.2	38.1	12 PA-FL	16G12FL
-16	25	1	1"	105.0	48.2	44.5	16 PA-FL	16G16FL
-16	25	1	1.1/4"	105.0	48.2	50.8	20 PA-FL	16G20FL
-16	25	1	1.1/2"	96.0	39.2	60.3	24 PA-FL	16G24FL
-20	32	1.1/4	1.1/4"	112.5	53.5	50.8	20 PA-FL	20G20FL
-20	32	1.1/4	1.1/2"	117.5	58.5	60.3	24 PA-FL	20G24FL

Details on flange kits see page 292.

Unless otherwise stated the coupling meets the pressure rating requirements of the respective international standard.

COUPLINGS FOR WIRE AND TEXTILE BRAIDED HOSES MEGACRIMP®

THE WORLD OF COUPLINGS

SAE FL22

SAE 'O' ring flange. Code 61.
22° swept elbow.

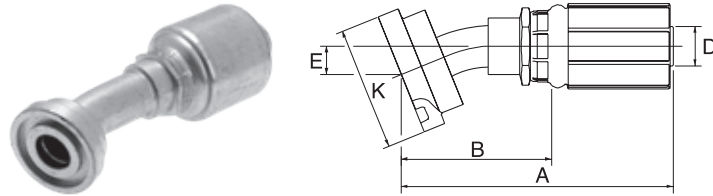

↻			⌋	↔					⌋
D				A	B	E	K	KIT	REF.
-size	DN	"		mm	mm	mm	mm		G
-12	20	3/4	3/4"	121.0	70.0	11.0	38.1	12 PA-FL	12G12FL22M
-16	25	1	1"	142.5	85.7	14.0	44.5	16 PA-FL	16G16FL22M
-20	32	1.1/4	1.1/4"	152.5	93.5	15.0	50.8	20 PA-FL	20G20FL22M

M: Medium drop per ISO 12151-3. / Details on flange kits see page 292.

SAE FL30

SAE 'O' ring flange. Code 61.
30° swept elbow.

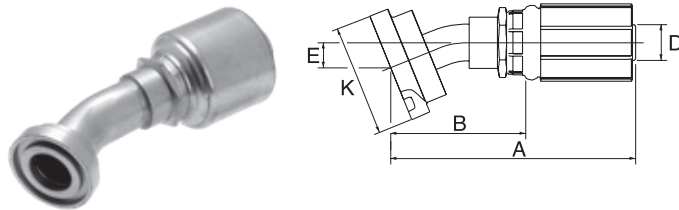

↻			⌋	↔					⌋
D				A	B	E	K	KIT	REF.
-size	DN	"		mm	mm	mm	mm		G
-16	25	1	1"	144.5	87.7	19.0	44.5	16 PA-FL	16G16FL30M

M: Medium drop per ISO 12151-3. / Details on flange kits see page 292.

Unless otherwise stated the coupling meets the pressure rating requirements of the respective international standard.

COUPLINGS FOR WIRE AND TEXTILE BRAIDED HOSES MEGACRIMP®

SAE FL45

SAE 'O' ring flange. Code 61.
45° swept elbow.

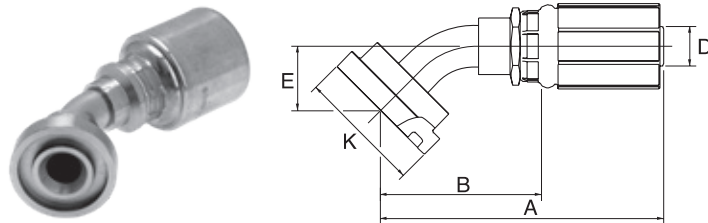

↻			⊕	↔					⊕
D				A	B	E	K	KIT	REF.
-size	DN	"		mm	mm	mm	mm		G
-8	12	1/2	1/2"	84.9	47.5	21.7	30.2	8 PA-FL	8G8FL45M
-8	12	1/2	3/4"	104.8	67.3	26.0	38.1	12 PA-FL	8G12FL45M
-12	20	3/4	3/4"	107.2	56.2	26.6	38.1	12 PA-FL	12G12FL45M
-12	20	3/4	1"	124.5	73.5	28.0	44.5	16 PA-FL	12G16FL45S
-16	25	1	3/4"	118.7	61.9	26.6	38.1	12 PA-FL	16G12FL45M
-16	25	1	1"	142.5	85.7	28.0	44.5	16 PA-FL	16G16FL45S
-16	25	1	1.1/4"	149.0	92.2	32.0	50.8	20 PA-FL	16G20FL45S
-20	32	1.1/4	1.1/4"	157.0	98.0	32.0	50.8	20 PA-FL	20G20FL45S

S: Short drop - M: Medium drop per ISO 12151-3. / Details on flange kits see page 292.

SAE FL60

SAE 'O' ring flange. Code 61.
60° swept elbow.

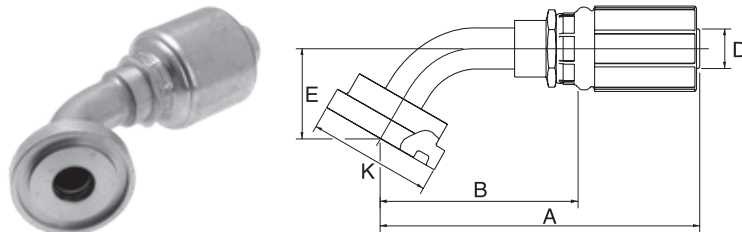

↻			⊕	↔					⊕
D				A	B	E	K	KIT	REF.
-size	DN	"		mm	mm	mm	mm		G
-12	20	3/4	3/4"	128.0	77.0	37.0	38.1	12 PA-FL	12G12FL60M
-12	20	3/4	1"	132.0	81.0	44.0	44.5	16 PA-FL	12G16FL60M

M: Medium drop per ISO 12151-3. / Details on flange kits see page 292.

Unless otherwise stated the coupling meets the pressure rating requirements of the respective international standard.

COUPLINGS FOR WIRE AND TEXTILE BRAIDED HOSES MEGACRIMP®

THE WORLD OF COUPLINGS

SAE FL90

SAE 'O' ring flange. Code 61.
90° swept elbow.

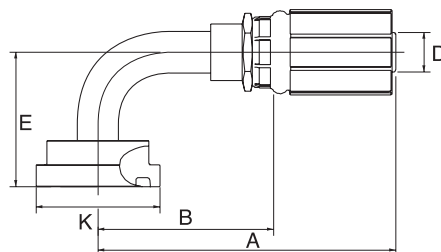

↻			🔧	↔					🔧
D				A	B	E	K	KIT	REF.
-size	DN	"		mm	mm	mm	mm		G
-8	12	1/2	1/2"	91.2	53.7	40.0	30.2	8 PA-FL	8G8FL90M
-8	12	1/2	3/4"	91.5	54.0	58.0	38.1	12 PA-FL	8G12FL90M
-10	16	5/8	3/4"	101.8	64.3	58.0	38.1	12 PA-FL	10G12FL90M
-12	20	3/4	3/4"	97.3	46.3	54.4	38.1	12 PA-FL	12G12FL90-054
-12	20	3/4	1"	119.8	68.8	61.0	44.5	16 PA-FL	12G16FL90S
-16	25	1	1"	139.3	82.5	61.0	44.5	16 PA-FL	16G16FL90S
-16	25	1	1.1/4"	139.3	82.5	68.0	50.8	20 PA-FL	16G20FL90S
-16	25	1	1.1/2"	118.2	61.4	61.6	60.3	24 PA-FL	16G24FL90
-20	32	1.1/4	1"	122.1	63.1	61.8	44.5	16 PA-FL	20G16FL90S
-20	32	1.1/4	1.1/4"	158.1	99.1	68.0	50.8	20 PA-FL	20G20FL90S
-20	32	1.1/4	1.1/2"	158.1	99.1	81.0	60.3	24 PA-FL	20G24FL90S

S: Short drop - M: Medium drop per ISO 12151-3. / Details on flange kits see page 292.

Unless otherwise stated the coupling meets the pressure rating requirements of the respective international standard.

COUPLINGS FOR WIRE AND TEXTILE BRAIDED HOSES MEGACRIMP®

FLK

Komatsu type 'O' ring flange.

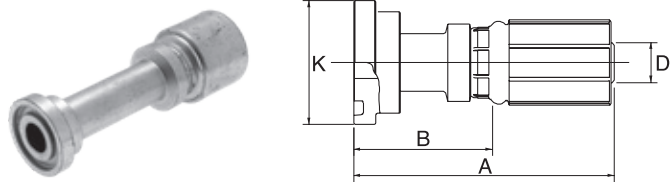

D				A B K			REF.
-size	DN	"		mm	mm	mm	G
-8	12	1/2	5/8"	80.0	42.5	34.2	8G10FLK
-10	16	5/8	5/8"	119.0	81.5	34.2	10G10FLK

FLK45

Komatsu type 'O' ring flange.
45° swept elbow.

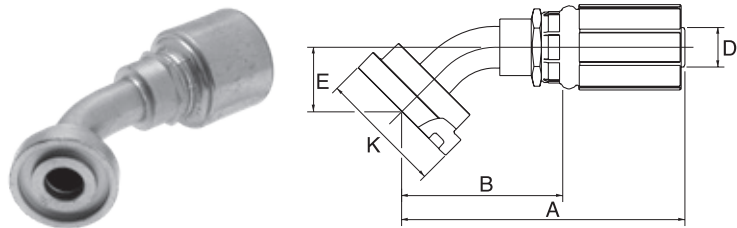

D				A B E K				REF.
-size	DN	"		mm	mm	mm	mm	G
-10	16	5/8	5/8"	106.5	69.0	26.0	34.2	10G10FLK45

FLK90

Komatsu type 'O' ring flange.
90° swept elbow.

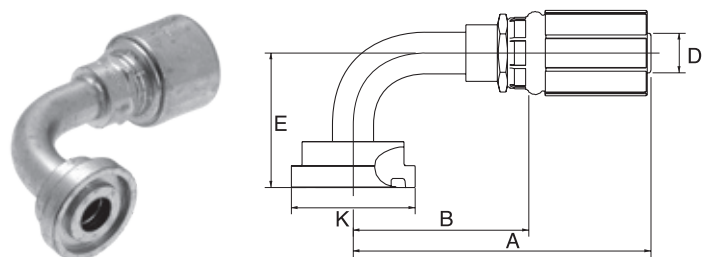

D				A B E K				REF.
-size	DN	"		mm	mm	mm	mm	G
-10	16	5/8	5/8"	99.0	61.5	55.0	34.2	10G10FLK90

Unless otherwise stated the coupling meets the pressure rating requirements of the respective international standard.

COUPLINGS FOR WIRE AND TEXTILE BRAIDED HOSES MEGACRIMP®

THE WORLD OF COUPLINGS

DIN 24° FDLORX

Female DIN 'O' ring swivel. 24° cone.
Light series.

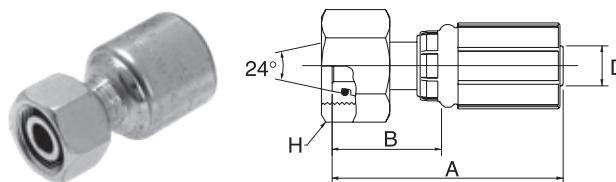

↻			🌀	↔	🌀		REF.
-size	DN	"		A mm	B mm	H mm	G
-4	6	1/4	M12 x 1.5	50.5	24.5	14.0	4G6FDLORX
-4	6	1/4	M14 x 1.5	52.5	26.5	17.0	4G8FDLORX
-4	6	1/4	M16 x 1.5	53.5	27.5	19.0	4G10FDLORX
-4	6	1/4	M18 x 1.5	52.5	26.5	22.0	4G12FDLORX
-5	8	5/16	M14 x 1.5	52.0	28.4	17.0	5G8FDLORX
-5	8	5/16	M16 x 1.5	53.9	29.7	19.0	5G10FDLORX
-5	8	5/16	M18 x 1.5	58.5	30.0	22.0	5G12FDLORX
-6	10	3/8	M16 x 1.5	55.0	27.1	19.0	6G10FDLORX
-6	10	3/8	M18 x 1.5	55.5	27.6	22.0	6G12FDLORX
-6	10	3/8	M20 x 1.5	58.0	30.1	24.0	6G14FDLORX
-6	10	3/8	M22 x 1.5	54.0	26.1	27.0	6G15FDLORX
-8	12	1/2	M18 x 1.5	70.2	32.7	22.0	8G12FDLORX
-8	12	1/2	M22 x 1.5	63.5	26.0	27.0	8G15FDLORX
-8	12	1/2	M26 x 1.5	65.0	27.5	32.0	8G18FDLORX
-10	16	5/8	M26 x 1.5	67.0	29.5	32.0	10G18FDLORX
-12	20	3/4	M26 x 1.5	81.5	30.5	32.0	12G18FDLORX
-12	20	3/4	M30 x 2.0	83.5	32.5	36.0	12G22FDLORX
-16	25	1	M36 x 2.0	81.6	36.7	41.0	16G28FDLORX
-20	32	1.1/4	M45 x 2.0	90.4	44.1	50.0	20G35FDLORX

Unless otherwise stated the coupling meets the pressure rating requirements of the respective international standard.

COUPLINGS FOR WIRE AND TEXTILE BRAIDED HOSES MEGACRIMP®

DIN 24° FDLORX45

Female DIN 'O' ring swivel. 24° cone.
Light series. 45° swept elbow.

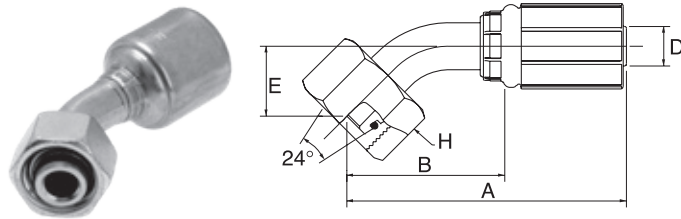

↻			🌀	↔				📏
D				A	B	E	H	REF.
-size	DN	"		mm	mm	mm	mm	G
-4	6	1/4	M12 x 1.5	65.8	39.7	16.9	14.0	4G6FDLORX45
-4	6	1/4	M14 x 1.5	65.1	39.0	16.2	17.0	4G8FDLORX45
-4	6	1/4	M16 x 1.5	66.9	40.8	17.9	19.0	4G10FDLORX45
-4	6	1/4	M18 x 1.5	67.2	41.2	18.3	22.0	4G12FDLORX45
-5	8	5/16	M14 x 1.5	67.1	39.1	16.9	17.0	5G8FDLORX45
-5	8	5/16	M16 x 1.5	63.4	39.3	17.1	19.0	5G10FDLORX45
-5	8	5/16	M18 x 1.5	67.7	39.7	18.9	22.0	5G12FDLORX45
-6	10	3/8	M16 x 1.5	68.5	40.5	18.6	19.0	6G10FDLORX45
-6	10	3/8	M18 x 1.5	68.8	40.9	18.9	22.0	6G12FDLORX45
-6	10	3/8	M22 x 1.5	72.3	44.4	22.5	27.0	6G15FDLORX45
-8	12	1/2	M18 x 1.5	92.9	55.4	29.7	22.0	8G12FDLORX45
-8	12	1/2	M22 x 1.5	84.4	47.0	20.2	27.0	8G15FDLORX45
-8	12	1/2	M26 x 1.5	94.6	57.1	26.9	32.0	8G18FDLORX45
-10	16	5/8	M26 x 1.5	93.5	56.2	24.8	32.0	10G18FDLORX45
-12	20	3/4	M30 x 2.0	117.1	66.1	29.8	36.0	12G22FDLORX45
-16	25	1	M36 x 2.0	123.7	78.8	30.9	41.0	16G28FDLORX45
-20	32	1.1/4	M45 x 2.0	161.9	102.9	37.5	50.0	20G35FDLORX45

Unless otherwise stated the coupling meets the pressure rating requirements of the respective international standard.

COUPLINGS FOR WIRE AND TEXTILE BRAIDED HOSES MEGACRIMP®

THE WORLD OF COUPLINGS

DIN 24° FDLORX90

Female DIN 'O' ring swivel. 24° cone.
Light series. 90° swept elbow.

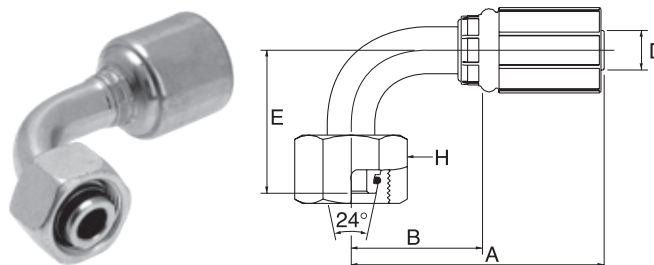

↻			🌀	↔				🔧
D				A	B	E	H	REF.
-size	DN	"		mm	mm	mm	mm	G
-4	6	1/4	M12 x 1.5	60.0	34.0	35.0	14.0	4G6FDLORX90
-4	6	1/4	M14 x 1.5	60.0	34.0	35.0	17.0	4G8FDLORX90
-4	6	1/4	M16 x 1.5	60.0	34.0	36.5	19.0	4G10FDLORX90
-4	6	1/4	M18 x 1.5	60.0	34.0	37.0	22.0	4G12FDLORX90
-5	8	5/16	M14 x 1.5	61.4	33.4	35.0	17.0	5G8FDLORX90
-5	8	5/16	M16 x 1.5	58.6	34.4	36.5	19.0	5G10FDLORX90
-5	8	5/16	M15 x 1.5	59.0	31.0	37.0	22.0	5G12FDLORX90
-6	10	3/8	M16 x 1.5	60.1	32.2	36.5	19.0	6G10FDLORX90
-6	10	3/8	M18 x 1.5	60.1	32.2	37.0	22.0	6G12FDLORX90
-6	10	3/8	M22 x 1.5	60.1	32.2	42.0	27.0	6G15FDLORX90
-8	12	1/2	M18 x 1.5	74.3	36.9	53.1	22.0	8G12FDLORX90
-8	12	1/2	M22 x 1.5	77.8	40.3	42.0	27.0	8G15FDLORX90
-8	12	1/2	M26 x 1.5	81.4	43.9	51.5	32.0	8G18FDLORX90
-10	16	5/8	M26 x 1.5	85.1	47.8	51.5	32.0	10G18FDLORX90
-12	20	3/4	M26 x 1.5	100.3	49.3	51.5	32.0	12G18FDLORX90
-12	20	3/4	M30 x 2.0	107.3	56.3	62.0	36.0	12G22FDLORX90
-16	25	1	M36 x 2.0	119.2	74.3	70.0	41.0	16G28FDLORX90
-20	32	1.1/4	M45 x 2.0	151.4	92.4	80.0	50.0	20G35FDLORX90

Unless otherwise stated the coupling meets the pressure rating requirements of the respective international standard.

COUPLINGS FOR WIRE AND TEXTILE BRAIDED HOSES MEGACRIMP®

DIN 24° MDL

Male DIN parallel. 24° inverted cone.
Light series.

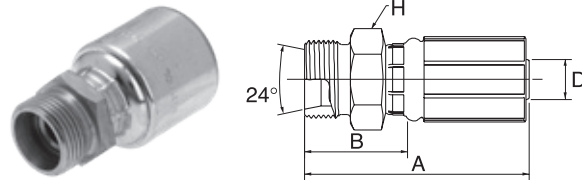

↔			🌀	↔	🌀		
D				A	B	H	REF.
-size	DN	"		mm	mm	mm	G
-4	6	1/4	M12 x 1.5	42.9	19.8	14.0	4G6MDL
-4	6	1/4	M14 x 1.5	43.9	20.8	17.0	4G8MDL
-4	6	1/4	M16 x 1.5	44.9	21.8	17.0	4G10MDL
-4	6	1/4	M18 x 1.5	47.1	24.0	19.0	4G12MDL
-5	8	5/16	M14 x 1.5	44.7	20.8	17.0	5G8MDL
-5	8	5/16	M16 x 1.5	45.9	21.8	17.0	5G10MDL
-5	8	5/16	M18 x 1.5	46.7	22.8	19.0	5G12MDL
-6	10	3/8	M16 x 1.5	45.3	21.9	17.0	6G10MDL
-6	10	3/8	M18 x 1.5	46.3	22.9	19.0	6G12MDL
-6	10	3/8	M22 x 1.5	47.3	23.9	24.0	6G15MDL
-8	12	1/2	M18 x 1.5	55.6	23.1	22.0	8G12MDL
-8	12	1/2	M22 x 1.5	56.5	24.0	24.0	8G15MDL
-8	12	1/2	M26 x 1.5	58.0	25.5	27.0	8G18MDL
-10	16	5/8	M26 x 1.5	64.0	26.5	27.0	10G18MDL
-12	20	3/4	M26 x 1.5	78.0	27.0	27.0	12G18MDL
-12	20	3/4	M30 x 2.0	80.0	29.0	32.0	12G22MDL
-16	25	1	M36 x 2.0	76.3	30.4	41.0	16G28MDL
-20	32	1.1/4	M45 x 2.0	80.4	35.1	46.0	20G35MDL

Unless otherwise stated the coupling meets the pressure rating requirements of the respective international standard.

COUPLINGS FOR WIRE AND TEXTILE BRAIDED HOSES MEGACRIMP®

THE WORLD OF COUPLINGS

DIN 24° FDHORX

Female DIN 'O' ring swivel. 24° cone.
Heavy series.

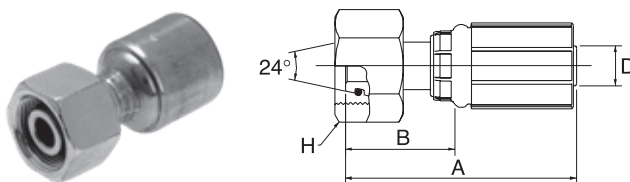

↻			🌀	↔	🌀		REF.
-size	D DN	"		A mm	B mm	H mm	G
-4	6	1/4	M14 x 1.5	50.5	24.5	17.0	4G6FDHORX
-4	6	1/4	M16 x 1.5	52.5	26.5	19.0	4G8FDHORX
-4	6	1/4	M18 x 1.5	53.5	27.5	22.0	4G10FDHORX
-4	6	1/4	M20 x 1.5	52.5	26.5	24.0	4G12FDHORX
-5	8	5/16	M18 x 1.5	54.1	29.9	22.0	5G10FDHORX
-5	8	5/16	M20 x 1.5	58.0	30.0	24.0	5G12FDHORX
-5	8	5/16	M22 x 1.5	53.6	30.0	27.0	5G14FDHORX
-6	10	3/8	M18 x 1.5	55.0	27.1	22.0	6G10FDHORX
-6	10	3/8	M20 x 1.5	55.5	27.6	24.0	6G12FDHORX
-6	10	3/8	M22 x 1.5	58.0	30.1	27.0	6G14FDHORX
-8	12	1/2	M20 x 1.5	70.2	32.7	24.0	8G12FDHORX
-8	12	1/2	M22 x 1.5	68.0	30.5	27.0	8G14FDHORX
-8	12	1/2	M24 x 1.5	69.0	31.5	30.0	8G16FDHORX
-8	12	1/2	M30 x 2.0	70.0	32.5	36.0	8G20FDHORX
-10	16	5/8	M24 x 1.5	71.0	33.5	30.0	10G16FDHORX
-10	16	5/8	M30 x 2.0	73.0	35.5	36.0	10G20FDHORX
-12	20	3/4	M30 x 2.0	89.5	38.5	36.0	12G20FDHORX
-12	20	3/4	M36 x 2.0	90.0	39.0	46.0	12G25FDHORX
-16	25	1	M36 x 2.0	102.5	45.7	46.0	16G25FDHORX
-16	25	1	M42 x 2.0	94.1	49.2	50.0	16G30FDHORX
-20	32	1.1/4	M52 x 2.0	104.1	57.8	60.0	20G38FDHORX

Unless otherwise stated the coupling meets the pressure rating requirements of the respective international standard.

COUPLINGS FOR WIRE AND TEXTILE BRAIDED HOSES MEGACRIMP®

DIN 24° FDHORX45

Female DIN 'O' ring swivel. 24° cone.
Heavy series. 45° swept elbow.

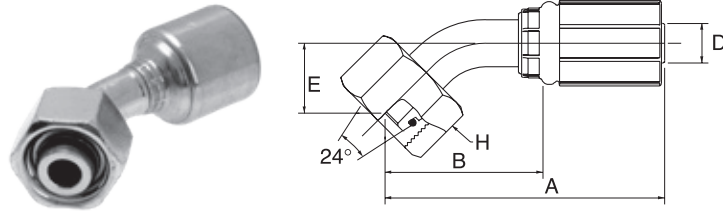

↻			🌀	↔	🌀			REF.
-size	D			A	B	E	H	G
	DN	"		mm	mm	mm	mm	
-4	6	1/4	M16 x 1.5	65.1	39.0	16.2	19.0	4G8FDHORX45
-4	6	1/4	M18 x 1.5	66.9	40.8	17.9	22.0	4G10FDHORX45
-4	6	1/4	M20 x 1.5	67.2	41.2	18.3	24.0	4G12FDHORX45
-5	8	5/16	M18 x 1.5	63.3	39.3	17.1	22.0	5G10FDHORX45
-5	8	5/16	M20 x 1.5	67.7	39.7	18.9	24.0	5G12FDHORX45
-6	10	3/8	M18 x 1.5	68.5	40.5	18.6	22.0	6G10FDHORX45
-6	10	3/8	M20 x 1.5	68.8	40.9	18.9	24.0	6G12FDHORX45
-6	10	3/8	M22 x 1.5	70.9	43.0	21.0	27.0	6G14FDHORX45
-8	12	1/2	M22 x 1.5	91.3	53.9	27.1	27.0	8G14FDHORX45
-8	12	1/2	M24 x 1.5	85.9	48.4	21.6	30.0	8G16FDHORX45
-10	16	5/8	M30 x 2.0	93.1	55.8	24.9	36.0	10G20FDHORX45
-12	20	3/4	M30 x 2.0	109.4	58.4	24.9	36.0	12G20FDHORX45
-12	20	3/4	M36 x 2.0	118.6	67.6	31.2	46.0	12G25FDHORX45
-16	25	1	M36 x 2.0	146.5	89.7	35.1	46.0	16G25FDHORX45
-16	25	1	M42 x 2.0	139.8	83.0	35.1	50.0	16G30FDHORX45
-20	32	1.1/4	M52 x 2.0	166.9	107.9	42.5	60.0	20G38FDHORX45

Unless otherwise stated the coupling meets the pressure rating requirements of the respective international standard.





COUPLINGS FOR WIRE AND TEXTILE BRAIDED HOSES MEGACRIMP®

THE WORLD OF COUPLINGS

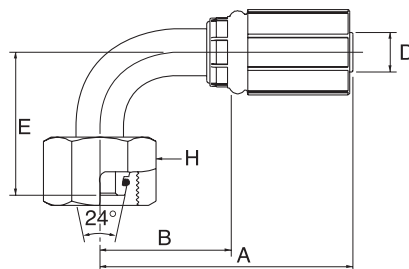
DIN 24° FDHORX90

Female DIN 'O' ring swivel. 24° cone.
Heavy series. 90° swept elbow.



								
D				A	B	E	H	REF.
-size	DN	"		mm	mm	mm	mm	G
-4	6	1/4	M14 x 1.5	60.0	34.0	35.0	17.0	4G6FDHORX90
-4	6	1/4	M16 x 1.5	60.0	34.0	35.0	19.0	4G8FDHORX90
-4	6	1/4	M18 x 1.5	60.0	34.0	36.5	22.0	4G10FDHORX90
-4	6	1/4	M20 x 1.5	60.0	34.0	37.0	24.0	4G12FDHORX90
-5	8	5/16	M18 x 1.5	58.5	34.4	36.5	22.0	5G10FDHORX90
-5	8	5/16	M20 x 1.5	59.0	31.0	37.0	24.0	5G12FDHORX90
-5	8	5/16	M22 x 1.5	54.6	31.0	40.0	27.0	5G14FDHORX90
-6	10	3/8	M18 x 1.5	60.1	32.2	36.5	22.0	6G10FDHORX90
-6	10	3/8	M20 x 1.5	60.1	32.2	37.0	24.0	6G12FDHORX90
-6	10	3/8	M22 x 1.5	60.3	32.4	40.0	27.0	6G14FDHORX90
-8	12	1/2	M24 x 1.5	77.8	40.3	44.0	30.0	8G16FDHORX90
-10	16	5/8	M30 x 2.0	84.1	46.8	51.0	36.0	10G20FDHORX90
-12	20	3/4	M30 X 2.0	100.3	49.3	51.0	36.0	12G20FDHORX90
-12	20	3/4	M36 x 2.0	107.3	56.3	64.0	46.0	12G25FDHORX90
-16	25	1	M36 x 2.0	137.8	81.0	76.0	46.0	16G25FDHORX90
-16	25	1	M42 x 2.0	119.2	74.3	76.0	50.0	16G30FDHORX90
-20	32	1.1/4	M52 x 2.0	151.4	92.4	87.0	60.0	20G38FDHORX90

Unless otherwise stated the coupling meets the pressure rating requirements of the respective international standard.

COUPLINGS FOR WIRE AND TEXTILE BRAIDED HOSES MEGACRIMP®

DIN 24° MDH

Male DIN parallel. 24° inverted cone.
Heavy series.

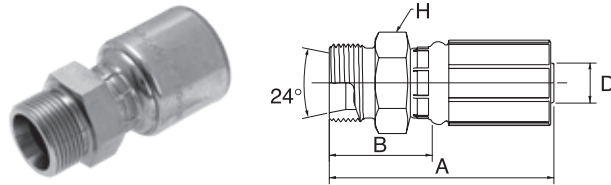

↔			🌀	↔	🌀		
D				A	B	H	REF.
-size	DN	"		mm	mm	mm	G
-4	6	1/4	M16 x 1.5	53.0	27.0	17.0	4G8MDH
-4	6	1/4	M18 x 1.5	52.5	26.5	19.0	4G10MDH
-5	8	5/16	M18 x 1.5	49.7	25.8	19.0	5G10MDH
-5	8	5/16	M20 x 1.5	51.9	27.8	22.0	5G12MDH
-6	10	3/8	M18 x 1.5	55.0	27.1	19.0	6G10MDH
-6	10	3/8	M20 x 1.5	57.5	29.6	24.0	6G12MDH
-6	10	3/8	M22 x 1.5	59.5	31.6	24.0	6G14MDH
-8	12	1/2	M20 x 1.5	61.5	29.0	24.0	8G12MDH
-8	12	1/2	M24 x 1.5	69.0	31.5	27.0	8G16MDH
-10	16	5/8	M30 x 2.0	73.0	35.5	32.0	10G20MDH
-12	20	3/4	M30 x 2.0	87.0	36.0	32.0	12G20MDH
-12	20	3/4	M36 x 2.0	91.0	40.0	41.0	12G25MDH
-16	25	1	M36 x 2.0	86.3	40.4	41.0	16G25MDH
-16	25	1	M42 x 2.0	88.3	42.4	46.0	16G30MDH
-20	32	1.1/4	M52 X 2.0	94.4	49.1	55.0	20G38MDH

METRIC MSP

Metric standpipe.

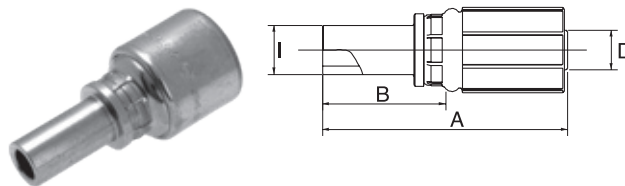

↔			↔	🌀		
D			I	A	B	REF.
-size	DN	"	mm	mm	mm	G
-4	6	1/4	L6	62.5	36.5	4G6MSP
-4	6	1/4	L8	62.5	36.5	4G8MSP
-4	6	1/4	L10	64.5	38.5	4G10MSP
-5	8	5/16	L8	64.5	36.5	5G8MSP
-5	8	5/16	L10	66.5	38.5	5G10MSP
-5	8	5/16	L12	66.5	38.5	5G12MSP
-6	10	3/8	L10	66.5	38.6	6G10MSP
-6	10	3/8	L12	66.5	38.6	6G12MSP
-8	12	1/2	L15	76.3	38.8	8G15MSP
-10	16	5/8	L18	77.0	39.5	10G18MSP
-12	20	3/4	L22	93.0	42.0	12G22MSP

Unless otherwise stated the coupling meets the pressure rating requirements of the respective international standard.

COUPLINGS FOR WIRE AND TEXTILE BRAIDED HOSES MEGACRIMP®

THE WORLD OF COUPLINGS

METRIC DBJ

Metric banjo.

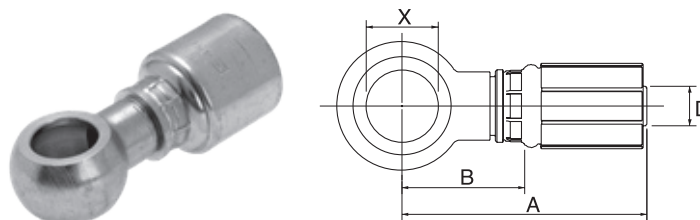

↔			↻	↔	↻		
D				A	B	X	REF.
-size	DN	"		mm	mm	mm	G
-4	6	1/4	M10	52.3	26.3	10.1	4G10DBJ
-4	6	1/4	M12	54.3	28.3	12.1	4G12DBJ
-4	6	1/4	M14	56.3	30.3	14.1	4G14DBJ
-4	6	1/4	M16	58.3	32.3	16.1	4G16DBJ
-4	6	1/4	M18	60.3	34.3	18.1	4G18DBJ
-5	8	5/16	M12	56.2	28.2	12.1	5G12DBJ
-5	8	5/16	M14	58.2	30.2	14.1	5G14DBJ
-5	8	5/16	M16	60.2	32.2	16.1	5G16DBJ
-5	8	5/16	M18	62.2	34.2	18.1	5G18DBJ
-6	10	3/8	M12	56.0	28.1	12.1	6G12DBJ
-6	10	3/8	M14	58.3	30.4	14.1	6G14DBJ
-6	10	3/8	M16	60.3	32.4	16.1	6G16DBJ
-6	10	3/8	M18	62.3	34.4	18.1	6G18DBJ
-6	10	3/8	M22	63.8	35.9	22.1	6G22DBJ
-8	12	1/2	M18	72.2	34.7	18.1	8G18DBJ
-8	12	1/2	M22	75.7	38.2	22.1	8G22DBJ
-10	16	5/8	M22	76.2	38.7	22.1	10G22DBJ
-12	20	3/4	M22	89.2	38.2	22.1	12G22DBJ
-12	20	3/4	M26	94.7	43.7	26.1	12G26DBJ
-16	25	1	M30	109.2	52.4	30.1	16G30DBJ

-4 to -16 size are 10.0 MPa (1450 psi).

Unless otherwise stated the coupling meets the pressure rating requirements of the respective international standard.

COUPLINGS FOR WIRE AND TEXTILE BRAIDED HOSES MEGACRIMP®

NPTF FPX

Female NPSM pipe swivel. 30° cone.

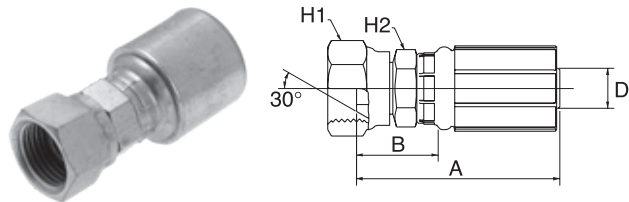

↔			🌀	↔	↔			🌀
D				A	B	H1	H2	REF.
-size	DN	"		mm	mm	mm	mm	G
-4	6	1/4	1/4" - 18 NPSM	51.0	25.0	17.5	12.7	4G4FPX
-6	10	3/8	3/8" - 18 NPSM	56.0	28.1	22.2	15.9	6G6FPX
-8	12	1/2	1/2" - 14 NPSM	64.5	27.0	25.4	20.7	8G8FPX
-12	20	3/4	3/4" - 14 NPSM	84.5	33.5	31.8	27.0	12G12FPX
-16	25	1	1" - 11.5 NPSM	94.0	37.2	38.1	34.9	16G16FPX

NPTF MP

Male NPTF pipe.

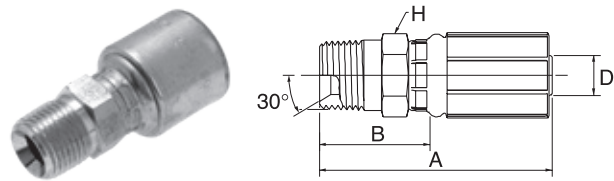

↔			🌀	↔	↔			🌀
D				A	B	H	REF.	
-size	DN	"		mm	mm	mm	G	
-4	6	1/4	1/8" - 27 NPTF	50.0	24.0	12.7	4G2MP	
-4	6	1/4	1/4" - 18 NPTF	55.0	29.0	14.3	4G4MP	
-4	6	1/4	3/8" - 18 NPTF	55.0	29.0	17.5	4G6MP	
-4	6	1/4	1/2" - 14 NPTF	62.0	36.0	22.2	4G8MP	
-5	8	5/16	1/4" - 18 NPTF	58.0	30.0	15.9	5G4MP	
-5	8	5/16	3/8" - 18 NPTF	59.0	31.0	17.5	5G6MP	
-6	10	3/8	1/4" - 18 NPTF	59.0	31.1	15.9	6G4MP	
-6	10	3/8	3/8" - 18 NPTF	59.0	31.1	17.5	6G6MP	
-6	10	3/8	1/2" - 14 NPTF	64.0	36.1	22.2	6G8MP	
-8	12	1/2	3/8" - 18 NPTF	69.0	31.5	20.6	8G6MP	
-8	12	1/2	1/2" - 14 NPTF	73.0	35.5	22.2	8G8MP	
-8	12	1/2	3/4" - 14 NPTF	75.0	37.5	27.0	8G12MP	
-10	16	5/8	1/2" - 14 NPTF	75.0	37.5	23.8	10G8MP	
-10	16	5/8	3/4" - 14 NPTF	75.0	37.5	27.0	10G12MP	
-12	20	3/4	1/2" - 14 NPTF	88.0	37.0	27.0	12G8MP	
-12	20	3/4	3/4" - 14 NPTF	88.0	37.0	27.0	12G12MP	
-12	20	3/4	1" - 11.5 NPTF	96.0	45.0	34.9	12G16MP	
-16	25	1	3/4" - 14 NPTF	100.0	43.2	34.9	16G12MP	
-16	25	1	1" - 11.5 NPTF	104.5	47.7	34.9	16G16MP	
-20	32	1.1/4	1.1/4" - 11.5 NPTF	113.0	54.0	44.5	20G20MP	

Warning: Use only in NPTF connections. Do not use in oil field (API) connections. Blow apart of an oil field connection can result in serious injuries.

Unless otherwise stated the coupling meets the pressure rating requirements of the respective international standard.

COUPLINGS FOR WIRE AND TEXTILE BRAIDED HOSES MEGACRIMP®

THE WORLD OF COUPLINGS

NPTF MPLN

Male NPTF pipe (Long Nose).

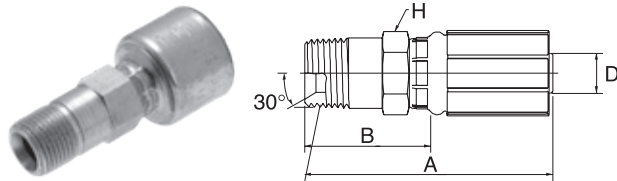

↔			🌀	↔	🌀		REF.
-size	DN	"		A mm	B mm	H mm	G
-4	6	1/4	1/4" - 18 NPTF	65.0	39.0	14.3	4G4MPLN
-4	6	1/4	3/8" - 18 NPTF	65.0	39.0	17.5	4G6MPLN
-6	10	3/8	1/4" - 18 NPTF	69.0	41.1	15.9	6G4MPLN
-6	10	3/8	3/8" - 18 NPTF	69.0	41.1	17.5	6G6MPLN

NPTF FP

Female NPTF pipe.

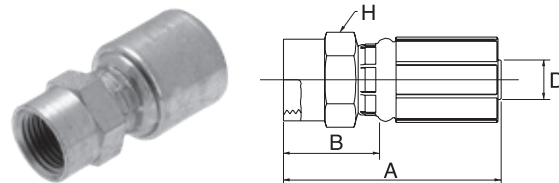

↔			🌀	↔	🌀		REF.
-size	DN	"		A mm	B mm	H mm	G
-4	6	1/4	1/8" - 27 NPTF	44.3	18.3	14.3	4G2FP
-4	6	1/4	1/4" - 18 NPTF	50.5	24.5	17.5	4G4FP
-4	6	1/4	3/8" - 18 NPTF	50.5	24.5	20.6	4G6FP
-6	10	3/8	1/4" - 18 NPTF	51.0	23.1	17.5	6G4FP
-6	10	3/8	3/8" - 18 NPTF	52.5	24.6	20.6	6G6FP
-6	10	3/8	1/2" - 14 NPTF	57.1	29.2	25.4	6G8FP
-8	12	1/2	3/8" - 18 NPTF	62.5	25.0	20.6	8G6FP
-8	12	1/2	1/2" - 14 NPTF	67.0	29.5	25.4	8G8FP
-12	20	3/4	3/4" - 14 NPTF	82.0	31.0	31.8	12G12FP

Unless otherwise stated the coupling meets the pressure rating requirements of the respective international standard.

COUPLINGS FOR WIRE AND TEXTILE BRAIDED HOSES MEGACRIMP®

NPTF MPX

Male NPTF pipe swivel.

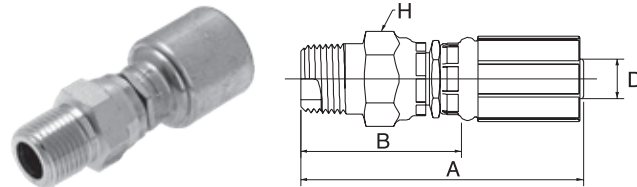

D				A	B	H	REF.
-size	DN	"		mm	mm	mm	G
-4	6	1/4	1/4" - 18 NPTF	66.3	40.2	17.5	4G4MPX
-4	6	1/4	3/8" - 18 NPTF	69.5	43.5	22.2	4G6MPX
-4	6	1/4	1/2" - 14 NPTF	75.4	49.4	25.4	4G8MPX
-6	10	3/8	1/4" - 18 NPTF	72.8	44.9	22.2	6G4MPX
-6	10	3/8	3/8" - 18 NPTF	71.5	43.6	22.2	6G6MPX
-6	10	3/8	1/2" - 14 NPTF	77.4	49.5	25.4	6G8MPX
-8	12	1/2	3/8" - 18 NPTF	82.0	44.6	22.2	8G6MPX
-8	12	1/2	1/2" - 14 NPTF	86.9	49.4	25.4	8G8MPX
-10	16	5/8	3/4" - 14 NPTF	88.5	51.1	33.3	10G12MPX
-12	20	3/4	1/2" - 14 NPTF	100.9	49.9	27.0	12G8MPX
-12	20	3/4	3/4" - 14 NPTF	102.0	51.0	33.3	12G12MPX
-16	25	1	1" - 11.5 NPTF	120.2	63.4	41.3	16G16MPX

Note: Internal seal rings are NBR material. Coupling cannot be swivelled under pressure. Not to be used as a live swivel.

NPTF MPX90

Male NPTF pipe swivel.
90° block elbow.

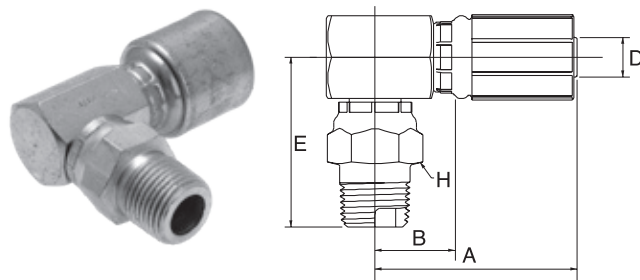

D				A	B	E	H	REF.
-size	DN	"		mm	mm	mm	mm	G
-4	6	1/4	1/4" - 18 NPTF	44.5	18.4	41.3	17.5	4G4MPX90
-4	6	1/4	3/8" - 18 NPTF	46.3	20.2	44.0	22.2	4G6MPX90
-6	10	3/8	1/4" - 18 NPTF	49.7	21.7	42.1	17.5	6G4MPX90
-6	10	3/8	3/8" - 18 NPTF	49.7	21.7	44.8	22.2	6G6MPX90
-6	10	3/8	1/2" - 14 NPTF	49.7	21.7	49.1	25.4	6G8MPX90
-8	12	1/2	3/8" - 18 NPTF	64.7	27.2	48.0	22.2	8G6MPX90
-8	12	1/2	1/2" - 14 NPTF	64.7	27.2	52.3	25.4	8G8MPX90
-12	20	3/4	3/4" - 14 NPTF	80.7	29.7	58.4	34.9	12G12MPX90

Note: Not to be used as a live swivel.

Unless otherwise stated the coupling meets the pressure rating requirements of the respective international standard.

COUPLINGS FOR WIRE AND TEXTILE BRAIDED HOSES MEGACRIMP®

THE WORLD OF COUPLINGS

UNF MB

Male SAE 'O' ring boss. SAE J1926/3.
ISO 11926/3 light duty (L series).

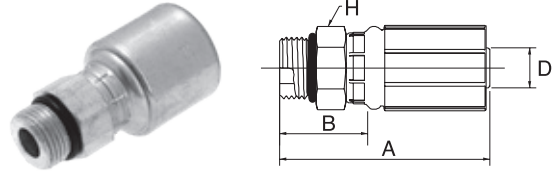

↔			🌀	↔			📏
D				A	B	H	REF.
-size	DN	"		mm	mm	mm	G
-4	6	1/4	7/16" - 20 UNF	50.5	24.5	14.3	4G4MB
-4	6	1/4	1/2" - 20 UNF	50.5	24.5	15.9	4G5MB
-4	6	1/4	9/16" - 18 UNF	52.0	26.0	17.5	4G6MB
-6	10	3/8	9/16" - 18 UNF	56.0	28.1	17.5	6G6MB
-6	10	3/8	3/4" - 16 UNF	58.0	30.1	22.2	6G8MB
-6	10	3/8	7/8" - 14 UNF	56.5	28.6	25.4	6G10MB
-6	10	3/8	1.1/16" - 12 UN	61.5	33.6	31.8	6G12MB
-8	12	1/2	3/4" - 16 UNF	67.0	29.5	22.2	8G8MB
-8	12	1/2	7/8" - 14 UNF	68.0	30.5	25.4	8G10MB
-8	12	1/2	1.1/16" - 12 UN	74.0	36.5	31.8	8G12MB
-10	16	5/8	3/4" - 16 UNF	72.0	34.5	23.8	10G8MB
-10	16	5/8	7/8" - 14 UNF	72.0	34.5	25.4	10G10MB
-10	16	5/8	1.1/16" - 12 UN	76.0	38.5	31.8	10G12MB
-12	20	3/4	1.1/16" - 12 UN	84.5	33.5	31.8	12G12MB
-12	20	3/4	1.3/16" - 12 UN	84.0	33.0	34.9	12G14MB
-12	20	3/4	1.5/16" - 12 UN	87.5	36.5	38.1	12G16MB
-16	25	1	1.3/16" - 12 UN	96.0	39.2	34.9	16G14MB
-16	25	1	1.5/16" - 12 UN	97.5	40.7	38.1	16G16MB
-20	32	1.1/4	1.5/8" - 12 UN	99.0	40.0	47.6	20G20MB

UNF MBX

Male SAE 'O' ring boss swivel.
SAE J1926/3. ISO 11926/3 light duty (L series).

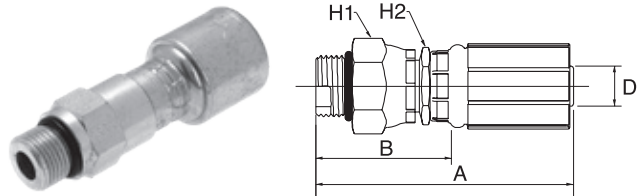

↔			🌀	↔				📏
D				A	B	H1	H2	REF.
-size	DN	"		mm	mm	mm	mm	G
-4	6	1/4	9/16" - 18 UNF	81.5	55.5	19.0		4G6MBX
-6	10	3/8	9/16" - 18 UNF	84.5	56.6	22.0		6G6MBX
-6	10	3/8	3/4" - 16 UNF	84.5	56.6	24.0		6G8MBX
-6	10	3/8	7/8" - 14 UNF	81.5	53.6	27.0		6G10MBX
-8	12	1/2	3/4" - 16 UNF	96.0	58.5	24.0		8G8MBX
-8	12	1/2	7/8" - 14 UNF	97.5	60.0	27.0		8G10MBX
-12	20	3/4	1.1/16" - 12 UN	115.5	64.5	32.0		12G12MBX

Note: Not to be used as a live swivel.

Unless otherwise stated the coupling meets the pressure rating requirements of the respective international standard.

COUPLINGS FOR WIRE AND TEXTILE BRAIDED HOSES MEGACRIMP®

UNF MBX45

Male SAE 'O' ring boss swivel.
SAE J1926/3. ISO 11926/3 light duty (L series).
45° block elbow.

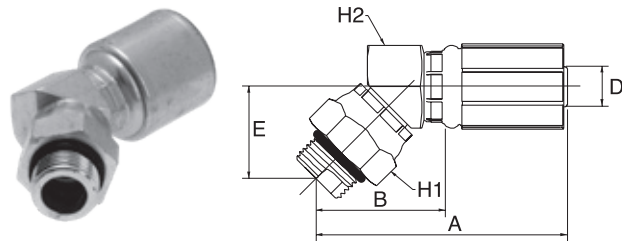

↔			🌀	↔	↔				📐
D				A	B	E	H1	H2	REF.
-size	DN	"		mm	mm	mm	mm	mm	G
-6	10	3/8	9/16" - 18 UNF	79.0	51.0	27.8	22.2	19.1	6G6MBX45
-6	10	3/8	3/4" - 16 UNF	78.1	50.2	26.9	25.4	19.1	6G8MBX45
-8	12	1/2	3/4" - 16 UNF	77.2	39.7	28.4	25.4	25.4	8G8MBX45

Note: Internal seal rings are NBR material. Coupling cannot be swivelled under pressure. Not to be used as a live swivel.

UNF MBX90

Male SAE 'O' ring boss swivel.
SAE J1926/3. ISO 11926/3 light duty (L series).
90° block elbow.

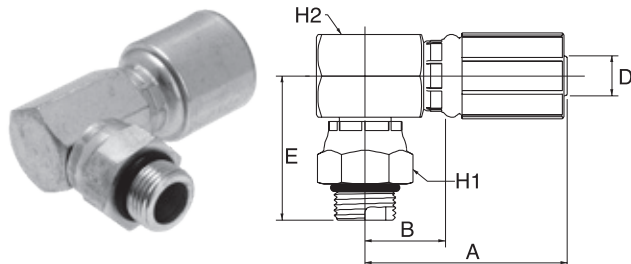

↔			🌀	↔	↔				📐
D				A	B	E	H1	H2	REF.
-size	DN	"		mm	mm	mm	mm	mm	G
-4	6	1/4	9/16" - 18 UNF	46.3	20.2	41.7	22.2	17.5	4G6MBX90
-6	10	3/8	9/16" - 18 UNF	62.8	34.8	63.1	22.0		6G6MBX90
-6	10	3/8	3/4" - 16 UNF	49.7	21.7	41.3	25.4	19.1	6G8MBX90
-6	10	3/8	7/8" - 14 UNF	49.7	21.7	42.8	25.4	19.1	6G10MBX90
-8	12	1/2	3/4" - 16 UNF	64.7	27.2	31.7	25.4	25.4	8G8MBX90
-8	12	1/2	7/8" - 14 UNF	80.3	42.9	71.6	27.0		8G10MBX90
-8	12	1/2	1.1/16" - 12 UN	80.3	42.9	73.6	32.0		8G12MBX90
-10	16	5/8	7/8" - 14 UNF	60.9	23.4	39.6	25.4	25.4	10G10MBX90
-12	20	3/4	1.1/16" - 12 UN	110.1	59.1	86.8	32.0		12G12MBX90

Note: Internal seal rings are NBR material. Coupling cannot be swivelled under pressure. Not to be used as a live swivel.

Unless otherwise stated the coupling meets the pressure rating requirements of the respective international standard.

COUPLINGS FOR WIRE AND TEXTILE BRAIDED HOSES MEGACRIMP®

THE WORLD OF COUPLINGS

FG FFGX

Female French Gaz swivel. 24° cone.

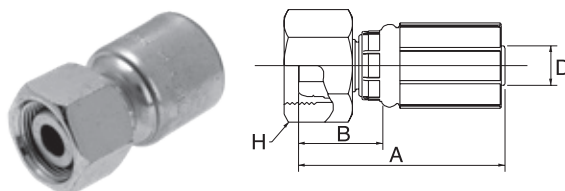

↔			🌀	↔			🌀
D				A	B	H	REF.
-size	DN	"		mm	mm	mm	G
-4	6	1/4	M20 x 1.5	47.0	21.0	24.0	4G13FFGX
-5	8	5/16	M20 x 1.5	51.6	23.6	24.0	5G13FFGX
-6	10	3/8	M20 x 1.5	49.0	21.1	24.0	6G13FFGX
-8	12	1/2	M24 x 1.5	61.0	23.5	30.0	8G17FFGX
-10	16	5/8	M30 x 1.5	59.5	22.0	36.0	10G21FFGX
-12	20	3/4	M36 x 1.5	74.0	23.0	46.0	12G27FFGX
-16	25	1	M45 x 1.5	83.0	26.2	55.0	16G34FFGX
-20	32	1.1/4	M52 x 1.5	85.5	26.5	60.0	20G42FFGX

FG FFGX45

Female French Gaz flare swivel.
24° cone. 45° swept elbow.

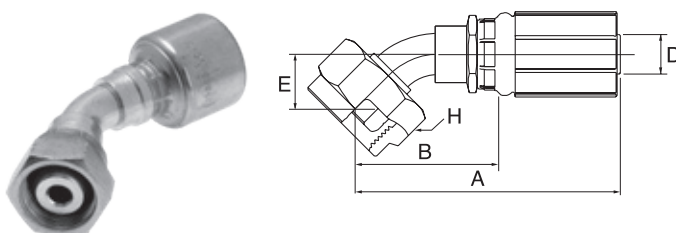

↔			🌀	↔			🌀	
D				A	B	E	H	REF.
-size	DN	"		mm	mm	mm	mm	G
-6	10	3/8	M20 x 1.5	78.1	50.2	25.2	24.0	6G13FFGX45

Unless otherwise stated the coupling meets the pressure rating requirements of the respective international standard.

COUPLINGS FOR WIRE AND TEXTILE BRAIDED HOSES MEGACRIMP®

FG FFGX90

Female French Gaz swivel.
24° cone. 90° swept elbow.

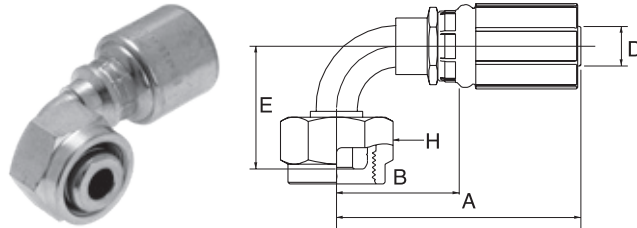

D			M	A B E H				REF. G
-size	DN	"		mm	mm	mm	mm	
-5	8	5/16	M20 x 1.5	64.1	36.1	46.7	24.0	5G13FFGX90
-6	10	3/8	M20 x 1.5	64.1	36.2	46.7	24.0	6G13FFGX90
-8	12	1/2	M24 x 1.5	74.3	36.9	37.8	30.0	8G17FFGX90
-10	16	5/8	M30 x 1.5	79.0	41.6	45.0	36.0	10G21FFGX90
-12	20	3/4	M30 x 1.5	109.6	58.6	71.2	46.0	12G27FFGX90

FG MFG

Male French Gaz parallel. 24° inverted cone.

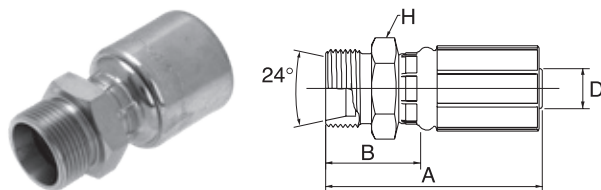

D			M	A B H			REF. G
-size	DN	"		mm	mm	mm	
-5	8	5/16	M20 x 1.5	54.6	26.6	24.0	5G13MFG
-6	10	3/8	M20 x 1.5	54.4	26.5	24.0	6G13MFG
-8	12	1/2	M24 x 1.5	66.5	29.0	27.0	8G17MFG
-10	16	5/8	M30 x 1.5	70.0	32.5	32.0	10G21MFG
-12	20	3/4	M36 x 1.5	84.0	33.0	41.0	12G27MFG
-16	25	1	M45 x 1.5	94.0	37.2	46.0	16G34MFG
-20	32	1.1/4	M52 x 1.5	100.0	41.0	55.0	20G42MFG

Unless otherwise stated the coupling meets the pressure rating requirements of the respective international standard.

COUPLINGS FOR WIRE AND TEXTILE BRAIDED HOSES MEGACRIMP®

THE WORLD OF COUPLINGS

PL

Male Press-Lok stem.

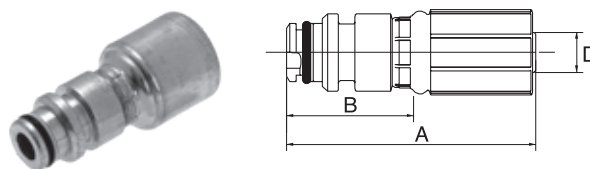

↔			↔		🌀
D			A	B	REF.
-size	DN	"	mm	mm	G
-4	6	1/4	65.0	39.0	4G4PL
-6	10	3/8	67.0	39.1	6G6PL
-8	12	1/2	76.5	39.0	8G8PL
-12	20	3/4	90.5	39.5	12G12PL

Note: 4G4PL: 40 MPa dynamic working pressure; 6G6PL: 30 MPa dynamic working pressure; 8G8PL: 27.5 MPa dynamic working pressure; 12G12PL: 21.5 MPa dynamic working pressure.

AV

Male agricultural valve.

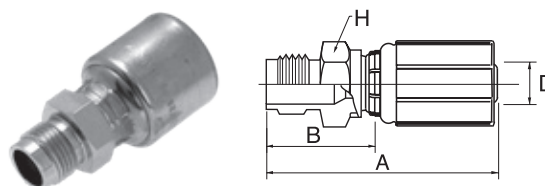

↔			🌀	↔			🌀
D			A	B	H	REF.	
-size	DN	"	mm	mm	mm	G	
-5	8	5/16	M18 x 1.5	59.5	31.5	22.0	5G18AV
-6	10	3/8	M18 x 1.5	59.0	31.1	22.0	6G18AV
-8	12	1/2	M18 x 1.5	68.5	31.0	22.0	8G18AV





Unless otherwise stated the coupling meets the pressure rating requirements of the respective international standard.

COUPLINGS FOR WIRE AND TEXTILE BRAIDED HOSES MEGACRIMP®

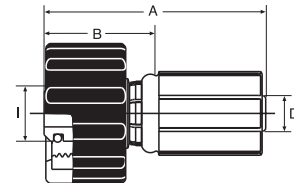
POWERWASH FPWX

Female PowerWash swivel.





							
D				A	B	I	REF.
-size	DN	"		mm	mm	mm	G
-4	6	1/4	M22 x 1.5	54.0	28.0	13.9	4G15FPWX
-5	8	5/16	M22 x 1.5	55.5	27.5	13.9	5G15FPWX
-6	10	3/8	M22 x 1.5	55.5	27.6	13.9	6G15FPWX

POWERWASH PWSP

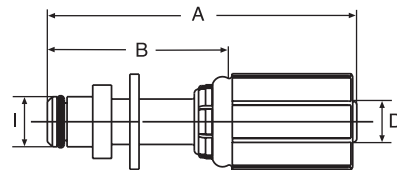
Male PowerWash standpipe with 'O' ring.



						
D			A	B	I	REF.
-size	DN	"	mm	mm	mm	G
-4	6	1/4	60.5	34.5	9.9	4G10PWSP
-5	8	5/16	64.5	36.5	9.9	5G10PWSP
-5	8	5/16	67.5	39.5	10.9	5G11PWSP
-6	10	3/8	64.5	36.6	9.9	6G10PWSP
-6	10	3/8	67.5	39.6	10.9	6G11PWSP

Unless otherwise stated the coupling meets the pressure rating requirements of the respective international standard.

COUPLINGS FOR WIRE AND TEXTILE BRAIDED HOSES MEGACRIMP®

THE WORLD OF COUPLINGS

MLQH

Male Quick-Lok™ High.

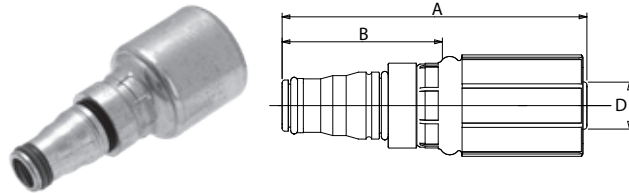

↔			QLH	↔		
D				A	B	REF.
-size	DN	"		mm	mm	G
-04	6	1/4	4MLQH	67.0	41.0	4G4MLQH
-06	10	3/8	6MLQH	69.0	41.1	6G6MLQH
-08	12	1/2	8MLQH	79.0	41.5	8G8MLQH
-10	16	5/8	10MLQH	79.0	41.5	10G10MLQH
-12	20	3/4	12MLQH	93.0	42.0	12G12MLQH
-16	25	1	16MLQH	101.0	44.2	16G16MLQH

-4 to -8 size are 35.0 MPa (5000 psi); -10 & -12 size are 28.0 MPa (4000 psi); -16 size is 21.0 MPa (3000 psi). / Note: not to be used as a live swivel.

MLQH45

Male Quick-Lok™ High.
45° swept elbow.

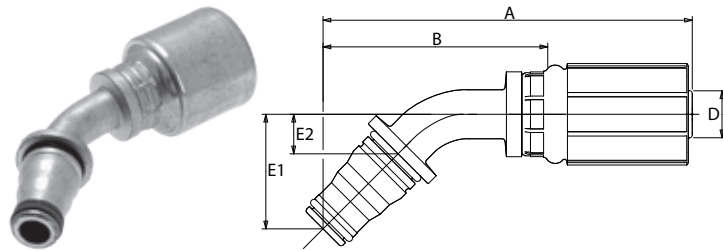

↔			QLH	↔				
D				A	B	E1	E2	REF.
-size	DN	"		mm	mm	mm	mm	G
-04	6	1/4	4MLQH45	75.1	49.1	26.9	7.5	4G4MLQH45
-06	10	3/8	6MLQH45	81.6	53.7	27.7	8.3	6G6MLQH45
-08	12	1/2	8MLQH45	95.7	58.2	29.7	10.3	8G8MLQH45
-10	16	5/8	10MLQH45	104.6	67.1	32.1	12.7	10G10MLQH45
-12	20	3/4	12MLQH45	124.0	73.0	33.6	14.2	12G12MLQH45
-16	25	1	16MLQH45	139.5	82.7	36.1	16.7	16G16MLQH45

-4 to -8 size are 35.0 MPa (5000 psi); -10 & -12 size are 28.0 MPa (4000 psi); -16 size is 21.0 MPa (3000 psi). / Note: not to be used as a live swivel.

Unless otherwise stated the coupling meets the pressure rating requirements of the respective international standard.

COUPLINGS FOR WIRE AND TEXTILE BRAIDED HOSES MEGACRIMP®

MQLH90

Male Quick-Lok™ High.
90° swept elbow.

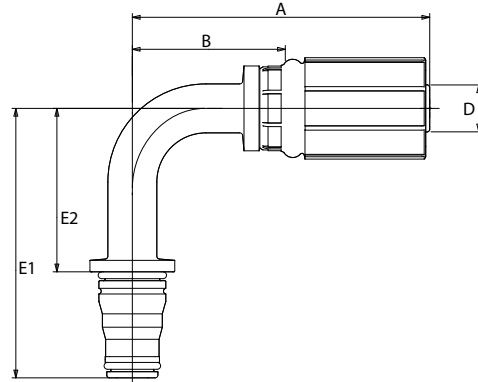

↔			QLH	↔				
D				A	B	E1	E2	REF.
-size	DN	"		mm	mm	mm	mm	G
-04	6	1/4	4MQLH90S	55.6	29.6	45.5	18.0	4G4MQLH90S
-06	10	3/8	6MQLH90S	62.8	34.8	47.6	20.1	6G6MQLH90S
-08	12	1/2	8MQLH90S	80.3	42.9	53.1	25.6	8G8MQLH90S
-10	16	5/8	10MQLH90S	90.1	52.6	60.3	32.8	10G10MQLH90S
-12	20	3/4	12MQLH90S	110.1	59.1	64.3	36.8	12G12MQLH90S
-16	25	1	16MQLH90S	139.1	82.3	71.3	43.8	16G16MQLH90S

-4 to -8 size are 35.0 MPa (5000 psi); -10 & -12 size are 28.0 MPa (4000 psi); -16 size is 21.0 MPa (3000 psi). / Note: not to be used as a live swivel.

FQLH

Female Quick-Lok™ High.

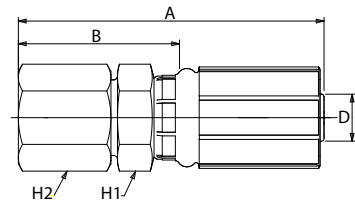

↔			QLH	↔				
D				A	B	H1	H2	REF.
-size	DN	"		mm	mm	mm	mm	G
-04	6	1/4	4FQLH	67.7	41.7	19.1	19.0	4G4FQLH
-06	10	3/8	6FQLH	69.7	41.8	22.0	22.0	6G6FQLH
-08	12	1/2	8FQLH	79.2	41.8	24.0	24.0	8G8FQLH
-10	16	5/8	10FQLH	80.3	42.8	27.0	30.0	10G10FQLH
-12	20	3/4	12FQLH	89.7	38.7	32.0	36.0	12G12FQLH
-16	25	1	16FQLH	101.7	44.9	41.0	41.0	16G16FQLH

-4 to -8 size are 35.0 MPa (5000 psi); -10 & -12 size are 28.0 MPa (4000 psi); -16 size is 21.0 MPa (3000 psi). / Note: not to be used as a live swivel.

Unless otherwise stated the coupling meets the pressure rating requirements of the respective international standard.

THE WORLD OF COUPLINGS
INTEGRATED FLUID POWER SOLUTIONS



COUPLINGS FOR WIRE SPIRAL BLASTING HOSES

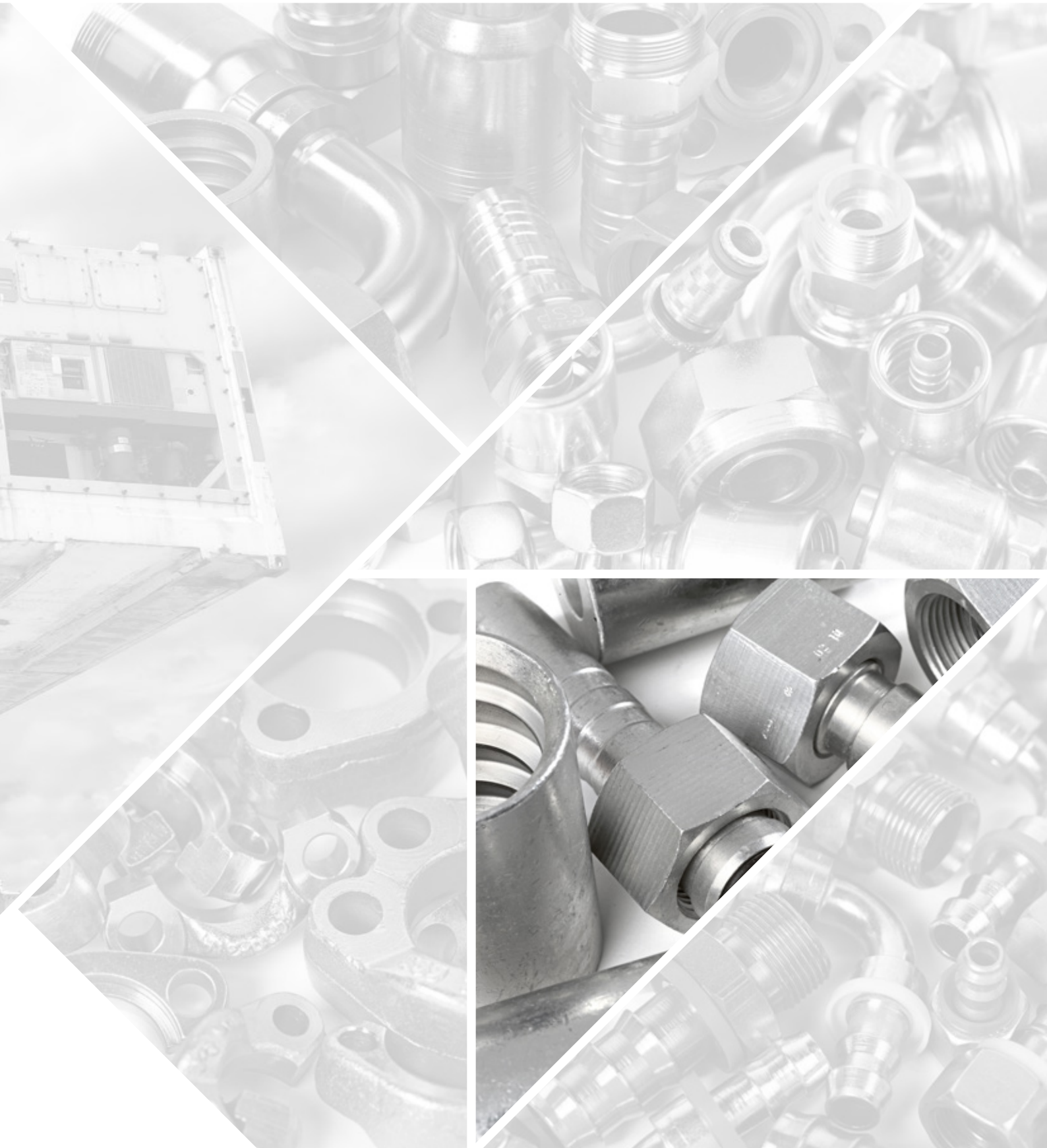

COUPLINGS FOR WIRE SPIRAL BLASTING HOSES WATERBLAST

THE WORLD OF COUPLINGS

SKIVE FERRULES

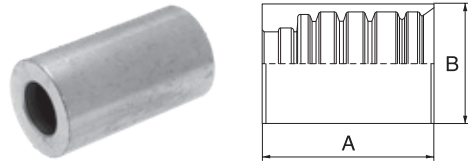

D			A	B	REF.
-size	DN	"	mm	mm	WTB
-6	10	3/8	45.0	28.0	6WTB2F-4
-8	12	1/2"	60.0	33.0	8WTB2F-4
-12	20	3/4"	66.0	46.0	12WTB2F-1

BSP FBSPORX

Female BSP 'O' ring swivel. 60° cone.

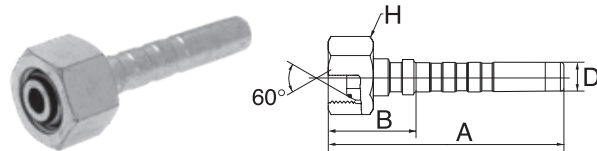

D			A	B	H	REF.	
-size	DN	"	mm	mm	mm	WTB	
-6	10	3/8	73.8	23.8	22.2	6WTB6FBSPORX-SP	
-8	12	1/2"	88.7	23.7	29.0	8WTB8FBSPORX-SP	
-12	20	3/4"	103.0	29.0	34.0	12WTB12FBSPORX-SP	

Unless otherwise stated the coupling meets the pressure rating requirements of the respective international standard.

COUPLINGS FOR WIRE SPIRAL BLASTING HOSES WATERBLAST

DIN 24° FDHORX

Female DIN 'O' ring swivel. 24° cone.
Heavy series.

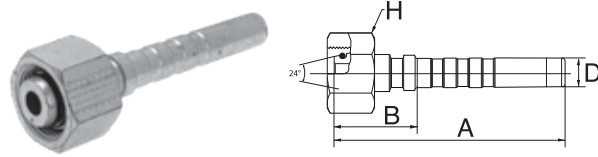

↔			🌀	↔	🌀		
D				A	B	H	REF.
-size	DN	"		mm	mm	mm	WTB
-6	10	3/8	M22 x 1.5	85.0	35.0	27.0	6WTB14FDHORX
-8	12	1/2	M24 x 1.5	101.8	36.8	30.0	8WTB16FDHORX
-12	20	3/4	M36 x 2.0	121.5	47.5	46.0	12WTB25FDHORX

NPTF MP

Male NPTF pipe.

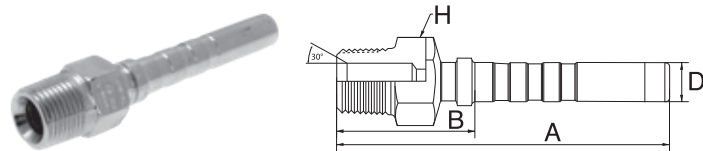

↔			🌀	↔	🌀		
D				A	B	H	REF.
-size	DN	"		mm	mm	mm	WTB
-6	10	3/8	3/8" - 18 NPTF	89.6	39.6	19.0	6WTB6MP
-8	12	1/2	1/2" - 14 NPTF	109.6	44.6	22.0	8WTB8MP
-12	20	3/4	3/4" - 14 NPTF	120.5	46.5	27.0	12WTB12MP

Unless otherwise stated the coupling meets the pressure rating requirements of the respective international standard.

THE WORLD OF COUPLINGS
INTEGRATED FLUID POWER SOLUTIONS



COUPLINGS FOR PUSH-ON TEXTILE HOSES

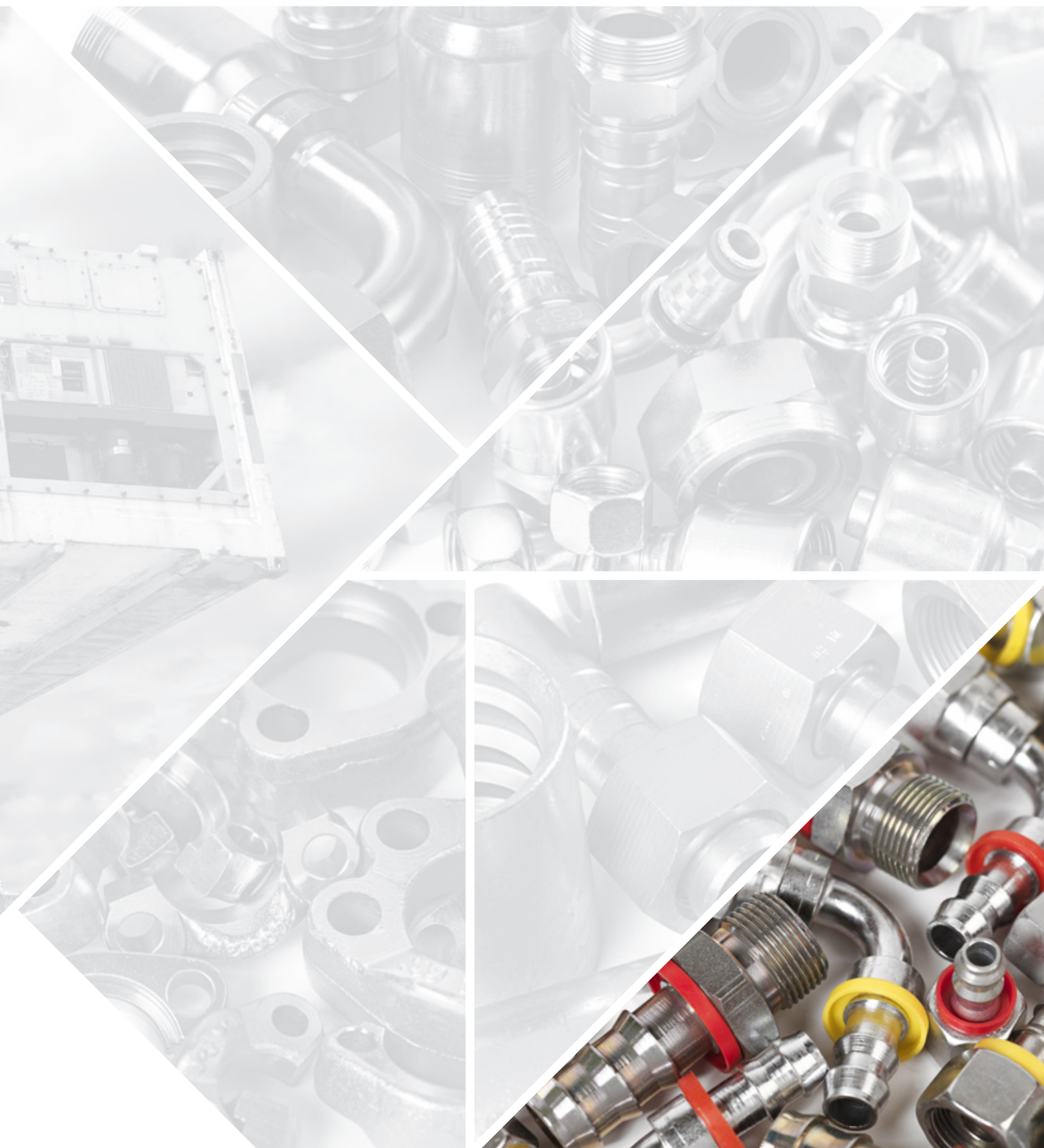

COUPLINGS FOR PUSH-ON TEXTILE HOSES LOCK-ON

THE WORLD OF COUPLINGS

BSP FBSPPX

Female BSP swivel. 60° cone (Ball Nose).

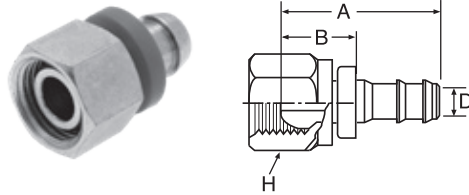

D				A B H			REF.
-size	DN	"		mm	mm	mm	LOC
-4	6	1/4	1/4" - 19 BSP	29.5	9.0	15.2	4LOC4FBSPPX
-6	10	3/8	3/8" - 19 BSP	32.4	9.0	20.8	6LOC6FBSPPX
-8	13	1/2	1/2" - 14 BSP	37.6	10.0	23.4	8LOC8FBSPPX
-12	19	3/4	3/4" - 14 BSP	60.2	14.0	33.0	12LOC12FBSPPX

BSP FBSPPX90

Female BSP swivel. 60° cone (Ball Nose).
90° swept elbow.

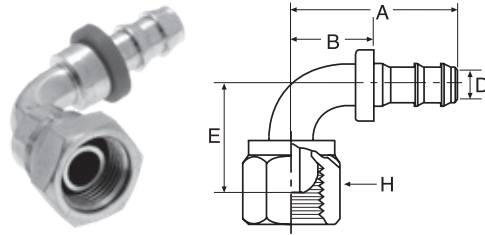

D				A B E H				REF.
-size	DN	"		mm	mm	mm	mm	LOC
-4	6	1/4	1/4" - 19 BSP	42.9	21.6	31.1	18.0	4LOC4FBSPPX90
-6	10	3/8	3/8" - 19 BSP	51.8	27.0	39.1	20.8	6LOC6FBSPPX90
-8	13	1/2	1/2" - 14 BSP	63.0	33.6	44.5	25.7	8LOC8FBSPPX90
-12	19	3/4	3/4" - 14 BSP	87.5	44.5	54.4	33.0	12LOC12FBSPPX90

Unless otherwise stated the coupling meets the pressure rating requirements of the respective international standard.

COUPLINGS FOR PUSH-ON TEXTILE HOSES LOCK-ON

BSP MBSPP

Male BSP parallel. 60° inverted cone.

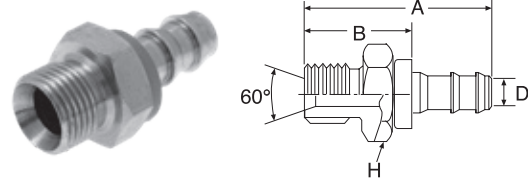

↔			🌀	↔	🌀		
D				A	B	H	REF.
-size	DN	"		mm	mm	mm	LOC
-4	6	1/4	1/4" - 19 BSP	41.1	20.0	18.0	4LOC4MBSPP
-6	10	3/8	1/4" - 19 BSP	40.0	19.0	19.0	6LOC4MBSPP
-6	10	3/8	3/8" - 19 BSP	46.9	22.5	23.4	6LOC6MBSPP
-8	13	1/2	1/2" - 14 BSP	55.5	26.1	25.7	8LOC8MBSPP
-12	19	3/4	3/4" - 14 BSP	73.7	30.5	33.0	12LOC12MBSPP

JIC 37° FJX

Female JIC swivel. 37° inverted cone.

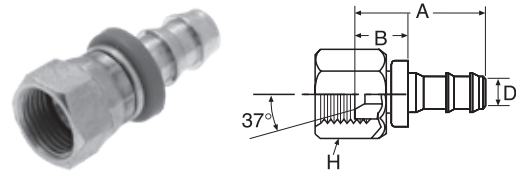

↔			🌀	↔	🌀		
D				A	B	H	REF.
-size	DN	"		mm	mm	mm	LOC
-4	6	1/4	7/16" - 20 UNF	33.1	11.8	14.2	4LOC4FJX
-6	10	3/8	9/16" - 18 UNF	37.8	13.0	17.4	6LOC6FJX
-8	13	1/2	3/4" - 16 UNF	44.9	16.3	22.3	8LOC8FJX
-10	16	5/8	7/8" - 14 UNF	58.3	17.5	25.7	10LOC10FJX
-12	19	3/4	1.1/16" - 12 UN	61.7	18.5	31.8	12LOC12FJX

Unless otherwise stated the coupling meets the pressure rating requirements of the respective international standard.

COUPLINGS FOR PUSH-ON TEXTILE HOSES LOCK-ON

THE WORLD OF COUPLINGS

DIN 24° / 60° FDLX

Female DIN swivel. 24°/60° cone.
Light series.

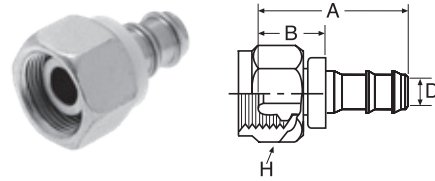

↔			🌀	↔			🌀
D				A	B	H	REF.
-size	DN	"		mm	mm	mm	LOC
-4	6	1/4	M12 x 1.5	37.5	19.5	17.0	4LOC6FDLX
-4	6	1/4	M14 x 1.5	33.5	12.0	17.0	4LOC8FDLX
-6	10	3/8	M16 x 1.5	37.5	12.0	19.0	6LOC10FDLX
-6	10	3/8	M18 x 1.5	37.5	12.0	22.0	6LOC12FDLX
-8	12	1/2	M22 x 1.5	43.8	15.1	27.0	8LOC15FDLX
-10	16	5/8	M26 x 1.5	57.3	13.8	32.0	10LOC18FDLX
-12	20	3/4	M30 x 2.0	59.4	14.0	36.0	12LOC22FDLX

DIN 24° / 60° FDLX90

Female DIN swivel. 24°/60° cone.
Light series. 90° swept elbow.

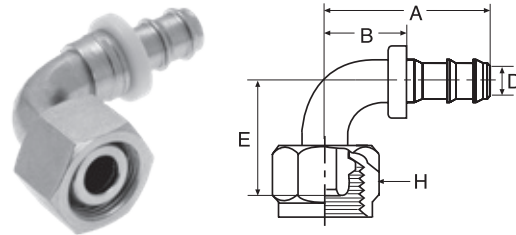

↔			🌀	↔			🌀	
D				A	B	E	H	REF.
-size	DN	"		mm	mm	mm	mm	LOC
-4	6	1/4	M12 x 1.5	39.1	21.1	30.5	14.0	4LOC6FDLX90
-4	6	1/4	M14 x 1.5	42.1	24.1	33.5	17.0	4LOC8FDLX90
-6	10	3/8	M16 x 1.5	48.1	27.1	39.5	19.0	6LOC10FDLX90
-6	10	3/8	M18 x 1.5	51.9	30.9	42.5	22.0	6LOC12FDLX90
-8	12	1/2	M22 x 1.5	60.7	37.0	44.9	27.0	8LOC15FDLX90
-10	16	5/8	M26 x 1.5	79.2	41.0	51.4	32.0	10LOC18FDLX90
-12	20	3/4	M30 x 2.0	88.2	49.8	57.4	36.0	12LOC22FDLX90

Unless otherwise stated the coupling meets the pressure rating requirements of the respective international standard.

COUPLINGS FOR PUSH-ON TEXTILE HOSES LOCK-ON

METRIC MSP

Metric standpipe.

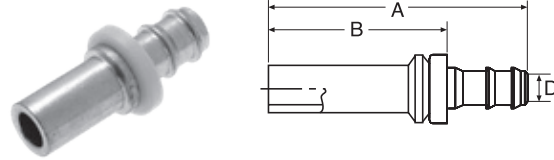

↔			↔		🔧
D			A	B	REF.
-size	DN	"	mm	mm	LOC
-4	6	1/4	47.0	29.0	4LOC8MSP
-6	10	3/8	51.0	30.0	6LOC10MSP
-6	10	3/8	51.0	30.0	6LOC12MSP
-8	12	1/2	54.8	31.1	8LOC15MSP
-10	16	5/8	68.3	30.0	10LOC18MSP
-12	20	3/4	70.4	32.0	12LOC22MSP

METRIC DBJ

Metric banjo.

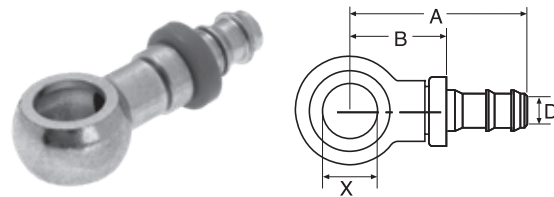

↔			🔧	↔			🔧
D			A	B	X	REF.	
-size	DN	"	mm	mm	mm	G	
-4	6	1/4	M10	42.5	24.5	10.1	4LOC10DBJ
-6	10	3/8	M14	49.5	28.5	14.1	6LOC14DBJ

NPTF MP

Male NPTF pipe.

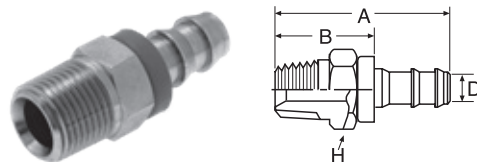

↔			🔧	↔			🔧
D			A	B	H	REF.	
-size	DN	"	mm	mm	mm	LOC	
-4	6	1/4	1/4" - 18 NPTF	45.2	24.0	14.3	4LOC4MP
-6	10	3/8	3/8" - 18 NPTF	48.7	24.0	17.4	6LOC6MP
-8	13	1/2	1/2" - 14 NPTF	58.9	30.5	22.0	8LOC8MP
-12	19	3/4	3/4" - 14 NPTF	73.1	30.0	27.9	12LOC12MP

Unless otherwise stated the coupling meets the pressure rating requirements of the respective international standard.

THE WORLD OF COUPLINGS
INTEGRATED FLUID POWER SOLUTIONS



ACCESSORIES

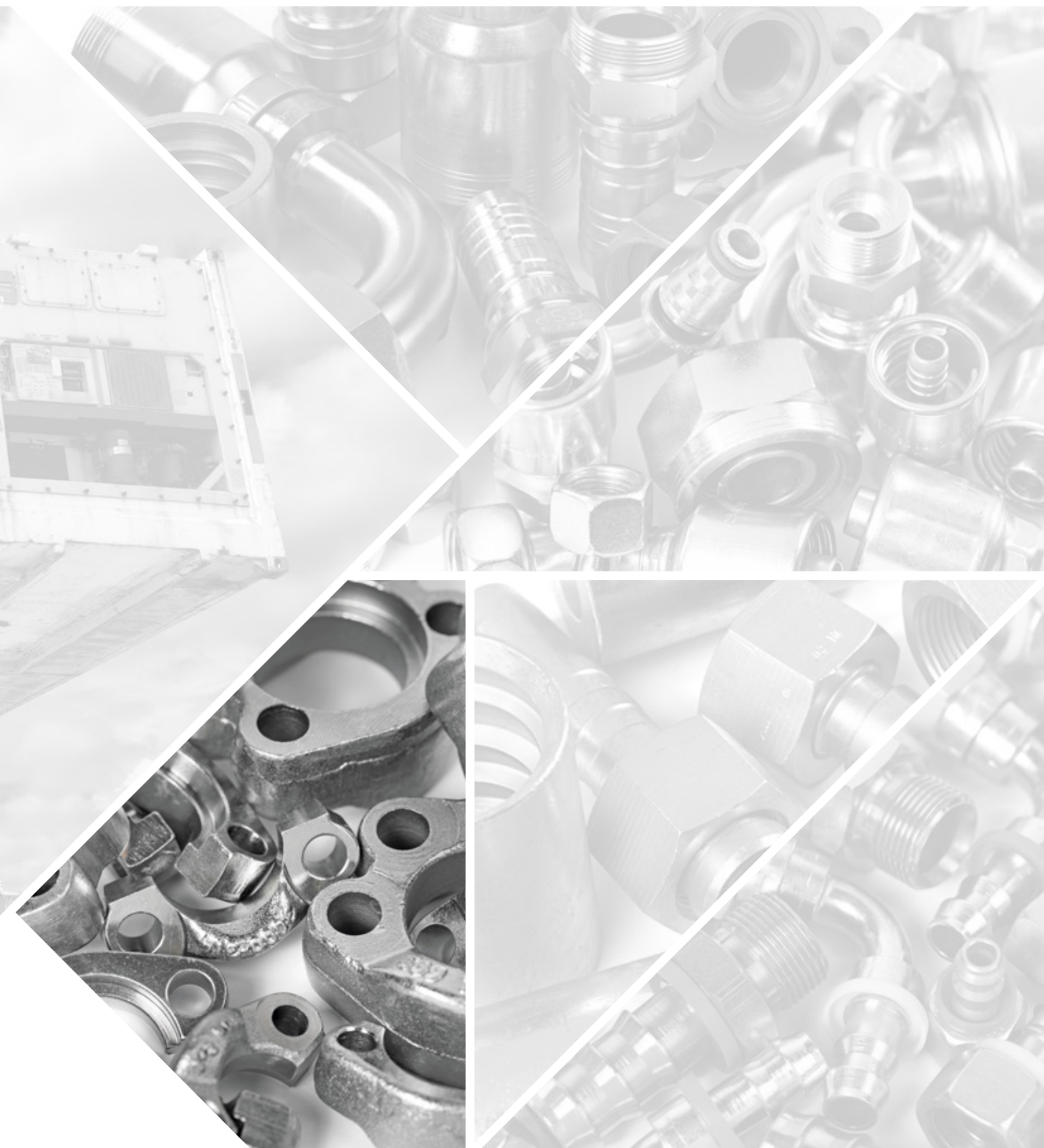

ACCESSORIES FLANGE KITS

THE WORLD OF COUPLINGS

SAE PA-FL FLANGE KIT

SAE flange kit. Code 61. SAE standard pressure.
Each kit comprises:
- 2 flange halves (PA-FL75)
- 4 bolts
- 4 washers
- 'O' ring (PA-FL77)

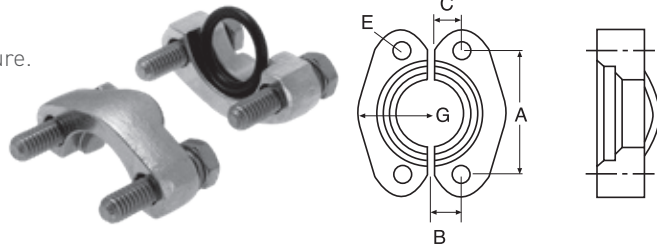

↔			⌚	↔				⌚
D				A	B	D	E	REF.
-size	DN	"		mm	mm	mm	mm	PA-FL
-8	12	1/2	35.0	38.1	8.8	54.0	8.9	8PA-FL
-12	20	3/4	35.0	47.6	11.1	65.1	10.6	12PA-FL
-16	25	1	35.0	52.4	13.1	69.9	10.6	16PA-FL
-20	32	1.1/4	28.0	58.7	15.1	79.4	12.0	20PA-FL
-24	40	1.1/2	21.0	69.9	17.9	93.8	13.3	24PA-FL
-32	50	2	21.0	77.8	21.5	101.6	13.5	32PA-FL

Code 61: -16 size is 35.0 MPa (5000 psi).

SAE PH-FLH FLANGE KIT

SAE flange kit. Code 62. SAE high pressure.
Each kit comprises:
- 2 flange halves (PH-FLH75)
- 4 bolts
- 4 washers
- 'O' ring (PH-FLH77)

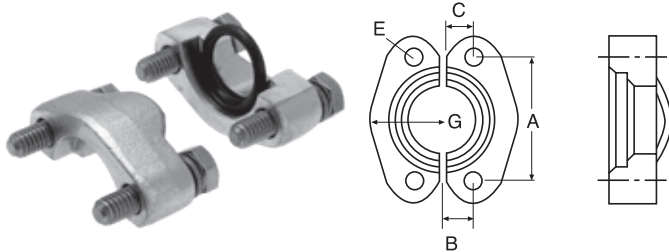

↔			⌚	↔				⌚
D				A	B	D	E	REF.
-size	DN	"		mm	mm	mm	mm	PA-FL
-8	12	1/2	42.0	40.5	9.1	56.4	8.9	8PH-FLH
-12	20	3/4	42.0	50.8	11.9	71.4	10.6	12PH-FLH
-16	25	1	42.0	57.2	13.9	81.1	12.0	16PH-FLH
-20	32	1.1/4	42.0	66.7	15.9	95.3	13.3	20PH-FLH
-24	40	1.1/2	42.0	79.4	18.3	112.8	16.7	24PH-FLH
-32	50	2	42.0	96.8	22.3	133.4	20.6	32PH-FLH

Unless otherwise stated the coupling meets the pressure rating requirements of the respective international standard.

ACCESSORIES FLANGE KITS

SAE PH-FLH MONOBLOC KIT

SAE flange kit. Code 62 (metric). SAE high pressure.

Each kit comprises:

- dual flange
- 4 bolts
- 4 washers
- 'O' ring

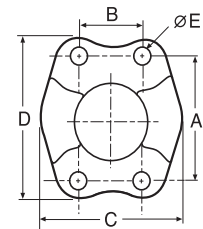

↔			⌚	↔					⌚
D				A	B	C	D	E	REF.
-size	DN	"		mm	mm	mm	mm	mm	PA-FL
-8	13	1/2	40.0	40.5	18.2	47.8	56.4	8.9	8FLHCFM
-12	19	3/4	40.0	50.8	23.8	60.5	71.4	10.6	12FLHCFM
-16	25	1	40.0	57.2	27.8	69.9	81.1	13.3	16FLHCFM
-20	32	1.1/4	40.0	66.7	31.8	77.7	95.3	13.3	20FLHCFM
-24	38	1.1/2	40.0	79.4	36.5	95.3	112.8	16.7	24FLHCFM
-32	51	2	40.0	96.8	44.5	114.3	133.4	20.6	32FLHCFM

Unless otherwise stated the coupling meets the pressure rating requirements of the respective international standard.



INTEGRATED FLUID POWER SOLUTIONS

THE WORLD OF ADAPTORS



GATES HYDRAULIC ADAPTORS

THE WORLD OF ADAPTORS

THE MISSING LINK IN THE HYDRAULIC CIRCUIT

With the addition of the BSP / JIC adaptor range, Gates has taken its Integrated Approach to the next level where hoses, couplings, tube fittings and adaptors are designed together to obtain trustworthy port-to-port solutions.



Your total fluid power solution

The Gates Integrated System Approach offers you complete solutions to your fluid power needs. All our hydraulic products are manufactured to stern tolerances and are specifically designed, tested and validated together. This is why our entire hydraulic product line works together perfectly, ensuring you a leak-free operation. And this is why Gates is the reference in the market.

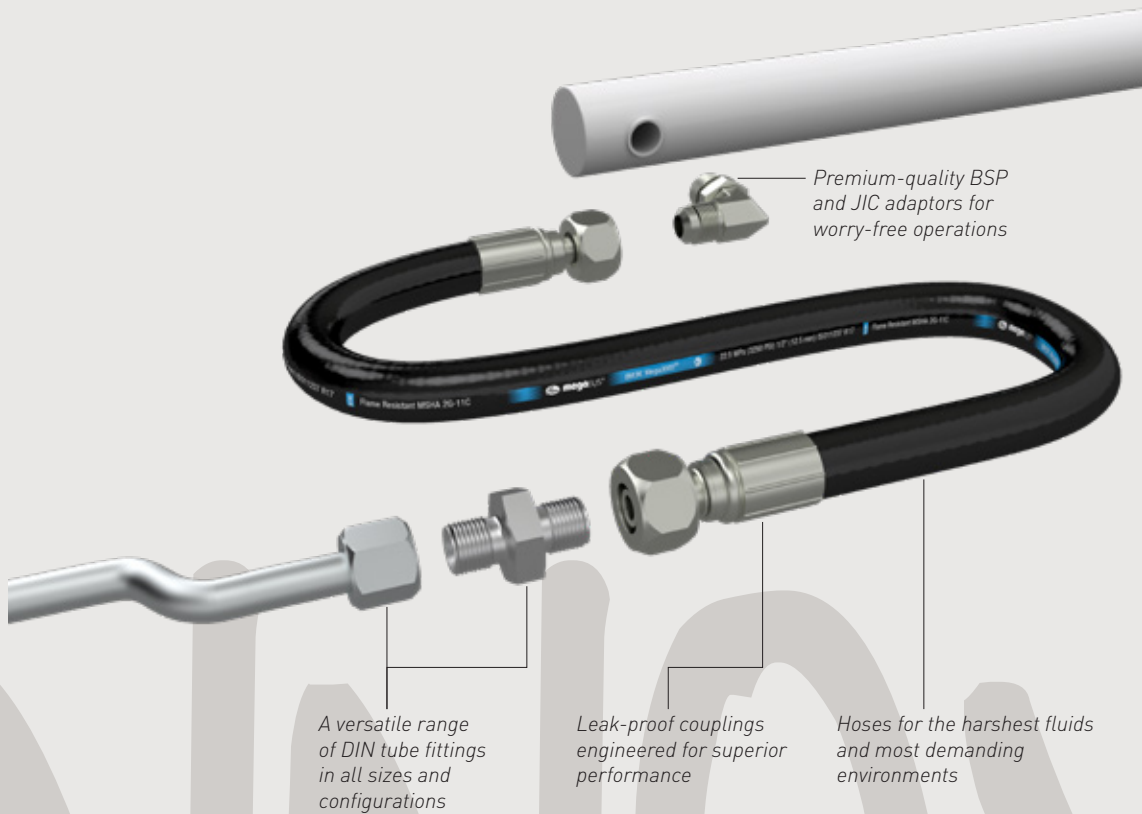

*A hydraulic adaptor range
offering you exceptional reliability*



*With Gates new hydraulic adaptor range,
we now have everything in place to be
your preferred one-stop-shop!*

Trustworthy solutions from port to port

Gates BSP & JIC adaptors complete the hydraulic circuit and from now on, you can rely on trusted Gates quality products to do that job! This versatile and competitively priced product range covers most of the European needs. The program provides you with a well-balanced stock mix that limits your distribution investment but ensures that you always have the right part at hand for an optimal response time to any breakdown which helps you to maximise profit. The adaptors are available in a wide array of sizes and configurations:

- > Jump size adaptors – to reduce or expand the existing thread
- > Thread conversion adaptors – to change from one port thread to another to allow tube fitting or hose connections to be made
- > Hose end adaptors – hose to port, hose to hose, etc.



Ready for the future and the next generation of hydraulic connections. Check out the Gates Quick-Lok™ adaptors – available in the most common international termination types - allowing you to easily change from threaded connections to Quick-Lok™ High couplings.

ATTENTION

ADAPTOR SELECTION TABLE

THE WORLD OF ADAPTORS

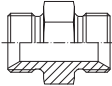
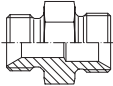
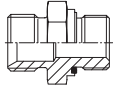
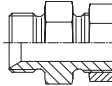
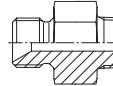
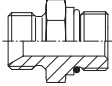
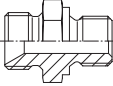
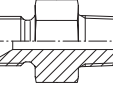
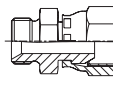
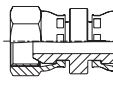
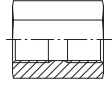
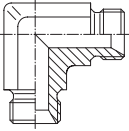
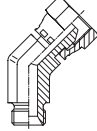
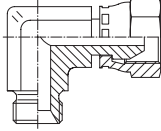
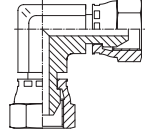
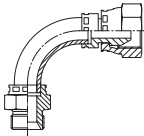
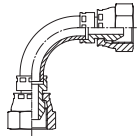
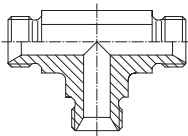
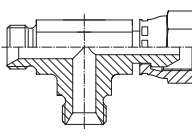
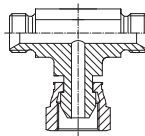
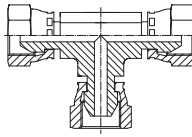
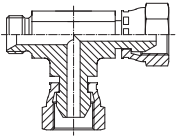
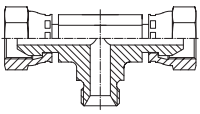
BSP

MBSPP				
				
MBSPP-MBSPP p. 310	MBSPP-MBSPP p. 311	MBSPP-MBSPPWD p. 312	MBSPP-MBSPPBKH p. 313	MBSPP-MBSPT p. 314
MBSPP				FBSPPX
				
MBSPP-MB p. 315	MBSPP-MM p. 316	MBSPP-MP p. 317	MBSPP-FBSPPX p. 318	FBSPPX-FBSPPX p. 319
FBSPPX	MBSPP			FBSPPX
				
FBSPPX-FBSPPX p. 320	MBSPP-MBSPP90BL p. 320	MBSPP-FBSPPX45BL p. 321	MBSPP-FBSPPX90BL p. 321	FBSPPX-FBSPPX90BL p. 322
MBSPP	FBSPPX	MBSPP		
				
MBSPP-FBSPPX90SWT p. 322	FBSPPX-FBSPPX90SWT p. 323	MBSPP-MBSPP-MBSPP p. 323	MBSPP-FBSPPX-MBSPP p. 324	MBSPP-MBSPP-FBSPPX p. 324
FBSPPX	MBSPP	FBSPPX	MBSPP	FBSPPX
				
FBSPPX-FBSPPX-FBSPPX p. 325	MBSPP-FBSPPX-FBSPPX p. 325	FBSPPX-FBSPPX-MBSPP p. 326	MBSPP-PLUG p. 326	FBSPPX-CAP p. 327

JIC

MJ

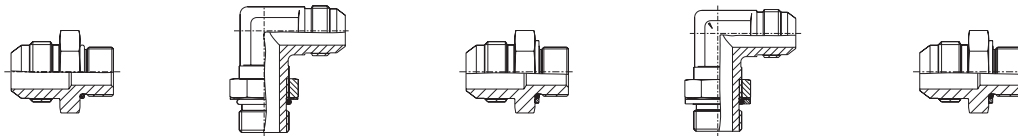

MJ-MMOR
p. 330

MJ-MMAOR90
p. 330

MJ-MMCOR
p. 331

MJ-MMACOR90
p. 331

MJ-MBSPPCOR
p. 332

MJ

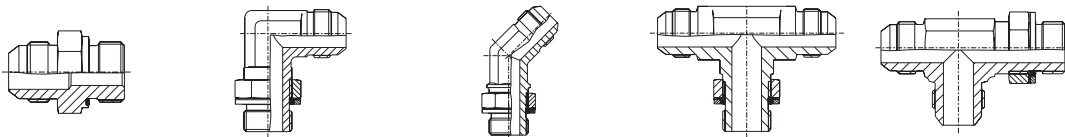

MJ-MBSPPWD
p. 333

MJ-MBSPPACOR90
p. 334

MJ-MBSPPACOR45
p. 335

MJ-MJ-MBSPPACOR
p. 336

MJ-MBSPPACOR-MJ
p. 336

MJ

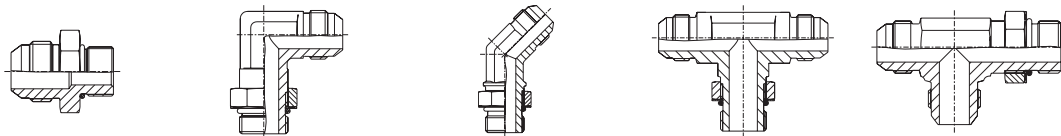

MJ-MB
p. 337

MJ-MBA90
p. 338

MJ-MBA45
p. 338

MJ-MJ-MBA
p. 339

MJ-MBA-MJ
p. 339

MJ

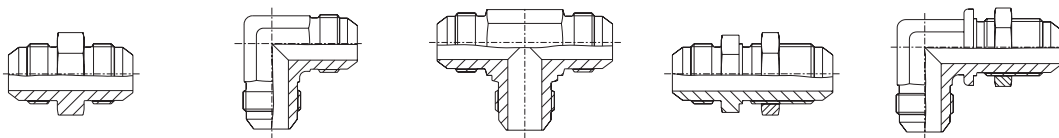

MJ-MJ
p. 340

MJ-MJ90
p. 340

MJ-MJ-MJ
p. 341

MJ-MJBKHD
p. 341

MJ-MJBKHD90
p. 342

MJ

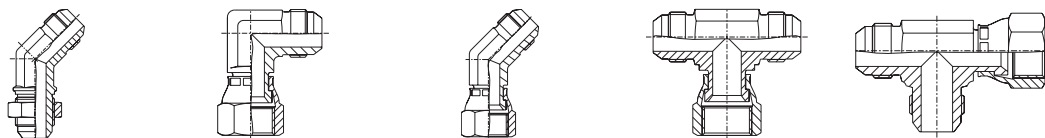

MJ-MJBKHD45
p. 342

MJ-FJX90
p. 343







MJ-FJX45
p. 343

MJ-MJ-FJX
p. 344

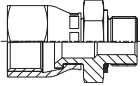
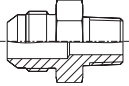
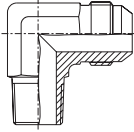
MJ-FJX-MJ
p. 344

ADAPTOR SELECTION TABLE

THE WORLD OF ADAPTORS

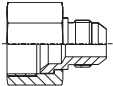
FJX	MJ		FJ	MJ
				
FJX-MBSPPCOR p. 345	MJ-MP p. 346	MJ-MP90 p. 346	FJ-CAP p. 347	MJ-PLUG p. 347
FJ	Metric TS	Imp. TS	FJX	
				
FJ-NUT p. 348	*TS p. 348	TS* p. 349	FJX-MJ p. 349	

QLH

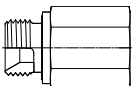
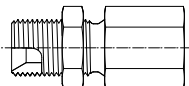
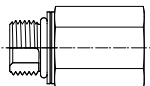
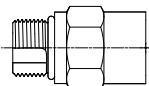
MBSP	MBSPBKHD	MMOR	MB
			
MBSP-FQLH p. 352	MBSPBKHD-FQLH p. 352	MMOR-FQLH p. 353	MB-FQLH p. 353

EXPLANATIONS



THE WORLD OF ADAPTORS

GATES PART NUMBER ABBREVIATIONS

PART NUMBER	DESCRIPTION
MBSPP	Male BSP Parallel
MBSPPBKH	Male BSP Bulkhead
MBSPT	Male BSP Taper
MB	UN/UNF SAE O-Ring
MM	Metric Male
MP	Male NPT
FBSPPX	Female BSPP Swivel
FBSPP	Female BSPP Fixed
MJ	Male JIC
MJBKHD	Male JIC Bulkhead
FJX	Female JIC Swivel
BL	Compact Elbow
SWT	Swept Elbow
OR	O-Ring
COR	O-Ring & Retaining Ring
WD	Captive Seal
A	Adjustable

Dash Size	BSPP	JIC	SAE	NPT
2	1/8-28			Z1/8-27
4	1/4-19	7/16-20	7/16-20	Z1/4-18
5		1/2-20	1/2-20	
6	3/8-19	9/16-18	9/16-18	Z3/8-18
8	1/2-14	3/4-16	3/4-16	Z1/2-14
10	5/8-14	7/8-14	7/8-14	
12	3/4-14	1.1/16-12	1.1/16-12	Z3/4-14
14		1.3/16-12	1.3/16-12	
16	1-11	1.5/16-12	1.5/16-12	Z1-11.5
20	1.1/4-11	1.5/8-12	1.5/8-12	Z1.1/4-11.5
24	1.1/2-11	1.7/8-12	1.7/8-12	Z1.1/2-11.5
32	2-11			Z2-11.5

EXPLANATION OF SYMBOLS

SYMBOLS	DESCRIPTION
	Thread
	Length
	Hex / Flats

EXPLANATION OF ORDERING EXAMPLES

ORDERING EXAMPLE 1:	
6MJ-8MBSPPACOR90	
6	= 9/16-18 UNF
MJ	= Male JIC
8	= 1/2-14
MBSPP	= Male BSP Parallel
A	= Adjustable
COR	= O-Ring & Retaining Ring
90	= 90 Degree Elbow

ORDERING EXAMPLE 2:	
4MBSPP-4FBSPPX-4MBSPP	
4	= 1/4-19
MBSPP	= Male BSP Parallel
4	= 1/4-19
FBSPPX	= Female BSP Swivel
4	= 1/4-19
MBSPP	= Male BSP Parallel*

*[Final part of tee is on branch]

THE WORLD OF ADAPTORS
INTEGRATED FLUID POWER SOLUTIONS



BSP ADAPTORS

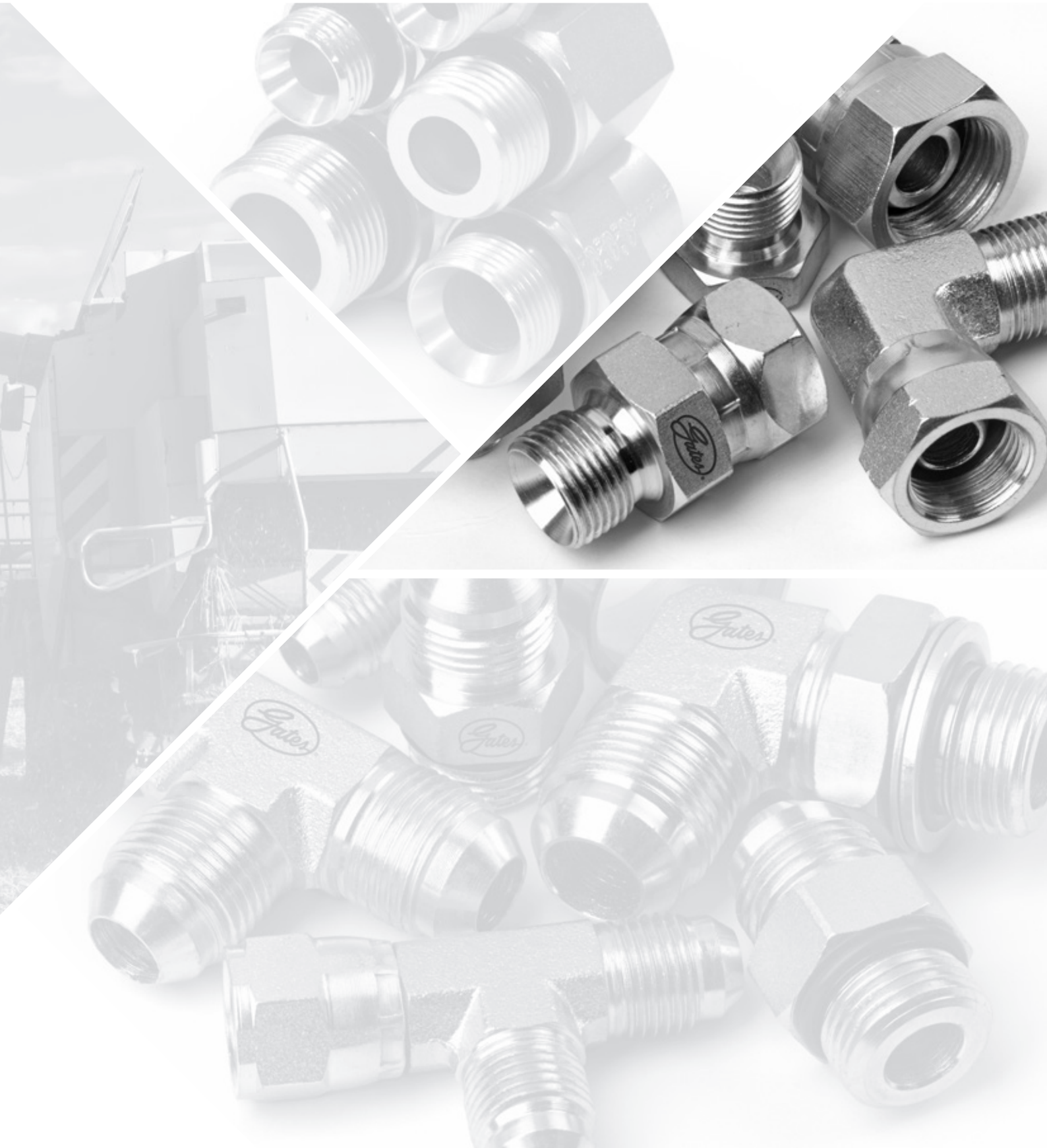

BSP ADAPTORS





BS5200

THE WORLD OF ADAPTORS

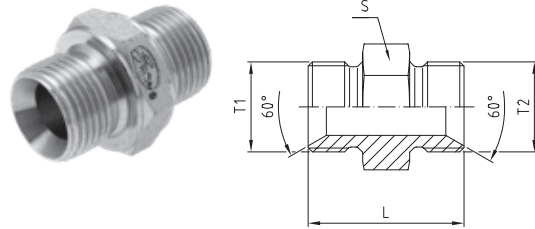
BSP MBSPP-MBSPP EQUAL

BSPP 60° Male / Male equal.



				
ref.	T1	T2	L	S
BSP	BSPP	BSPP	mm	mm
2MBSPP-2MBSPP	1/8-28	1/8-28	26.0	14.0
4MBSPP-4MBSPP	1/4-19	1/4-19	30.0	19.0
6MBSPP-6MBSPP	3/8-19	3/8-19	33.0	22.0
8MBSPP-8MBSPP	1/2-14	1/2-14	42.0	27.0
10MBSPP-10MBSPP	5/8-14	5/8-14	45.0	30.0
12MBSPP-12MBSPP	3/4-14	3/4-14	48.0	32.0
16MBSPP-16MBSPP	1-11	1-11	54.0	41.0
20MBSPP-20MBSPP	1.1/4-11	1.1/4-11	58.0	50.0
24MBSPP-24MBSPP	1.1/2-11	1.1/2-11	63.0	55.0
32MBSPP-32MBSPP	2-11	2-11	68.0	70.0





BSP ADAPTORS

BS5200

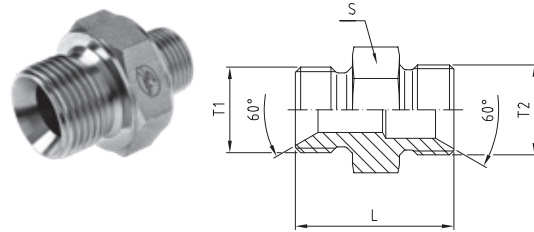
BSP MBSPP-MBSPP UNEQUAL

BSP 60° Male / Male unequal.



			
ref.	T1	T2	L
BSP	BSPP	BSPP	mm
2MBSPP-4MBSPP	1/8-28	1/4-19	28.0
2MBSPP-6MBSPP	1/8-28	3/8-19	31.5
2MBSPP-8MBSPP	1/8-28	1/2-14	36.0
4MBSPP-6MBSPP	1/4-19	3/8-19	33.5
4MBSPP-8MBSPP	1/4-19	1/2-14	38.0
4MBSPP-10MBSPP	1/4-19	5/8-14	39.5
4MBSPP-12MBSPP	1/4-19	3/4-14	41.5
4MBSPP-16MBSPP	1/4-19	1-11	45.5
6MBSPP-8MBSPP	3/8-19	1/2-14	39.5
6MBSPP-10MBSPP	3/8-19	5/8-14	42.0
6MBSPP-12MBSPP	3/8-19	3/4-14	43.0
6MBSPP-16MBSPP	3/8-19	1-11	47.0
8MBSPP-10MBSPP	1/2-14	5/8-14	43.5
8MBSPP-12MBSPP	1/2-14	3/4-14	45.5
8MBSPP-16MBSPP	1/2-14	1-11	50.0
8MBSPP-20MBSPP	1/2-14	1.1/4-11	53.5
10MBSPP-12MBSPP	5/8-14	3/4-14	47.0
10MBSPP-16MBSPP	5/8-14	1-11	51.5
12MBSPP-16MBSPP	3/4-14	1-11	52.5
12MBSPP-20MBSPP	3/4-14	1.1/4-11	56.0
16MBSPP-20MBSPP	1-11	1.1/4-11	58.0
16MBSPP-24MBSPP	1-11	1.1/2-11	60.5
16MBSPP-32MBSPP	1-11	2-11	64.0
20MBSPP-24MBSPP	1.1/4-11	1.1/2-11	60.5
20MBSPP-32MBSPP	1.1/4-11	2-11	64.0
24MBSPP-32MBSPP	1.1/4-11	2-11	66.5

BSP ADAPTORS





BS5200

THE WORLD OF ADAPTORS

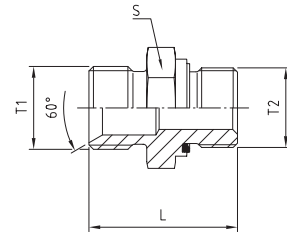
BSP MBSPP-MBSPPWD

BSP 60° Male / Male with captive seal.



				
ref.	T1	T2	L	S
BSP	BSPP	BSPP WD	mm	mm
2MBSPP-2MBSPPWD	1/8-28	1/8-28	25.5	14.0
4MBSPP-2MBSPPWD	1/4-19	1/8-28	27.5	19.0
6MBSPP-2MBSPPWD	3/8-19	1/8-28	29.0	22.0
2MBSPP-4MBSPPWD	1/8-28	1/4-19	30.0	19.0
4MBSPP-4MBSPPWD	1/4-19	1/4-19	32.0	19.0
6MBSPP-4MBSPPWD	3/8-19	1/4-19	33.5	22.0
8MBSPP-4MBSPPWD	1/2-14	1/4-19	40.0	27.0
12MBSPP-4MBSPPWD	3/4-14	1/4-19	41.5	32.0
4MBSPP-6MBSPPWD	1/4-19	3/8-19	34.5	22.0
6MBSPP-6MBSPPWD	3/8-19	3/8-19	34.0	22.0
8MBSPP-6MBSPPWD	1/2-14	3/8-19	40.5	27.0
12MBSPP-6MBSPPWD	3/4-14	3/8-19	42.0	32.0
4MBSPP-8MBSPPWD	1/4-19	1/2-14	39.0	27.0
6MBSPP-8MBSPPWD	3/8-19	1/2-14	40.5	27.0
8MBSPP-8MBSPPWD	1/2-14	1/2-14	43.0	27.0
12MBSPP-8MBSPPWD	3/4-14	1/2-14	44.5	32.0
16MBSPP-8MBSPPWD	1-11	1/2-14	50.5	41.0
4MBSPP-12MBSPPWD	1/4-19	3/4-14	40.0	32.0
6MBSPP-12MBSPPWD	3/8-19	3/4-14	43.5	32.0
8MBSPP-12MBSPPWD	1/2-14	3/4-14	46.0	32.0
12MBSPP-12MBSPPWD	3/4-14	3/4-14	46.5	32.0
16MBSPP-12MBSPPWD	1-11	3/4-14	52.5	41.0
20MBSPP-12MBSPPWD	1.1/4-11	3/4-14	54.5	50.0
6MBSPP-16MBSPPWD	3/8-19	1-11	47.5	41.0
8MBSPP-16MBSPPWD	1/2-14	1-11	50.0	41.0
12MBSPP-16MBSPPWD	3/4-14	1-11	52.5	41.0
16MBSPP-16MBSPPWD	1-11	1-11	54.5	41.0





BSP ADAPTORS

BS5200

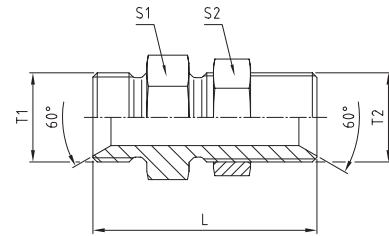
BSP MBSPP-MBSPPBKH

BSPP 60° Male / Male straight bulkhead with lock nut.



				
ref.	T1	T2	L	S1 & S2
BSP	BSPP	BSPP	mm	mm
2MBSPP-2MBSPPBKH	1/8-28	1/8-28	49.0	14.0
4MBSPP-4MBSPPBKH	1/4-19	1/4-19	53.0	19.0
6MBSPP-6MBSPPBKH	3/8-19	3/8-19	56.5	22.0
8MBSPP-8MBSPPBKH	1/2-14	1/2-14	65.0	27.0
10MBSPP-10MBSPPBKH	5/8-14	5/8-14	67.5	30.0
12MBSPP-12MBSPPBKH	3/4-14	3/4-14	71.5	32.0
16MBSPP-16MBSPPBKH	1-11	1-11	84.0	41.0
20MBSPP-20MBSPPBKH	1.1/4-11	1.1/4-11	89.5	50.0
24MBSPP-24MBSPPBKH	1.1/2-11	1.1/2-11	93.0	55.0
32MBSPP-32MBSPPBKH	2-11	2-11	97.5	70.0

BSP ADAPTORS





BS5200

THE WORLD OF ADAPTORS

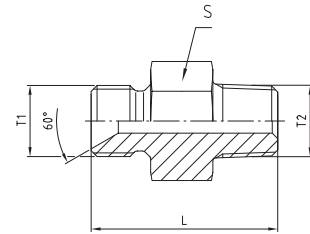
BSP MBSPP-MBSPT

BSPP 60° Male / Male BSP taper.



			
ref.	T1	T2	L
BSP	BSPP	BSPT	mm
			mm
2MBSPP-2MBSPT	1/8-28	R1/8-28	26.0
4MBSPP-2MBSPT	1/4-19	R1/8-28	28.0
2MBSPP-4MBSPT	1/8-28	R1/4-19	30.5
4MBSPP-4MBSPT	1/4-19	R1/4-19	32.0
6MBSPP-4MBSPT	3/8-19	R1/4-19	35.5
8MBSPP-4MBSPT	1/2-14	R1/4-19	40.5
4MBSPP-6MBSPT	1/4-19	R3/8-19	32.0
6MBSPP-6MBSPT	3/8-19	R3/8-19	35.5
8MBSPP-6MBSPT	1/2-14	R3/8-19	40.0
4MBSPP-8MBSPT	1/4-19	R1/2-14	40.0
6MBSPP-8MBSPT	3/8-19	R1/2-14	40.5
8MBSPP-8MBSPT	1/2-14	R1/2-14	45.0
12MBSPP-8MBSPT	3/4-14	R1/2-14	49.5
6MBSPP-12MBSPT	3/8-19	R3/4-14	40.5
8MBSPP-12MBSPT	1/2-14	R3/4-14	45.0
12MBSPP-12MBSPT	3/4-14	R3/4-14	48.5
16MBSPP-12MBSPT	1-11	R3/4-14	53.0
20MBSPP-12MBSPT	1.1/4-11	R3/4-14	56.0
12MBSPP-16MBSPT	3/4-14	R1-11	53.5
16MBSPP-16MBSPT	1-11	R1-11	58.0
20MBSPP-16MBSPT	1.1/4-11	R1-11	61.0
12MBSPP-20MBSPT	3/4-14	R1.1/4-11	58.0
16MBSPP-20MBSPT	1-11	R1.1/4-11	60.0
20MBSPP-20MBSPT	1.1/4-11	R1.1/4-11	62.0
24MBSPP-20MBSPT	1.1/2-11	R1.1/4-11	64.5
20MBSPP-24MBSPT	1.1/4-11	R1.1/2-11	62.0
24MBSPP-24MBSPT	1.1/2-11	R1.1/2-11	64.5
32MBSPP-32MBSPT	2-11	R2-11	72.5





BSP ADAPTORS

BS5200

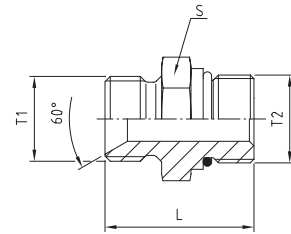
BSP MBSPP-MB

BSP 60° Male / Male UN/UNF SAE with O-Ring.



				
ref.	T1	T2	L	S
BSP	BSPP	SAE O	mm	mm
4MBSPP-4MB	1/4-19	7/16-20	29.5	19.0
4MBSPP-6MB	1/4-19	9/16-18	32.0	19.0
4MBSPP-8MB	1/4-19	3/4-16	31.0	22.0
6MBSPP-4MB	3/8-19	7/16-20	33.0	22.0
6MBSPP-6MB	3/8-19	9/16-18	33.5	22.0
6MBSPP-8MB	3/8-19	3/4-16	36.0	24.0
6MBSPP-10MB	3/8-19	7/8-14	39.5	27.0
6MBSPP-12MB	3/8-19	1.1/16-12	43.0	31.0
8MBSPP-8MB	1/2-14	3/4-16	38.0	27.0
8MBSPP-10MB	1/2-14	7/8-14	42.0	27.0
8MBSPP-12MB	1/2-14	1.1/16-12	42.5	36.0
10MBSPP-10MB	5/8-14	7/8-14	43.5	30.0
10MBSPP-12MB	5/8-14	1.1/16-12	47.0	34.0
12MBSPP-8MB	3/4-14	3/4-16	40.5	32.0
12MBSPP-10MB	3/4-14	7/8-14	45.5	32.0
12MBSPP-12MB	3/4-14	1.1/16-12	48.0	34.0
12MBSPP-16MB	3/4-14	1.5/16-12	50.7	41.0
16MBSPP-12MB	1-11	1.1/16-12	52.0	41.0
16MBSPP-16MB	1-11	1.5/16-12	52.6	41.0

BSP ADAPTORS





BS5200

THE WORLD OF ADAPTORS

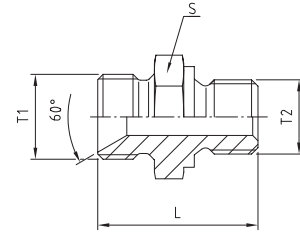
BSP MBSPP-MM

BSPP 60° Male / Male metric.



				
ref.	T1	T2	L	S
BSP	BSPP	METRIC	mm	mm
4MBSPP-10MM	1/4-19	M10X1	27.0	19.0
4MBSPP-12MM	1/4-19	M12X1.5	29.0	19.0
4MBSPP-14MM	1/4-19	M14X1.5	30.0	19.0
4MBSPP-16MM	1/4-19	M16X1.5	33.0	22.0
4MBSPP-18MM	1/4-19	M18X1.5	33.0	24.0
4MBSPP-20MM	1/4-19	M20X1.5	37.0	27.0
4MBSPP-22MM	1/4-19	M22X1.5	37.0	27.0
6MBSPP-12MM	3/8-19	M12X1.5	31.5	22.0
6MBSPP-14MM	3/8-19	M14X1.5	32.5	22.0
6MBSPP-16MM	3/8-19	M16X1.5	33.5	22.0
6MBSPP-18MM	3/8-19	M18X1.5	34.5	24.0
6MBSPP-20MM	3/8-19	M20X1.5	38.5	27.0
6MBSPP-22MM	3/8-19	M22X1.5	38.5	27.0
8MBSPP-12MM	1/2-14	M12X1.5	37.0	27.0
8MBSPP-14MM	1/2-14	M14X1.5	38.0	27.0
8MBSPP-16MM	1/2-14	M16X1.5	39.0	27.0
8MBSPP-18MM	1/2-14	M18X1.5	39.0	27.0
8MBSPP-20MM	1/2-14	M20X1.5	41.0	27.0
8MBSPP-22MM	1/2-14	M22X1.5	41.0	27.0
8MBSPP-24MM	1/2-14	M24X1.5	41.0	30.0
8MBSPP-26MM	1/2-14	M26X1.5	44.0	32.0
12MBSPP-18MM	3/4-14	M18X1.5	42.5	32.0
12MBSPP-22MM	3/4-14	M22X1.5	44.5	32.0
12MBSPP-26MM	3/4-14	M26X1.5	46.5	32.0
16MBSPP-22MM	1-11	M22X1.5	48.5	41.0
16MBSPP-26MM	1-11	M26X1.5	50.5	41.0





BSP ADAPTORS

BS5200

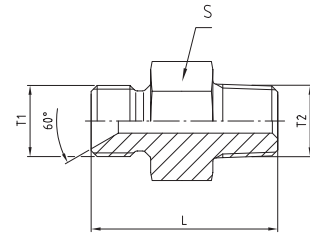
BSP MBSPP-MP

BSPP 60° Male / Male NPT.



				
ref.	T1	T2	L	S
BSP	BSPP	NPT	mm	mm
4MBSPP-4MP	1/4-19	Z1/4-18	33.0	19.0
6MBSPP-6MP	3/8-19	Z3/8-18	37.5	22.0
8MBSPP-8MP	1/2-14	Z1/2-14	45.5	27.0
12MBSPP-12MP	3/4-14	Z3/4-14	49.0	32.0
16MBSPP-16MP	1-11	Z1-11.5	59.0	41.0
32MBSPP-32MP	2-11	Z2-11.5	70.0	70.0

BSP ADAPTORS





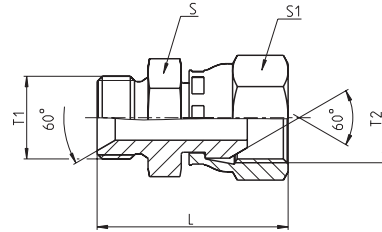

BS5200

THE WORLD OF ADAPTORS

BSP MBSPP-FBSPPX

BSP 60° Male / Female swivel.



					
ref.	T1	T2	L	S	S1
BSP	BSPP	BSPP F	mm	mm	mm
2MBSPP-2FBSPPX	1/8-28	1/8-28	25.0	14.0	14.0
2MBSPP-4FBSPPX	1/8-28	1/4-19	27.0	14.0	19.0
4MBSPP-2FBSPPX	1/4-19	1/8-28	27.0	19.0	14.0
4MBSPP-4FBSPPX	1/4-19	1/4-19	29.0	19.0	19.0
4MBSPP-6FBSPPX	1/4-19	3/8-19	30.5	19.0	22.0
4MBSPP-8FBSPPX	1/4-19	1/2-14	32.0	19.0	27.0
4MBSPP-12FBSPPX	1/4-19	3/4-14	33.0	27.0	32.0
6MBSPP-4FBSPPX	3/8-19	1/4-19	32.5	22.0	19.0
6MBSPP-6FBSPPX	3/8-19	3/8-19	34.0	22.0	22.0
6MBSPP-8FBSPPX	3/8-19	1/2-14	35.5	22.0	27.0
6MBSPP-12FBSPPX	3/8-19	3/4-14	36.5	27.0	32.0
6MBSPP-16FBSPPX	3/8-19	1-11	38.0	32.0	41.0
8MBSPP-4FBSPPX	1/2-14	1/4-19	37.0	27.0	19.0
8MBSPP-6FBSPPX	1/2-14	3/8-19	38.5	27.0	22.0
8MBSPP-8FBSPPX	1/2-14	1/2-14	40.0	27.0	27.0
8MBSPP-10FBSPPX	1/2-14	5/8-14	40.5	27.0	30.0
8MBSPP-12FBSPPX	1/2-14	3/4-14	41.0	27.0	32.0
8MBSPP-16FBSPPX	1/2-14	1-11	42.5	32.0	41.0
10MBSPP-10FBSPPX	5/8-14	5/8-14	42.0	30.0	30.0
12MBSPP-6FBSPPX	3/4-14	3/8-19	42.0	32.0	22.0
12MBSPP-8FBSPPX	3/4-14	1/2-14	43.5	32.0	27.0
12MBSPP-12FBSPPX	3/4-14	3/4-14	44.5	32.0	32.0
12MBSPP-16FBSPPX	3/4-14	1-11	46.0	32.0	41.0
12MBSPP-20FBSPPX	3/4-14	1.1/4-11	49.0	32.0	50.0
16MBSPP-8FBSPPX	1-11	1/2-14	48.0	41.0	27.0
16MBSPP-12FBSPPX	1-11	3/4-14	49.0	41.0	32.0
16MBSPP-16FBSPPX	1-11	1-11	50.0	41.0	41.0
16MBSPP-20FBSPPX	1-11	1.1/4-11	53.0	41.0	50.0
16MBSPP-24FBSPPX	1-11	1.1/2-11	53.5	55.0	55.0
20MBSPP-12FBSPPX	1.1/4-11	3/4-14	50.5	50.0	32.0
20MBSPP-16FBSPPX	1.1/4-11	1-11	52.0	50.0	41.0
20MBSPP-20FBSPPX	1.1/4-11	1.1/2-11	55.0	50.0	50.0
20MBSPP-24FBSPPX	1.1/4-11	1.1/2-11	55.5	50.0	55.0
20MBSPP-32FBSPPX	1.1/4-11	2-11	58.5	50.0	70.0
24MBSPP-16FBSPPX	1.1/2-11	1-11	54.5	55.0	41.0
24MBSPP-20FBSPPX	1.1/2-11	1.1/4-11	57.5	55.0	50.0
24MBSPP-24FBSPPX	1.1/2-11	1.1/2-11	58.0	55.0	55.0
24MBSPP-32FBSPPX	1.1/2-11	2-11	60.0	55.0	70.0
32MBSPP-20FBSPPX	2-11	1.1/4-11	60.0	70.0	50.0
32MBSPP-24FBSPPX	2-11	1.1/2-11	60.5	70.0	55.0
32MBSPP-32FBSPPX	2-11	2-11	63.5	70.0	70.0





BSP ADAPTORS

BS5200

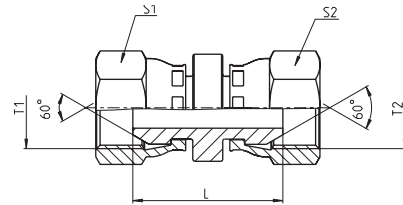
BSP FBSPPX-FBSPPX

BSPP 60° Female swivel / Female swivel.



					
ref.	T1	T2	L	S1	S2
BSP	BSPP F	BSPP F	mm	mm	mm
2FBSPPX-2FBSPPX	1/8-28	1/8-28	21.0	14.0	14.0
4FBSPPX-4FBSPPX	1/4-19	1/4-19	25.0	19.0	19.0
4FBSPPX-6FBSPPX	1/4-19	3/8-19	26.5	19.0	22.0
4FBSPPX-8FBSPPX	1/4-19	1/2-14	28.5	19.0	27.0
6FBSPPX-6FBSPPX	3/8-19	3/8-19	27.0	22.0	22.0
6FBSPPX-8FBSPPX	3/8-19	1/2-14	29.5	22.0	27.0
8FBSPPX-8FBSPPX	1/2-14	1/2-14	31.0	27.0	27.0
8FBSPPX-10FBSPPX	1/2-14	5/8-14	31.5	27.0	30.0
8FBSPPX-12FBSPPX	1/2-14	3/4-14	32.5	27.0	32.0
10FBSPPX-10FBSPPX	5/8-14	5/8-14	31.5	30.0	30.0
12FBSPPX-12FBSPPX	3/4-14	3/4-14	33.5	32.0	32.0
12FBSPPX-16FBSPPX	3/4-14	1-11	35.0	32.0	41.0
16FBSPPX-16FBSPPX	1-11	1-11	36.5	41.0	41.0
20FBSPPX-20FBSPPX	1.1/4-11	1.1/4-11	40.0	50.0	50.0
24FBSPPX-24FBSPPX	1.1/2-11	1.1/2-11	47.0	55.0	55.0
32FBSPPX-32FBSPPX	2-11	2-11	47.0	70.0	70.0

BSP ADAPTORS





BS5200

THE WORLD OF ADAPTORS

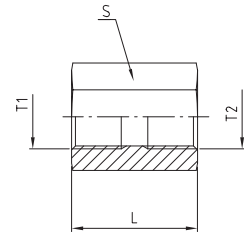
BSP FBSPP-FBSPP

BSP Female fixed / Female fixed.





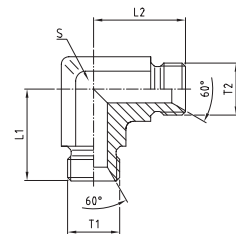

				
ref.	T1	T2	L	S
BSP	BSPP F	BSPP F	mm	mm
2FBSPP-2FBSPP	1/8-28	1/8-28	22.0	14.0
4FBSPP-4FBSPP	1/4-19	1/4-19	24.0	19.0
6FBSPP-6FBSPP	3/8-19	3/8-19	26.0	22.0
8FBSPP-8FBSPP	1/2-14	1/2-14	32.0	27.0
10FBSPP-10FBSPP	5/8-14	5/8-14	36.0	30.0
12FBSPP-12FBSPP	3/4-14	3/4-14	36.0	32.0
16FBSPP-16FBSPP	1-11	1-11	40.0	41.0
20FBSPP-20FBSPP	1.1/4-11	1.1/4-11	44.0	50.0
24FBSPP-24FBSPP	1.1/2-11	1.1/2-11	45.0	55.0
32FBSPP-32FBSPP	2-11	2-11	54.0	70.0

BSP MBSPP-MBSPP90BL

BSP 60° Male / Male 90° compact elbow (forged).



					
ref.	T1	T2	L1	L2	S Flats
BSP	BSPP	BSPP	mm	mm	mm
4MBSPP-4MBSPP90BL	1/4-19	1/4-19	24.5	24.5	14.0
6MBSPP-6MBSPP90BL	3/8-19	3/8-19	27.5	27.5	16.0
8MBSPP-8MBSPP90BL	1/2-14	1/2-14	34.5	34.5	22.0
12MBSPP-12MBSPP90BL	3/4-14	3/4-14	40.0	40.0	27.0
16MBSPP-16MBSPP90BL	1-11	1-11	46.0	46.0	33.0





BSP ADAPTORS

BS5200

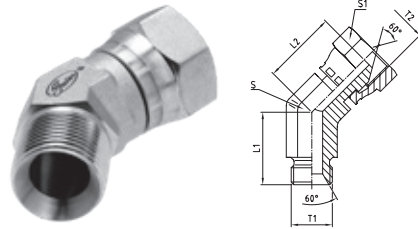
BSP MBSPP-FBSPPX45BL

BSPP 60° Male / Female Swivel 45° compact elbow (forged).





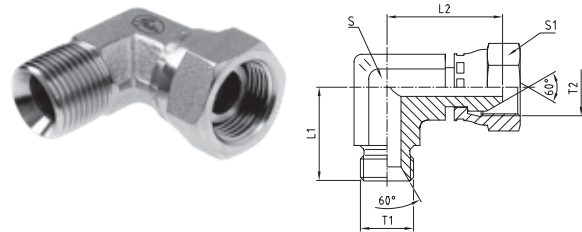

						
ref.	T1	T2	L1	L2	S Flats	S1
BSP	BSPP	BSPP F	mm	mm	mm	mm
4MBSPP-4FBSPPX45BL	1/4-19	1/4-19	20.3	23.5	14.0	19.0
6MBSPP-6FBSPPX45BL	3/8-19	3/8-19	22.0	26.7	16.0	22.0
8MBSPP-8FBSPPX45BL	1/2-14	1/2-14	27.0	29.5	22.0	27.0
12MBSPP-12FBSPPX45BL	3/4-14	3/4-14	31.0	34.1	27.0	32.0
16MBSPP-16FBSPPX45BL	1-11	1-11	35.0	38.3	33.0	41.0

BSP MBSPP-FBSPPX90BL

BSPP 60° Male / Female Swivel 90° compact elbow (forged).



						
ref.	BSPP	BSPP F	L1	L2	S Flats	S1
BSP	BSPP	BSPP F	mm	mm	mm	mm
4MBSPP-4FBSPPX90BL	1/4-19	1/4-19	24.5	24.0	14.0	19.0
6MBSPP-6FBSPPX90BL	3/8-19	3/8-19	27.5	26.7	16.0	22.0
8MBSPP-8FBSPPX90BL	1/2-14	1/2-14	34.5	34.3	22.0	27.0
10MBSPP-10FBSPPX90BL	5/8-14	5/8-14	35.0	34.3	22.0	30.0
12MBSPP-12FBSPPX90BL	3/4-14	3/4-14	40.0	36.5	27.0	32.0
16MBSPP-16FBSPPX90BL	1-11	1-11	46.0	43.2	33.0	41.0
20MBSPP-20FBSPPX90BL	1.1/4-11	1.1/4-11	50.5	46.4	41.0	50.0

BSP ADAPTORS





BS5200

THE WORLD OF ADAPTORS

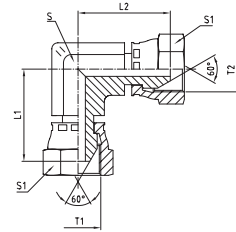
BSP FBSPPX-FBSPPX90BL

BSPP 60° Female swivel / Female swivel
90° compact elbow (forged).





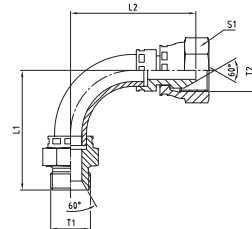

						
ref.	T1	T2	L1	L2	S Flats	S1
BSP	BSPP F	BSPP F	mm	mm	mm	mm
4FBSPPX-4FBSPPX90BL	1/4-19	1/4-19	24.0	24.0	11.0	19.0
6FBSPPX-6FBSPPX90BL	3/8-19	3/8-19	26.7	26.7	14.0	22.0
8FBSPPX-8FBSPPX90BL	1/2-14	1/2-14	34.3	34.3	19.0	27.0
10FBSPPX-10FBSPPX90BL	5/8-14	5/8-14	34.3	34.3	22.0	30.0
12FBSPPX-12FBSPPX90BL	3/4-14	3/4-14	36.5	36.5	24.0	32.0
16FBSPPX-16FBSPPX90BL	1-11	1-11	43.2	43.2	30.0	41.0
20FBSPPX-20FBSPPX90BL	1.1/4-11	1.1/4-11	46.4	46.4	36.0	50.0

BSP MBSPP-FBSPPX90SWT

BSPP 60° Male / Female swivel 90° swept elbow.



					
ref.	T1	T2	L1	L2	S1
BSP	BSPP	BSPP F	mm	mm	mm
4MBSPP-4FBSPPX90SWT	1/4-19	1/4-19	43.0	33.6	19.0
6MBSPP-6FBSPPX90SWT	3/8-19	3/8-19	51.6	41.3	22.0
8MBSPP-8FBSPPX90SWT	1/2-14	1/2-14	59.8	48.6	27.0
10MBSPP-10FBSPPX90SWT	5/8-14	5/8-14	70.0	52.5	30.0
12MBSPP-12FBSPPX90SWT	3/4-14	3/4-14	73.9	62.1	32.0
16MBSPP-16FBSPPX90SWT	1-11	1-11	93.7	72.8	41.0
20MBSPP-20FBSPPX90BL	1.1/4-11	1.1/4-11	110.7	85.9	50.0





BSP ADAPTORS

BS5200

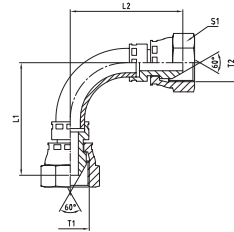
BSP FBSPPX-FBSPPX90SWT

BSPP 60° Female swivel / Female swivel
90° swept elbow.





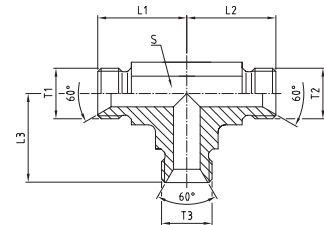

						
ref.	T1	T2	L1	L2	S1	
BSP	BSPP F	BSPP F	mm	mm	mm	
4FBSPPX-4FBSPPX90SWT	1/4-19	1/4-19	27.0	27.0	19.0	
6FBSPPX-6FBSPPX90SWT	3/8-19	3/8-19	33.0	33.0	22.0	
8FBSPPX-8FBSPPX90SWT	1/2-14	1/2-14	38.0	38.0	27.0	
10FBSPPX-10FBSPPX90SWT	5/8-14	5/8-14	52.5	52.5	30.0	
12FBSPPX-12FBSPPX90SWT	3/4-14	3/4-14	58.0	58.0	32.0	
16FBSPPX-16FBSPPX90SWT	1-11	1-11	74.0	74.0	41.0	
20FBSPPX-20FBSPPX90SWT	1.1/4-11	1.1/4-11	92.0	92.0	50.0	

BSP MBSPP-MBSPP-MBSPP

BSPP 60° Male / Male / Male "T" (forged).



						
ref.	T1	T2	T3	L1 . L2	L3	S Flats
BSP	BSPP	BSPP	BSPP	mm	mm	mm
4MBSPP-4MBSPP-4MBSPP	1/4-19	1/4-19	1/4-19	24.5	24.5	14.0
6MBSPP-6MBSPP-6MBSPP	3/8-19	3/8-19	3/8-19	27.5	27.5	16.0
8MBSPP-8MBSPP-8MBSPP	1/2-14	1/2-14	1/2-14	34.5	34.5	22.0
10MBSPP-10MBSPP-10MBSPP	5/8-14	5/8-14	5/8-14	35.0	35.0	22.0
12MBSPP-12MBSPP-12MBSPP	3/4-14	3/4-14	3/4-14	40.0	40.0	27.0
16MBSPP-16MBSPP-16MBSPP	1-11	1-11	1-11	46.0	46.0	33.0
20MBSPP-20MBSPP-20MBSPP	1.1/4-11	1.1/4-11	1.1/4-11	50.5	50.5	41.0
24MBSPP-24MBSPP-24MBSPP	1.1/2-11	1.1/2-11	1.1/2-11	57.5	57.5	48.0

BSP ADAPTORS





BS5200

THE WORLD OF ADAPTORS

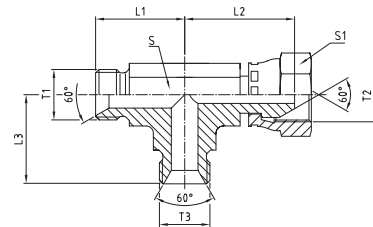
BSP MBSPP-FBSPPX-MBSPP

BSPP 60° Male / Female swivel /
Male "T" (forged).





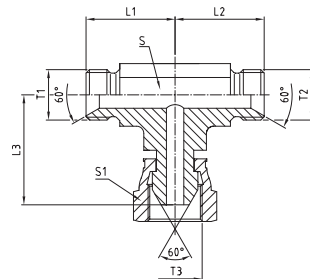

							
ref.	T1	T2	T3	L1 . L3	L2	S Flats	S1
BSP	BSPP	BSPP F	BSPP	mm	mm	mm	mm
4MBSPP-4FBSPPX-4MBSPP	1/4-19	1/4-19	1/4-19	25.0	24.0	14.0	19.0
6MBSPP-6FBSPPX-6MBSPP	3/8-19	3/8-19	3/8-19	27.5	26.7	16.0	22.0
8MBSPP-8FBSPPX-8MBSPP	1/2-14	1/2-14	1/2-14	34.5	34.3	22.0	27.0
12MBSPP-12FBSPPX-12MBSPP	3/4-14	3/4-14	3/4-14	40.0	36.5	27.0	32.0
16MBSPP-16FBSPPX-16MBSPP	1-11	1-11	1-11	46.0	43.2	33.0	41.0
20MBSPP-20FBSPPX-20MBSPP	1.1/4-11	1.1/4-11	1.1/4-11	50.5	46.4	41.0	50.0

BSP MBSPP-MBSPP-FBSPPX

BSPP 60° Male / Male /
Female swivel "T" (forged).



							
ref.	T1	T2	T3	L1 . L2	L3	S Flats	S1
BSP	BSPP	BSPP	BSPP F	mm	mm	mm	mm
4MBSPP-4MBSPP-4FBSPPX	1/4-19	1/4-19	1/4-19	24.5	24.0	14.0	19.0
6MBSPP-6MBSPP-6FBSPPX	3/8-19	3/8-19	3/8-19	27.5	26.7	16.0	22.0
8MBSPP-8MBSPP-8FBSPPX	1/2-14	1/2-14	1/2-14	34.5	34.3	22.0	27.0
12MBSPP-12MBSPP-12FBSPPX	3/4-14	3/4-14	3/4-14	40.0	36.5	27.0	32.0
16MBSPP-16MBSPP-16FBSPPX	1-11	1-11	1-11	46.0	43.2	33.0	41.0
20MBSPP-20MBSPP-20FBSPPX	1.1/4-11	1.1/4-11	1.1/4-11	50.5	46.4	41.0	50.0

BSP ADAPTORS

BS5200

BSP FBSPPX-FBSPPX-FBSPPX

BSPP 60° Female swivel / Female swivel /
Female swivel "T" (forged).

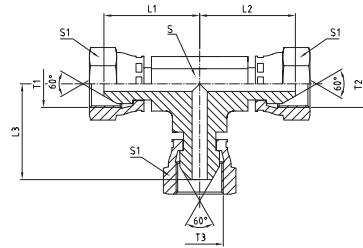
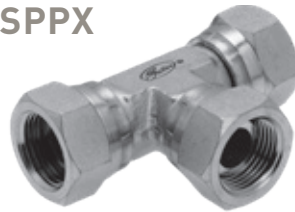

ref.	T1 T2 T3			L1 . L2 L3		S Flats S1	
	BSPP F	BSPP F	BSPP F	mm	mm	mm	mm
4FBSPPX-4FBSPPX-4FBSPPX	1/4-19	1/4-19	1/4-19	24.0	24.0	11.0	19.0
6FBSPPX-6FBSPPX-6FBSPPX	3/8-19	3/8-19	3/8-19	26.7	26.7	16.0	22.0
8FBSPPX-8FBSPPX-8FBSPPX	1/2-14	1/2-14	1/2-14	34.3	34.3	19.0	27.0
10FBSPPX-10FBSPPX-10FBSPPX	5/8-14	5/8-14	5/8-14	34.3	34.3	22.0	30.0
12FBSPPX-12FBSPPX-12FBSPPX	3/4-14	3/4-14	3/4-14	36.5	36.5	24.0	32.0
16FBSPPX-16FBSPPX-16FBSPPX	1-11	1-11	1-11	43.2	43.2	30.0	41.0
20FBSPPX-20FBSPPX-20FBSPPX	1.1/4-11	1.1/4-11	1.1/4-11	46.4	46.4	41.0	50.0
24FBSPPX-24FBSPPX-24FBSPPX	1.1/2-11	1.1/2-11	1.1/2-11	54.5	54.5	48.0	55.0

BSP MBSPP-FBSPPX-FBSPPX

BSPP 60° Male / Female swivel /
Female swivel "T" (forged).

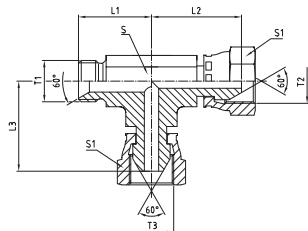

ref.	T1 T2 T3			L1 L2 . L3		S Flats S1	
	BSPP	BSPP F	BSPP F	mm	mm	mm	mm
4MBSPP-4FBSPPX-4FBSPPX	1/4-19	1/4-19	1/4-19	25.0	24.0	14.0	19.0
6MBSPP-6FBSPPX-6FBSPPX	3/8-19	3/8-19	3/8-19	27.5	26.7	16.0	22.0
8MBSPP-8FBSPPX-8FBSPPX	1/2-14	1/2-14	1/2-14	34.5	34.3	22.0	27.0
12MBSPP-12FBSPPX-12FBSPPX	3/4-14	3/4-14	3/4-14	40.0	36.5	27.0	32.0
16MBSPP-16FBSPPX-16FBSPPX	1-11	1-11	1-11	46.0	43.2	33.0	41.0

BSP ADAPTORS





BS5200

THE WORLD OF ADAPTORS

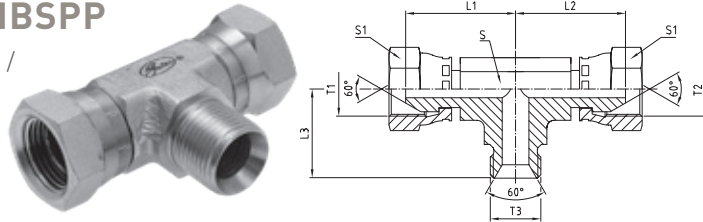
BSP FBSPPX-FBSPPX-MBSPP

BSPP 60° Female swivel / Female swivel / Male "T" (forged).





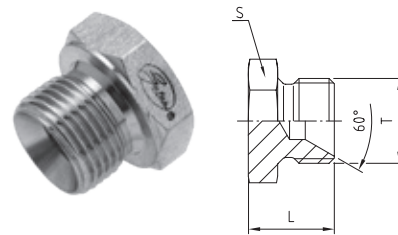

							
ref.	T1	T2	T3	L1 . L2	L3	S Flats	S1
BSP	BSPP F	BSPP F	BSPP	mm	mm	mm	mm
4FBSPPX-4FBSPPX-4MBSPP	1/4-19	1/4-19	1/4-19	24.0	25.0	14.0	19.0
6FBSPPX-6FBSPPX-6MBSPP	3/8-19	3/8-19	3/8-19	26.7	27.5	16.0	22.0
8FBSPPX-8FBSPPX-8MBSPP	1/2-14	1/2-14	1/2-14	34.3	34.5	22.0	27.0
10FBSPPX-10FBSPPX-10MBSPP	5/8-14	5/8-14	5/8-14	34.3	34.5	22.0	30.0
12FBSPPX-12FBSPPX-12MBSPP	3/4-14	3/4-14	3/4-14	36.5	40.0	27.0	32.0
16FBSPPX-16FBSPPX-16MBSPP	1-11	1-11	1-11	43.2	46.0	33.0	41.0

BSP MBSPP-PLUG

BSPP 60° Male cone plug.



				
ref.	T	L		S
BSP	BSPP	mm		mm
2MBSPP-PLUG	1/8-28	16.0		14.0
4MBSPP-PLUG	1/4-19	18.0		19.0
6MBSPP-PLUG	3/8-19	21.5		22.0
8MBSPP-PLUG	1/2-14	26.0		27.0
10MBSPP-PLUG	5/8-14	27.5		30.0
12MBSPP-PLUG	3/4-14	29.5		32.0
16MBSPP-PLUG	1-11	34.0		41.0
20MBSPP-PLUG	1.1/4-11	37.5		50.0
24MBSPP-PLUG	1.1/2-11	40.0		55.0
32MBSPP-PLUG	2-11	43.5		70.0





BSP ADAPTORS

BS5200

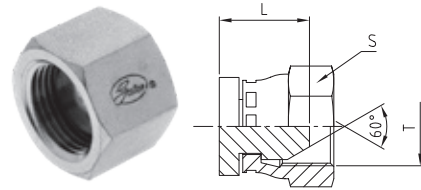
BSP FBSPPX-CAP

BSPP 60° Female swivel cap.



			
ref.	T	L	S
BSP	BSPP	mm	mm
2FBSPPX-CAP	1/8-28	13.8	14.0
4FBSPPX-CAP	1/4-19	16.9	19.0
6FBSPPX-CAP	3/8-19	17.4	22.0
8FBSPPX-CAP	1/2-14	20.2	27.0
10FBSPPX-CAP	5/8-14	19.6	30.0
12FBSPPX-CAP	3/4-14	21.9	32.0
16FBSPPX-CAP	1-11	23.6	41.0
20FBSPPX-CAP	1.1/4-11	28.4	50.0
24FBSPPX-CAP	1.1/2-11	28.5	55.0
32FBSPPX-CAP	2-11	31.5	70.0

THE WORLD OF ADAPTORS
INTEGRATED FLUID POWER SOLUTIONS



JIC ADAPTORS



JIC ADAPTORS





ISO 8434-2 AND SAE J514

THE WORLD OF ADAPTORS

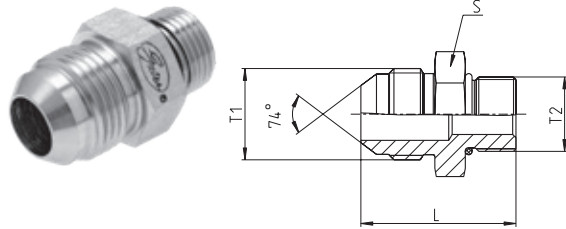
JIC MJ-MMOR

JIC 37° Male / Male metric with O-ring.





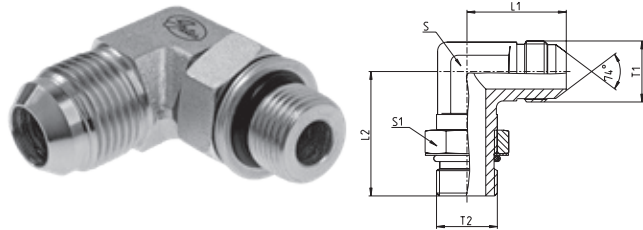

				
ref.	T1	T2	L	S
JIC	JIC	Metric	mm	mm
4MJ-10MMOR	7/16-20	M10x1	30.0	14.0
6MJ-14MMOR	9/16-18	M14x1.5	34.0	19.0
6MJ-16MMOR	9/16-18	M16x1.5	36.0	22.0
6MJ-18MMOR	9/16-18	M18x1.5	37.0	24.0
8MJ-16MMOR	3/4-16	M16x1.5	38.0	22.0
8MJ-18MMOR	3/4-16	M18x1.5	39.0	24.0
10MJ-14MMOR	7/8-14	M14x1.5	41.0	24.0
10MJ-18MMOR	7/8-14	M18x1.5	43.0	24.0
10MJ-22MMOR	7/8-14	M22x1.5	44.0	27.0
12MJ-22MMOR	1.1/16-12	M22x1.5	48.0	27.0
12MJ-27MMOR	1.1/16-12	M27x2	51.0	32.0

JIC MJ-MMAOR90

JIC 37° Male / Adjustable male metric 90° elbow with O-ring.



						
ref.	T1	T2	L1	L2	S Flats	S1
JIC	JIC	Metric	mm	mm	mm	mm
5MJ-12MMAOR90	1/2-20	M12x1.5	24.0	31.0	13.0	17.0
6MJ-14MMAOR90	9/16-18	M14x1.5	27.0	34.0	14.0	19.0
8MJ-18MMAOR90	3/4-16	M18x1.5	32.0	38.0	19.0	24.0
10MJ-18MMAOR90	7/8-14	M18x1.5	37.0	42.0	22.0	24.0
10MJ-22MMAOR90	7/8-14	M22x1.5	37.0	43.0	22.0	27.0
12MJ-22MMAOR90	1.1/16-12	M22x1.5	42.0	45.0	24.0	27.0
12MJ-27MMAOR90	1.1/16-12	M27x2	42.0	50.0	27.0	32.0





JIC ADAPTORS

ISO 8434-2 AND SAE J514

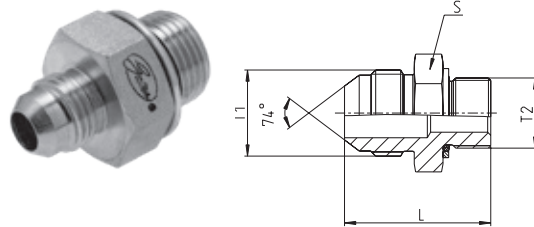
JIC MJ-MMCOR

JIC 37° / Male metric with O-ring and retaining ring.





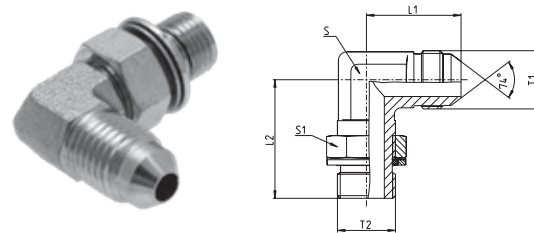

			
ref.	T1	T2	L
JIC	JIC	Metric	mm
6MJ-14MMCOR	9/16-18	M14x1.5	34.0
6MJ-18MMCOR	9/16-18	M18x1.5	37.0

JIC MJ-MMACOR90

JIC 37° Male / Adjustable male metric 90° elbow with O-ring and retaining ring.



						
ref.	T1	T2	L1	L2	S Flats	S1
JIC	JIC	Metric	mm	mm	mm	mm
4MJ-10MMACOR90	7/16-20	M10x1	23.0	27.0	11.0	13.0

JIC ADAPTORS





ISO 8434-2 AND SAE J514

THE WORLD OF ADAPTORS

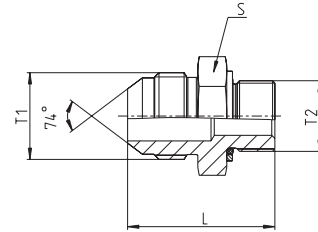
JIC MJ-MBSPPCOR

JIC 37° Male / Male BSPP with O-ring and retaining ring.



				
ref.	T1	T2	L	
JIC	JIC	BSPP	mm	
			S	
			mm	
4MJ-2MBSPPCOR	7/16-20	1/8-28	28.0	16.0
4MJ-4MBSPPCOR	7/16-20	1/4-19	32.0	19.0
4MJ-6MBSPPCOR	7/16-20	3/8-19	33.0	22.0
4MJ-8MBSPPCOR	7/16-20	1/2-14	39.0	30.0
6MJ-4MBSPPCOR	9/16-18	1/4-19	33.0	19.0
6MJ-2MBSPPCOR	9/16-18	1/8-28	29.0	17.0
6MJ-6MBSPPCOR	9/16-18	3/8-19	33.0	22.0
6MJ-8MBSPPCOR	9/16-18	1/2-14	38.0	30.0
8MJ-6MBSPPCOR	3/4-16	3/8-19	36.0	22.0
8MJ-4MBSPPCOR	3/4-16	1/4-19	35.0	19.0
8MJ-8MBSPPCOR	3/4-16	1/2-14	41.0	30.0
8MJ-12MBSPPCOR	3/4-16	3/4-14	42.0	36.0
8MJ-16MBSPPCOR	3/4-16	1-11	47.0	46.0
10MJ-8MBSPPCOR	7/8-14	1/2-14	43.0	30.0
10MJ-6MBSPPCOR	7/8-14	3/8-19	39.0	24.0
10MJ-12MBSPPCOR	7/8-14	3/4-14	45.0	36.0
12MJ-12MBSPPCOR	1.1/16-12	3/4-14	48.0	36.0
16MJ-16MBSPPCOR	1.5/16-12	1-11	54.0	46.0
16MJ-12MBSPPCOR	1.5/16-12	3/4-14	49.0	36.0
16MJ-20MBSPPCOR	1.5/16-12	1.1/4-11	55.0	50.0
24MJ-20MBSPPCOR	1.7/8-12	1.1/4-11	60.0	50.0





JIC ADAPTORS

ISO 8434-2 AND SAE J514

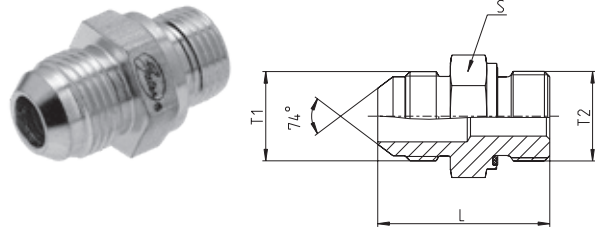
JIC MJ-MBSPPWD

JIC 37° Male / Male BSPP with captive seal.



				
ref.	T1	T2	L	
JIC	JIC	BSPP	mm	
			S	
			mm	
4MJ-2MBSPPWD	7/16-20	1/8-28	28.0	16.0
4MJ-4MBSPPWD	7/16-20	1/4-19	32.0	19.0
4MJ-6MBSPPWD	7/16-20	3/8-19	33.0	22.0
4MJ-8MBSPPWD	7/16-20	1/2-14	39.0	27.0
5MJ-2MBSPPWD	1/2-20	1/8-28	28.0	17.0
5MJ-4MBSPPWD	1/2-20	1/4-19	32.0	19.0
5MJ-6MBSPPWD	1/2-20	3/8-19	33.0	22.0
6MJ-4MBSPPWD	9/16-18	1/4-19	33.0	19.0
6MJ-6MBSPPWD	9/16-18	3/8-19	33.0	22.0
6MJ-8MBSPPWD	9/16-18	1/2-14	38.0	30.0
8MJ-6MBSPPWD	3/4-16	3/8-19	36.0	22.0
8MJ-4MBSPPWD	3/4-16	1/4-19	35.0	19.0
8MJ-8MBSPPWD	3/4-16	1/2-14	41.0	30.0
8MJ-12MBSPPWD	3/4-16	3/4-14	42.0	36.0
8MJ-16MBSPPWD	3/4-16	1-11	47.0	46.0
10MJ-8MBSPPWD	7/8-14	1/2-14	43.0	30.0
10MJ-6MBSPPWD	7/8-14	3/8-19	39.0	24.0
10MJ-12MBSPPWD	7/8-14	3/4-14	45.0	36.0
12MJ-12MBSPPWD	1.1/16-12	3/4-14	48.0	36.0
12MJ-8MBSPPWD	1.1/16-12	1/2-14	47.0	30.0
12MJ-16MBSPPWD	1.1/16-12	1-11	53.0	46.0
16MJ-16MBSPPWD	1.5/16-12	1-11	54.0	46.0
16MJ-12MBSPPWD	1.5/16-12	3/4-14	49.0	36.0
16MJ-20MBSPPWD	1.5/16-12	1.1/4-11	55.0	50.0

JIC ADAPTORS





ISO 8434-2 AND SAE J514

THE WORLD OF ADAPTORS

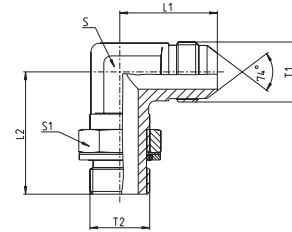
JIC MJ-MBSPPACOR90

JIC 37° Male / Adjustable male BSPP
90° elbow with O-ring and retaining ring.



						
ref.	T1	T2	L1	L2	S Flats	S1
JIC	JIC	BSPP	mm	mm	mm	mm
4MJ-2MBSPPACOR90	7/16-20	1/8-28	23.0	27.0	11.0	14.0
4MJ-4MBSPPACOR90	7/16-20	1/4-19	27.0	32.0	14.0	19.0
4MJ-6MBSPPACOR90	7/16-20	3/8-19	29.0	27.0	19.0	22.0
5MJ-2MBSPPACOR90	1/2-20	1/8-28	24.0	27.0	13.0	14.0
5MJ-4MBSPPACOR90	1/2-20	1/4-19	27.0	32.0	14.0	19.0
5MJ-6MBSPPACOR90	1/2-20	3/8-19	29.0	37.0	19.0	22.0
6MJ-4MBSPPACOR90	9/16-18	1/4-19	27.0	32.0	14.0	19.0
6MJ-6MBSPPACOR90	9/16-18	3/8-19	29.0	37.0	19.0	22.0
6MJ-8MBSPPACOR90	9/16-18	1/2-14	31.0	43.0	22.0	27.0
8MJ-6MBSPPACOR90	3/4-16	3/8-19	32.0	37.0	19.0	22.0
8MJ-4MBSPPACOR90	3/4-16	1/4-19	32.0	37.0	19.0	19.0
8MJ-8MBSPPACOR90	3/4-16	1/2-14	34.0	43.0	22.0	27.0
8MJ-12MBSPPACOR90	3/4-16	3/4-14	36.0	50.0	27.0	36.0
10MJ-8MBSPPACOR90	7/8-14	1/2-14	37.0	43.0	22.0	27.0
10MJ-6MBSPPACOR90	7/8-14	3/8-19	37.0	36.0	22.0	22.0
10MJ-12MBSPPACOR90	7/8-14	3/4-14	39.0	50.0	27.0	36.0
12MJ-12MBSPPACOR90	1.1/16-12	3/4-14	42.0	50.0	27.0	36.0
12MJ-8MBSPPACOR90	1.1/16-12	1/2-14	42.0	50.0	27.0	27.0
12MJ-16MBSPPACOR90	1.1/16-12	1-11	45.0	52.0	33.0	41.0
16MJ-16MBSPPACOR90	1.5/16-12	1-11	46.0	52.0	33.0	41.0
16MJ-12MBSPPACOR90	1.5/16-12	3/4-14	46.0	47.0	33.0	36.0
20MJ-20MBSPPACOR90	1.5/8-12	1.1/4-11	52.0	57.0	41.0	50.0
24MJ-24MBSPPACOR90	1.7/8-12	1.1/2-11	59.0	61.0	48.0	55.0





JIC ADAPTORS

ISO 8434-2 AND SAE J514

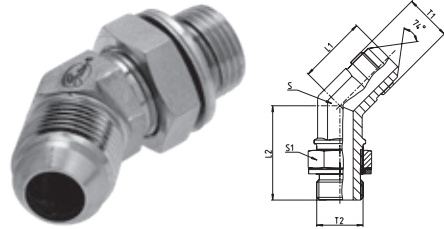
JIC MJ-MBSPPACOR45

JIC 37° Male / Adjustable male BSPP 45° elbow with O-ring and retaining ring.



						
ref.	T1	T2	L1	L2	S Flats	S1
JIC	JIC	BSPP	mm	mm	mm	mm
4MJ-2MBSPPACOR45	7/16-20	1/8-28	18.0	27.0	11.0	14.0
4MJ-4MBSPPACOR45	7/16-20	1/4-19	21.0	29.0	14.0	19.0
6MJ-4MBSPPACOR45	9/16-18	1/4-19	21.0	29.0	14.0	19.0
6MJ-6MBSPPACOR45	9/16-18	3/8-19	22.0	33.0	19.0	22.0
6MJ-8MBSPPACOR45	9/16-18	1/2-14	22.0	39.0	22.0	27.0
8MJ-6MBSPPACOR45	3/4-16	3/8-19	25.0	33.0	19.0	22.0
8MJ-8MBSPPACOR45	3/4-16	1/2-14	25.0	39.0	22.0	27.0
10MJ-8MBSPPACOR45	7/8-14	1/2-14	28.0	39.0	22.0	27.0
10MJ-12MBSPPACOR45	7/8-14	3/4-14	30.0	44.0	27.0	36.0
12MJ-12MBSPPACOR45	1.1/16-12	3/4-14	33.0	44.0	27.0	36.0
16MJ-16MBSPPACOR45	1.5/16-12	1-11	37.0	47.0	33.0	41.0

JIC ADAPTORS





ISO 8434-2 AND SAE J514

THE WORLD OF ADAPTORS

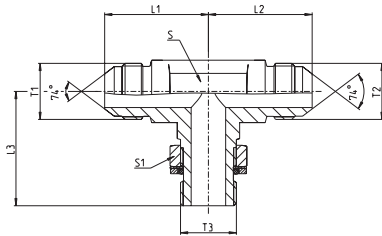
JIC MJ-MJ-MBSPPACOR

JIC 37° Male / Male / Adjustable male BSPP with O-ring and retaining ring "Branch T".





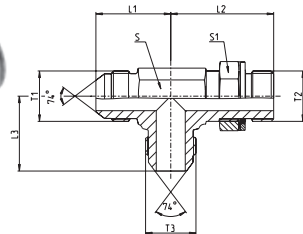

							
ref.	T1	T2	T3	L1 . L2	L3	S Flats	S1
JIC	JIC	JIC	BSPP	mm	mm	mm	mm
4MJ-4MJ-2MBSPPACOR	7/16-20	7/16-20	1/8-28	23.0	27.0	11.0	14.0
6MJ-6MJ-4MBSPPACOR	9/16-18	9/16-18	1/4-19	27.0	32.0	14.0	19.0
8MJ-8MJ-6MBSPPACOR	3/4-16	3/4-16	3/8-19	32.0	37.0	19.0	22.0
8MJ-8MJ-8MBSPPACOR	3/4-16	3/4-16	1/2-14	34.0	44.0	22.0	27.0
10MJ-10MJ-8MBSPPACOR	7/8-14	7/8-14	1/2-14	27.0	43.0	22.0	27.0
12MJ-12MJ-12MBSPPACOR	1.1/16-12	1.1/16-12	3/4-14	42.0	50.0	27.0	36.0
16MJ-16MJ-16MBSPPACOR	1.5/16-12	1.5/16-12	1-11	46.0	52.0	33.0	41.0

JIC MJ-MBSPPACOR-MJ

JIC 37° Male / Adjustable male BSPP with O-ring and retaining ring / Male "Run T".



							
ref.	T1	T2	T3	L1 . L3	L2	S Flats	S1
JIC	JIC	BSPP	JIC	mm	mm	mm	mm
4MJ-2MBSPPACOR-4MJ	7/16-20	1/8-28	7/16-20	23.0	27.0	11.0	14.0
6MJ-4MBSPPACOR-6MJ	9/16-18	1/4-19	9/16-18	27.0	32.0	14.0	19.0
8MJ-6MBSPPACOR-8MJ	3/4-16	3/8-19	3/4-16	32.0	37.0	19.0	22.0
10MJ-8MBSPPACOR-10MJ	7/8-14	1/2-14	7/8-14	37.0	43.0	22.0	27.0
12MJ-12MBSPPACOR-12MJ	1.1/16-12	3/4-14	1.1/16-12	42.0	50.0	27.0	27.0
16MJ-16MBSPPACOR-16MJ	1.5/16-12	1-11	1.5/16-12	43.0	52.0	33.0	36.0





JIC ADAPTORS

ISO 8434-2 AND SAE J514

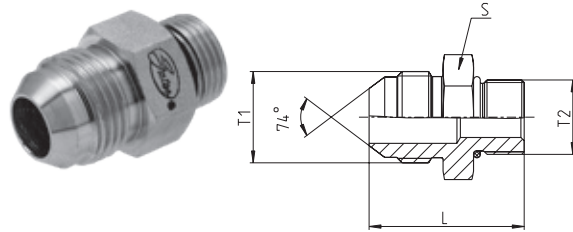
JIC MJ-MB

JIC 37° Male / Male UN/UNF SAE with O-ring.



				
ref.	T1	T2	L	
JIC	JIC	SAE O	mm	
			S	
			mm	
4MJ-4MB	7/16-20	7/16-20	31.0	14.0
4MJ-6MB	7/16-20	9/16-18	33.0	17.0
5MJ-5MB	1/2-20	1/2-20	31.0	16.0
5MJ-4MB	1/2-20	7/16-20	31.0	14.0
5MJ-6MB	1/2-20	9/16-18	33.0	17.0
6MJ-6MB	9/16-18	9/16-18	33.0	17.0
6MJ-4MB	9/16-18	7/16-20	32.0	16.0
6MJ-8MB	9/16-18	3/4-16	35.0	22.0
6MJ-10MB	9/16-18	7/8-14	38.0	25.0
6MJ-12MB	9/16-18	1.1/16-12	41.0	32.0
8MJ-8MB	3/4-16	3/4-16	38.0	22.0
8MJ-6MB	3/4-16	9/16-18	37.0	19.0
8MJ-10MB	3/4-16	7/8-14	41.0	27.0
8MJ-12MB	3/4-16	1.1/16-12	45.0	32.0
10MJ-10MB	7/8-14	7/8-14	43.0	27.0
10MJ-8MB	7/8-14	3/4-16	42.0	24.0
10MJ-12MB	7/8-14	1.1/16-12	47.0	32.0
12MJ-12MB	1.1/16-12	1.1/16-12	50.0	32.0
12MJ-8MB	1.1/16-12	3/4-14	49.0	29.0
16MJ-16MB	1.5/16-12	1.5/16-12	52.0	38.0
16MJ-12MB	1.5/16-12	1.1/16-12	52.0	36.0
16MJ-20MB	1.5/16-12	1.5/8-12	54.0	48.0

JIC ADAPTORS





ISO 8434-2 AND SAE J514

THE WORLD OF ADAPTORS

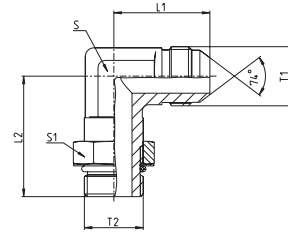
JIC MJ-MBA90

JIC 37° Male / Adjustable male
UN/UNF SAE with O-ring 90° elbow.





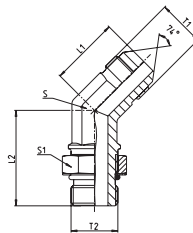

						
ref.	T1	T2	L1	L2	S Flats	S1
JIC	JIC	SAE O	mm	mm	mm	mm
4MJ-4MBA90	7/16-20	7/16-20	23.0	26.0	11.0	14.0
4MJ-6MBA90	7/16-20	9/16-18	27.0	32.0	14.0	17.0
5MJ-5MBA90	1/2-20	1/2-20	24.0	29.0	13.0	17.0
6MJ-6MBA90	9/16-18	9/16-18	27.0	32.0	14.0	17.0
6MJ-4MBA90	9/16-18	7/16-20	27.0	30.0	14.0	14.0
6MJ-8MBA90	9/16-18	3/4-16	29.0	37.0	19.0	22.0
8MJ-8MBA90	3/4-16	3/4-16	32.0	37.0	19.0	22.0
8MJ-10MBA90	3/4-16	7/8-14	34.0	43.0	22.0	27.0
10MJ-10MBA90	7/8-14	7/8-14	37.0	43.0	22.0	27.0
10MJ-12MBA90	7/8-14	1.1/16-12	39.0	49.0	27.0	32.0
12MJ-12MBA90	1.1/16-12	1.1/16-12	42.0	49.0	27.0	32.0
16MJ-16MBA90	1.5/16-12	1.5/16-12	46.0	52.0	33.0	41.0

JIC MJ-MBA45

JIC 37° Male / Adjustable male
UN/UNF SAE with O-ring 45° elbow.



						
ref.	T1	T2	L1	L2	S Flats	S1
JIC	JIC	SAE O	mm	mm	mm	mm
4MJ-4MBA45	7/16-20	7/16-20	18.0	27.0	11.0	14.0
6MJ-6MBA45	9/16-18	9/16-18	21.0	29.0	14.0	17.0
6MJ-8MBA45	9/16-18	3/4-16	22.0	33.0	19.0	22.0
8MJ-8MBA45	3/4-16	3/4-16	25.0	33.0	19.0	22.0
8MJ-6MBA45	3/4-16	9/16-18	25.0	30.0	19.0	17.0
8MJ-10MBA45	3/4-16	7/8-14	25.0	39.0	22.0	25.0
10MJ-10MBA45	7/8-14	7/8-14	28.0	39.0	22.0	27.0
10MJ-8MBA45	7/8-14	3/4-16	28.0	35.0	22.0	22.0
12MJ-12MBA45	1.1/16-12	1.1/16-12	33.0	44.0	27.0	32.0
16MJ-16MBA45	1.5/16-12	1.5/16-12	37.0	47.0	33.0	38.0





JIC ADAPTORS

ISO 8434-2 AND SAE J514

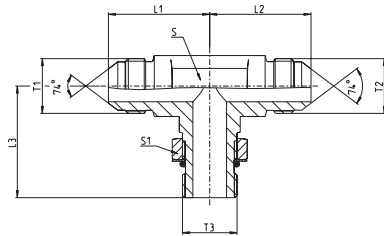
JIC MJ-MJ-MBA

JIC 37° Male / Male / Adjustable male
UN/UNF SAE with O-ring "Branch T".





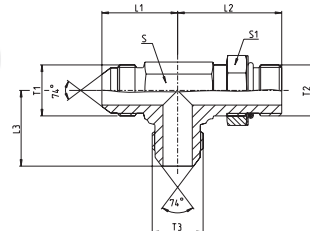

							
ref.	T1	T2	T3	L1 . L2	L3	S Flats	S1
JIC	JIC	JIC	SAE O	mm	mm	mm	mm
4MJ-4MJ-4MBA	7/16-20	7/16-20	7/16-20	23.0	26.0	11.0	14.0
5MJ-5MJ-5MBA	1/2-20	1/2-20	1/2-20	25.0	29.0	14.0	16.0
6MJ-6MJ-6MBA	9/16-18	9/16-18	9/16-18	27.0	32.0	14.0	17.0
8MJ-8MJ-8MBA	3/4-16	3/4-16	3/4-16	22.0	37.0	19.0	22.0
10MJ-10MJ-10MBA	7/8-14	7/8-14	7/8-14	37.0	43.0	22.0	27.0
12MJ-12MJ-12MBA	1.1/16-12	1.1/16-12	1.1/16-12	42.0	49.0	27.0	32.0
16MJ-16MJ-16MBA	1.5/16-12	1.5/16-12	1.5/16-12	46.0	52.0	33.0	27.0

JIC MJ-MBA-MJ

JIC 37° Male / Adjustable male
UN/UNF SAE with O-ring / Male "Run T".



							
ref.	T1	T2	T3	L1 . L3	L2	S Flats	S1
JIC	JIC	SAE O	JIC	mm	mm	mm	mm
4MJ-4MBA-4MJ	7/16-20	7/16-20	7/16-20	23.0	26.0	11.0	14.0
5MJ-5MBA-5MJ	1/2-20	1/2-20	1/2-20	25.0	29.0	14.0	16.0
6MJ-6MBA-6MJ	9/16-18	9/16-18	9/16-18	27.0	32.0	14.0	17.0
8MJ-8MBA-8MJ	3/4-16	3/4-16	3/4-16	22.0	37.0	19.0	22.0
10MJ-10MBA-10MJ	7/8-14	7/8-14	7/8-14	37.0	43.0	22.0	27.0
12MJ-12MBA-12MJ	1.1/16-12	1.1/16-12	1.1/16-12	42.0	49.0	27.0	32.0
16MJ-16MBA-16MJ	1.5/16-12	1.5/16-12	1.5/16-12	46.0	52.0	33.0	27.0

JIC ADAPTORS





ISO 8434-2 AND SAE J514

THE WORLD OF ADAPTORS

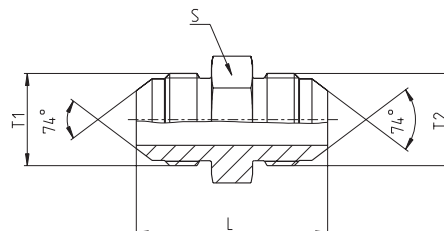
JIC MJ-MJ

JIC 37° Male / Male.





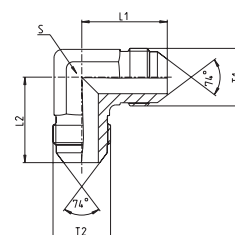

				
ref.	T1	T2	L	S
JIC	JIC	JIC	mm	mm
4MJ-4MJ	7/16-20	7/16-20	35.0	13.0
4MJ-2MJ	7/16-20	5/16-24	32.0	13.0
5MJ-5MJ	1/2-20	1/2-20	35.0	14.0
5MJ-4MJ	1/2-20	7/16-20	35.0	14.0
6MJ-6MJ	9/16-18	9/16-18	36.0	17.0
6MJ-4MJ	9/16-18	7/16-20	36.0	17.0
8MJ-8MJ	3/4-16	3/4-16	41.0	19.0
8MJ-6MJ	3/4-16	9/16-18	39.0	19.0
10MJ-10MJ	7/8-14	7/8-14	48.0	24.0
10MJ-8MJ	7/8-14	3/4-16	45.0	24.0
12MJ-12MJ	1.1/16-12	1.1/16-12	55.0	27.0
16MJ-16MJ	1.5/16-12	1.5/16-12	57.0	36.0

JIC MJ-MJ90

JIC 37° Male / Male 90° elbow.



					
ref.	T1	T2	L1	L2	S Flats
JIC	JIC	JIC	mm	mm	mm
4MJ-4MJ90	7/16-20	7/16-20	23.0	23.0	11.0
5MJ-5MJ90	1/2-20	1/2-20	24.0	24.0	13.0
6MJ-6MJ90	9/16-18	9/16-18	27.0	27.0	14.0
6MJ-4MJ90	9/16-18	7/16-20	27.0	27.0	14.0
8MJ-8MJ90	3/4-16	3/4-16	32.0	32.0	19.0
8MJ-6MJ90	3/4-16	9/16-18	32.0	29.0	19.0
10MJ-10MJ90	7/8-14	7/8-14	37.0	37.0	22.0
10MJ-8MJ90	7/8-14	3/4-16	37.0	34.0	22.0
12MJ-12MJ90	1.1/16-12	1.1/16-12	42.0	42.0	27.0
16MJ-16MJ90	1.5/16-12	1.5/16-12	46.0	46.0	33.0





JIC ADAPTORS

ISO 8434-2 AND SAE J514

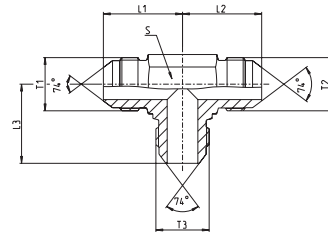
JIC MJ-MJ-MJ

JIC 37° Male / Male / Male "T".





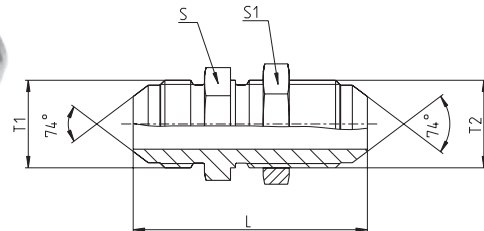

						
ref.	T1	T2	T3	L1 . L2	L3	S Flats
JIC	JIC	JIC	JIC	mm	mm	mm
4MJ-4MJ-4MJ	7/16-20	7/16-20	7/16-20	23.0	23.0	14.0
5MJ-5MJ-5MJ	1/2-20	1/2-20	1/2-20	24.0	24.0	13.0
6MJ-6MJ-6MJ	9/16-18	9/16-18	9/16-18	27.0	27.0	14.0
8MJ-8MJ-8MJ	3/4-16	3/4-16	3/4-16	32.0	32.0	19.0
10MJ-10MJ-10MJ	7/8-14	7/8-14	7/8-14	37.0	37.0	22.0
12MJ-12MJ-12MJ	1.1/16-12	1.1/16-12	1.1/16-12	42.0	42.0	27.0
16MJ-16MJ-16MJ	1.5/16-12	1.5/16-12	1.5/16-12	46.0	46.0	33.0

JIC MJ-MJBKHD

JIC 37° Male / Male bulkhead union with lock nut.



				
ref.	T1	T2	L	S . S1
JIC	JIC	JIC	mm	mm
4MJ-4MJBKHD	7/16-20	7/16-20	53.0	17.0
5MJ-5MJBKHD	1/2-20	1/2-20	53.0	19.0
6MJ-6MJBKHD	9/16-18	9/16-18	55.0	22.0
8MJ-8MJBKHD	3/4-16	3/4-16	62.0	24.0
10MJ-10MJBKHD	7/8-14	7/8-14	70.0	30.0
12MJ-12MJBKHD	1.1/16-12	1.1/16-12	79.0	36.0
16MJ-16MJBKHD	1.5/16-12	1.5/16-12	80.0	41.0

JIC ADAPTORS





ISO 8434-2 AND SAE J514

THE WORLD OF ADAPTORS

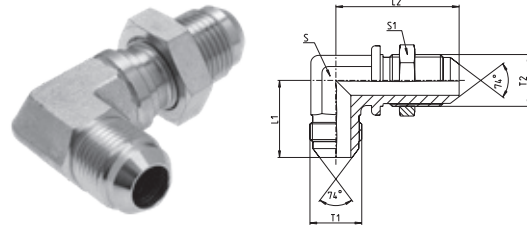
JIC MJ-MJBKHD90

JIC 37° Male / Male bulkhead 90° union elbow with lock nut.





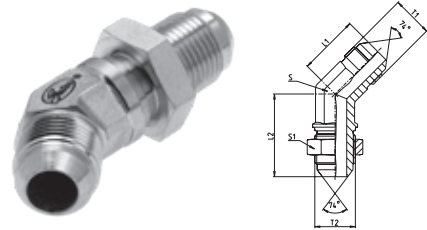

						
ref.	T1	T2	L1	L2	S Flats	S1
JIC	JIC	JIC	mm	mm	mm	mm
4MJ-4MJBKHD90	7/16-20	7/16-20	25.0	40.0	11.0	17.0
5MJ-5MJBKHD90	1/2-20	1/2-20	27.0	44.0	13.0	19.0
6MJ-6MJBKHD90	9/16-18	9/16-18	28.0	46.0	14.0	22.0
8MJ-8MJBKHD90	3/4-16	3/4-16	36.0	54.0	19.0	24.0
10MJ-10MJBKHD90	7/8-14	7/8-14	40.0	61.0	22.0	30.0
12MJ-12MJBKHD90	1.1/16-12	1.1/16-12	45.0	68.0	27.0	36.0
16MJ-16MJBKHD90	1.5/16-12	1.5/16-12	49.0	71.0	33.0	41.0

JIC MJ-MJBKHD45

JIC 37° Male / Male bulkhead 45° union elbow with lock nut.



						
ref.	T1	T2	L1	L2	S Flats	S1
JIC	JIC	JIC	mm	mm	mm	mm
4MJ-4MJBKHD45	7/16-20	7/16-20	18.0	39.0	11.0	17.0
5MJ-5MJBKHD45	1/2-20	1/2-20	20.0	42.0	14.0	19.0
6MJ-6MJBKHD45	9/16-18	9/16-18	21.0	42.0	14.0	22.0
8MJ-8MJBKHD45	3/4-16	3/4-16	25.0	49.0	19.0	24.0
10MJ-10MJBKHD45	7/8-14	7/8-14	28.0	55.0	22.0	30.0
12MJ-12MJBKHD45	1.1/16-12	1.1/16-12	33.0	62.0	27.0	36.0
16MJ-16MJBKHD45	1.5/16-12	1.5/16-12	37.0	65.0	33.0	41.0





JIC ADAPTORS

ISO 8434-2 AND SAE J514

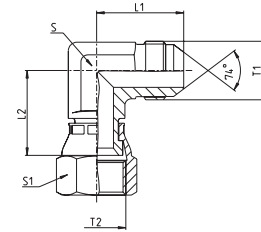
JIC MJ-FJX90

JIC 37° Male / Female swivel 90° elbow.





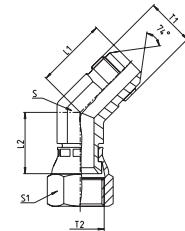

						
ref.	T1	T2	L1	L2	S Flats	S1
JIC	JIC	JIC F	mm	mm	mm	mm
4MJ-4FJX90	7/16-20	7/16-20	23.0	17.0	11.0	14.0
5MJ-5FJX90	1/2-20	1/2-20	24.0	17.0	13.0	17.0
6MJ-6FJX90	9/16-18	9/16-18	27.0	22.0	14.0	19.0
8MJ-8FJX90	3/4-16	3/4-16	32.0	24.0	19.0	22.0
10MJ-10FJX90	7/8-14	7/8-14	37.0	28.0	22.0	27.0
12MJ-12FJX90	1.1/16-12	1.1/16-12	42.0	30.0	27.0	32.0
14MJ-14FJX90	1.3/16-12	1.3/16-12	46.0	34.0	33.0	35.0
16MJ-16FJX90	1.5/16-12	1.5/16-12	46.0	36.0	33.0	38.0

JIC MJ-FJX45

JIC 37° Male / Female swivel 45° elbow.



						
ref.	T1	T2	L1	L2	S Flats	S1
JIC	JIC	JIC F	mm	mm	mm	mm
4MJ-4FJX45	7/16-20	7/16-20	18.0	15.0	11.0	14.0
5MJ-5FJX45	1/2-20	1/2-20	20.0	16.0	14.0	17.0
6MJ-6FJX45	9/16-18	9/16-18	21.0	19.0	14.0	19.0
8MJ-8FJX45	3/4-16	3/4-16	25.0	22.0	19.0	22.0
10MJ-10FJX45	7/8-14	7/8-14	28.0	24.0	22.0	27.0
12MJ-12FJX45	1.1/16-12	1.1/16-12	33.0	24.0	27.0	32.0
16MJ-16FJX45	1.5/16-12	1.5/16-12	37.0	29.0	33.0	38.0

JIC ADAPTORS





ISO 8434-2 AND SAE J514

THE WORLD OF ADAPTORS

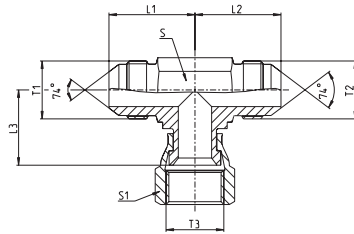
JIC MJ-MJ-FJX

JIC 37° Male / Male / Female swivel
"Branch T".





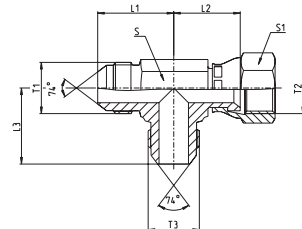

							
ref.	T1	T2	T3	L1 . L2	L3	S Flats	S1
JIC	JIC	JIC	JIC F	mm	mm	mm	mm
4MJ-4MJ-4FJX	7/16-20	7/16-20	7/16-20	23.0	17.0	11.0	14.0
5MJ-5MJ-5FJX	1/2-20	1/2-20	1/2-20	24.0	17.0	13.0	17.0
6MJ-6MJ-6FJX	9/16-18	9/16-18	9/16-18	27.0	22.0	14.0	19.0
8MJ-8MJ-8FJX	3/4-16	3/4-16	3/4-16	32.0	24.0	19.0	22.0
10MJ-10MJ-10FJX	7/8-14	7/8-14	7/8-14	37.0	28.0	22.0	27.0
12MJ-12MJ-12FJX	1.1/16-12	1.1/16-12	1.1/16-12	42.0	38.0	27.0	32.0
16MJ-16MJ-16FJX	1.5/16-12	1.5/16-12	1.5/16-12	46.0	36.0	33.0	38.0

JIC MJ-FJX-MJ

JIC 37° Male / Female Swivel / Male "Run T".



							
ref.	T1	T2	T3	L1 . L3	L2	S Flats	S1
JIC	JIC	JIC F	JIC	mm	mm	mm	mm
4MJ-4FJX-4MJ	7/16-20	7/16-20	7/16-20	23.0	17.0	11.0	14.0
5MJ-5FJX-5MJ	1/2-20	1/2-20	1/2-20	24.0	17.0	13.0	17.0
6MJ-6FJX-6MJ	9/16-18	9/16-18	9/16-18	27.0	22.0	14.0	19.0
8MJ-8FJX-8MJ	3/4-16	3/4-16	3/4-16	32.0	24.0	19.0	22.0
10MJ-10FJX-10MJ	7/8-14	7/8-14	7/8-14	37.0	28.0	22.0	27.0
12MJ-12FJX-12MJ	1.1/16-12	1.1/16-12	1.1/16-12	42.0	38.0	27.0	32.0
14MJ-14FJX-14MJ	1.3/16-12	1.3/16-12	1.3/16-12	46.0	34.0	33.0	35.0
16MJ-16FJX-16MJ	1.5/16-12	1.5/16-12	1.5/16-12	46.0	36.0	33.0	38.0





JIC ADAPTORS

ISO 8434-2 AND SAE J514

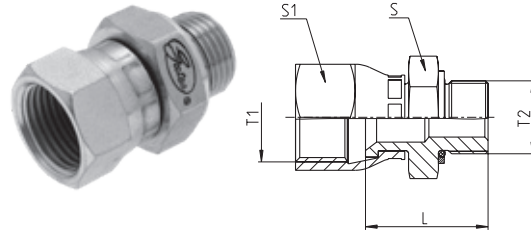
JIC FJX-MBSPPCOR

JIC 37° Female swivel / Male BSPP with O-ring and retaining ring.



					
ref.	T1	T2	L	S	S1 Swivel
JIC	JIC F	BSPP	mm	mm	mm
4FJX-2MBSPPCOR	7/16-20	1/8-28	24.6	17.0	14.0
4FJX-4MBSPPCOR	7/16-20	1/4-19	27.2	19.0	14.0
5FJX-2MBSPPCOR	1/2-20	1/8-28	24.6	16.0	17.0
6FJX-4MBSPPCOR	9/16-18	1/4-19	29.2	19.0	19.0
6FJX-6MBSPPCOR	9/16-18	3/8-19	30.2	22.0	19.0
8FJX-6MBSPPCOR	3/4-16	3/8-19	32.2	22.0	22.0
8FJX-8MBSPPCOR	3/4-16	1/2-14	35.5	30.0	22.0
10FJX-8MBSPPCOR	7/8-14	1/2-14	38.5	30.0	27.0
12FJX-12MBSPPCOR	1.1/16-12	3/4-14	40.5	36.0	32.0
16FJX-16MBSPPCOR	1.5/16-12	1-11	46.6	46.0	38.0
20FJX-20MBSPPCOR	1.5/8-12	1.1/4-11	50.6	50.0	50.0
24FJX-24MBSPPCOR	1.7/8-12	1.1/2-11	54.6	55.0	60.0

JIC ADAPTORS





ISO 8434-2 AND SAE J514

THE WORLD OF ADAPTORS

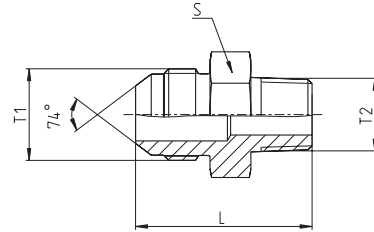
JIC MJ-MP

JIC 37° Male / Male NPT.





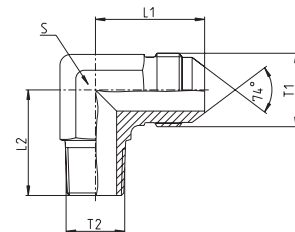

				
ref.	T1	T2	L	S
JIC	JIC	NPT	mm	mm
4MJ-2MP	7/16-20	Z1/8-27	31.0	16.0
4MJ-4MP	7/16-20	Z1/4-18	36.0	14.0
4MJ-6MP	7/16-20	Z3/8-18	37.0	19.0
5MJ-2MP	1/2-20	Z1/8-27	31.0	14.0
5MJ-4MP	1/2-20	Z1/4-18	36.0	14.0
6MJ-4MP	9/16-18	Z1/4-18	36.0	17.0
6MJ-6MP	9/16-18	Z3/8-18	36.0	19.0
6MJ-8MP	9/16-18	Z1/2-14	43.0	22.0
8MJ-6MP	3/4-16	Z3/8-18	39.0	19.0
8MJ-8MP	3/4-16	Z1/2-14	46.0	22.0
8MJ-12MP	3/4-16	Z3/4-14	47.0	27.0
10MJ-8MP	7/8-14	Z1/2-14	48.0	24.0
10MJ-6MP	7/8-14	Z3/8-18	43.0	24.0
10MJ-12MP	7/8-14	Z3/4-14	50.0	27.0
12MJ-12MP	1.1/16-12	Z3/4-14	52.0	27.0
16MJ-16MP	1.5/16-12	Z1-11.5	57.0	36.0

JIC MJ-MP90

JIC 37° Male / Male NPT 90° elbow.



					
ref.	T1	T2	L1	L2	S Flats
JIC	JIC	NPT	mm	mm	mm
4MJ-2MP90	7/16-20	Z1/8-27	23.0	20.0	11.0
4MJ-4MP90	7/16-20	Z1/4-18	27.0	28.0	14.0
6MJ-4MP90	9/16-18	Z1/4-18	27.0	28.0	14.0
6MJ-6MP90	9/16-18	Z3/8-18	29.0	31.0	19.0
6MJ-8MP90	9/16-18	Z1/2-14	31.0	37.0	22.0
8MJ-8MP90	3/4-16	Z1/2-14	34.0	37.0	22.0
10MJ-8MP90	7/8-14	Z1/2-14	37.0	37.0	22.0
12MJ-12MP90	1.1/16-12	Z3/4-14	42.0	40.0	27.0
16MJ-16MP90	1.5/16-12	Z1-11.5	46.0	50.0	33.0





JIC ADAPTORS

ISO 8434-2 AND SAE J514

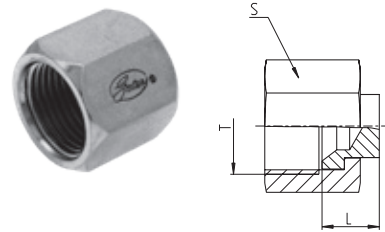
JIC FJ-CAP

JIC 37° Female swivel cap.





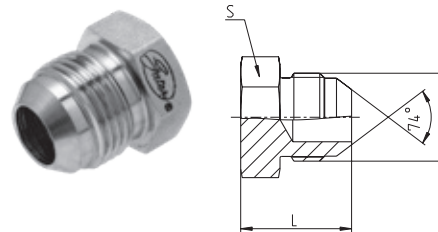

			
ref.	T	L	S
JIC	JIC	mm	mm
4FJ-CAP	7/16-20	9.0	14.0
5FJ-CAP	1/2-20	10.0	17.0
6FJ-CAP	9/16-18	12.0	19.0
8FJ-CAP	3/4-16	14.0	22.0
10FJ-CAP	7/8-14	14.0	27.0
12FJ-CAP	1.1/16-12	17.0	32.0
16FJ-CAP	1.5/16-12	16.0	41.0

JIC MJ-PLUG

JIC 37° Male plug.



			
ref.	T	L	S
JIC	JIC	mm	mm
4MJ-PLUG	7/16-20	20.0	13.0
5MJ-PLUG	1/2-20	20.0	14.0
6MJ-PLUG	9/16-18	21.0	17.0
8MJ-PLUG	3/4-16	24.0	19.0
10MJ-PLUG	7/8-14	28.0	24.0
12MJ-PLUG	1.1/16-12	33.0	27.0
16MJ-PLUG	1.5/16-12	34.0	36.0

JIC ADAPTORS





ISO 8434-2 AND SAE J514

THE WORLD OF ADAPTORS

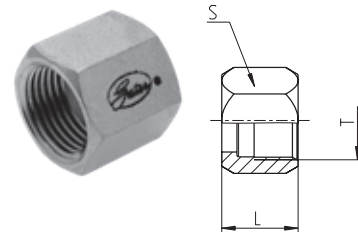
JIC FJ-NUT

JIC 37° Female nut.





			
ref.	T	L	S
JIC	JIC	mm	mm
4FJ-NUT	7/16-20	15.8	14.0
5FJ-NUT	1/2-20	17.3	17.0
6FJ-NUT	9/16-18	18.5	19.0
8FJ-NUT	3/4-16	21.6	22.0
10FJ-NUT	7/8-14	24.9	27.0
12FJ-NUT	1.1/16-12	26.2	32.0
16FJ-NUT	1.5/16-12	28.7	41.0
20FJ-NUT	1.5/8-12	31.2	50.0
24FJ-NUT	1.7/8-12	36.1	60.0

JIC TS METRIC

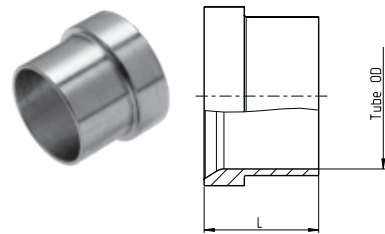
JIC 37° Tube end sleeve for metric tubes.



		
ref.	Tube OD	L
JIC	mm	mm
6TS	6	10.4
8TS	8	11.2
10TS	10	12.7
12TS	12	14.2
16TS	16	16.8
20TS	20	17.3
25TS	25	19.8
30TS	30	23.1
38TS	38	28.4



JIC ADAPTORS

ISO 8434-2 AND SAE J514

JIC TS IMPERIAL

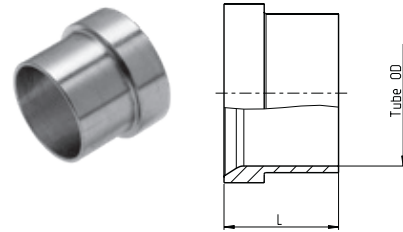
JIC 37° Tube end sleeve for imperial tubes.





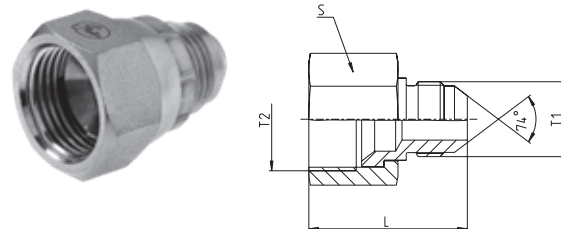

		
ref.	Tube OD	L
JIC	mm	mm
TS04	1/4	10.4
TS05	5/16	11.2
TS06	3/8	12.7
TS08	1/2	14.2
TS10	5/8	16.8
TS12	3/4	17.3
TS16	1	19.8

JIC FJX-MJ

JIC 37° Female swivel / Male tube reducer.



			
ref.	T2	T1	L
JIC	JIC F	JIC	mm
6FJX-4MJ	9/16-18	7/16-20	23.0
8FJX-6MJ	3/4-16	9/16-18	23.0
10FJX-4MJ	7/8-14	7/16-20	26.0
10FJX-6MJ	7/8-14	9/16-18	29.0
10FJX-8MJ	7/8-14	3/4-16	22.0
12FJX-4MJ	1.1/16-12	7/16-20	28.0
12FJX-8MJ	1.1/16-12	3/4-16	27.0
12FJX-10MJ	1.1/16-12	7/8-14	26.0
16FJX-6MJ	1.5/16-12	9/16-18	31.0
16FJX-10MJ	1.5/16-12	7/8-14	30.0
16FJX-12MJ	1.5/16-12	1.1/16-12	35.0
24FJX-16MJ	1.7/8-12	1.5/16-12	41.0

THE WORLD OF ADAPTORS
INTEGRATED FLUID POWER SOLUTIONS



QLH ADAPTORS

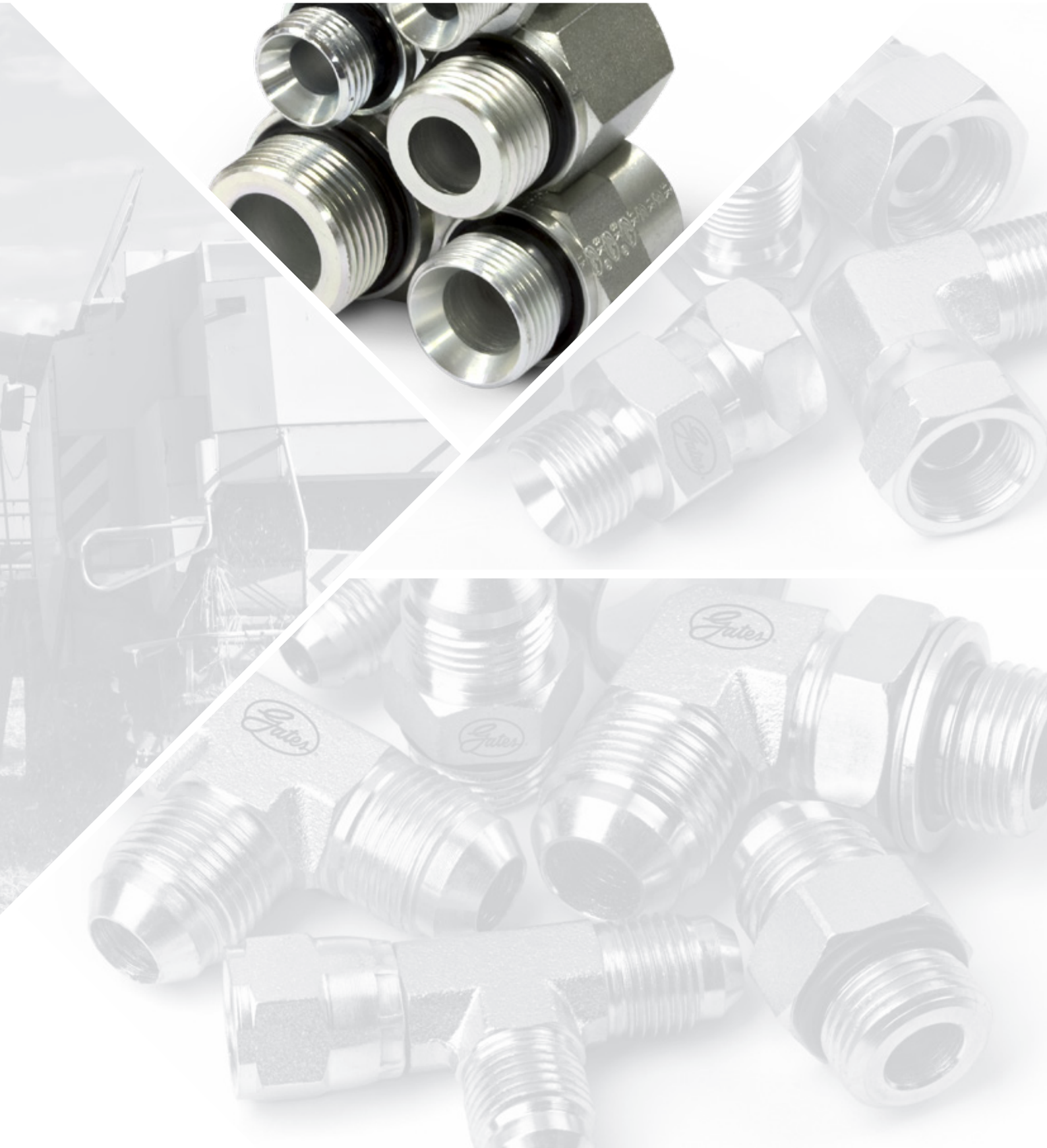





QLH ADAPTORS

THE WORLD OF ADAPTORS

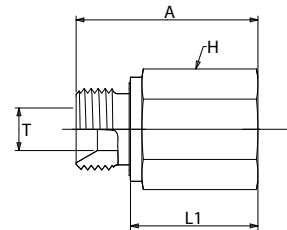
BSP MBSPP-FQLH

Quick-Lok™ High adaptor BSP MBSPP to QLH.
Male BSP thread with captive seal. 60° cone.
DIN 3852-11 form E. ISO 1179-2.





QLH						
		A	L1	H	T	
		mm	mm	mm	mm	REF.
4FQLH	G1/4" - 19 BSP	44.5	32.5	22.0	4.7	4FQLH-4MBSPPCSC
4FQLH	G3/8" - 19 BSP	44.5	32.5	22.0	7.0	4FQLH-6MBSPPCSC
6FQLH	G1/4" - 19 BSP	44.2	32.2	22.0	4.7	6FQLH-4MBSPPCSC
6FQLH	G3/8" - 19 BSP	44.7	32.7	22.0	8.2	6FQLH-6MBSPPCSC
6FQLH	G1/2" - 14 BSP	47.0	33.0	27.0	10.0	6FQLH-8MBSPPCSC
6FQLH	G3/4" - 14 BSP	49.2	33.2	32.0	11.0	6FQLH-12MBSPPCSC
8FQLH	G3/8" - 19 BSP	44.7	32.7	24.0	8.2	8FQLH-6MBSPPCSC
8FQLH	G1/2" - 14 BSP	47.0	33.0	27.0	11.0	8FQLH-8MBSPPCSC
8FQLH	G3/4" - 14 BSP	49.0	33.0	32.0	10.0	8FQLH-12MBSPPCSC
10FQLH	G1/2" - 14 BSP	47.0	33.0	27.0	11.0	10FQLH-8MBSPPCSC
10FQLH	G3/4" - 14 BSP	49.0	33.0	32.0	15.0	10FQLH-12MBSPPCSC
12FQLH	G1/2" - 14 BSP	47.2	33.2	32.0	11.2	12FQLH-8MBSPPCSC
12FQLH	G3/4" - 14 BSP	49.2	33.2	36.0	16.7	12FQLH-12MBSPPCSC
12FQLH	G1" - 11 BSP	51.2	33.2	41.0	21.0	12FQLH-16MBSPPCSC
16FQLH	G3/4" - 14 BSP	49.2	33.2	41.0	16.7	16FQLH-12MBSPPCSC
16FQLH	G1" - 11 BSP	51.0	33.0	41.0	22.2	16FQLH-16MBSPPCSC

BSP MBSPPBKHD-FQLH

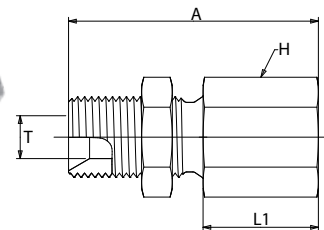
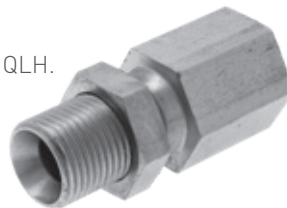
Quick-Lok™ High adaptor BSP MBSPPBKHD to QLH.
Male BSP thread. Bulkhead. 60° cone.







QLH						
		A	L1	H	T	
		mm	mm	mm	mm	REF.
4FQLH	G1/4" - 19 BSP	62.0	30.0	19.0	4.7	4FQLH-4MBSPPBKHD
6FQLH	G3/8" - 19 BSP	62.0	30.0	22.0	8.2	6FQLH-6MBSPPBKHD
8FQLH	G1/2" - 14 BSP	65.0	30.0	27.0	11.0	8FQLH-8MBSPPBKHD
12FQLH	G3/4" - 14 BSP	68.0	30.0	36.0	16.7	12FQLH-12MBSPPBKHD
16FQLH	G1" - 11 BSP	71.0	30.0	41.0	22.2	16FQLH-16MBSPPBKHD

QLH ADAPTORS

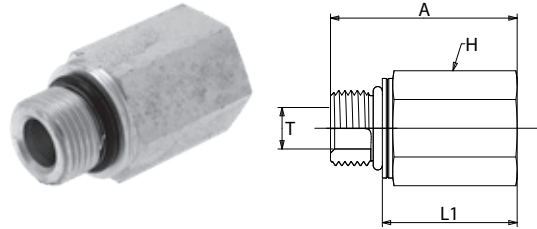
DIN MMOR-FQLH

Quick-Lok™ High adaptor DIN MMOR to QLH.
Male metric thread with O-ring. ISO 6149-2, -3.





QLH						
		A	L1	H	T	REF.
		mm	mm	mm	mm	FQLH
4FQLH	M12x1.5	43.5	32.5	19.0	6.0	4FQLH-12MMOR
4FQLH	M14x1.5	43.5	32.5	22.0	7.0	4FQLH-14MMOR
6FQLH	M14x1.5	43.5	32.5	22.0	7.0	6FQLH-14MMOR
6FQLH	M16x1.5	45.0	32.5	22.0	9.0	6FQLH-16MMOR
6FQLH	M18x1.5	45.0	32.5	24.0	10.0	6FQLH-18MMOR
8FQLH	M18x1.5	45.0	32.5	24.0	10.0	8FQLH-18MMOR
8FQLH	M22x1.5	45.5	32.5	27.0	10.0	8FQLH-22MMOR
10FQLH	M22x1.5	45.5	32.5	27.0	14.0	10FQLH-22MMOR
12FQLH	M26x1.5	48.5	32.5	32.0	14.0	12FQLH-26MMOR
12FQLH	M27x2	48.5	32.5	32.0	18.0	12FQLH-27MMOR
16FQLH	M33x2	48.5	32.5	41.0	23.0	16FQLH-33MMOR

SAE MB-FQLH

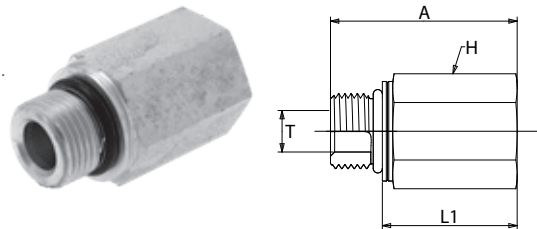
Quick-Lok™ High adaptor SAE MB 'Heavy Duty' to QLH.
SAE J1926-2. ISO 11926-2.



QLH						
		A	L1	H	T	REF.
		mm	mm	mm	mm	FQLH
4FQLH	7/16" - 20 UNF	42.0	31.0	19.0	4.0	4FQLH-4MB
4FQLH	9/16" - 18 UNF	42.0	30.0	19.0	6.8	4FQLH-6MB
6FQLH	7/16" - 20 UNF	42.0	31.0	22.0	4.5	6FQLH-4MB
6FQLH	9/16" - 18 UNF	43.0	31.0	22.0	7.5	6FQLH-6MB
6FQLH	3/4" - 16 UNF	43.0	29.0	24.0	10.0	6FQLH-8MB
8FQLH	9/16" - 18 UNF	43.5	31.5	24.0	7.5	8FQLH-6MB
8FQLH	3/4" - 16 UNF	44.5	30.5	24.0	10.0	8FQLH-8MB
8FQLH	7/8" - 14 UNF	46.0	30.0	27.0	12.7	8FQLH-10MB
10FQLH	3/4" - 16 UNF	47.0	33.0	27.0	10.0	10FQLH-8MB
10FQLH	7/8" - 14 UNF	47.0	31.0	27.0	12.7	10FQLH-10MB
10FQLH	1.1/16" - 12 UN	48.0	29.5	32.0	14.3	10FQLH-12MB
12FQLH	7/8" - 14 UNF	48.0	32.0	32.0	12.7	12FQLH-10MB
12FQLH	1.1/16" - 12 UN	50.0	31.5	32.0	15.5	12FQLH-12MB
12FQLH	1.5/16" - 12 UN	50.0	31.5	41.0	19.8	12FQLH-16MB
16FQLH	1.5/16" - 12 UN	50.0	31.5	41.0	21.0	16FQLH-16MB



INTEGRATED FLUID POWER SOLUTIONS

THE WORLD OF TUBE FITTINGS



SAFETY OF ENVIRONMENT COMBINED WITH OPTIMAL CORROSION PROTECTION

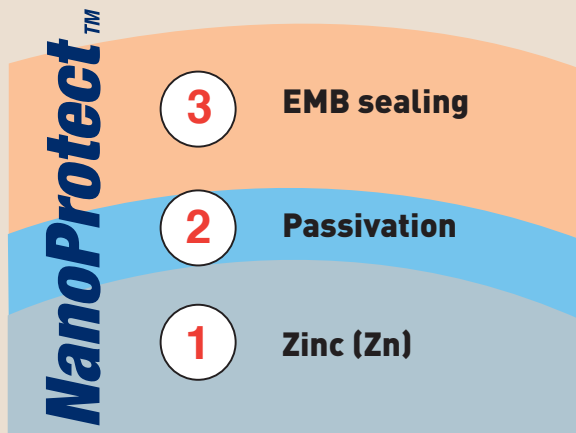

NanoProtect™ is the innovative chrome(VI)-free surface protection for hydraulic fittings that provides a much better corrosion protection than the previous Cr(VI)-containing passivation.

The highest form of safeguard

The NanoProtect™ innovative surface protection is the result of intensive research & development in electroplating technology and extensive tests in laboratories as well as in the field. The optimised passivation method results in a new, superior type of corrosion resistance against white and red rust that protects against damage during handling and assembly as well.

Triple safety with the NanoProtect™-hydraulic fittings

NanoProtect™ is an extremely economical and future-orientated solution for the rough every-day application in stationary and mobile hydraulics as well as in compressed air technology thanks to the triple layer design: the first layer consists of zinc, the second layer is a Cr(VI)-free passivation and the third layer is the sealing. This surface layer is 9 to 14 µm thick and offers a high degree of resilience with resistance against hydraulic media. Its friction coefficient is lower than that of the usual A3L surfaces which means that the assembly forces are reduced and that the risk of a faulty assembly is minimised. No use of oil is necessary.

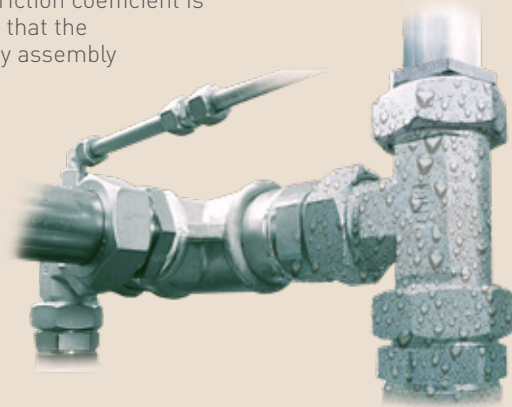

High-grade hydraulic fittings with an optimised cost-benefit ratio and enhanced durability

The ultimate chrome(VI)-free surface protection



Spare the environment and reduce recycling costs at the same time



With our quality-assured and resources-saving production process, we strive to care for the environment. The new Cr(VI) and nickel free NanoProtect™ surface helps you to protect the resources during all levels of the production process – and it is compliant with the EU old vehicles directive 2000/53/EG and the EU Directive 2002/95/EG (RoHS) on restriction of the use of certain hazardous substances in electrical and electronic equipment. With this technology, users in mechanical engineering and in mobile hydraulics are able to use a surface technology which is environmentally friendly and helps you to cut recycling costs.

ATTENTION

TUBE FITTINGS SELECTION TABLE

THE WORLD OF TUBE FITTINGS

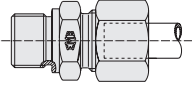
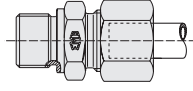
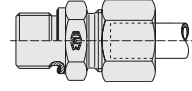
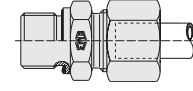
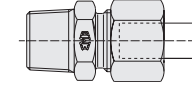
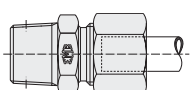
PIPE SCREW JOINTS/SCREW IN SCREW JOINTS/ SCREW JOINT PIPE CONNECTIONS

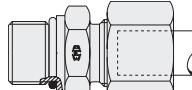
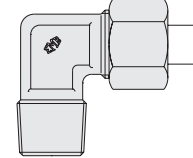
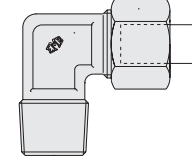
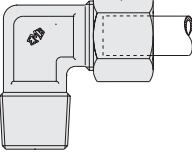
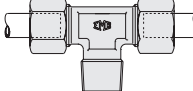
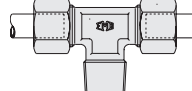
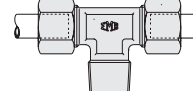
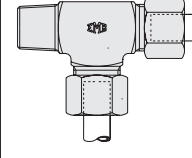
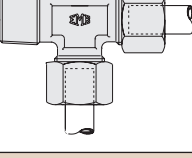
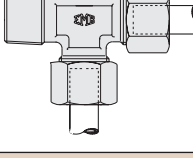
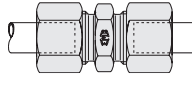
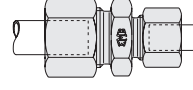
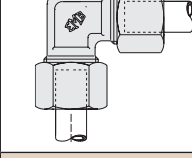
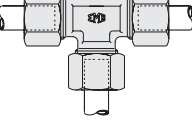
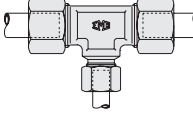
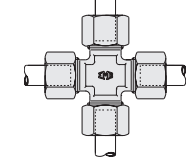
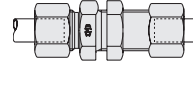
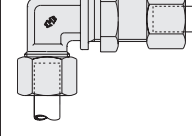
A				
				
A Male stud coupling BSP p. 368	A Male stud coupling Metric p. 370	A Male stud coupling BSP WD p. 371	A Male stud coupling Metric WD p. 372	A Male stud coupling NPT p. 373
A			B	
				
A Male stud coupling BSP Taper p. 374	A Male stud coupling Metric O-ring p. 375	A Male stud coupling UNF/UN p. 376	B Male stud elbow BSP taper p. 377	B Male stud elbow Metric taper p. 378
B	C			D
				
B Male stud elbow NPT p. 379	C Male stud coupling BSP Taper p. 380	C Male stud coupling Metric Taper p. 381	C Male stud coupling NPT p. 382	D Male stud run tee BSP taper p. 383
D	E	ER	F	
				
D Male stud run tee Metric taper p. 384	D Male stud run tee NPT p. 385	E Straight couplings p. 386	ER Straight reducing couplings p. 387	F Equal elbows p. 388
G	GR	H	K	L
				
G Equal tees p. 389	GR Tee reducers p. 390	H Equal crosses p. 392	K Straight bulkhead connections p. 393	L Bulkhead elbow connections p. 394

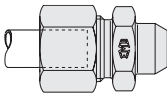
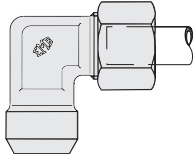
N	V	BS
		
N Welding bulkhead connections p. 395	V Welding bosses p. 396	BS Welding elbows p. 397

COUPLINGS

Banjo coupling

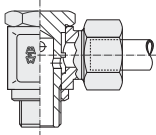
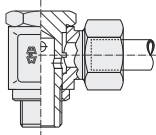
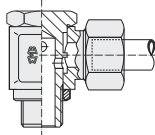
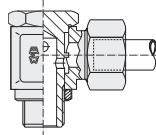
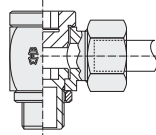
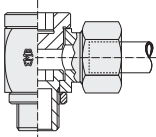
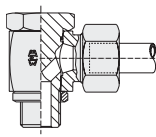
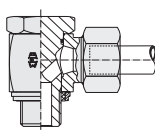
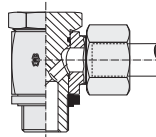
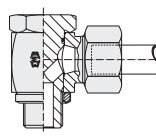
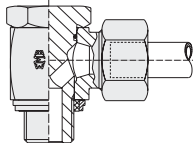
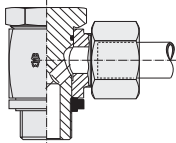
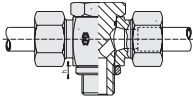
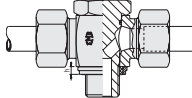
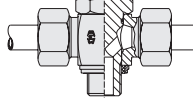
SBD				SB
				
SBD Banjo coupling BSP p. 400	SBD Banjo coupling Metric p. 401	SBD Banjo coupling components BSP p. 402	SBD Banjo coupling components Metric p. 403	SB Banjo coupling choke-free BSP p. 404
SB	SBE			
				
SB Banjo coupling choke-free Metric p. 405	SBE Banjo coupling high pressure Metric DKA p. 406	SBE Banjo coupling high pressure BSP EDE p. 407	SBE Banjo coupling high pressure BSP KDE p. 408	SBE Banjo coupling high pressure Metric DKA p. 409
SBE		SGE		
				
SBE Banjo coupling high pressure Metric EDE p. 410	SBE Banjo coupling high pressure Metric KDE p. 411	SGE T swiveling screw fitting high pressure BSP DKA p. 412	SGE T swiveling screw fitting high pressure BSP EDE p. 413	SGE T swiveling screw fitting high pressure Metric DKA p. 414

TUBE FITTINGS SELECTION TABLE

THE WORLD OF TUBE FITTINGS

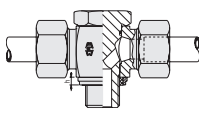
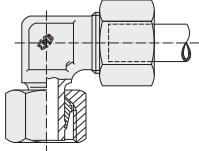
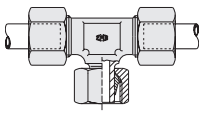
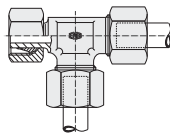
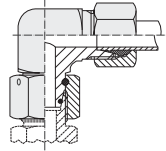

Adjustable coupling

SGE	VB	VC	VD	VBDKO
				
SGE T swiveling screw fitting high pressure Metric EDE p. 415	VB Adjustable elbow p. 416	VC Adjustable branch tee p. 417	VD Adjustable barrel tee p. 418	VBDKO Adjustable male stud elbow p. 419

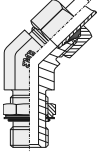
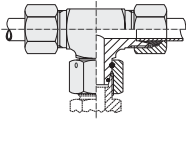
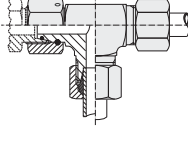
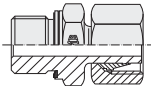
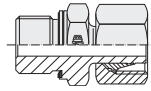
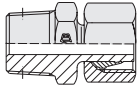
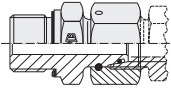
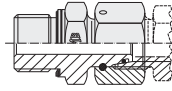
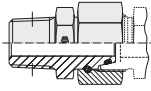
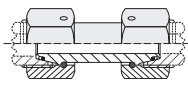
Standpipe coupling

BFDKO	VCDKO	VDDKO	VA	
				
BFDKO Adjustable 45° elbow p. 420	VCDKO Adjustable equal tee p. 421	VDDKO Adjustable male stud tee-stud barrel p. 422	VA Stud standpipe coupling BSP p. 423	VA Stud standpipe coupling Metric p. 424
VA	VADKO			EDKO
				
VA Stud standpipe coupling NPT p. 425	VADKO Stud standpipe adaptor BSP p. 426	VADKO Stud standpipe adaptor Metric p. 427	VADKO Stud standpipe adaptor NPT p. 428	EDKO Straight coupling taper p. 429

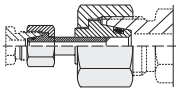
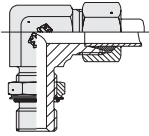
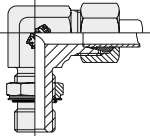
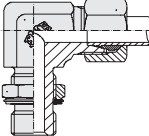
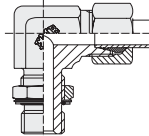
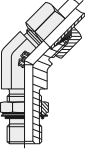
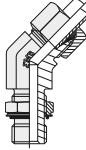
Adjustable locknut coupling

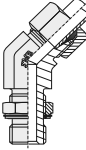
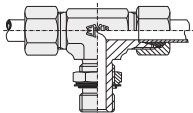
EDKOR	BE			
				
EDKOR Straight reducer coupling taper p. 430	BE Adjustable locknut elbow Metric p. 432	BE Adjustable locknut elbow UNF/UN p. 433	BE Adjustable locknut elbow BSP RR p. 434	BE Adjustable locknut elbow Metric RR p. 435
BFE				CE
				
BFE Adjustable 45° locknut elbow Metric p. 436	BFE Adjustable 45° locknut elbow UNF/UN p. 437	BFE Adjustable 45° locknut elbow BSP RR p. 438	BFE Adjustable 45° locknut elbow Metric RR p. 439	CE Adjustable locknut branch tee Metric p. 440

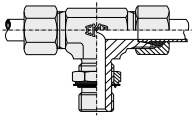
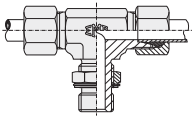
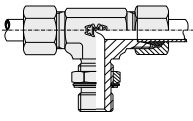
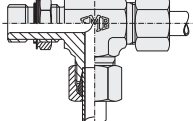
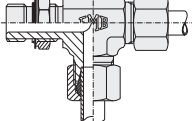

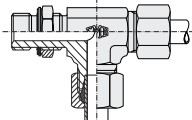
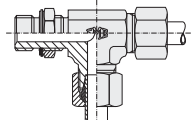
CE			DE	
				
CE Adjustable locknut branch tee UNF/UN p. 441	CE Adjustable locknut branch tee BSP RR p. 442	CE Adjustable locknut branch tee Metric RR p. 443	DE Adjustable locknut run tee Metric p. 444	DE Adjustable locknut run tee UNF/UN p. 445

DE	
	
DE Adjustable locknut run tee BSP RR p. 446	DE Adjustable locknut run tee Metric RR p. 447

PIPE CONNECTION / PRESSURE-GAUGE CONNECTION / CONNECTIONS REDUCER

Gauge Couplings

Female stud couplings

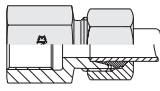
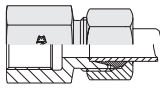
O	VODKO	AI	
			
O Gauge coupling BSP p. 450	VODKO Gauge coupling p. 451	AI Female stud coupling BSP p. 452	AI Female stud coupling Metric p. 453

Reducing adaptors

Reducing connections

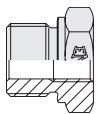
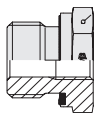
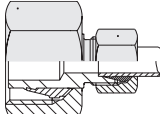
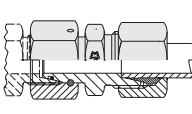
RI	RI/WD	RL/RS	RLDKO/RSDKO
			
RI Reducing adaptor BSP p. 454	RI/WD Reducing adaptor BSP p. 455	RL/RS Reducing connection p. 456-457	RLDKO/RSDKO Reducing connection p. 458-459

TUBE FITTINGS SELECTION TABLE

THE WORLD OF TUBE FITTINGS

VALVES / NON-RETURN VALVES / SHUT-OFF ELEMENTS

Non-return valves with cone

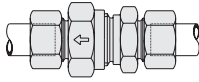
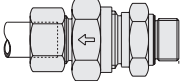
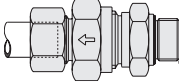
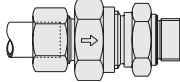
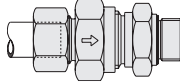
RD	RV		RZ	
				
RD Non-return valves p. 463	RV Non-return valves BSP p. 464	RV Non-return valves Metric p. 465	RZ Non-return valves BSP p. 466	RZ Non-return valves Metric p. 467

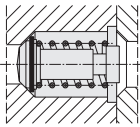
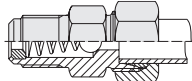
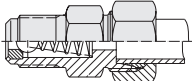

Ball check valves

RF	RVS	ARVA	ARVV
			
RF Non-return valves p. 468	RVS Inside parts p. 468	ARVA Ball check valves p. 469	ARVV Ball check valves p. 469

SINGLE PARTS

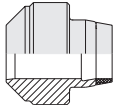
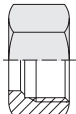
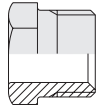

Cutting Ring

Nut



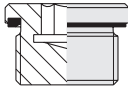
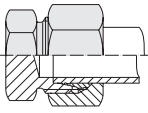
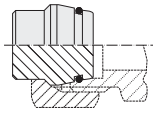

DS	DSW	M	UES	GM
				
DS Cutting Ring p. 472	DSW Cutting Ring p. 473	M Coupling nut p. 474	UES Internal coupling nut p. 475	GM Counter nut p. 475

Plug

Sealing Ring

VSCH	VSCHK	STO	DKA/DKAD	DKI
				
VSCH Blanking plug p. 476	VSCHK Standpipe end plug p. 477	STO Blanking plug p. 478	DKA/DKAD Sealing Ring p. 479-480	DKI Packing ring p. 481

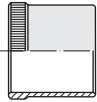

Support Sleeve

WD	TR	KDE	EDE	VSH
				
WD Captive seal p. 481	TR Sealing Ring p. 482	KDE Retaining ring p. 483	EDE Retaining ring with captive seal p. 484	VSH Support Sleeve p. 485

WELDING NIPPLE-PIPE SCREW JOINTS

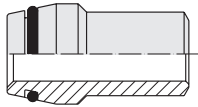
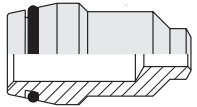
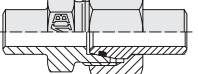

Welding nipples

Welding type screw joints

SNO	SNR	SNO-V	SNO-A
			
SNO Welding nipple p. 488	SNR Welding nipple reducer p. 489	SNO-V Welding type screw joint p. 490	SNO-A Welding type order example p. 491

FLARE COUPLINGS

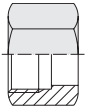
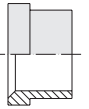
Flare connection parts

BAO	BMO	SRO	ABO-A
			
BAO Flare adaptor p. 495	BMO Nut p. 495	SRO Support ring p. 495	Flaring type order example p. 496







TUBE FITTINGS SELECTION TABLE

THE WORLD OF TUBE FITTINGS

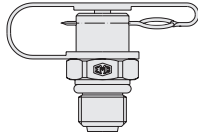
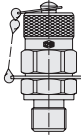
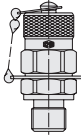
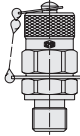
CONTROL SYSTEM

Test Couplings

Accessories

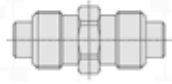
CST	CSH	CSS	CSHK	CST
				
CST Test coupling 400 bar p. 500-503	CSH Test coupling 630 bar p. 504-510	CSS Test coupling 630 bar p. 511-517	CSHK Test coupling 630 bar p. 518-521	CST Pressure test kit p. 522
CSH	CSS	CMM	VO	CS
				
CSH Pressure test kit p. 522	CSS Pressure test kit p. 522	CMM Pressure gauge p. 523	VO Adjustable gauge fitting p. 523	CS Hose connector p. 524

HOSE FITTING



Hose fitting
p. 525-533

THE WORLD OF TUBE FITTINGS
INTEGRATED FLUID POWER SOLUTIONS



PIPE SCREW JOINTS



PIPE SCREW JOINTS A MALE STUD COUPLINGS

THE WORLD OF TUBE FITTINGS

A MALE STUD COUPLING BSP

Series LL, BSP taper.

Series L+S, BSP parallel, form B.

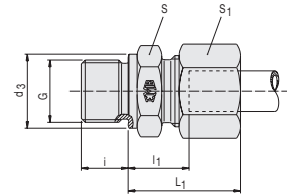

description	pipe OD	PN series	S	S ₁	L ₁	l ₁	d ₃	i	G	kg / 100 pcs
A 4-RLL	4	LL 100 (400)	11	10	26.0	16.0	-	8	R 1/8" K taper	1.4
A 6-RLL	6	LL PN 100 (400)	11	12	26.0	14.5	-	8	R 1/8" K taper	1.6
A 8-RLL	8	LL PN 100 (400)	12	14	28.0	16.5	-	8	R 1/8" K taper	1.8
DS-A 6-RL	6	L PN 400 (1600)	14	14	23.0	8.5	14	8	G 1/8" A	2.5
DS-A 6-L/R 1/4"	6	L PN 400 (1600)	19	14	25.0	10.0	18	12	G 1/4" A	3.5
DS-A 6-L/R 3/8"	6	L PN 400 (1600)	22	14	26.0	11.5	22	12	G 3/8" A	5.6
DS-A 6-L/R 1/2"	6	L PN 400 (1600)	27	14	27.0	12.0	26	14	G 1/2" A	7.3
DS-A 8-RL	8	L PN 400 (1600)	19	17	25.0	10.0	18	12	G 1/4" A	4.5
DS-A 8-L/R 1/8"	8	L PN 400 (1600)	14	17	24.0	9.5	14	8	G 1/8" A	3.1
DS-A 8-L/R 3/8"	8	L PN 400 (1600)	22	17	26.0	11.5	22	12	G 3/8" A	6.0
DS-A 8-L/R 1/2"	8	L PN 400 (1600)	27	17	27.0	12.0	26	14	G 1/2" A	9.0
DS-A 10-RL	10	L PN 400 (1600)	19	19	26.0	11.0	18	12	G 1/4" A	4.7
DS-A 10-L/R 3/8"	10	L PN 400 (1600)	22	19	27.0	12.5	22	12	G 3/8" A	6.2
DS-A 10-L/R 1/2"	10	L PN 400 (1600)	27	19	28.0	13.0	26	14	G 1/2" A	9.2
DS-A 12-RL	12	L PN 400 (1600)	22	22	27.0	12.5	22	12	G 3/8" A	7.0
DS-A 12-L/R 1/4"	12	L PN 400 (1600)	19	22	27.0	12.0	18	12	G 1/4" A	5.8
DS-A 12-L/R 1/2"	12	L PN 400 (1600)	27	22	28.0	13.0	26	14	G 1/2" A	9.4
DS-A 12-L/R 3/4"	12	L PN 400 (1600)	32	22	29.0	14.0	32	16	G 3/4" A	14.7
DS-A 15-RL	15	L PN 400 (1600)	27	27	29.0	14.0	26	14	G 1/2" A	11.5
DS-A 15-L/R 3/8"	15	L PN 400 (1600)	24	27	29.0	13.5	22	12	G 3/8" A	9.7
DS-A 15-L/R 3/4"	15	L PN 400 (1600)	32	27	30.0	15.0	32	16	G 3/4" A	16.1
DS-A 18-RL	18	L PN 400 (1600)	27	32	31.0	14.5	26	14	G 1/2" A	13.2
DS-A 18-L/R 3/8"	18	L PN 400 (1600)	27	32	29.5	14.0	22	12	G 3/8" A	13.3
DS-A 18-L/R 3/4"	18	L PN 400 (1600)	32	32	30.0	14.5	32	16	G 3/4" A	17.3

L₁ = approximate length with nut tightened

Please see "Engineering and technical data - Selecting the correct tube fitting" for more information on pressure.

PIPE SCREW JOINTS A MALE STUD COUPLINGS

description	pipe OD	PN/PB series	S	S ₁	L ₁	l ₁	d ₃	i	G	kg / 100 pcs
DS-A 22-RL	22	L PN 250 (1000)	32	36	33	16.5	32	16	G 3/4" A	18.5
DS-A 22-L/R 1/2"	22	L PN 250 (1000)	32	36	47	26.5	26	14	G 1/2" A	17.7
DS-A 28-RL	28	L PN 250 (1000)	41	41	34	17.5	39	18	G 1" A	25.9
DS-A 28-L/R 3/4"	28	L PB 250 (625)	41	41	34	17.5	32	16	G 3/4" A	25.6
DS-A 35-RL	35	L PB 250 (625)	50	50	39	17.5	49	20	G 1 1/4" A	42.2
DS-A 35-L/R 1"	35	L PB 250 (625)	46	50	39	17.5	39	18	G 1" A	37.8
DS-A 42-RL	42	L PB 250 (625)	55	60	42	19.0	55	22	G 1 1/2" A	56.9
DS-A 6-RS	6	S PB 630 (1575)	19	17	28	13.0	18	12	G 1/4" A	5.0
DS-A 6-S/R 1/2"	6	S PB 630 (1575)	27	17	33	18.0	26	14	G 1/2" A	10.8
DS-A 8-RS	8	S PB 630 (1575)	19	19	30	15.0	18	12	G 1/4" A	5.5
DS-A 8-S/R 3/8"	8	S PB 630 (1575)	22	19	30	15.5	22	12	G 3/8" A	8.0
DS-A 10-RS	10	S PB 630 (1575)	22	22	31	15.0	22	12	G 3/8" A	8.8
DS-A 10-S/R 1/4"	10	S PB 630 (1575)	19	22	31	14.5	18	12	G 1/4" A	7.5
DS-A 10-S/R 1/2"	10	S PB 630 (1575)	27	22	34	17.5	26	14	G 1/2" A	12.9
DS-A 12-RS	12	S PB 630 (1575)	22	24	33	17.0	22	12	G 3/8" A	10.0
DS-A 12-S/R 1/4"	12	S PB 630 (1575)	22	24	33	16.5	18	12	G 1/4" A	9.3
DS-A 12-S/R 1/2"	12	S PB 630 (1575)	27	24	34	17.5	26	14	G 1/2" A	13.3
DS-A 14-RS	14	S PB 630 (1575)	27	27	37	19.0	26	14	G 1/2" A	14.8
DS-A 14-S/R 3/8"	14	S PB 630 (1575)	24	27	36	18.5	22	12	G 3/8" A	12.8
DS-A 16-RS	16	S PB 630 (1575)	27	30	37	18.5	26	14	G 1/2" A	16.1
DS-A 16-S/R 3/8"	16	S PB 630 (1575)	27	30	36	18.0	22	12	G 3/8" A	15.3
DS-A 16-S/R 3/4"	16	S PB 400 (1000)	32	30	39	20.5	32	16	G 3/4" A	22.6
DS-A 20-RS	20	S PB 400 (1000)	32	36	42	20.5	32	16	G 3/4" A	25.3
DS-A 20-S/R 1/2"	20	S PB 400 (1000)	32	36	42	20.5	26	14	G 1/2" A	24.3
DS-A 25-RS	25	S PB 400 (1000)	41	46	47	23.0	39	18	G 1" A	48.7
DS-A 25-S/R 3/4"	25	S PB 400 (1000)	41	46	47	23.0	32	16	G 3/4" A	46.5
DS-A 30-RS	30	S PB 250 (625)	50	50	50	23.5	49	20	G 1 1/4" A	66.3
DS-A 30-S/R 1"	30	S PB 250 (625)	46	50	50	23.5	39	18	G 1" A	57.8
DS-A 38-RS	38	S PB 250 (625)	55	60	57	26.0	55	22	G 1 1/2" A	90.1
DS-A 38-S/R 1 1/4"	38	S PB 250 (625)	55	60	57	26.0	49	20	G 1 1/4" A	91.9

L₁ = approximate length with nut tightened

Please see "Engineering and technical data - Selecting the correct tube fitting" for more information on pressure.

PIPE SCREW JOINTS A MALE STUD COUPLINGS

THE WORLD OF TUBE FITTINGS

A MALE STUD COUPLING METRIC

Series LL, metric taper.

Series L+S, metric parallel, form B.

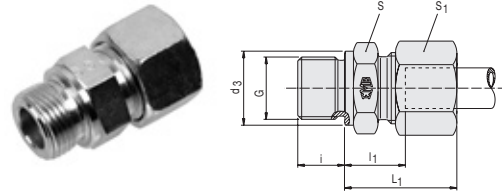

description	pipe OD	PN/PB series	S	S ₁	L ₁	l ₁	d ₃	i	G	kg / 100 pcs
A 4-MLL	4	LL PN 100 (400)	10	10	25	16.0	-	8	M 8 x 1 K	1.4
A 4-LL/M 6 x 1	4	LL PN 100 (400)	9	10	26	16.0	-	8	M 6 x 1 K	0.9
A 6-MLL	6	LL PN 100 (400)	11	12	25	14.5	-	8	M 10 x 1 K	1.6
A 8-MLL	8	LL PN 100 (400)	12	14	27	16.5	-	8	M 10 x 1 K	1.8
DS-A 6-ML	6	L PN 400 (1600)	14	14	23	8.5	14	8	M 10 x 1	2.5
DS-A 8-ML	8	L PN 400 (1600)	17	17	25	10.0	17	12	M 12 x 1.5	4.0
DS-A 8-L/M 18 x 1.5	8	L PN 400 (1600)	24	17	26	11.5	23	12	M 18 x 1.5	6.7
DS-A 10-ML	10	L PN 400 (1600)	19	19	26	11.0	19	12	M 14 x 1.5	4.9
DS-A 10-L/M 16 x 1.5	10	L PN 400 (1600)	22	19	27	12.0	21	12	M 16 x 1.5	6.0
DS-A 10-L/M 18 x 1.5	10	L PN 400 (1600)	24	19	27	12.5	23	12	M 18 x 1.5	7.0
DS-A 10-L/M 22 x 1.5	10	L PN 400 (1600)	27	19	29	14.0	27	14	M 22 x 1.5	9.2
DS-A 12-ML	12	L PN 400 (1600)	22	22	27	12.5	21	12	M 16 x 1.5	6.8
DS-A 12-L/M 14 x 1.5	12	L PN 400 (1600)	19	22	26	11.0	19	12	M 14 x 1.5	5.7
DS-A 12-L/M 18 x 1.5	12	L PN 400 (1600)	24	22	27	12.5	23	12	M 18 x 1.5	7.4
DS-A 12-L/M 22 x 1.5	12	L PN 400 (1600)	27	22	29	14.0	27	14	M 22 x 1.5	10.3
DS-A 15-ML	15	L PN 400 (1600)	24	27	29	13.5	23	12	M 18 x 1.5	9.5
DS-A 15-L/M 16 x 1.5	15	L PN 400 (1600)	24	27	28	13.0	21	12	M 16 x 1.5	9.4
DS-A 15-L/M 22 x 1.5	15	L PN 400 (1600)	27	27	30	15.0	27	14	M 22 x 1.5	12.1
DS-A 18-ML	18	L PN 400 (1600)	27	32	31	14.5	27	14	M 22 x 1.5	13.7
DS-A 18-L/M 18 x 1.5	18	L PN 400 (1600)	27	32	30	14.0	23	12	M 18 x 1.5	13.2
DS-A 22-ML	22	L PN 250 (1000)	32	36	33	16.5	31	16	M 26 x 1.5	18.8
DS-A 22-L/M 22 x 1.5	22	L PN 250 (1000)	32	36	33	16.5	27	14	M 22 x 1.5	17.8
DS-A 28-ML	28	L PN 250 (1000)	41	41	34	17.5	39	18	M 33 x 2	25.8
DS-A 35-ML	35	L PB 250 (625)	50	50	39	17.5	49	20	M 42 x 2	42.0
DS-A 42-ML	42	L PB 250 (625)	55	60	42	19.0	55	22	M 48 x 2	57.5
DS-A 6-MS	6	S PB 630*	17	17	28	13.0	17	12	M 12 x 1.5	4.7
DS-A 8-MS	8	S PB 630*	19	19	30	15.0	19	12	M 14 x 1.5	6.5
DS-A 10-MS	10	S PB 630*	22	22	31	15.0	21	12	M 16 x 1.5	8.6
DS-A 12-MS	12	S PB 630*	24	24	33	17.0	23	12	M 18 x 1.5	10.9
DS-A 12-S/M 22 x 1.5	12	S PB 630*	27	24	34	17.5	27	14	M 22 x 1.5	13.0
DS-A 14-MS	14	S PB 630*	27	27	37	19.0	25	14	M 20 x 1.5	14.8
DS-A 16-MS	16	S PB 630*	27	30	37	18.5	27	14	M 22 x 1.5	16.6
DS-A 16-S/M 18 x 1.5	16	S PB 630*	27	30	36	18.0	23	12	M 18 x 1.5	15.7
DS-A 20-MS	20	S PB 400 (1000)	32	36	42	20.5	32	16	M 27 x 2	25.3
DS-A 25-MS	25	S PB 400 (1000)	41	46	47	23.0	39	18	M 33 x 2	46.5
DS-A 30-MS	30	S PB 250 (625)	50	50	50	23.5	49	20	M 42 x 2	64.4
DS-A 38-MS	38	S PB 250 (625)	55	60	57	26.0	55	22	M 48 x 2	87.3

L₁ = approximate length with nut tightened

Please see "Engineering and technical data - Selecting the correct tube fitting" for more information on pressure.

PIPE SCREW JOINTS A MALE STUD COUPLINGS

A MALE STUD COUPLING BSP WD

BSP parallel.

Captive seal NBR (e.g. Perbunan),
FPM (e.g. Viton) upon request.

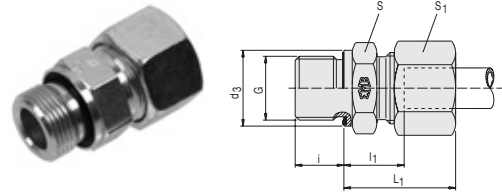

description	pipe OD	PN series	S	S ₁	L ₁	l ₁	d ₃	i	G	kg / 100 pcs
DS-A 6-RL/WD	6	L 500 (2200)	14	14	23	8.5	14	8	G 1/8" A	2.5
DS-A 6-L/R 1/4"/WD	6	L 500 (2200)	19	14	25	10.0	19	12	G 1/4" A	3.9
DS-A 8-RL/WD	8	L 500 (2200)	19	17	25	10.0	19	12	G 1/4" A	4.5
DS-A 8-L/R 1/8"/WD	8	L 500 (2200)	14	17	23	8.5	14	8	G 1/8" A	2.9
DS-A 8-L/R 3/8"/WD	8	L 500 (2200)	22	17	26	11.5	22	12	G 3/8" A	5.9
DS-A 10-RL/WD	10	L 500 (2200)	19	19	26	11.0	19	12	G 1/4" A	4.7
DS-A 10-L/R 3/8"/WD	10	L 500 (2200)	22	19	27	12.5	22	12	G 3/8" A	6.2
DS-A 10-L/R 1/2"/WD	10	L 500 (2200)	27	19	28	13.0	27	14	G 1/2" A	9.2
DS-A 12-RL/WD	12	L 400 (1700)	22	22	27	12.5	22	12	G 3/8" A	6.9
DS-A 12-L/R 1/4"/WD	12	L 400 (1700)	19	22	27	12.0	19	12	G 1/4" A	5.8
DS-A 12-L/R 1/2"/WD	12	L 400 (1700)	27	22	28	13.0	27	14	G 1/2" A	9.4
DS-A 15-RL/WD	15	L 400 (1700)	27	27	29	14.0	27	14	G 1/2" A	11.5
DS-A 15-L/R 3/8"/WD	15	L 400 (1700)	24	27	29	13.5	22	12	G 3/8" A	9.7
DS-A 18-RL/WD	18	L 400 (1700)	27	32	31	14.5	27	14	G 1/2" A	13.2
DS-A 18-L/R 3/4"/WD	18	L 400 (1700)	32	32	31	14.5	32	16	G 3/4" A	17.4
DS-A 22-RL/WD	22	L 250 (1100)	32	36	33	16.5	32	16	G 3/4" A	18.5
DS-A 28-RL/WD	28	L 250 (1100)	41	41	34	17.5	40	18	G 1" A	25.9
DS-A 35-RL/WD	35	L 250 (1100)	50	50	39	17.5	50	20	G 1 1/4" A	42.2
DS-A 42-RL/WD	42	L 250 (1100)	55	60	42	19.0	55	22	G 1 1/2" A	56.9
DS-A 6-RS/WD	6	S 800 (3400)	19	17	28	13.0	19	12	G 1/4" A	5.0
DS-A 8-RS/WD	8	S 800 (3400)	19	19	30	15.0	19	12	G 1/4" A	5.5
DS-A 8-S/R 3/8"/WD	8	S 800 (3400)	22	19	30	15.5	22	12	G 3/8" A	7.8
DS-A 10-RS/WD	10	S 800 (3400)	22	22	31	15.0	22	12	G 3/8" A	8.8
DS-A 10-S/R 1/4"/WD	10	S 800 (3400)	19	22	31	14.5	19	12	G 1/4" A	7.3
DS-A 10-S/R 1/2"/WD	10	S 800 (3400)	27	22	34	17.5	27	14	G 1/2" A	12.9
DS-A 12-RS/WD	12	S 630 (2700)	22	24	33	17.0	22	12	G 3/8" A	10.0
DS-A 12-S/R 1/4"/WD	12	S 630 (2700)	22	24	33	16.5	19	12	G 1/4" A	9.3
DS-A 12-S/R 1/2"/WD	12	S 630 (2700)	27	24	34	17.5	27	14	G 1/2" A	13.6
DS-A 14-RS/WD	14	S 630 (2700)	27	27	37	19.0	27	14	G 1/2" A	14.8
DS-A 16-RS/WD	16	S 630 (2700)	27	30	37	18.5	27	14	G 1/2" A	16.1
DS-A 16-S/R 3/8"/WD	16	S 630 (2700)	27	30	36	18.0	22	12	G 3/8" A	15.2
DS-A 16-S/R 3/4"/WD	16	S 630 (2700)	32	30	39	20.5	27	16	G 3/4" A	22.2
DS-A 20-RS/WD	20	S 400 (1700)	32	36	42	20.5	32	16	G 3/4" A	25.3
DS-A 25-RS/WD	25	S 400 (1700)	41	46	47	23.0	40	18	G 1" A	46.5
DS-A 25-S/R 1/2"/WD	25	S 400 (1700)	41	46	47	23.0	27	14	G 1/2" A	45.0
DS-A 30-RS/WD	30	S 400 (1700)	50	50	50	23.5	50	20	G 1 1/4" A	63.5
DS-A 38-RS/WD	38	S 400 (1700)	55	60	57	26.0	55	22	G 1 1/2" A	87.0

L₁ = approximate length with nut tightened

Please see "Engineering and technical data - Selecting the correct tube fitting" for more information on pressure.

PIPE SCREW JOINTS A MALE STUD COUPLINGS

THE WORLD OF TUBE FITTINGS

A MALE STUD COUPLING METRIC WD

Metric parallel.

Captive seal NBR (e.g. Perbunan),
FPM (e.g. Viton) upon request.

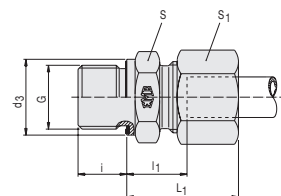

description	pipe OD	PN series	S	S ₁	L ₁	l ₁	d ₃	i	G	kg / 100 pcs
DS-A 6-ML/WD	6	L 500 (2200)	14	14	23	8.5	14	8	M 10 x 1	2.5
DS-A 8-ML/WD	8	L 500 (2200)	17	17	25	10.0	17	12	M 12 x 1.5	4.0
DS-A 10-ML/WD	10	L 500 (2200)	19	19	26	11.0	19	12	M 14 x 1.5	4.9
DS-A 12-ML/WD	12	L 400 (1700)	22	22	27	12.5	22	12	M 16 x 1.5	6.8
DS-A 12-L/M 18x1.5/WD	12	L 400 (1700)	24	22	27	12.5	24	12	M 18 x 1.5	7.4
DS-A 12-L/M 22x1.5/WD	12	L 400 (1700)	27	22	29	14.0	27	14	M 22 x 1.5	10.3
DS-A 15-ML/WD	15	L 400 (1700)	24	27	29	13.5	24	12	M 18 x 1.5	9.5
DS-A 15-L/M 22x1.5/WD	15	L 400 (1700)	27	27	30	15.0	27	14	M 22 x 1.5	12.0
DS-A 18-ML/WD	18	L 400 (1700)	27	32	31	14.5	27	14	M 22 x 1.5	13.7
DS-A 22-ML/WD	22	L 250 (1100)	32	36	33	16.5	32	16	M 26 x 1.5	18.8
DS-A 28-ML/WD	28	L 250 (1100)	41	41	34	17.5	40	18	M 33 x 2	25.8
DS-A 35-ML/WD	35	L 250 (1100)	50	50	39	17.5	50	20	M 42 x 2	42.0
DS-A 42-ML/WD	42	L 250 (1100)	55	60	42	19.0	55	22	M 48 x 2	57.5
DS-A 6-MS/WD	6	S 800 (3400)	17	17	28	13.0	17	12	M 12 x 1.5	4.7
DS-A 8-MS/WD	8	S 800 (3400)	19	19	30	15.0	19	12	M 14 x 1.5	6.5
DS-A 10-MS/WD	10	S 800 (3400)	22	22	31	15.0	22	12	M 16 x 1.5	8.6
DS-A 12-MS/WD	12	S 630 (2700)	24	24	33	17.0	24	12	M 18 x 1.5	10.9
DS-A 14-MS/WD	14	S 630 (2700)	27	27	37	19.0	26	14	M 20 x 1.5	14.8
DS-A 16-MS/WD	16	S 630 (2700)	27	30	37	18.5	27	14	M 22 x 1.5	16.6
DS-A 20-MS/WD	20	S 400 (1700)	32	36	42	20.5	32	16	M 27 x 2	25.3
DS-A 25-MS/WD	25	S 401 (1700)	41	46	47	23.0	40	18	M 33 x 2	46.5
DS-A 30-MS/WD	30	S 402 (1700)	50	50	50	23.5	50	20	M 42 x 2	64.4
DS-A 38-MS/WD	38	S 403 (1700)	55	60	57	26.0	55	22	M 48 x 2	87.3

L₁ = approximate length with nut tightened

Please see "Engineering and technical data - Selecting the correct tube fitting" for more information on pressure.

PIPE SCREW JOINTS A MALE STUD COUPLINGS

A MALE STUD COUPLING NPT

NPT (ANSI/ASME B1-20.1.1983).

Special dimensions.

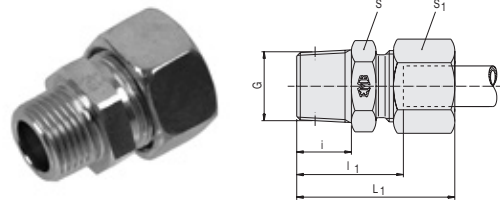

description	pipe OD	PN series	S	S ₁	L ₄	L ₄	i	G	kg / 100 pcs
A 4-LL/NPT	4	LL 100 (400)	11	10	28	18.0	10.0	1/8" NPT	1.5
A 6-LL/NPT	6	LL 100 (400)	11	12	28	16.5	10.0	1/8" NPT	1.5
A 8-LL/NPT	8	LL 100 (400)	12	14	30	18.5	10.0	1/8" NPT	2.0
DS-A 6-L / NPT	6	L 315 (1260)	12	14	32	18.0	10.0	1/8" NPT	2.6
DS-A 6-L 1/4" / NPT	6	L 315 (1260)	17	14	38	23.0	15.1	1/4" NPT	3.8
DS-A 8-L / NPT	8	L 315 (1260)	17	17	38	23.0	15.0	1/4" NPT	4.0
DS-A 10-L / NPT	10	L 315 (1260)	17	19	39	24.0	15.0	1/4" NPT	4.8
DS-A 10-L 3/8" / NPT	10	L 315 (1260)	19	19	40	25.0	15.2	3/8" NPT	6.0
DS-A 12-L / NPT	12	L 315 (1260)	19	22	40	25.0	15.0	3/8" NPT	6.5
DS-A 12-L 1/4" / NPT	12	L 315 (1260)	19	22	40	25.0	15.1	1/4" NPT	5.8
DS-A 12-L 1/2" / NPT	12	L 315 (1260)	24	22	45	30.0	19.8	1/2" NPT	8.9
DS-A 15-L / NPT	15	L 315 (1260)	24	27	46	31.0	20.0	1/2" NPT	11.0
DS-A 18-L / NPT	18	L 315 (1260)	27	32	48	31.5	20.0	1/2" NPT	13.5
DS-A 22-L / NPT	22	L 160 (640)	32	36	50	33.5	20.0	3/4" NPT	19.0
DS-A 28-L / NPT	28	L 160 (640)	41	41	56	39.5	25.0	1" NPT	27.5
DS-A 35-L / NPT	35	L 160 (640)	46	50	62	40.0	25.6	1 1/4" NPT	40.5
DS-A 42-L / NPT	42	L 160 (640)	55	60	65	42.0	26.0	1 1/2" NPT	57.0
DS-A 6-S / NPT	6	S 630 (2520)	17	17	43	26.0	15.0	1/4" NPT	5.0
DS-A 8-S / NPT	8	S 630 (2520)	17	19	43	28.0	15.0	1/4" NPT	5.5
DS-A 10-S / NPT	10	S 630 (2520)	19	22	44	27.5	15.0	3/8" NPT	8.0
DS-A 10-S 1/4" / NPT	10	S 630 (2520)	19	22	44	27.5	15.1	1/4" NPT	7.6
DS-A 12-S / NPT	12	S 630 (2520)	22	24	46	29.5	15.0	3/8" NPT	10.0
DS-A 12-S 1/4" / NPT	12	S 630 (2520)	22	24	46	29.5	15.1	1/4" NPT	9.4
DS-A 12-S 1/2" / NPT	12	S 630 (2520)	24	24	51	34.5	19.8	1/2" NPT	11.9
DS-A 14-S / NPT	14	S 630 (2520)	24	27	54	36.0	20.0	1/2" NPT	15.5
DS-A 16-S / NPT	16	S 630 (2520)	27	30	54	35.5	20.0	1/2" NPT	16.0
DS-A 20-S / NPT	20	S 400 (1600)	32	36	59	37.5	20.0	3/4" NPT	25.0
DS-A 25-S / NPT	25	S 400 (1600)	41	46	69	45.0	25.0	1" NPT	47.5
DS-A 30-S/NPT	30	S 400 (1600)	46	50	73	46.0	25.6	1 1/4" NPT	62.0
DS-A 38-S/NPT	38	S 400 (1600)	55	60	80	49.0	26.0	1 1/2" NPT	89.0

L₄ = approximate length with nut tightened

Please see "Engineering and technical data - Selecting the correct tube fitting" for more information on pressure.

PIPE SCREW JOINTS A MALE STUD COUPLINGS

THE WORLD OF TUBE FITTINGS

AP MALE STUD COUPLINGS BSP TAPER

BSP taper.

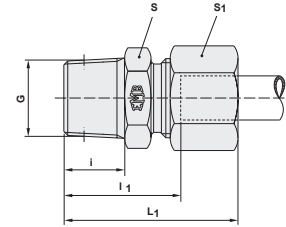

description	pipe OD	PN series	S	S ₁	L ₁	l ₁	i	G	kg / 100 pcs
DS-AP 6-L/R 1/8"	6	L 315 (1260)	12	14	30.0	15.0	8	R 1/8" K	2.2
DS-AP 8-L/R 1/4"	8	L 315 (1260)	17	17	35.0	20.0	12	R 1/4" K	3.8
DS-AP 10-L/R 1/4"	10	L 315 (1260)	17	19	37.0	22.0	12	R 1/4" K	4.3
DS-AP 12-L/R 3/8"	12	L 315 (1260)	19	22	37.0	22.0	12	R 3/8" K	6.0
DS-AP 15-L/R 1/2"	15	L 315 (1260)	24	27	40.0	25.0	14	R 1/2" K	10.3
DS-AP 18-L/R 1/2"	18	L 315 (1260)	27	32	42.0	25.5	14	R 1/2" K	12.7
DS-AP 22-L/R 3/4"	22	L 160 (640)	32	36	46.0	29.5	16	R 3/4" K	18.5
DS-AP 28-L/R 1"	28	L 161 (640)	41	41	51.5	34.5	18	R 1" K	25.8
DS-AP 35-L/R 1 1/4"	35	L 162 (640)	50	50	56.0	34.5	20	R 1 1/4" K	41.5
DS-AP 42-L/R 1 1/2"	42	L 163 (640)	55	60	61.0	38.0	22	R 1 1/2" K	56.7

L₁ = approximate length with nut tightened

Please see "Engineering and technical data - Selecting the correct tube fitting" for more information on pressure.

PIPE SCREW JOINTS A MALE STUD COUPLINGS

A MALE STUD COUPLING METRIC O-RING

Metric parallel (DIN ISO 6149-2 a. -3).

O-ring seal.

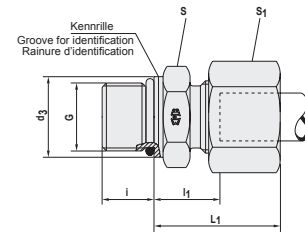

description	pipe OD	PN series	S	S ₁	L ₁	l ₁	d ₃	i	G	kg / 100 pcs	o-ring shore A-90
DS-A 6-ML/O	6	L 400 (1700)	14	14	24	9.5	14	9.5	M 10 x 1	2.4	8.1 x 1.6
DS-A 8-ML/O	8	L 400 (1700)	17	17	24	10.0	17	11.0	M 12 x 1.5	3.8	9.3 x 2.2
DS-A 10-ML/O	10	L 400 (1700)	19	19	25	11.0	19	11.0	M 14 x 1.5	5.1	11.3 x 2.2
DS-A 12-ML/O	12	L 400 (1700)	22	22	27	12.5	22	11.5	M 16 x 1.5	6.8	13.3 x 2.2
DS-A 15-ML/O	15	L 400 (1700)	24	27	28	13.5	24	14.0	M 18 x 1.5	9.5	15.3 x 2.2
DS-A 18-ML/O	18	L 400 (1700)	27	32	30	14.5	27	15.0	M 22 x 1.5	14.0	19.3 x 2.2
DS-A 22-ML/O	22	L 250 (1100)	32	36	32	16.5	32	18.5	M 27 x 2	18.8	23.6 x 2.9
DS-A 28-ML/O	28	L 250 (1100)	41	41	34	17.5	41	18.5	M 33 x 2	26.8	29.6 x 2.9
DS-A 35-ML/O	35	L 250 (1100)	50	50	39	17.5	50	19.0	M 42 x 2	43.4	38.6 x 2.9
DS-A 6-MS/O	6	S 630 (2700)	17	17	27	13.0	17	11.0	M 12 x 1.5	4.8	9.3 x 2.2
DS-A 8-MS/O	8	S 630 (2700)	19	19	29	15.0	19	11.0	M 14 x 1.5	6.4	11.3 x 2.2
DS-A 10-MS/O	10	S 630 (2700)	22	22	31	15.0	22	12.5	M 16 x 1.5	8.6	13.3 x 2.2
DS-A 12-MS/O	12	S 630 (2700)	24	24	33	17.0	24	14.0	M 18 x 1.5	10.9	15.3 x 2.2
DS-A 16-MS/O	16	S 630 (2700)	27	30	36	18.5	27	15.0	M 22 x 1.5	16.6	19.3 x 2.2
DS-A 20-MS/O	20	S 400 (1700)	32	36	42	20.5	32	18.5	M 27 x 2	26.2	23.6 x 2.9
DS-A 25-MS/O	25	S 400 (1700)	41	46	47	23.0	41	18.5	M 33 x 2	48.8	29.6 x 2.9
DS-A 30-MS/O	30	S 400 (1700)	50	50	50	23.5	50	19.0	M 42 x 2	66.2	38.6 x 2.9

L₁ = approximate length with nut tightened

O-rings NBR (e.g. Perbunan), FPM (e.g. Viton) upon request

Please see "Engineering and technical data - Selecting the correct tube fitting" for more information on pressure.

PIPE SCREW JOINTS A MALE STUD COUPLINGS

THE WORLD OF TUBE FITTINGS

A MALE STUD COUPLING UNF/UN O-RING

UNF/UN (ISO 11926-2 and 3).

O-ring-seal.

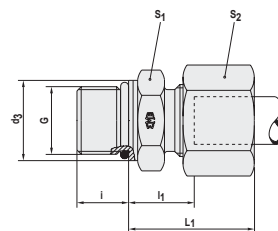

description	pipe OD	PN series	S	S ₁	L ₁	l ₁	d ₃	i	G	kg / 100 pcs	o-ring shore A-90
DS-A 8-L/7/16"-20 UNF	8	L 400 (1700)	17	17	25	10.0	14	9.0	7/16-20 UNF-2A	3.6	8.92 x 1.83
DS-A 10-S/9/16"-18 UNF	10	L 400 (1700)	17	19	26	11.0	14	9.0	7/16-20 UNF-2A	4.2	8.92 x 1.83
DS-A 12-L/7/16"-20 UNF	12	L 400 (1700)	19	22	26	11.0	17	10.0	9/16-18 UNF-2A	5.6	12.00 x 2.00
DS-A 12-L/3/4"-16 UNF	12	L 400 (1700)	24	22	28	13.0	22	11.0	3/4-16 UNF-2A	7.6	16.36 x 2.21
DS-A 12-L/7/8"-14 UNF	12	L 400 (1700)	27	22	29	14.3	27	12.7	7/8-14 UNF-2A	10.1	19.18 x 2.46
DS-A 15-L/3/4"-16 UNF	15	L 400 (1700)	24	27	29	14.0	22	11.0	3/4-16 UNF-2A	9.7	16.36 x 2.21
DS-A 15-L/7/8"-14 UNF	15	L 400 (1700)	27	27	30	15.3	27	12.7	7/8-14 UNF-2A	12.0	19.18 x 2.46
DS-A 18-L/3/4"-16 UNF	18	L 400 (1700)	27	32	31	14.5	22	11.0	3/4-16 UNF-2A	13.1	16.36 x 2.21
DS-A 18-L/7/8"-14 UNF	18	L 400 (1700)	27	32	31	14.8	27	12.7	7/8-14 UNF-2A	13.7	19.18 x 2.46
DS-A 22-L/7/8"-14 UNF	22	L 250 (1100)	32	36	33	16.8	27	12.7	7/8-14 UNF-2A	18.0	19.18 x 2.46
DS-A 22-L/1 1/16"-12 UN	22	L 250 (1100)	32	36	33	16.5	32	15.0	11/16-12 UN-2A	18.8	23.47 x 2.95
DS-A 22-L 1 5/16"-12 UN	22	L 250 (1100)	41	36	34	17.5	41	15.0	15/16-12 UN-2A	24.8	29.74 x 2.95
DS-A 28-L/1 1/16"-12 UN	28	L 250 (1100)	41	41	34	17.5	32	15.0	11/16-12 UN-2A	25.2	23.47 x 2.95
DS-A 28-L/1 5/16"-12 UN	28	L 250 (1100)	41	41	34	17.5	41	15.0	15/16-12 UN-2A	26.2	29.74 x 2.95
DS-A 35-L/1 5/16"-12 UN	35	L 250 (1100)	46	50	39	17.5	41	15.0	15/16-12 UN-2A	37.6	37.46 x 2.95
DS-A 35-L/1 5/8"-12 UN	35	L 250 (1100)	50	50	39	17.5	50	15.0	15/8-12 UN-2A	41.0	37.46 x 3
DS-A 42-L/1 5/8"-12 UN	42	L 250 (1100)	55	60	42	19.0	50	15.0	15/8-12 UN-2A	57.6	37.46 x 3
DS-A 8-S/7/16"-20 UNF	8	S 630 (2700)	17	19	30	15.0	14	9.0	7/16-20 UNF-2A	5.4	8.92 x 1.83
DS-A 10-S/9/16"-18 UNF	10	S 630 (2700)	19	22	31	14.5	17	10.0	9/16-18 UNF-2A	7.4	12.00 x 2.00
DS-A 12-S 9/16"-18 UNF	12	S 630 (2700)	22	24	31	14.5	17	10.0	9/16-18 UNF-2A	8.6	12.00 x 2.00
DS-A 12-S 3/4"-16 UNF	12	S 630 (2700)	24	24	34	17.5	22	11.0	3/4-16 UNF-2A	10.9	16.36 x 2.21
DS-A 16-S/3/4"-16 UNF	16	S 630 (2700)	24	30	34	15.5	22	11.0	3/4-16 UNF-2A	13.5	16.36 x 2.21
DS-A 16-S/7/8"-14 UNF	16	S 630 (2700)	27	30	37	18.8	27	12.7	7/8-14 UNF-2A	16.4	19.18 x 2.46
DS-A 20-S 3/4"-16 UNF	20	S 400 (1700)	32	36	42	20.5	22	11.0	3/4-16 UNF-2A	24.0	16.36 x 2.21
DS-A 20-S/7/8"-14 UNF	20	S 400 (1700)	32	36	42	20.8	27	12.7	7/8-14 UNF-2A	25.2	19.18 x 2.46
DS-A 20-S/1 1/16"-12 UN	20	S 400 (1700)	32	36	42	20.5	32	15.0	11/16-12 UN-2A	26.0	23.47 x 2.95
DS-A 25-S/1 1/16"-12 UN	25	S 400 (1700)	36	46	47	23.0	32	15.0	11/16-12 UN-2A	42.5	23.47 x 2.95
DS-A 25-S/1 5/16"-12 UN	25	S 400 (1700)	41	46	47	23.0	41	15.0	15/16-12 UN-2A	47.7	29.74 x 2.95
DS-A 30-S/1 5/16"-12 UN	30	S 400 (1700)	46	50	50	23.5	41	15.0	15/16-12 UN-2A	56.3	29.74 x 2.95
DS-A 30-S/1 5/8"-12 UN	30	S 400 (1700)	50	50	50	23.5	50	15.0	15/8-12 UN-2A	63.4	37.46 x 3
DS-A 38-S 1 5/8"-12 UN	38	S 400 (1700)	55	60	57	26.0	50	15.0	15/8-12 UN-2A	89.4	37.46 x 3

L₁ = approximate length with nut tightened

O-rings NBR (e.g. Perbunan). FPM (e.g. Viton) upon request

Please see "Engineering and technical data - Selecting the correct tube fitting" for more information on pressure.

PIPE SCREW JOINTS

B MALE STUD ELBOWS

B MALE STUD ELBOW BSP TAPER

BSP taper.

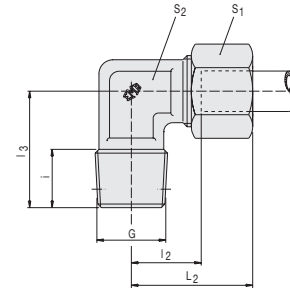

description	pipe OD	PN series	S ₁	S ₂	L ₂	l ₂	l ₃	i	G	kg / 100 pcs
B 4-RLL	4	LL 100 (400)	10	11	21	11.0	17	8	R 1/8" K	2.2
B 6-RLL	6	LL 100 (400)	12	11	21	9.5	17	8	R 1/8" K	2.5
B 8-RLL	8	LL 100 (400)	14	12	23	11.5	20	8	R 1/8" K	3.4
DS-B 6-RL	6	L 315 (1260)	14	12	27	12.0	20	8	R 1/8" K	4.0
DS-B 8-RL	8	L 315 (1260)	17	14	29	14.0	26	12	R 1/4" K	6.6
DS-B 10-RL	10	L 315 (1260)	19	17	30	15.0	27	12	R 1/4" K	8.3
DS-B 12-RL	12	L 315 (1260)	22	19	32	17.0	28	12	R 3/8" K	11.8
DS-B 15-RL	15	L 315 (1260)	27	19	36	21.0	34	14	R 1/2" K	13.0
DS-B 18-RL	18	L 315 (1260)	32	24	40	23.5	36	14	R 1/2" K	16.6
DS-B 6-RS	6	S 630* (2520)	17	14	31	16.0	26	12	R 1/4" K	7.2
DS-B 8-RS	8	S 630* (2520)	19	17	32	17.0	27	12	R 1/4" K	8.8
DS-B 10-RS	10	S 630* (2520)	22	19	34	17.5	28	12	R 3/8" K	13.4
DS-B 12-RS	12	S 630* (2520)	24	22	38	21.5	28	12	R 3/8" K	16.5
DS-B 14-RS	14	S 630* (2520)	27	19	40	22.0	32	14	R 1/2" K	15.3
DS-B 16-RS	16	S 630* (2520)	30	24	43	24.5	32	14	R 1/2" K	17.9

L₂ = approximate length with nut tightened

OD 4 to 12 mm manufactured from profile material

* PN 630 applies only to taper port forms; PN 400 is applicable to parallel port forms

Please see "Engineering and technical data - Selecting the correct tube fitting" for more information on pressure.

PIPE SCREW JOINTS

B MALE STUD ELBOWS

THE WORLD OF TUBE FITTINGS

B MALE STUD ELBOW METRIC TAPER

Metric taper.

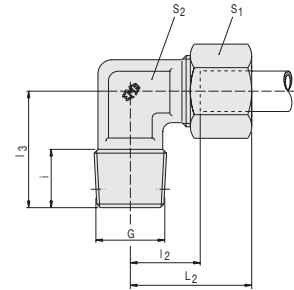

description	pipe OD	PN series	S ₁	S ₂	L ₂	L ₂	L ₃	i	G	kg / 100 pcs
B 4-MLL	4	LL 100 (400)	10	9	21	11.0	17	8	M 8x1 K	2.1
B 6-MLL	6	LL 100 (400)	12	11	21	9.5	17	8	M 10x1 K	2.5
B 8-MLL	8	LL 100 (400)	14	12	23	11.5	20	8	M 10x1 K	3.4
DS-B 6-ML	6	L 315 (1260)	14	12	27	12.0	20	8	M 10x1 K	4.0
DS-B 8-ML	8	L 315 (1260)	17	14	29	14.0	26	12	M 12x1.5 K	6.6
DS-B 10-ML	10	L 315 (1260)	19	17	30	15.0	27	12	M 14x1.5 K	8.3
DS-B 12-ML	12	L 315 (1260)	22	19	32	17.0	28	12	M 16x1.5 K	11.8
DS-B 15-ML	15	L 315 (1260)	27	19	36	21.0	32	12	M 18x1.5 K	12.0
DS-B 18-ML	18	L 315 (1260)	32	24	40	23.5	36	14	M 22x1.5 K	19.1
DS-B 6-MS	6	S 630* (2520)	17	14	31	16.0	26	12	M 12x1.5 K	7.5
DS-B 8-MS	8	S 630* (2520)	19	17	32	17.0	27	12	M 14x1.5 K	10.0
DS-B 10-MS	10	S 630* (2520)	22	19	34	17.5	28	12	M 16x1.5 K	13.8
DS-B 12-MS	12	S 630* (2520)	24	22	38	21.5	28	12	M 18x1.5 K	16.5
DS-B 14-MS	14	S 630* (2520)	27	19	40	22.0	32	14	M 20x1.5 K	15.3
DS-B 16-MS	16	S 630* (2520)	30	24	43	24.5	32	14	M 22x1.5 K	19.0

L₂ = approximate length with nut tightened

OD 4 to 12 mm manufactured from profile material

* PN 630 applies only to taper port forms; PN 400 is applicable to parallel port forms

Please see "Engineering and technical data - Selecting the correct tube fitting" for more information on pressure.

PIPE SCREW JOINTS B MALE STUD ELBOWS

B MALE STUD ELBOW NPT

NPT (ANSI/ASME B1-20.1.1983).

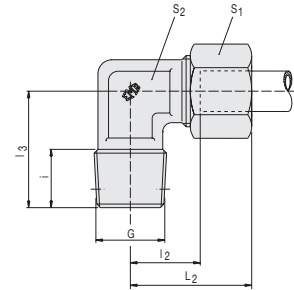

description	pipe OD	PN series	S ₁	S ₂	L ₂	l ₂	l ₃	i	G	kg / 100 pcs
B 4-LL/NPT	4	LL 100 (400)	10	11	21	11.0	17	10.0	1/8" NPT	2.1
B 6-LL/NPT	6	LL 100 (400)	12	11	21	9.5	17	10.0	1/8" NPT	2.4
B 8-LL/NPT	8	LL 100 (400)	14	12	23	11.5	20	10.0	1/8" NPT	3.3
DS-B 6-L/NPT	6	L 315 (1260)	14	12	27	12.0	20	10.0	1/8" NPT	4.0
DS-B 8-L/NPT	8	L 315 (1260)	17	14	29	14.0	26	15.0	1/4" NPT	6.3
DS-B 10-L/NPT	10	L 315 (1260)	19	17	30	15.0	27	15.0	1/4" NPT	8.2
DS-B 12-L/NPT	12	L 315 (1260)	22	19	32	17.0	28	15.0	3/8" NPT	11.6
DS-B 15-L/NPT	15	L 315 (1260)	27	19	36	21.0	34	20.0	1/2" NPT	14.0
DS-B 18-L/NPT	18	L 160 (640)	32	24	40	23.5	36	20.0	1/2" NPT	16.5
DS-B 22-L/NPT	22	L 160 (640)	36	27	44	27.5	42	20.0	3/4" NPT	23.5
DS-B 28-L/NPT	28	L 160 (640)	41	36	47	30.5	48	25.0	1" NPT	37.5
DS-B 35-L/NPT	35	L 160 (640)	50	41	56	34.5	54	25.5	1 1/4" NPT	57.5
DS-B 42-L/NPT	42	L 160 (640)	60	50	63	40.0	61	26.0	1 1/2" NPT	83.0
DS-B 6-S/NPT	6	S 630 (2520)	17	14	31	16.0	26	15.0	1/4" NPT	6.9
DS-B 8-S/NPT	8	S 630 (2520)	19	17	32	17.0	27	15.0	1/4" NPT	8.5
DS-B 10-S/NPT	10	S 630 (2520)	22	19	34	17.5	28	15.0	3/8" NPT	13.3
DS-B 12-S/NPT	12	S 630 (2520)	24	22	38	21.5	28	15.0	3/8" NPT	16.8
DS-B 14-S/NPT	14	S 630 (2520)	27	19	40	22.0	34	20.0	1/2" NPT	16.6
DS-B 16-S/NPT	16	S 630 (2520)	30	24	43	24.5	36	20.0	1/2" NPT	18.6
DS-B 20-S/NPT	20	S 400 (1600)	36	27	48	26.5	42	20.0	3/4" NPT	30.0
DS-B 25-S/NPT	25	S 400 (1600)	46	36	54	30.0	48	25.0	1" NPT	56.5
DS-B 30-S/NPT	30	S 400 (1600)	50	41	62	35.5	54	25.5	1 1/4" NPT	82.0
DS-B 38-S/NPT	38	S 400 (1600)	60	50	72	41.0	61	26.0	1 1/2" NPT	116.0

L₂ = approximate length with nut tightened

OD 4 to 12 mm manufactured from profile material

Please see "Engineering and technical data - Selecting the correct tube fitting" for more information on pressure.

PIPE SCREW JOINTS C MALE STUD BRANCH TEES

THE WORLD OF TUBE FITTINGS

C MALE STUD BRANCH TEE BSP TAPER

BSP taper.

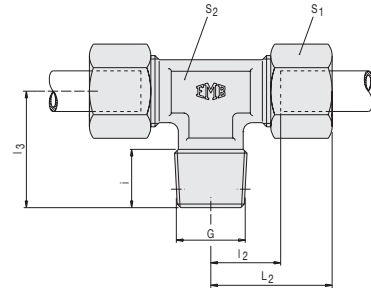

description	pipe OD	PN series	S ₁	S ₂ *	L ₂	l ₂	l ₃	i	G	kg / 100 pcs
C 4-RLL	4	LL 100 (400)		10/9	21	11.0	17	8	R 1/8" K	2.9
C 6-RLL	6	LL 100 (400)	12	11	21	9.5	17	8	R 1/8" K	3.4
C 8-RLL	8	LL 100 (400)	14	12/14	23	11.5	20	8	R 1/8" K	4.7
DS-C 6-RL	6	L 315 (1260)	14	12/14	27	12.0	20	8	R 1/8" K	6.0
DS-C 8-RL	8	L 315 (1260)	17	14	29	14.0	26	12	R 1/4" K	9.2
DS-C 10-RL	10	L 315 (1260)	19	17	30	15.0	27	12	R 1/4" K	11.7
DS-C 12-RL	12	L 315 (1260)	22	19	32	17.0	28	12	R 3/8" K	16.0
DS-C 15-RL	15	L 315 (1260)	27	19	36	21.0	34	14	R 1/2" K	20.3
DS-C 18-RL	18	L 315 (1260)	32	24	40	23.5	36	14	R 1/2" K	29.2
DS-C 6-RS	6	S 400 (1600)	17	14	31	16.0	26	12	R 1/4" K	10.9
DS-C 8-RS	8	S 400 (1600)	19	17	32	17.0	27	12	R 1/4" K	14.0
DS-C 10-RS	10	S 400 (1600)	22	19	34	17.5	28	12	R 3/8" K	19.0
DS-C 12-RS	12	S 400 (1600)	24	22	38	21.5	28	12	R 3/8" K	24.5
DS-C 14-RS	14	S 400 (1600)	27	19	40	22.0	32	14	R 1/2" K	24.4
DS-C 16-RS	16	S 400 (1600)	30	24	43	24.5	32	14	R 1/2" K	28.4

L₂ = approximate length with nut tightened

OD 4 to 12 mm manufactured from profile material

Please see "Engineering and technical data - Selecting the correct tube fitting" for more information on pressure.

* Depending on type of production, the wrench size may vary in some cases.

PIPE SCREW JOINTS

C MALE STUD BRANCH TEES

C MALE STUD BRANCH TEE METRIC TAPER

Metric taper.

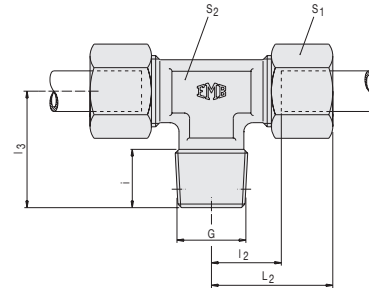

description	pipe OD	PN series	S ₁	S ₂ *	L ₂	l ₂	l ₃	i	G	kg / 100 pcs
C 4-MLL	4	LL 100 (400)		10/9	21	11.0	17	8	M 8x1 K	2.8
C 6-MLL	6	LL 100 (400)	12	11	21	9.5	17	8	M 10x1 K	3.4
C 8-MLL	8	LL 100 (400)	14	12/14	23	11.5	20	8	M 10x1 K	4.7
DS-C 6-ML	6	L 315 (1260)	14	12/14	27	12.0	20	8	M 10x1 K	6.0
DS-C 8-ML	8	L 315 (1260)	17	14	29	14.0	26	12	M 12x1.5 K	9.2
DS-C 10-ML	10	L 315 (1260)	19	17	30	15.0	27	12	M 14x1.5 K	11.7
DS-C 12-ML	12	L 315 (1260)	22	19	32	17.0	28	12	M 16x1.5 K	16.0
DS-C 15-ML	15	L 315 (1260)	27	19	36	21.0	32	12	M 18x1.5 K	19.3
DS-C 18-ML	18	L 315 (1260)	32	24	40	23.5	36	14	M 22x1.5 K	29.2
DS-C 6-MS	6	S 400 (1600)	17	14	31	16.0	26	12	M 12x1.5 K	10.9
DS-C 8-MS	8	S 400 (1600)	19	17	32	17.0	27	12	M 14x1.5 K	14.0
DS-C 10-MS	10	S 400 (1600)	22	19	34	17.5	28	12	M 16x1.5 K	19.0
DS-C 12-MS	12	S 400 (1600)	24	22	38	21.5	28	12	M 18x1.5 K	24.5
DS-C 14-MS	14	S 400 (1600)	27	19	40	22.0	32	14	M 20x1.5 K	24.4
DS-C 16-MS	16	S 400 (1600)	30	24	43	24.5	32	14	M 22x1.5 K	28.4

L₂ = approximate length with nut tightened

OD 4 to 12 mm manufactured from profile material

Please see "Engineering and technical data - Selecting the correct tube fitting" for more information on pressure.

* Depending on type of production, the wrench size may vary in some cases.

PIPE SCREW JOINTS C MALE STUD BRANCH TEES

THE WORLD OF TUBE FITTINGS

C MALE STUD BRANCH TEE NPT

NPT (ANSI/ASME B1-20.1.1983).

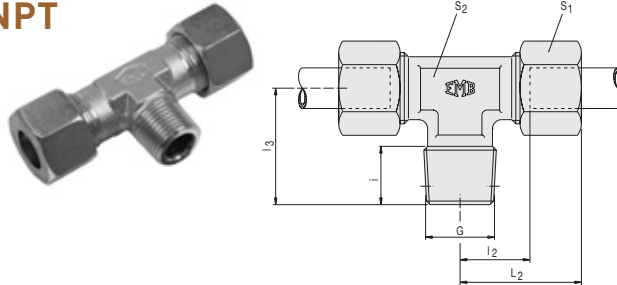

description	pipe OD	PN series	S ₁	S ₂	L ₂	l ₂	l ₃	i	G	kg / 100 pcs
C 4-LL/NPT	4	LL 100 (400)	10	11	21	11.0	17	10.0	1/8" NPT	2.2
C 6-LL/NPT	6	LL 100 (400)	12	11	21	9.5	17	10.0	1/8" NPT	2.8
C 8-LL/NPT	8	LL 100 (400)	14	12	23	11.5	20	10.0	1/8" NPT	3.7
DS-C 6-L/NPT	6	L 315 (1260)	14	12	27	12.0	20	10.0	1/8" NPT	4.5
DS-C 8-L/NPT	8	L 315 (1260)	17	14	29	14.0	26	15.0	1/4" NPT	6.5
DS-C 10-L/NPT	10	L 315 (1260)	19	17	30	15.0	27	15.0	1/4" NPT	8.5
DS-C 12-L/NPT	12	L 315 (1260)	22	19	32	17.0	28	15.0	3/8" NPT	12.0
DS-C 15-L/NPT	15	L 315 (1260)	27	19	36	21.0	34	20.0	1/2" NPT	21.0
DS-C 18-L/NPT	18	L 315 (1260)	32	24	40	23.5	36	20.0	1/2" NPT	28.0
DS-C 22-L/NPT	22	L 160 (640)	36	27	44	27.5	42	20.0	3/4" NPT	38.0
DS-C 28-L/NPT	28	L 161 (640)	41	36	47	30.5	48	25.0	1" NPT	56.0
DS-C 35-L/NPT	35	L 162 (640)	50	41	56	34.5	54	25.5	1 1/4" NPT	91.0
DS-C 42-L/NPT	42	L 163 (640)	60	50	63	40.0	61	26.0	1 1/2" NPT	137.0
DS-C 6-S/NPT	6	S 630 (2520)	17	14	31	16.0	26	15.0	1/4" NPT	8.5
DS-C 8-S/NPT	8	S 630 (2520)	19	17	32	17.0	27	15.0	1/4" NPT	10.5
DS-C 10-S/NPT	10	S 630 (2520)	22	19	34	17.5	28	15.0	3/8" NPT	15.0
DS-C 12-S/NPT	12	S 630 (2520)	24	22	38	21.5	28	15.0	3/8" NPT	18.0
DS-C 14-S/NPT	14	S 630 (2520)	27	19	40	22.0	34	20.0	1/2" NPT	25.0
DS-C 16-S/NPT	16	S 630 (2520)	30	24	43	24.5	36	20.0	1/2" NPT	34.5
DS-C 20-S/NPT	20	S 400 (1600)	36	27	48	26.5	42	20.0	3/4" NPT	49.5
DS-C 25-S/NPT	25	S 400 (1600)	46	36	54	30.0	48	25.0	1" NPT	92.5
DS-C 30-S/NPT	30	S 400 (1600)	50	41	62	35.5	54	25.5	1 1/4" NPT	128.0
DS-C 38-S/NPT	38	S 400 (1600)	60	50	72	41.0	61	26.0	1 1/2" NPT	189.0

L₂ = approximate length with nut tightened

OD 4 to 12 mm manufactured from profile material

Please see "Engineering and technical data - Selecting the correct tube fitting" for more information on pressure.

PIPE SCREW JOINTS

D MALE STUD RUN TEES

D MALE STUD RUN TEE BSP TAPER

BSP taper.

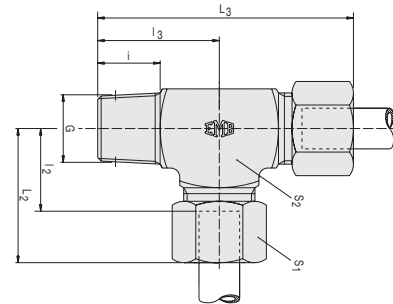

description	pipe OD	PN series	S ₁	S ₂ *	L ₂	l ₂	L ₃	l ₃	i	G	kg / 100 pcs
D 4-RLL	4	LL 100 (400)	10	11	21	11.0	38	17	8	R 1/8" K	2.9
D 6-RLL	6	LL 100 (400)	12	11	21	9.5	38	17	8	R 1/8" K	3.5
D 8-RLL	8	LL 100 (400)	14	12	23	11.5	43	20	8	R 1/8" K	4.7
DS-D 6-RL	6	L 315 (1260)	14	12/14	27	12.0	47	20	8	R 1/8" K	6.0
DS-D 8-RL	8	L 315 (1260)	17	14	29	14.0	55	26	12	R 1/4" K	9.1
DS-D 10-RL	10	L 315 (1260)	19	17	30	15.0	57	27	12	R 1/4" K	11.4
DS-D 12-RL	12	L 315 (1260)	22	19	32	17.0	60	28	12	R 3/8" K	16.2
DS-D 15-RL	15	L 315 (1260)	27	19	36	21.0	70	34	14	R 1/2" K	20.0
DS-D 18-RL	18	L 315 (1260)	32	24	40	23.5	76	36	14	R 1/2" K	26.7
DS-D 6-RS	6	S 400 (1600)	17	14	31	16.0	57	26	12	R 1/4" K	10.8
DS-D 8-RS	8	S 400 (1600)	19	17	32	17.0	59	27	12	R 1/4" K	13.8
DS-D 10-RS	10	S 400 (1600)	22	19	34	17.5	62	28	12	R 3/8" K	19.0
DS-D 12-RS	12	S 400 (1600)	24	22	38	21.5	66	28	12	R 3/8" K	24.3
DS-D 14-RS	14	S 400 (1600)	27	19	40	22.0	72	32	14	R 1/2" K	23.4
DS-D 16-RS	16	S 400 (1600)	30	24	43	24.5	75	32	14	R 1/2" K	30.7

L_2+L_3 = approximate length with nut tightened

OD 4 to 12 mm manufactured from profile material

Please see "Engineering and technical data - Selecting the correct tube fitting" for more information on pressure.

* Depending on type of production, the wrench size may vary in some cases

PIPE SCREW JOINTS D MALE STUD RUN TEES

THE WORLD OF TUBE FITTINGS

D MALE STUD RUN TEE METRIC TAPER

Metric taper.

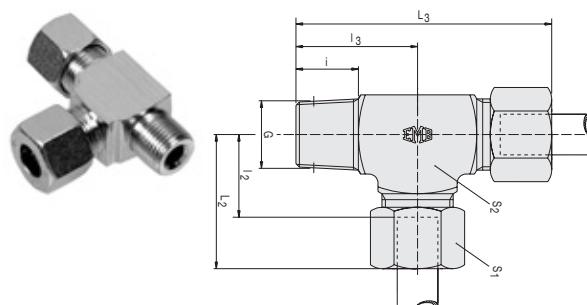

description	pipe OD	PN series	S ₁	S ₂ *	L ₂	l ₂	L ₃	l ₃	i	G	kg / 100 pcs
D 4-MLL	4	LL 100 (400)	10	9	21	11.0	38	17	8	M 8x1 K	2.8
D 6-MLL	6	LL 100 (400)	12	11	21	9.5	38	17	8	M 10x1 K	3.5
D 8-MLL	8	LL 100 (400)	14	12	23	11.5	43	20	8	M 10x1 K	4.7
DS-D 6-ML	6	L 315 (1260)	14	12/14	27	12.0	47	20	8	M 10x1 K	6.0
DS-D 8-ML	8	L 315 (1260)	17	14	29	14.0	55	26	12	M 12x1.5 K	9.1
DS-D 10-ML	10	L 315 (1260)	19	17	30	15.0	57	27	12	M 14x1.5 K	11.4
DS-D 12-ML	12	L 315 (1260)	22	19	32	17.0	60	28	12	M 16x1.5 K	16.2
DS-D 15-ML	15	L 315 (1260)	27	19	36	21.0	68	32	12	M 18x1.5 K	18.6
DS-D 18-ML	18	L 315 (1260)	32	24	40	23.5	76	36	14	M 22x1.5 K	26.6
DS-D 6-MS	6	S 400 (1600)	17	14	31	16.0	57	26	12	M 12x1.5 K	10.8
DS-D 8-MS	8	S 400 (1600)	19	17	32	17.0	59	27	12	M 14x1.5 K	13.8
DS-D 10-MS	10	S 400 (1600)	22	19	34	17.5	62	28	12	M 16x1.5 K	19.0
DS-D 12-MS	12	S 400 (1600)	24	22	38	21.5	66	28	12	M 18x1.5 K	24.3
DS-D 14-MS	14	S 400 (1600)	27	19	40	22.0	72	32	14	M 20x1.5 K	23.8
DS-D 16-MS	16	S 400 (1600)	30	24	43	24.5	75	32	14	M 22x1.5 K	31.9

L_2+L_3 = approximate length with nut tightened

OD 4 to 12 mm manufactured from profile material

Please see "Engineering and technical data - Selecting the correct tube fitting" for more information on pressure.

* Depending on type of production, the wrench size may vary in some cases

PIPE SCREW JOINTS D MALE STUD RUN TEES

D MALE STUD RUN TEE NPT

NPT (ANSI/ASME B1-20.1.1983).

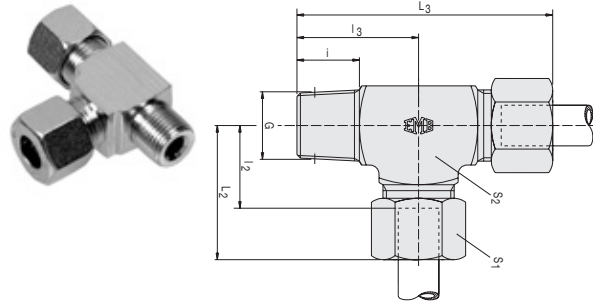

description	pipe OD	PN series	S ₁	S ₂	L ₂	l ₂	L ₃	l ₃	i	G	kg / 100 pcs
D 4-LL/NPT	4	LL 100 (400)	10	11	21	11.0	36	15	10.0	1/8" NPT	2.3
D 6-LL/NPT	6	LL 100 (400)	12	9	21	9.5	36	15	10.0	1/8" NPT	2.9
D 8-LL/NPT	8	LL 100 (400)	14	12	23	11.5	42	19	10.0	1/8" NPT	3.7
DS-D 6-L/NPT	6	L 315 (1260)	14	12	27	12.0	46	19	10.0	1/8" NPT	5.0
DS-D 8-L/NPT	8	L 315 (1260)	17	14	29	14.0	52	23	15.0	1/4" NPT	6.5
DS-D 10-L/NPT	10	L 315 (1260)	19	17	30	15.0	54	24	15.0	1/4" NPT	8.5
DS-D 12-L/NPT	12	L 315 (1260)	22	19	32	17.0	57	25	15.0	3/8" NPT	12.5
DS-D 15-L/NPT	15	L 315 (1260)	27	19	36	21.0	66	30	20.0	1/2" NPT	20.5
DS-D 18-L/NPT	18	L 315 (1260)	32	24	40	23.5	73	33	20.0	1/2" NPT	26.5
DS-D 22-L/NPT	22	L 160 (640)	36	27	44	27.5	86	42	20.0	3/4" NPT	36.5
DS-D 28-L/NPT	28	L 160 (640)	41	36	47	30.5	95	48	25.0	1" NPT	56.0
DS-D 35-L/NPT	35	L 160 (640)	50	41	56	34.5	110	54	25.5	1 1/4" NPT	81.0
DS-D 42-L/NPT	42	L 160 (640)	60	50	63	40.0	124	61	26.0	1 1/2" NPT	115.0
DS-D 6-S/NPT	6	S 630 (2520)	17	14	31	16.0	54	23	15.0	1/4" NPT	9.0
DS-D 8-S/NPT	8	S 630 (2520)	19	17	32	17.0	56	24	15.0	1/4" NPT	10.5
DS-D 10-S/NPT	10	S 630 (2520)	22	19	34	17.5	59	25	15.0	3/8" NPT	15.6
DS-D 12-S/NPT	12	S 630 (2520)	24	22	38	21.5	66	28	15.0	3/8" NPT	18.0
DS-D 14-S/NPT	14	S 630 (2520)	27	19	40	22.0	70	30	20.0	1/2" NPT	24.5
DS-D 16-S/NPT	16	S 630 (2520)	30	24	43	24.5	76	33	20.0	1/2" NPT	32.0
DS-D 20-S/NPT	20	S 400 (1600)	36	27	48	26.5	90	42	20.0	3/4" NPT	49.0
DS-D 25-S/NPT	25	S 400 (1600)	46	36	54	30.0	102	48	25.0	1" NPT	82.2
DS-D 30-S/NPT	30	S 400 (1600)	50	41	62	35.5	116	54	25.5	1 1/4" NPT	109.5
DS-D 38-S/NPT	38	S 400 (1600)	60	50	72	41.0	133	61	26.0	1 1/2" NPT	155.0

L_2+L_3 = approximate length with nut tightened

OD 4 to 12 mm manufactured from profile material

Please see "Engineering and technical data - Selecting the correct tube fitting" for more information on pressure.

PIPE SCREW JOINTS E STRAIGHT COUPLINGS

THE WORLD OF TUBE FITTINGS

E STRAIGHT COUPLINGS

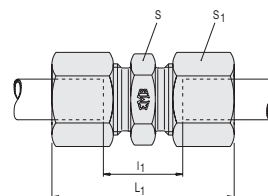

description	pipe OD	PN series	S	S ₁	L ₁	L ₁	kg / 100 pcs
E 4-LL	4	LL 100 (400)	9	10	31	12	1.4
E 6-LL	6	LL 100 (400)	11	12	32	9	2.1
E 8-LL	8	LL 100 (400)	12	14	35	12	2.6
DS-E 6-L	6	L 500 (2200)	12	14	39	10	3.5
DS-E 8-L	8	L 500 (2200)	14	17	40	11	4.9
DS-E 10-L	10	L 500 (2200)	17	19	42	13	6.9
DS-E 12-L	12	400 (1700)	19	22	43	14	8.5
DS-E 15-L	15	400 (1700)	24	27	46	16	13.8
DS-E 18-L	18	400 (1700)	27	32	48	16	19.5
DS-E 22-L	22	250 (1100)	32	36	52	20	26.2
DS-E 28-L	28	250 (1100)	41	41	54	21	31.5
DS-E 35-L	35	250 (1100)	46	50	63	20	49.4
DS-E 42-L	42	250 (1100)	55	60	66	21	72.8
DS-E 6-S	6	S 800 (3400)	14	17	45	16	5.9
DS-E 8-S	8	S 800 (3400)	17	19	47	18	7.8
DS-E 10-S	10	S 800 (3400)	19	22	49	17	11.0
DS-E 12-S	12	630 (2700)	22	24	51	19	13.6
DS-E 14-S	14	630 (2700)	24	27	57	22	18.2
DS-E 16-S	16	630 (2700)	27	30	57	21	22.3
DS-E 20-S	20	400 (1700)	32	36	66	23	34.7
DS-E 25-S	25	400 (1700)	41	46	74	26	66.9
DS-E 30-S	30	400 (1700)	46	50	80	27	80.9
DS-E 38-S	38	400 (1700)	55	60	90	29	119.4

L₁ = approximate length with nut tightened

Please see "Engineering and technical data - Selecting the correct tube fitting" for more information on pressure.

PIPE SCREW JOINTS ER STRAIGHT REDUCING COUPLINGS

ER STRAIGHT REDUCING COUPLINGS

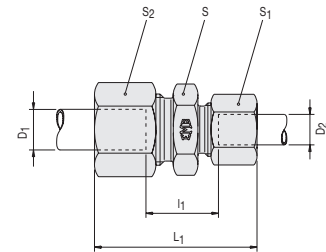

description	pipe OD ₁	Pipe OD ₂	PN series	S	S ₁	S ₂	L ₁	l ₁	kg / 100 pcs
ER 6/4-LL	6	4	LL 100 (400)	11	10	12	32	10.5	1.8
ER 8/4-LL	8	4	LL 100 (400)	12	10	14	34	12.5	2.1
ER 8/6-LL	8	6	LL 100 (400)	12	12	14	34	11.0	2.3
DS-ER 8/6-L	8	6	L 500 (2200)	14	14	17	40	11.0	4.3
DS-ER 10/6-L	10	6	L 500 (2200)	17	14	19	41	12.0	5.2
DS-ER 10/8-L	10	8	L 500 (2200)	17	17	19	41	12.0	5.7
DS-ER 12/6-L	12	6	L 400 (1700)	19	14	22	42	13.0	6.5
DS-ER 12/8-L	12	8	L 400 (1700)	19	17	22	42	13.0	7.0
DS-ER 12/10-L	12	10	L 400 (1700)	19	19	22	43	14.0	7.5
DS-ER 15/10-L	15	10	L 400 (1700)	24	19	27	45	15.0	10.7
DS-ER 15/12-L	15	12	L 400 (1700)	24	22	27	45	15.0	11.4
DS-ER 18/10-L	18	10	L 400 (1700)	27	19	32	46	15.5	14.3
DS-ER 18/12-L	18	12	L 400 (1700)	27	22	32	46	15.5	15.0
DS-ER 18/15-L	18	15	L 400 (1700)	27	27	32	48	16.5	17.2
DS-ER 22/12-L	22	12	L 250 (1100)	32	22	36	48	17.5	19.3
DS-ER 22/15-L	22	15	L 250 (1100)	32	27	36	50	18.5	21.8
DS-ER 22/18-L	22	18	L 250 (1100)	32	32	36	50	18.0	23.8
DS-ER 28/18-L	28	18	L 250 (1100)	41	32	41	52	19.0	30.6
DS-ER 28/22-L	28	22	L 250 (1100)	41	36	41	54	21.0	32.6
DS-ER 35/22-L	35	22	L 250 (1100)	46	36	50	59	21.0	44.3
DS-ER 35/28-L	35	28	L 250 (1100)	46	41	50	59	21.0	46.1
DS-ER 8/6-S	8	6	S 800 (3400)	17	17	19	47	18.0	7.4
DS-ER 10/6-S	10	6	S 800 (3400)	19	17	22	48	17.5	9.1
DS-ER 10/8-S	10	8	S 800 (3400)	19	19	22	48	17.5	9.5
DS-ER 12/6-S	12	6	S 630 (2700)	22	17	24	50	19.5	11.1
DS-ER 12/8-S	12	8	S 630 (2700)	22	19	24	50	19.5	11.5
DS-ER 12/10-S	12	10	S 630 (2700)	22	22	24	51	19.0	12.7
DS-ER 14/10-S	14	10	S 630 (2700)	24	22	27	54	20.5	15.6
DS-ER 14/12-S	14	12	S 630 (2700)	24	24	27	54	20.5	16.2
DS-ER 16/12-S	16	12	S 630 (2700)	27	24	30	54	20.0	18.8
DS-ER 16/14-S	16	14	S 630 (2700)	27	27	30	57	21.5	21.2
DS-ER 20/10-S	20	10	S 400 (1700)	32	22	36	60	22.0	27.1
DS-ER 20/12-S	20	12	S 400 (1700)	32	24	36	60	22.0	27.7
DS-ER 20/16-S	20	16	S 400 (1700)	32	30	36	63	23.0	31.3
DS-ER 25/16-S	25	16	S 400 (1700)	41	30	46	68	25.5	51.2
DS-ER 25/20-S	25	20	S 400 (1700)	41	36	46	71	25.5	56.4
DS-ER 30/20-S	30	20	S 400 (1700)	46	36	50	74	26.0	65.1
DS-ER 30/25-S	30	25	S 400 (1700)	46	46	50	77	26.5	77.8
DS-ER 38/30-S	38	30	S 400 (1700)	55	50	60	87	29.5	110.3

L₁ = approximate length with nut tightened

Please see "Engineering and technical data - Selecting the correct tube fitting" for more information on pressure.

PIPE SCREW JOINTS F EQUAL ELBOWS

THE WORLD OF TUBE FITTINGS

F EQUAL ELBOWS

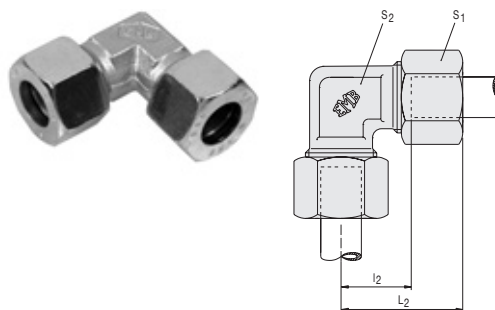

description	pipe OD	PN series	S ₁	S ₂ *	L ₂	l ₂	kg / 100 pcs
F 4-LL	4	LL 100 (400)	10	9	21	11.0	2.5
F 6-LL	6	LL 100 (400)	12	11	21	9.5	2.8
F 8-LL	8	LL 100 (400)	14	12	23	11.5	3.8
DS-F 6-L	6	L 500 (2200)	14	12	27	12.0	4.9
DS-F 8-L	8	L 500 (2200)	17	14	29	14.0	7.6
DS-F 10 L	10	L 500 (2200)	19	14/ 17	30	15.0	9.6
DS-F 12-L	12	L 400 (1700)	22	17	32	17.0	13.5
DS-F 15-L	15	L 400 (1700)	27	19	36	21.0	15.8
DS-F 18-L	18	L 400 (1700)	32	24	40	23.5	23.9
DS-F 22-L	22	L 250 (1100)	36	27	44	27.5	31.7
DS-F 28-L	28	L 250 (1100)	41	36	47	30.5	42.0
DS-F 35-L	35	L 250 (1100)	50	41	56	34.5	75.9
DS-F 42-L	42	L 250 (1100)	60	50	63	40.0	107.8
DS-F 6-S	6	S 800 (3400)	17	14	31	16.0	8.5
DS-F 8-S	8	S 800 (3400)	19	14/ 17	32	17.0	11.7
DS-F 10-S	10	S 800 (3400)	22	17	34	17.5	16.1
DS-F 12-S	12	S 630 (2700)	24	22	38	21.5	20.5
DS-F 14-S	14	S 630 (2700)	27	19	40	22.0	20.7
DS-F 16-S	16	S 630 (2700)	30	24	43	24.5	25.0
DS-F 20-S	20	S 400 (1700)	36	27	48	26.5	40.7
DS-F 25-S	25	S 400 (1700)	46	36	54	30.0	77.6
DS-F 30-S	30	S 400 (1700)	50	41	62	35.5	97.4
DS-F 38-S	38	S 400 (1700)	60	50	72	41.0	131.8

L₂ = approximate length with nut tightened

OD 4 to 12 mm manufactured from profile material

Please see "Engineering and technical data - Selecting the correct tube fitting" for more information on pressure.

** Depending on type of production, the wrench size may vary in some cases*

PIPE SCREW JOINTS

G EQUAL TEES

G EQUAL TEES

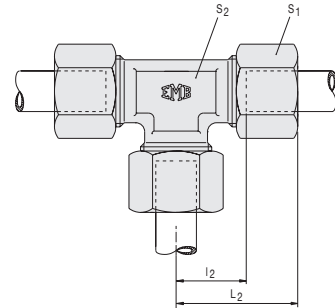

description	pipe OD	PN series	S ₁	S ₂ *	L ₂	l ₂	kg / 100 pcs
G 4-LL	4	LL 100 (400)	10	9	21	11.0	2.9
G 6-LL	6	LL 100 (400)	12	12	21	9.5	3.8
G 8-LL	8	LL 100 (400)	14	12/14	23	11.5	5.1
DS-G 6-L	6	L 500 (2200)	14	12	27	12.0	7.1
DS-G 8-L	8	L 500 (2200)	17	14	29	14.0	10.1
DS-G 10-L	10	L 500 (2200)	19	17	30	15.0	13.0
DS-G 12-L	12	L 400 (1700)	22	19	32	17.0	17.7
DS-G 15-L	15	L 400 (1700)	27	19	36	21.0	23.2
DS-G 18-L	18	L 400 (1700)	32	24	40	23.5	35.4
DS-G 22-L	22	L 250 (1100)	36	27	44	27.5	44.3
DS-G 28-L	28	L 250 (1100)	41	36	47	30.5	61.1
DS-G 35-L	35	L 250 (1100)	50	41	56	34.5	90.1
DS-G 42-L	42	L 250 (1100)	60	50	63	40.0	136.8
DS-G 6-S	6	S 800 (3400)	17	14	31	16.0	12.0
DS-G 8-S	8	S 800 (3400)	19	17	32	17.0	15.7
DS-G 10-S	10	S 800 (3400)	22	19	34	17.5	21.2
DS-G 12-S	12	S 630 (2700)	24	22/17	38	21.5	28.5
DS-G 14-S	14	S 630 (2700)	27	19	40	22.0	28.5
DS-G 16-S	16	S 630 (2700)	30	24	43	24.5	35.9
DS-G 20-S	20	S 400 (1700)	36	27	48	26.5	55.8
DS-G 25-S	25	S 400 (1700)	46	36	54	30.0	106.7
DS-G 30-S	30	S 400 (1700)	50	41	62	35.5	134.9
DS-G 38-S	38	S 400 (1700)	60	50	72	41.0	202.2

L₂ = approximate length with nut tightened

OD 4 to 12 mm manufactured from profile material

Please see "Engineering and technical data - Selecting the correct tube fitting" for more information on pressure.

* Depending on type of production, the wrench size may vary in some cases

PIPE SCREW JOINTS GR TEE REDUCERS

THE WORLD OF TUBE FITTINGS

GR TEE REDUCERS

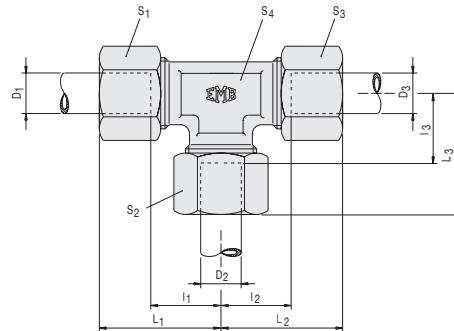

description	pipe OD ₁	Pipe OD ₂	Pipe OD ₃	PN series	S ₁	S ₂	S ₃	S ₄	L ₁	L ₂	L ₃	l ₁	l ₂	l ₃	kg / 100 pcs
GR 4/8/4-LL	4	8	4	LL 100 (400)	10	14	10	12	23	23	23	13.0	13.0	11.5	4.3
GR 6/4/6-LL	6	4	6	LL 100 (400)	12	10	12	11	21	21	21	9.5	9.5	11.0	3.5
DS-GR 6/8/6-L	6	8	6	L 500 (2200)	14	17	14	14	29	29	29	14.0	14.0	14.0	9.2
DS-GR 8/6/8-L	8	6	8	L 500 (2200)	17	14	17	14	29	29	29	14.0	14.0	14.0	9.5
DS-GR 6/10/6-L	6	10	6	L 500 (2200)	14	19	14	14	30	30	30	15.0	15.0	15.0	11.4
DS-GR 8/10/8-L	8	10	8	L 500 (2200)	17	19	17	14	30	30	30	15.0	15.0	15.0	12.2
DS-GR 10/6/10-L	10	6	10	L 500 (2200)	19	14	19	14	30	30	30	15.0	15.0	15.0	12.1
DS-GR 10/8/10-L	10	8	10	L 500 (2200)	19	17	19	14	30	30	30	15.0	15.0	15.0	12.2
DS-GR 10/10/6-L	10	10	6	L 500 (2200)	19	19	14	14	30	30	30	15.0	15.0	15.0	12.1
DS-GR 8/12/8-L	8	12	8	L 400 (1700)	17	22	17	17	32	32	32	17.0	17.0	17.0	16.0
DS-GR 12/6/12-L	12	6	12	L 400 (1700)	22	14	22	17	32	32	32	17.0	17.0	17.0	15.9
DS-GR 12/8/8-L	12	8	8	L 400 (1700)	22	17	17	17	32	32	32	17.0	17.0	17.0	16.0
DS-GR 12/8/12-L	12	8	12	L 400 (1700)	22	17	22	17	32	32	32	17.0	17.0	17.0	16.4
DS-GR 12/10/10-L	12	10	10	L 400 (1700)	22	19	19	17	32	32	32	17.0	17.0	17.0	16.2
DS-GR 12/10/12-L	12	10	12	L 400 (1700)	22	19	22	17	32	32	32	17.0	17.0	17.0	16.7
DS-GR 12/12/10-L	12	12	10	L 400 (1700)	22	22	19	17	32	32	32	17.0	17.0	17.0	16.7
DS-GR 10/15/10-L	10	15	10	L 400 (1700)	19	27	19	19	36	36	36	21.0	21.0	21.0	18.8
DS-GR 12/15/12-L	12	15	12	L 400 (1700)	22	27	22	19	36	36	36	21.0	21.0	21.0	19.2
DS-GR 15/6/15-L	15	6	15	L 400 (1700)	27	14	27	19	36	36	36	21.0	21.0	21.0	19.4
DS-GR 15/10/15-L	15	10	15	L 400 (1700)	27	19	27	19	36	36	36	21.0	21.0	21.0	20.7
DS-GR 15/12/12-L	15	12	12	L 400 (1700)	27	22	22	19	36	36	36	21.0	21.0	21.0	18.8
DS-GR 15/12/15-L	15	12	15	L 400 (1700)	27	22	27	19	36	36	36	21.0	21.0	21.0	21.1
DS-GR 15/15/12-L	15	15	12	L 400 (1700)	27	27	22	19	36	36	36	21.0	21.0	21.0	20.8
DS-GR 12/18/12-L	12	18	12	L 400 (1700)	22	32	22	24	39	39	40	24.0	24.0	23.5	26.3
DS-GR 18/10/10-L	18	10	10	L 400 (1700)	32	19	19	24	40	39	39	23.5	24.0	24.0	25.9
DS-GR 18/10/18-L	18	10	18	L 400 (1700)	32	19	32	24	40	40	39	23.5	23.5	24.0	29.7
DS-GR 18/12/18-L	18	12	18	L 400 (1700)	32	22	32	24	40	40	39	23.5	23.5	24.0	29.7
DS-GR 18/15/18-L	18	15	18	L 400 (1700)	32	27	32	24	40	40	39	23.5	23.5	24.0	31.6
DS-GR 18/18/10-L	18	18	10	L 400 (1700)	32	32	19	24	40	39	40	23.5	24.0	23.5	29.6
DS-GR 22/10/22-L	22	10	22	L 250 (1100)	36	19	36	27	44	44	43	27.5	27.5	28.0	39.1
DS-GR 22/12/22-L	22	12	22	L 250 (1100)	36	22	36	27	44	44	43	27.5	27.5	28.0	39.7
DS-GR 22/15/15-L	22	15	15	L 250 (1100)	36	27	27	27	44	43	43	27.5	28.0	28.0	37.7
DS-GR 22/15/22-L	22	15	22	L 250 (1100)	36	27	36	27	44	44	43	27.5	27.5	28.0	41.0
DS-GR 22/18/18-L	22	18	18	L 250 (1100)	36	32	32	27	44	44	44	27.5	27.5	27.5	42.2
DS-GR 22/18/22-L	22	18	22	L 250 (1100)	36	32	36	27	44	44	44	27.5	27.5	27.5	43.5
DS-GR 22/22/18-L	22	22	18	L 250 (1100)	36	36	32	27	44	44	44	27.5	27.5	27.5	43.1
DS-GR 28/10/28-L	28	10	28	L 250 (1100)	41	19	41	36	47	47	46	30.5	30.5	31.0	55.7
DS-GR 28/12/28-L	28	12	28	L 250 (1100)	41	22	41	36	47	47	46	30.5	30.5	31.0	56.3
DS-GR 28/15/28-L	28	15	28	L 250 (1100)	41	27	41	36	47	47	46	30.5	30.5	31.0	59.7

PIPE SCREW JOINTS GR TEE REDUCERS

description	pipe OD ₁	Pipe OD ₂	Pipe OD ₃	PN series	S ₁	S ₂	S ₃	S ₄	L ₁	L ₂	L ₃	l ₁	l ₂	l ₃	kg / 100 pcs
DS-GR 28/18/28-L	28	18	28	L 250 (1100)	41	32	41	36	47	47	47	30.5	30.5	30.5	59.7
DS-GR 28/22/22-L	28	22	22	L 250 (1100)	41	36	36	36	47	47	47	30.5	30.5	30.5	60.2
DS-GR 28/22/28-L	28	22	28	L 250 (1100)	41	36	41	36	47	47	47	30.5	30.5	30.5	60.3
DS-GR 10/6/10-S	10	6	10	S 800 (3400)	22	17	22	17	34	34	33	17.5	17.5	18.0	19.9
DS-GR 12/8/8-S	12	8	8	S 630 (2700)	24	19	19	17	38	37	37	21.5	22.0	22.0	25.1
DS-GR 12/8/12-S	12	8	12	S 630 (2700)	24	19	24	17	38	38	37	21.5	21.5	22.0	26.6
DS-GR 12/10/12-S	12	10	12	S 630 (2700)	24	22	24	17	38	38	38	21.5	21.5	21.5	27.5
DS-GR 12/16/12-S	12	16	12	S 630 (2700)	24	30	24	24	42	42	43	25.5	25.5	24.5	32.9
DS-GR 16/6/16-S	16	6	16	S 630 (2700)	30	17	30	24	43	43	41	24.5	24.5	26.0	33.3
DS-GR 16/8/16-S	16	8	16	S 630 (2700)	30	19	30	24	43	43	41	24.5	24.5	26.0	33.2
DS-GR 16/10/16-S	16	10	16	S 630 (2700)	30	22	30	24	43	43	42	24.5	24.5	25.5	34.8
DS-GR 16/12/16-S	16	12	16	S 630 (2700)	30	24	30	24	43	43	42	24.5	24.5	25.5	35.6
DS-GR 16/20/16-S	16	20	16	S 400 (1700)	30	36	30	27	47	47	48	28.5	28.5	26.5	50.5
DS-GR 20/10/20-S	20	10	20	S 400 (1700)	36	22	36	27	48	48	46	26.5	26.5	29.5	51.7
DS-GR 20/12/20-S	20	12	20	S 400 (1700)	36	24	36	27	48	48	46	26.5	26.5	29.5	52.4
DS-GR 20/16/20-S	20	16	20	S 400 (1700)	36	30	36	27	48	48	47	26.5	26.5	28.5	54.2
DS-GR 20/25/20-S	20	25	20	S 400 (1700)	36	46	36	36	53	53	54	31.5	31.5	30.0	89.1
DS-GR 25/16/25-S	25	16	25	S 400 (1700)	46	30	46	36	54	54	52	30.0	30.0	33.5	96.6
DS-GR 25/20/25-S	25	20	25	S 400 (1700)	46	36	46	36	54	54	53	30.0	30.0	31.5	99.8
DS-GR 25/30/25-S	25	30	25	S 400 (1700)	46	50	46	41	61	61	62	37.0	37.0	35.5	139.4

$L_1+L_2+L_3$ = approximate length with nut tightened

Please see "Engineering and technical data - Selecting the correct tube fitting" for more information on pressure.

PIPE SCREW JOINTS H EQUAL CROSSES

THE WORLD OF TUBE FITTINGS

H EQUAL CROSSES

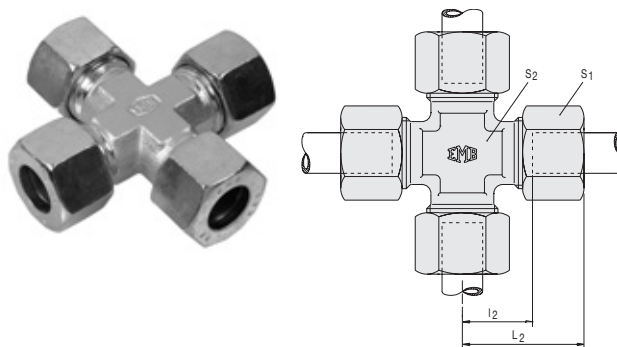

description	pipe OD	PN series	S ₁	S ₂	L ₂	l ₂	kg / 100 pcs
DS-H 6-L	6	L 500 (2200)	14	12	27	12.0	7.7
DS-H 8-L	8	L 500 (2200)	17	12	29	14.0	10.9
DS-H 10-L	10	L 500 (2200)	19	14	30	15.0	15.5
DS-H 12-L	12	L 400 (1700)	22	17	32	17.0	19.2
DS-H 15-L	15	L 400 (1700)	27	19	36	21.0	31.1
DS-H 18-L	18	L 400 (1700)	32	24	40	23.5	48.3
DS-H 22-L	22	L 250 (1100)	36	27	44	27.5	72.4
DS-H 28-L	28	L 250 (1100)	41	36	47	30.5	101.2
DS-H 35-L	35	L 250 (1100)	50	41	56	34.5	122.8
DS-H 42-L	42	L 250 (1100)	60	50	63	40.0	175.6
DS-H 6-S	6	S 800 (3400)	17	12	31	16.0	12.3
DS-H 8-S	8	S 800 (3400)	19	14	32	17.0	14.8
DS-H 10-S	10	S 800 (3400)	22	17	34	17.5	23.0
DS-H 12-S	12	S 630 (2700)	24	17	38	21.5	28.2
DS-H 14-S	14	S 630 (2700)	27	19	40	22.0	35.4
DS-H 16-S	16	S 630 (2700)	30	24	43	24.5	45.1
DS-H 20-S	20	S 400 (1700)	36	27	48	26.5	70.4
DS-H 25-S	25	S 400 (1700)	46	36	54	30.0	125.7
DS-H 30-S	30	S 400 (1700)	50	41	62	35.5	150.3
DS-H 38-S	38	S 400 (1700)	60	50	72	41.0	205.1

L₂ = approximate length with nut tightened

Please see "Engineering and technical data - Selecting the correct tube fitting" for more information on pressure.

PIPE SCREW JOINTS K STRAIGHT BULKHEAD CONNECTIONS

K STRAIGHT BULKHEAD CONNECTIONS

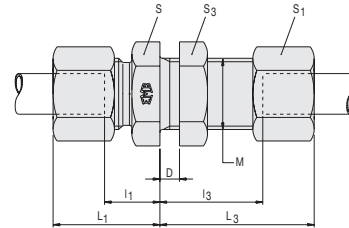

description	pipe OD	PN series	S	S ₁	S ₃	L ₁	l ₁	Dmax	L ₃	l ₃	M	kg / 100 pcs
DS-K 6-L	6	L 500 (2200)	17	14	17	22	7.0	16	42	27.0	M 12x1.5	6.7
DS-K 8-L	8	L 500 (2200)	19	17	19	23	8.0	16	42	27.0	M 14x1.5	8.4
DS-K 10-L	10	L 500 (2200)	22	19	22	25	10.0	16	43	28.0	M 16x1.5	11.0
DS-K 12-L	12	L 400 (1700)	24	22	24	25	10.0	16	44	29.0	M 18x1.5	13.3
DS-K 15-L	15	L 400 (1700)	27	27	30	27	12.0	16	46	31.0	M 22x1.5	22.8
DS-K 18-L	18	L 400 (1700)	32	32	36	30	13.5	16	49	32.5	M 26x1.5	33.2
DS-K 22-L	22	L 250 (1100)	36	36	41	33	16.5	16	51	34.5	M 30x2	41.5
DS-K 28-L	28	L 250 (1100)	41	41	46	35	18.5	16	52	35.5	M 36x2	52.5
DS-K 35-L	35	L 250 (1100)	50	50	55	40	18.5	16	58	36.5	M 45x2	80.0
DS-K 42-L	42	L 250 (1100)	60	60	65	42	19.0	16	59	36.0	M 52x2	119.3
DS-K 6-S	6	S 800 (3400)	19	17	19	27	12.0	16	44	29.0	M 14x1.5	9.6
DS-K 8-S	8	S 800 (3400)	22	19	22	28	13.0	16	44	29.0	M 16x1.5	12.4
DS-K 10-S	10	S 800 (3400)	24	22	24	31	14.5	16	46	29.5	M 18x1.5	18.1
DS-K 12-S	12	S 630 (2700)	27	24	27	31	14.5	16	47	30.5	M 20x1.5	21.0
DS-K 14-S	14	S 630 (2700)	30	27	30	35	17.0	16	50	32.0	M 22x1.5	29.0
DS-K 16-S	16	S 630 (2700)	32	30	32	35	16.5	16	50	31.5	M 24x1.5	31.0
DS-K 20-S	20	S 400 (1700)	41	36	41	39	17.5	16	55	33.5	M 30x2	54.5
DS-K 25-S	25	S 400 (1700)	46	46	46	44	20.0	16	59	35.0	M 36x2	89.0
DS-K 30-S	30	S 400 (1700)	50	50	50	48	21.5	16	64	37.5	M 42x2	107.7
DS-K 38-S	38	S 400 (1700)	65	60	65	53	22.0	16	68	37.0	M 52x2	173.0

L_1+L_3 = approximate length with nut tightened

Please see "Engineering and technical data - Selecting the correct tube fitting" for more information on pressure.

PIPE SCREW JOINTS L BULKHEAD ELBOW CONNECTIONS

THE WORLD OF TUBE FITTINGS

L BULKHEAD ELBOW CONNECTIONS

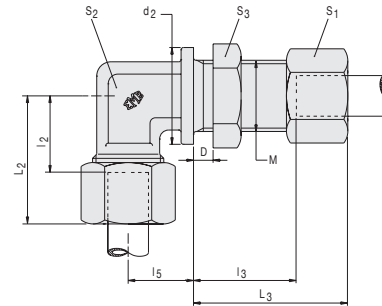

description	pipe OD	PN series	S ₁	S ₂	S ₃	L ₂	l ₂	l ₅	Dmax	L ₃	l ₃	d ₂	M	kg / 100 pcs
DS-L 6-L	6	L 500 (2200)	14	12	17	27	12.0	14	16	42	27.0	17	M 12x1.5	7.5
DS-L 8-L	8	L 500 (2200)	17	12	19	29	14.0	17	16	42	27.0	19	M 14x1.5	9.9
DS-L 10-L	10	L 500 (2200)	19	14	22	30	15.0	18	16	43	28.0	22	M 16x1.5	12.0
DS-L 12-L	12	L 400 (1700)	22	17	24	32	17.0	20	16	44	29.0	24	M 18x1.5	15.0
DS-L 15-L	15	L 400 (1700)	27	19	30	36	21.0	23	16	46	31.0	27	M 22x1.5	25.0
DS-L 18-L	18	L 400 (1700)	32	24	36	40	23.5	24	16	49	32.5	32	M 26x1.5	35.5
DS-L 22-L	22	L 250 (1100)	36	27	41	44	27.5	30	16	51	34.5	36	M 30x2	46.5
DS-L 28-L	28	L 250 (1100)	41	36	46	47	30.5	34	16	52	35.5	42	M 36x2	64.0
DS-L 35-L	35	L 250 (1100)	50	41	55	56	34.5	39	16	58	36.5	50	M 45x2	99.4
DS-L 42-L	42	L 250 (1100)	60	50	65	63	40.0	43	16	59	36.0	60	M 52x2	149.0
DS-L 6-S	6	S 800 (3400)	17	12	19	31	16.0	17	16	44	29.0	19	M 14x1.5	10.5
DS-L 8-S	8	S 800 (3400)	19	14	22	32	17.0	18	16	44	29.0	22	M 16x1.5	14.0
DS-L 10-S	10	S 800 (3400)	22	17	24	34	17.5	20	16	46	29.5	24	M 18x1.5	19.0
DS-L 12-S	12	S 630 (2700)	24	17	27	38	21.5	21	16	47	30.5	27	M 20x1.5	22.5
DS-L 14-S	14	S 630 (2700)	27	19	30	40	22.0	23	16	50	32.0	27	M 22x1.5	30.0
DS-L 16-S	16	S 630 (2700)	30	24	32	43	24.5	24	16	50	31.5	30	M 24x1.5	36.5
DS-L 20-S	20	S 400 (1700)	36	27	41	48	26.5	30	16	55	33.5	36	M 30x2	58.0
DS-L 25-S	25	S 400 (1700)	46	36	46	54	30.0	34	16	59	35.0	42	M 36x2	100.0
DS-L 30-S	30	S 400 (1700)	50	41	50	62	35.5	39	16	64	37.5	50	M 42x2	130.0
DS-L 38-S	38	S 400 (1700)	60	50	65	72	41.0	43	16	68	37.0	60	M 52x2	197.0

L_2+L_3 = approximate length with nut tightened

Please see "Engineering and technical data - Selecting the correct tube fitting" for more information on pressure.

PIPE SCREW JOINTS N WELDING BULKHEAD CONNECTIONS

N WELDING BULKHEAD CONNECTIONS

Socket material: steel, fusion weldable.

Socket surface: bright, oiled.

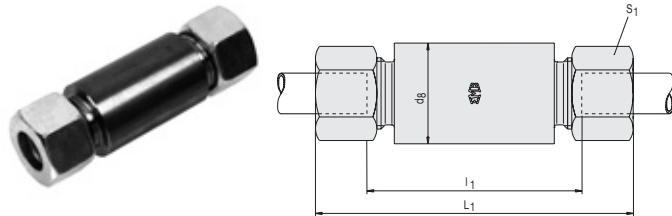

description	pipe OD	PN series	S ₁	L ₁	l ₁	d ₈	kg / 100 pcs
DS-N 6-L	6	L 500 (2200)	14	85	56	18	13.1
DS-N 8-L	8	L 500 (2200)	17	85	56	20	16.2
DS-N 10-L	10	L 500 (2200)	19	87	58	22	19.5
DS-N 12-L	12	L 400 (1700)	22	87	58	25	24.1
DS-N 15-L	15	L 400 (1700)	27	100	70	28	35.3
DS-N 18-L	18	L 400 (1700)	32	101	69	32	46.9
DS-N 22-L	22	L 250 (1100)	36	105	73	36	58.2
DS-N 28-L	28	L 250 (1100)	41	106	73	40	66.0
DS-N 35-L	35	L 250 (1100)	50	114	71	50	102.9
DS-N 42-L	42	L 250 (1100)	60	115	70	60	148.8
DS-N 6-S	6	S 800 (3400)	17	89	60	20	16.9
DS-N 8-S	8	S 800 (3400)	19	89	60	22	20.4
DS-N 10-S	10	S 800 (3400)	22	91	59	25	27.0
DS-N 12-S	12	S 630 (2700)	24	91	59	28	33.1
DS-N 14-S	14	S 630 (2700)	27	107	72	30	44.7
DS-N 16-S	16	S 630 (2700)	30	107	71	35	57.8
DS-N 20-S	20	S 400 (1700)	36	114	71	38	73.2
DS-N 25-S	25	S 400 (1700)	46	120	72	45	114.6
DS-N 30-S	30	S 400 (1700)	50	126	73	50	134.4
DS-N 38-S	38	S 400 (1700)	60	133	72	60	191.3

L₁ = approximate length with nut tightened

Please see "Engineering and technical data - Selecting the correct tube fitting" for more information on pressure.

PIPE SCREW JOINTS V WELDING BOSSES

THE WORLD OF TUBE FITTINGS

V WELDING BOSSES

Socket material: steel, fusion weldable.

Socket surface: bright, oiled.

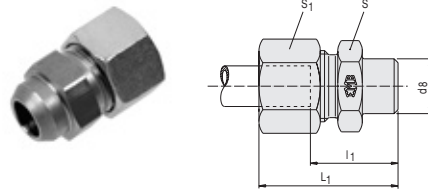

description	pipe OD	PN series	S	S ₁	L ₁	l ₁	d ₈	kg / 100 pcs
DS-V 6-L	6	L 500 (2200)	12	14	29	14.0	10	2.5
DS-V 8-L	8	L 500 (2200)	14	17	31	16.0	12	3.6
DS-V 10-L	10	L 500 (2200)	17	19	33	18.0	14	4.7
DS-V 12-L	12	L 400 (1700)	19	22	33	18.0	16	6.3
DS-V 15-L	15	L 400 (1700)	22	27	37	22.0	19	8.4
DS-V 18-L	18	L 400 (1700)	27	32	40	23.5	22	13.9
DS-V 22-L	22	L 250 (1100)	32	36	45	28.5	27	18.1
DS-V 28-L	28	L 250 (1100)	41	41	47	30.5	32	30.2
DS-V 35-L	35	L 250 (1100)	46	50	54	32.5	40	37.7
DS-V 42-L	42	L 250 (1100)	55	60	58	35.0	46	64.1
DS-V 6-S	6	S 800 (3400)	14	17	34	19.0	11	3.2
DS-V 8-S	8	S 800 (3400)	17	19	36	21.0	13	4.9
DS-V 10-S	10	S 800 (3400)	19	22	39	22.5	15	7.2
DS-V 12-S	12	S 630 (2700)	22	24	41	24.5	17	8.3
DS-V 14-S	14	S 630 (2700)	24	27	45	27.0	19	10.8
DS-V 16-S	16	S 630 (2700)	27	30	45	26.5	21	14.4
DS-V 20-S	20	S 400 (1700)	32	36	51	29.5	26	21.8
DS-V 25-S	25	S 400 (1700)	41	46	56	32.0	31	37.7
DS-V 30-S	30	S 400 (1700)	46	50	62	35.5	36	44.9
DS-V 38-S	38	S 400 (1700)	55	60	69	38.0	44	68.4

L₁ = approximate length with nut tightened

Please see "Engineering and technical data - Selecting the correct tube fitting" for more information on pressure.

PIPE SCREW JOINTS BS WELDING ELBOWS

BS WELDING ELBOWS

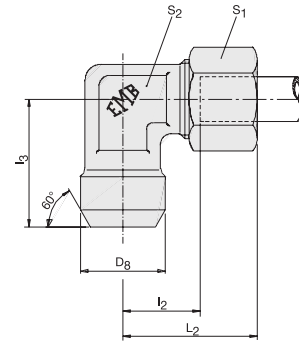

description	pipe OD	PN series	S ₁	S ₂	L ₂	l ₂	l ₃	d ₈	kg / 100 pcs
DS-BS 6-L	6	L 500	14	12	27	12.0	19	10	3.0
DS-BS 8-L	8	L 500	17	12	29	14.0	23	12	3.6
DS-BS 10-L	10	L 500	19	14	30	15.0	24	14	5.2
DS-BS 12-L	12	L 500	22	17	32	17.0	25	16	7.3
DS-BS 15-L	15	L 400	27	19	36	21.0	30	19	12.0
DS-BS 18-L	18	L 400	32	24	40	23.5	33	22	16.6
DS-BS 22-L	22	L 250	36	27	44	27.5	37	27	24.6
DS-BS 28-L	28	L 250	41	36	47	30.5	42	32	34.7
DS-BS 35-L	35	L 250	50	41	56	34.5	49	40	61.2
DS-BS 42-L	42	L 250	60	50	63	40.0	57	46	84.6
DS-BS 6-S	6	S 800	17	12	31	16.0	23	11	5.2
DS-BS 8-S	8	S 800	19	14	32	17.0	24	13	6.4
DS-BS 10-S	10	S 800	22	17	34	17.5	25	15	9.7
DS-BS 12-S	12	S 630	24	17	38	21.5	29	17	10.8
DS-BS 14-S	14	S 630	27	19	40	22.0	30	19	15.3
DS-BS 16-S	16	S 630	30	24	43	24.5	33	21	18.9
DS-BS 20-S	20	S 400	36	27	48	26.5	37	26	30.3
DS-BS 25-S	25	S 400	46	36	54	30.0	42	31	58.0
DS-BS 30-S	30	S 400	50	41	62	35.5	49	36	74.4
DS-BS 38-S	38	S 400	60	50	72	41.0	57	44	98.9

Please see "Engineering and technical data - Selecting the correct tube fitting" for more information on pressure.

THE WORLD OF TUBE FITTINGS
INTEGRATED FLUID POWER SOLUTIONS



COUPLINGS



COUPLINGS

BANJO COUPLING

SBD BANJO COUPLING

THE WORLD OF TUBE FITTINGS

SBD BANJO COUPLING BSP

BSP parallel.

Bodies from forgings with turned sealing shoulder.

Tubes O.D. L 18, L 22, S 16 and S 20 with sealing washer.

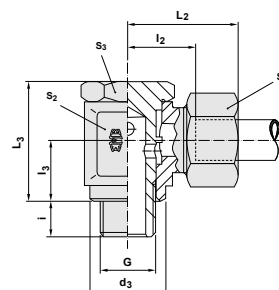

description	pipe OD	PB series	S ₁	S ₂	S ₃	L ₂	l ₂	l ₃	L ₃	d ₃	i	G	MA* Nm	kg / 100 pcs
SBD 4-RLL	4	LL 100	10	14	14	21	11.5	10.0	21.0	14.5	6	G 1/8" A	20	3.0
SBD 6-RLL	6	LL 100	12	14	14	22	10.0	10.0	21.0	14.5	6	G 1/8" A	20	3.3
SBD 8-RLL	8	LL 100	14	14	14	23	12.0	10.0	21.0	14.5	6	G 1/8" A	20	3.5
DS-SBD 6-RL	6	L 250	14	14	14	25	10.5	10.0	21.0	14.5	6	G 1/8" A	20	4.0
DS-SBD 8-RL	8	L 250	17	19	19	28	13.0	13.0	27.0	18.5	9	G 1/4" A	45	7.7
DS-SBD 10-RL	10	L 250	19	19	19	29	14.0	13.0	27.0	18.5	9	G 1/4" A	45	8.5
DS-SBD 12-RL	12	L 250	22	22	22	30	15.5	15.0	32.0	22.5	9	G 3/8" A	70	14.2
DS-SBD 15-RL	15	L 250	27	27	27	34	19.0	18.0	37.5	26.5	11	G 1/2" A	100	19.5
DS-SBD 18-RL	18	L 160	32	30	27	37	20.5	21.5	44.0	26.0	11	G 1/2" A	100	20.5
DS-SBD 22-RL	22	L 160	36	36	32	42	25.5	24.0	49.0	32.0	13	G 3/4" A	140	38.3
DS-SBD 6-RS	6	S 250	17	19	19	30	15.0	13.0	27.0	18.5	9	G 1/4" A	45	8.0
DS-SBD 8-RS	8	S 250	19	19	19	30	15.0	13.0	27.0	18.5	9	G 1/4" A	45	9.5
DS-SBD 10-RS	10	S 250	22	22	22	32	16.0	15.0	32.0	22.5	9	G 3/8" A	70	12.0
DS-SBD 12-RS	12	S 250	24	24	24	33	17.0	18.0	37.0	22.5	9	G 3/8" A	70	14.5
DS-SBD 14-RS	14	S 250	27	27	27	38	20.0	18.0	37.0	26.5	11	G 1/2" A	100	21.5
DS-SBD 16-RS	16	S 160	30	30	27	40	21.5	21.5	44.0	26.0	11	G 1/2" A	100	27.7
DS-SBD 20-RS	20	S 160	36	36	32	46	24.5	24.0	49.0	32.0	13	G 3/4" A	140	42.5

L₂ = approximate length with nut tightened

* Recommended tightening torques for stud threads G, with mating material steel

Please see "Engineering and technical data - Selecting the correct tube fitting" for more information on pressure.

COUPLINGS

BANJO COUPLING

SBD BANJO COUPLING

SBD BANJO COUPLING METRIC

Metric parallel.

Bodies from forgings with turned sealing shoulder.

Tubes O.D. L 18, L 22, S 16 and S 20 with sealing washer.

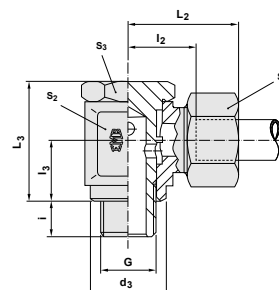

description	pipe OD	PB series	S ₁	S ₂	S ₃	L ₂	l ₂	l ₃	L ₃	d ₃	i	G	MA* Nm	kg / 100 pcs
SBD 4-MLL	4	LL 100	10	12	12	20	10.5	8.0	17.0	12.5	6	M 8x1	10	2.8
SBD 6-MLL	6	LL 100	12	14	14	22	10.0	10.0	21.0	14.5	6	M 10x1	25	3.3
SBD 8-MLL	8	LL 100	14	14	14	23	12.0	10.0	21.0	14.5	6	M 10x1	25	3.5
DS-SBD 6-ML	6	L 250	14	14	14	25	10.5	10.0	21.0	14.5	6	M 10x1	25	3.8
DS-SBD 8-ML	8	L 250	17	17	17	27	12.0	12.0	25.0	17.5	9	M 12x1.5	40	7.0
DS-SBD 10-ML	10	L 250	19	19	19	29	14.0	13.0	27.0	19.5	9	M 14x1.5	55	8.0
DS-SBD 12-ML	12	L 250	22	22	22	30	15.5	15.0	32.0	21.5	9	M 16x1.5	65	11.2
DS-SBD 15-ML	15	L 250	27	24	24	33	17.5	18.0	37.5	23.5	9	M 18x1.5	90	16.5
DS-SBD 18-ML	18	L 160	32	30	27	37	20.5	21.5	44.0	27.0	11	M 22x1.5	130	26.5
DS-SBD 22-ML	22	L 160	36	36	32	42	25.5	24.0	49.0	31.0	13	M 26x1.5	140	35.0
DS-SBD 6-MS	6	S 250	17	17	17	29	14.0	12.0	25.0	17.5	9	M 12x1.5	40	6.7
DS-SBD 8-MS	8	S 250	19	19	19	30	15.0	13.0	27.0	19.5	9	M 14x1.5	55	9.3
DS-SBD 10-MS	10	S 250	22	22	22	32	16.0	15.0	32.0	21.5	9	M 16x1.5	65	13.0
DS-SBD 12-MS	12	S 250	24	24	24	33	17.0	18.0	37.0	23.5	9	M 18x1.5	90	16.8
DS-SBD 14-MS	14	S 250	27	27	27	38	20.0	18.0	37.0	25.5	11	M 20x1.5	120	21.5
DS-SBD 16-MS	16	S 160	30	30	27	40	21.5	21.5	44.0	27.0	11	M 22x1.5	130	27.5
DS-SBD 20-MS	20	S 160	36	36	32	46	24.5	24.0	49.0	32.0	13	M 27x2	150	42.5

L₂ = approximate length with nut tightened

* Recommended tightening torques for stud threads G, with mating material steel

Please see "Engineering and technical data - Selecting the correct tube fitting" for more information on pressure.

COUPLINGS

BANJO COUPLING

SBD BANJO COUPLING

THE WORLD OF TUBE FITTINGS

SBD BANJO COUPLING COMPONENTS BSP

BSP parallel.

Order codes single parts.

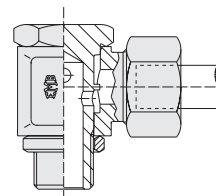

description	pipe OD	series	Housing	Hollow screw	Seal-edge ring
SBD 4-RLL	4	LL	XSBD 4-RLL/K	SHD R 1/8"	turned sealing shoulder
SBD 6-RLL	6	LL	XSBD 6-RLL/K	SHD R 1/8"	turned sealing shoulder
SBD 8-RLL	8	LL	XSBD 8-RLL/K	SHD R 1/8"	turned sealing shoulder
DS-SBD 6-RL	6	L	XSBD 6-RL/K	SHD R 1/8"	turned sealing shoulder
DS-SBD 8-RL	8	L	XSBD 8-RL/K	SHD R 1/4"	turned sealing shoulder
DS-SBD 10-RL	10	L	XSBD 10-RL/K	SHD R 1/4"	turned sealing shoulder
DS-SBD 12-RL	12	L	XSBD 12-RL/K	SHD R 3/8"	turned sealing shoulder
DS-SBD 15-RL	15	L	XSBD 15-RL/K	SHD R 1/2"	turned sealing shoulder
DS-SBD 18-RL	18	L	XSBD 18-RL/K	SHD R 1/2" / 55	DKAD R 1/2"
DS-SBD 22-RL	22	L	XSBD 22-RL/K	SHD R 3/4"	DKAD R 3/4"
DS-SBD 6-RS	6	S	XSBD 6-RS/K	SHD R 1/4"	turned sealing shoulder
DS-SBD 8-RS	8	S	XSBD 8-RS/K	SHD R 1/4"	turned sealing shoulder
DS-SBD 10-RS	10	S	XSBD 10-RS/K	SHD R 3/8"	turned sealing shoulder
DS-SBD 12-RS	12	S	XSBD 12-RS/K	SHD R 3/8" 24	turned sealing shoulder
DS-SBD 14-RS	14	S	XSBD 14-RS/K	SHD R 1/2"	turned sealing shoulder
DS-SBD 16-RS	16	S	XSBD 16-RS/K	SHD R 1/2" 55	DKAD R 1/2"
DS-SBD 20-RS	20	S	XSBD 20-RS/K	SHD R 3/4"	DKAD R 3/4"

Please see "Engineering and technical data - Selecting the correct tube fitting" for more information on pressure.

COUPLINGS

BANJO COUPLING

SBD BANJO COUPLING

SBD BANJO COUPLING COMPONENTS METRIC

Metric parallel.

Order codes single parts.

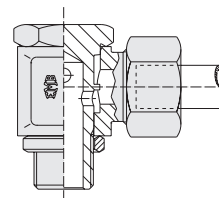

description	pipe OD	series	Housing	Hollow screw	Seal-edge ring
SBD 4-MLL	4	LL	XSBD 4-MLL/K	SHD M 8x1	turned sealing shoulder
SBD 6-MLL	6	LL	XSBD 6-MLL/K	SHD M 10x1	turned sealing shoulder
SBD 8-MLL	8	LL	XSBD 8-MLL/K	SHD M 10x1	turned sealing shoulder
DS-SBD 6-ML	6	L	XSBD 6-ML/K	SHD M 10x1	turned sealing shoulder
DS-SBD 8-ML	8	L	XSBD 8-ML/K	SHD M 12x1.5	turned sealing shoulder
DS-SBD 10-ML	10	L	XSBD 10-ML/K	SHD M 14x1.5	turned sealing shoulder
DS-SBD 12-ML	12	L	XSBD 12-ML/K	SHD M 16x1.5	turned sealing shoulder
DS-SBD 15-ML	15	L	XSBD 15-ML/K	SHD M 18x1.5	turned sealing shoulder
DS-SBD 18-ML	18	L	XSBD 18-ML/K	SHD M 22x1.5	DKAD M 22
DS-SBD 22-ML	22	L	XSBD 22-ML/K	SHD M 26x1.5	DKAD M 26
DS-SBD 6-MS	6	S	XSBD 6-MS/K	SHD M 12x1.5	turned sealing shoulder
DS-SBD 8-MS	8	S	XSBD 8-MS/K	SHD M 14x1.5	turned sealing shoulder
DS-SBD 10-MS	10	S	XSBD 10-MS/K	SHD M 16x1.5	turned sealing shoulder
DS-SBD 12-MS	12	S	XSBD 12-MS/K	SHD M 18x1.5	turned sealing shoulder
DS-SBD 14-MS	14	S	XSBD 14-MS/K	SHD M 20x1.5	turned sealing shoulder
DS-SBD 16-MS	16	S	XSBD 16-MS/K	SHD M 22x1.5	DKAD M 22
DS-SBD 20-MS	20	S	XSBD 20-MS/K	SHD M 27x2	DKAD M 27

Please see "Engineering and technical data - Selecting the correct tube fitting" for more information on pressure.

COUPLINGS

BANJO COUPLING

SB BANJO COUPLING CHOKE-FREE

THE WORLD OF TUBE FITTINGS

SB BANJO COUPLING CHOKE-FREE BSP

BSP parallel.

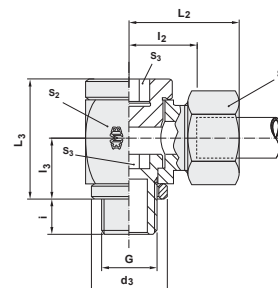

description	pipe OD	PB series	S ₁	S ₂	S ₃	L ₂	l ₂	l ₃	L ₃	d ₃	i	G	kg / 100 pcs
DS-SB 6-RL	6	L 250	14	18	6	27	12.5	12.0	24	14	8	G 1/8" A	5.9
DS-SB 8-RL	8	L 250	17	22	8	29	14.5	16.0	30	18	12	G 1/4" A	10.5
DS-SB 10-RL	10	L 250	19	22	8	30	15.5	16.0	30	18	12	G 1/4" A	11.3
DS-SB 12-RL	12	L 250	22	27	10	33	18.0	18.0	37	22	12	G 3/8" A	18.0
DS-SB 15-RL	15	L 250	27	32	12	37	22.0	21.0	42	26	14	G 1/2" A	24.7
DS-SB 18-RL	18	L 100	32	36	12	38	21.5	23.0	46	26	14	G 1/2" A	26.9
DS-SB 22-RL	22	L 100	36	46	17	45	28.5	28.0	58	32	16	G 3/4" A	54.6
DS-SB 28-RL	28	L 100	41	50	22	48	31.5	30.5	64	39	18	G 1" A	83.0
DS-SB 35-RL	35	L 100	50	60	27	57	35.5	36.0	76	49	20	G 1 1/4" A	117.3
DS-SB 42-RL	42	L 100	60	70	32	63	40.0	41.0	85	55	22	G 1 1/2" A	224.4
DS-SB 6-RS	6	S 400*	17	22	8	31	16.5	16.0	30	18	12	G 1/4" A	10.9
DS-SB 8-RS	8	S 400*	19	22	8	31	16.5	16.0	30	18	12	G 1/4" A	11.4
DS-SB 10-RS	10	S 400*	22	27	10	35	18.5	18.0	37	22	12	G 3/8" A	19.0
DS-SB 12-RS	12	S 400*	24	27	10	35	18.5	18.0	37	22	12	G 3/8" A	19.6
DS-SB 14-RS	14	S 400*	27	32	12	41	23.0	21.0	42	26	14	G 1/2" A	29.7
DS-SB 16-RS	16	S 400*	30	36	12	41	22.5	23.0	46	26	14	G 1/2" A	30.7
DS-SB 20-RS	20	S 400*	36	46	17	49	27.5	28.0	58	32	16	G 3/4" A	75.3
DS-SB 25-RS	25	S 250*	46	50	22	55	31.0	30.5	64	39	18	G 1" A	101.9
DS-SB 30-RS	30	S 250*	50	60	27	63	36.5	36.0	76	49	20	G 1 1/4" A	158.0
DS-SB 38-RS	38	S 250*	60	70	32	72	41.0	41.0	85	55	22	G 1 1/2" A	243.2

L₂ = approximate length with nut tightened

* Security factor minimum 1.6

Please see "Engineering and technical data - Selecting the correct tube fitting" for more information on pressure.

COUPLINGS

BANJO COUPLING

SB BANJO COUPLING CHOKE-FREE

SB BANJO COUPLING CHOKE-FREE METRIC

Metric parallel.

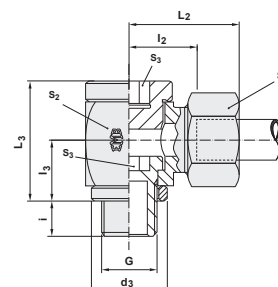

description	pipe OD	PB series	S ₁	S ₂	S ₃	L ₂	l ₂	l ₃	L ₃	d ₃	i	G	kg / 100 pcs
DS-SB 6-ML	6	L 250	14	18	6	27	12.5	12.0	24	14	8	M 10x1	6.2
DS-SB 8-ML	8	L 250	17	22	6	29	14.5	15.0	30	17	12	M 12x1.5	10.0
DS-SB 10-ML	10	L 250	19	22	8	30	15.5	16.0	30	19	12	M 14x1.5	11.4
DS-SB 12-ML	12	L 250	22	27	10	33	18.0	18.0	37	21	12	M 16x1.5	17.9
DS-SB 15-ML	15	L 250	27	30	12	36	21.0	20.0	40	23	12	M 18x1.5	24.1
DS-SB 18-ML	18	L 100	32	36	14	38	21.5	23.0	46	27	14	M 22x1.5	30.1
DS-SB 22-ML	22	L 100	36	41	17	42	26.0	25.0	51	31	16	M 26x1.5	39.9
DS-SB 28-ML	28	L 100	41	50	22	48	31.5	30.5	64	39	18	M 33x2	82.5
DS-SB 35-ML	35	L 100	50	60	27	57	35.5	36.0	76	49	20	M 42x2	116.1
DS-SB 42-ML	42	L 100	60	70	32	63	40.0	41.0	85	55	22	M 48x2	224.0
DS-SB 6-MS	6	S 400*	17	22	6	31	16.5	15.0	30	17	12	M 12x1.5	9.2
DS-SB 8-MS	8	S 400*	19	22	8	31	16.5	16.0	30	19	12	M 14x1.5	11.6
DS-SB 10-MS	10	S 400*	22	27	10	35	18.5	18.0	37	21	12	M 16x1.5	18.9
DS-SB 12-MS	12	S 400*	24	30	12	37	20.5	20.0	41	23	12	M 18x1.5	24.0
DS-SB 14-MS	14	S 400*	27	32	12	41	23.0	21.0	42	25	14	M 20x1.5	30.2
DS-SB 16-MS	16	S 400*	30	36	14	41	22.5	23.0	46	27	14	M 22x1.5	38.9
DS-SB 20-MS	20	S 400*	36	46	17	49	27.5	28.0	58	32	16	M 27x2	75.8
DS-SB 25-MS	25	S 250*	46	50	22	55	31.0	30.5	64	39	18	M 33x2	101.4
DS-SB 30-MS	30	S 250*	50	60	27	63	36.5	36.0	76	49	20	M 42x2	156.8
DS-SB 38-MS	38	S 250*	60	70	32	72	41.0	41.0	85	55	22	M 48x2	242.8

L₂ = approximate length with nut tightened

* Security factor minimum 1.6

Please see "Engineering and technical data - Selecting the correct tube fitting" for more information on pressure.

COUPLINGS

BANJO COUPLING

SBE BANJO COUPLING HIGH PRESSURE

THE WORLD OF TUBE FITTINGS

SBE BANJO COUPLING HIGH PRESSURE BSP DKA

BSP parallel.

Edge sealing ring DKA match "narrow" counter bore according to DIN 3852/d4.

O-ring NBR (e.g. Perbunan), FPM (e.g. Viton) upon request.

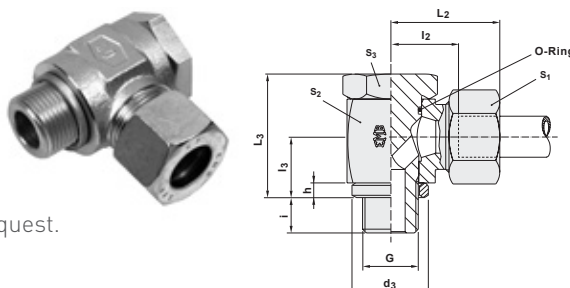

description	pipe OD	PB series	S ₁	S ₂	S ₃	L ₂	l ₂	l ₃	L ₃	d ₃	i	h	G	MA* Nm	kg / 100 pcs
DS-SBE 6-RL	6	L 500	14	17	17	27	24	12.0	10.5	14	8	2.5	G 1/8" A	20	6.4
DS-SBE 8-RL	8	L 500	17	22	19	29	30	14.5	14.0	18	12	3.0	G 1/4" A	50	11.7
DS-SBE 10-RL	10	L 500	19	22	19	30	30	15.5	14.0	18	12	3.0	G 1/4" A	50	12.3
DS-SBE 12-RL	12	L 400	22	27	24	33	36	18.0	16.5	22	12	3.0	G 3/8" A	75	20.7
DS-SBE 15-RL	15	L 400	27	32	30	37	45	21.5	21.5	26	14	4.5	G 1/2" A	130	35.9
DS-SBE 18-RL	18	L 400	32	32	30	37	45	21.0	21.5	26	14	4.5	G 1/2" A	130	38.4
DS-SBE 22-RL	22	L 250	36	41	36	44	53	27.5	24.0	32	16	3.5	G 3/4" A	250	66.6
DS-SBE 28-RL	28	L 250	41	50	46	49	66	32.0	30.5	39	18	3.5	G 1" A	350	112.7
DS-SBE 35-RL	35	L 250	50	60	55	58	76	36.0	35.5	49	20	3.5	G 1 1/4" A	600	166.3
DS-SBE 42-RL	42	L 250	60	70	60	63	87	40.5	40.5	55	22	3.5	G 1 1/2" A	800	245.9
DS-SBE 6-RS	6	S 500	17	22	19	31	30	16.5	14.0	18	12	3.0	G 1/4" A	50	12.6
DS-SBE 8-RS	8	S 500	19	22	19	31	30	16.5	14.0	18	12	3.0	G 1/4" A	50	12.9
DS-SBE 10-RS	10	S 500	22	27	24	35	36	18.5	16.5	22	12	3.0	G 3/8" A	75	22.0
DS-SBE 12-RS	12	S 500	24	27	24	35	36	18.5	16.5	22	12	3.0	G 3/8" A	75	22.5
DS-SBE 14-RS	14	S 500	27	32	30	40	45	22.5	21.5	26	14	4.5	G 1/2" A	130	37.5
DS-SBE 16-RS	16	S 500	30	32	30	40	45	22.0	21.5	26	14	4.5	G 1/2" A	130	39.3
DS-SBE 20-RS	20	S 400	36	41	36	48	53	26.5	24.0	32	16	3.5	G 3/4" A	250	69.2
DS-SBE 25-RS	25	S 400	46	50	46	56	66	31.5	30.5	39	18	3.5	G 1" A	350	128.4
DS-SBE 30-RS	30	S 400	50	60	55	64	76	37.0	35.5	49	20	3.5	G 1 1/4" A	600	176.3
DS-SBE 38-RS	38	S 400	60	70	60	72	87	41.5	40.5	55	22	3.5	G 1 1/2" A	800	293.0

L₂ = approximate length with nut tightened

* Recommended tightening torques for stud threads G, with mating material steel

Please see "Engineering and technical data - Selecting the correct tube fitting" for more information on pressure.

COUPLINGS

BANJO COUPLING

SBE BANJO COUPLING HIGH PRESSURE

SBE BANJO COUPLING HIGH PRESSURE BSP EDE

BSP parallel.

Sealing ring EDE (vulcanised NBR) for "narrow"
DIN 3852/d4 bore.

O-ring NBR (e.g. Perbunan), FPM (e.g. Viton) upon request.

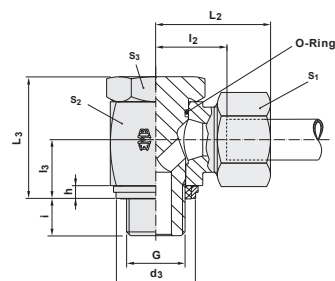

description	pipe OD	PB series	S ₁	S ₂	S ₃	L ₂	L ₁	L ₃	L ₃	D ₉	i	h	G	MA* Nm	kg / 100 pcs
DS-SBE 6-RL/EDE	6	L 500	14	17	17	27	12.0	24	10.5	14.9	8	2.5	G 1/8" A	20	6.4
DS-SBE 8-RL/EDE	8	L 500	17	22	19	29	14.5	30	14.0	18.9	12	3.0	G 1/4" A	50	11.7
DS-SBE 10-RL/EDE	10	L 500	19	22	19	30	15.5	30	14.0	18.9	12	3.0	G 1/4" A	50	12.3
DS-SBE 12-RL/EDE	12	L 400	22	27	24	33	18.0	36	16.5	21.9	12	3.0	G 3/8" A	75	20.7
DS-SBE 15-RL/EDE	15	L 400	27	32	30	37	21.5	45	21.5	26.9	14	4.5	G 1/2" A	130	35.9
DS-SBE 18-RL/EDE	18	L 400	32	32	30	37	21.0	45	21.5	26.9	14	4.5	G 1/2" A	130	38.4
DS-SBE 22-RL/EDE	22	L 250	36	41	36	44	27.5	53	24.0	32.9	16	3.5	G 3/4" A	250	66.6
DS-SBE 28-RL/EDE	28	L 250	41	50	46	49	32.0	66	30.5	39.9	18	3.5	G 1" A	350	112.7
DS-SBE 35-RL/EDE	35	L 250	50	60	55	58	36.0	76	35.5	49.9	20	3.5	G 1 1/4" A	600	166.3
DS-SBE 42-RL/EDE	42	L 250	60	70	60	63	40.5	87	40.5	55.9	22	3.5	G 1 1/2" A	800	245.9
DS-SBE 6-RS/EDE	6	S 500	17	22	19	31	16.5	30	14.0	18.9	12	3.0	G 1/4" A	50	12.6
DS-SBE 8-RS/EDE	8	S 500	19	22	19	31	16.5	30	14.0	18.9	12	3.0	G 1/4" A	50	12.9
DS-SBE 10-RS/EDE	10	S 500	22	27	24	35	18.5	36	16.5	21.9	12	3.0	G 3/8" A	75	22.0
DS-SBE 12-RS/EDE	12	S 500	24	27	24	35	18.5	36	16.5	21.9	12	3.0	G 3/8" A	75	22.5
DS-SBE 14-RS/EDE	14	S 500	27	32	30	40	22.5	45	21.5	26.9	14	4.5	G 1/2" A	130	37.5
DS-SBE 16-RS/EDE	16	S 500	30	32	30	40	22.0	45	21.5	26.9	14	4.5	G 1/2" A	130	39.3
DS-SBE 20-RS/EDE	20	S 400	36	41	36	48	26.5	53	24.0	32.9	16	3.5	G 3/4" A	250	69.2
DS-SBE 25-RS/EDE	25	S 400	46	50	46	56	31.5	66	30.5	39.9	18	3.5	G 1" A	350	128.4
DS-SBE 30-RS/EDE	30	S 400	50	60	55	64	37.0	76	35.5	49.9	20	3.5	G 1 1/4" A	600	176.3
DS-SBE 38-RS/EDE	38	S 400	60	70	60	72	41.5	87	40.5	55.9	22	3.5	G 1 1/2" A	800	293.0

L₂ = approximate length with nut tightened

* Recommended tightening torques for stud threads G, with mating material steel

Please see "Engineering and technical data - Selecting the correct tube fitting" for more information on pressure.

COUPLINGS

BANJO COUPLING

SBE BANJO COUPLING HIGH PRESSURE

THE WORLD OF TUBE FITTINGS

SBE BANJO COUPLING HIGH PRESSURE BSP KDE

BSP parallel.

Metal joint ring KDE.

O-ring NBR (e.g. Perbunan), FPM (e.g. Viton) upon request.

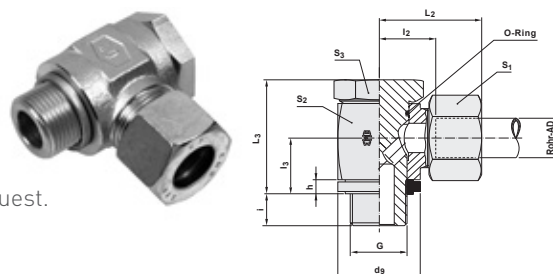

description	pipe OD	PB series	S ₁	S ₂	S ₃	L ₂	l ₂	l ₃	L ₃	D ₉	i	h	G	MA* Nm	kg / 100 pcs
DS-SBE 6-RL/KDE	6	L 500	14	17	17	27	12.0	10.5	24	17	8	2.5	G 1/8" A	20	6.4
DS-SBE 8-RL/KDE	8	L 500	17	22	19	29	14.5	14.0	30	22	12	3.0	G 1/4" A	50	11.9
DS-SBE 10-RL/KDE	10	L 500	19	22	19	30	15.5	14.0	30	22	12	3.0	G 1/4" A	50	12.5
DS-SBE 12-RL/KDE	12	L 400	22	27	24	33	18.0	16.5	36	27	12	3.0	G 3/8" A	75	21.0
DS-SBE 15-RL/KDE	15	L 400	27	32	30	37	21.5	21.5	45	32	14	4.5	G 1/2" A	130	36.5
DS-SBE 18-RL/KDE	18	L 400	32	32	30	37	21.0	21.5	45	32	14	4.5	G 1/2" A	130	39.0
DS-SBE 22-RL/KDE	22	L 250	36	41	36	44	27.5	24.0	53	41	16	3.5	G 3/4" A	250	67.7
DS-SBE 28-RL/KDE	28	L 250	41	50	46	49	32.0	30.5	66	46	18	3.5	G 1" A	350	113.5
DS-SBE 35-RL/KDE	35	L 250	50	60	55	58	36.0	35.5	76	57	20	3.5	G 1 1/4" A	600	167.7
DS-SBE 42-RL/KDE	42	L 250	60	70	60	63	40.5	40.5	87	64	22	3.5	G 1 1/2" A	800	247.7
DS-SBE 6-RS/KDE	6	S 500	17	22	19	31	16.5	14.0	30	22	12	3.0	G 1/4" A	50	12.7
DS-SBE 8-RS/KDE	8	S 500	19	22	19	31	16.5	14.0	30	22	12	3.0	G 1/4" A	50	13.1
DS-SBE 10-RS/KDE	10	S 500	22	27	24	35	18.5	16.5	36	27	12	3.0	G 3/8" A	75	22.2
DS-SBE 12-RS/KDE	12	S 500	24	27	24	35	18.5	16.5	36	27	12	3.0	G 3/8" A	75	22.8
DS-SBE 14-RS/KDE	14	S 500	27	32	30	40	22.5	21.5	45	32	14	4.5	G 1/2" A	130	38.0
DS-SBE 16-RS/KDE	16	S 500	30	32	30	40	22.0	21.5	45	32	14	4.5	G 1/2" A	130	39.9
DS-SBE 20-RS/KDE	20	S 400	36	41	36	48	26.5	24.0	53	41	16	3.5	G 3/4" A	250	70.3
DS-SBE 25-RS/KDE	25	S 400	46	50	46	56	31.5	30.5	66	46	18	3.5	G 1" A	350	129.2
DS-SBE 30-RS/KDE	30	S 400	50	60	55	64	37.0	35.5	76	57	20	3.5	G 1 1/4" A	600	177.7
DS-SBE 38-RS/KDE	38	S 400	60	70	60	72	41.5	40.5	87	64	22	3.5	G 1 1/2" A	800	294.8

L₂ = approximate length with nut tightened

* Recommended tightening torques for stud threads G, with mating material steel

Please see "Engineering and technical data - Selecting the correct tube fitting" for more information on pressure.

COUPLINGS

BANJO COUPLING

SBE BANJO COUPLING HIGH PRESSURE

SBE BANJO COUPLING HIGH PRESSURE METRIC DKA

Metric parallel.

Edge sealing ring DKA match "narrow" counter bore according to DIN 3852/d4.

O-ring NBR (e.g. Perbunan), FPM (e.g. Viton) upon request.

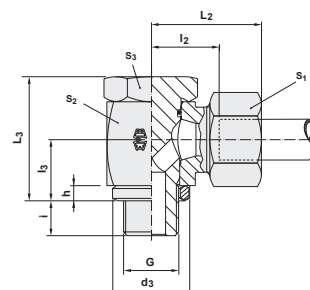

description	pipe OD	PB series	S ₁	S ₂	S ₃	L ₂	l ₂	l ₃	L ₃	d ₃	i	h	G	MA* Nm	kg / 100 pcs
DS-SBE 6-ML	6	L 500	14	17	17	27	12.0	10.5	24.0	14	8	2.5	M 10x1	25	6.5
DS-SBE 8-ML	8	L 500	17	22	19	29	14.5	14.0	30.0	17	12	3.0	M 12x1.5	50	11.4
DS-SBE 10-ML	10	L 500	19	22	19	30	15.5	14.0	30.0	19	12	3.0	M 14x1.5	60	12.5
DS-SBE 12-ML	12	L 400	22	27	24	33	18.0	16.5	36.0	21	12	3.0	M 16x1.5	90	20.3
DS-SBE 15-ML	15	L 400	27	30	27	36	20.5	18.5	39.5	23	12	3.0	M 18x1.5	110	28.8
DS-SBE 18-ML	18	L 400	32	32	30	37	21.0	21.5	45.0	27	14	4.5	M 22x1.5	150	38.8
DS-SBE 22-ML	22	L 250	36	41	36	44	27.5	24.0	53.0	31	16	3.5	M 26x1.5	350	65.8
DS-SBE 28-ML	28	L 250	41	50	46	49	32.0	30.5	66.0	39	18	3.5	M 33x2	400	110.3
DS-SBE 35-ML	35	L 250	50	60	55	58	36.0	35.5	76.0	49	20	3.5	M 42x2	600	166.3
DS-SBE 42-ML	42	L 250	60	70	60	63	40.5	40.5	87.0	55	22	3.5	M 48x2	800	249.9
DS-SBE 6-MS	6	S 500	17	22	19	31	16.5	14.0	30.0	17	12	3.0	M 12x1.5	50	12.2
DS-SBE 8-MS	8	S 500	19	22	19	31	16.5	14.0	30.0	19	12	3.0	M 14x1.5	60	13.2
DS-SBE 10-MS	10	S 500	22	27	24	35	18.5	16.5	36.0	21	12	3.0	M 16x1.5	90	21.7
DS-SBE 12-MS	12	S 500	24	30	27	36	20.0	18.5	39.5	23	12	3.0	M 18x1.5	110	28.0
DS-SBE 14-MS	14	S 500	27	32	30	40	22.5	20.0	48.5	25	14	3.0	M 20x1.5	130	37.4
DS-SBE 16-MS	16	S 500	30	32	30	40	22.0	21.5	45.0	27	14	4.5	M 22x1.5	150	39.4
DS-SBE 20-MS	20	S 400	36	41	36	48	26.5	24.0	53.0	32	16	3.5	M 27x2	350	68.8
DS-SBE 25-MS	25	S 400	46	50	46	56	31.5	30.5	66.0	39	18	3.5	M 33x2	400	126.0
DS-SBE 30-MS	30	S 400	50	60	55	64	37.0	35.5	76.0	49	20	3.5	M 42x2	600	176.3
DS-SBE 38-MS	38	S 400	60	70	60	72	41.5	40.5	87.0	55	22	3.5	M 48x2	800	296.9

L₂ = approximate length with nut tightened

* Recommended tightening torques for stud threads G, with mating material steel

Please see "Engineering and technical data - Selecting the correct tube fitting" for more information on pressure.

COUPLINGS

BANJO COUPLING

SBE BANJO COUPLING HIGH PRESSURE

THE WORLD OF TUBE FITTINGS

SBE BANJO COUPLING HIGH PRESSURE METRIC EDE

Metric parallel.

Sealing ring EDE (vulcanised NBR) for "narrow"
DIN 3852/d4 bore.

O-ring NBR (e.g. Perbunan), FPM (e.g. Viton) upon request.

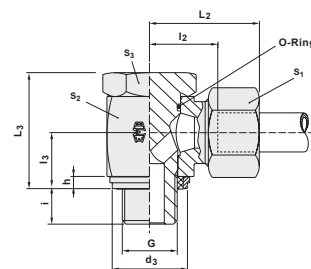

description	pipe OD	PB series	S ₁	S ₂	S ₃	L ₂	l ₂	l ₃	L ₃	d ₃	i	h	d ₉	G	MA* Nm	kg / 100 pcs
DS-SBE 6-ML/EDE	6	L 500	14	17	17	27	12.0	10.5	24.0	14.9	8	2.5	8	M 10x1	25	6.6
DS-SBE 8-ML/EDE	8	L 500	17	22	19	29	14.5	14.0	30.0	16.9	12	3.0	12	M 12x1.5	50	11.6
DS-SBE 10-ML/EDE	10	L 500	19	22	19	30	15.5	14.0	30.0	18.9	12	3.0	12	M 14x1.5	60	12.7
DS-SBE 12-ML/EDE	12	L 400	22	27	24	33	18.0	16.5	36.0	21.9	12	3.0	12	M 16x1.5	90	20.7
DS-SBE 15-ML/EDE	15	L 400	27	30	27	36	20.5	18.5	39.5	23.9	12	3.0	12	M 18x1.5	110	28.8
DS-SBE 18-ML/EDE	18	L 400	32	32	30	37	21.0	21.5	45.0	26.9	14	4.5	14	M 22x1.5	150	39.3
DS-SBE 22-ML/EDE	22	L 250	36	41	36	44	27.5	24.0	53.0	31.9	16	3.5	16	M 26x1.5	350	67.0
DS-SBE 28-ML/EDE	28	L 250	41	50	46	49	32.0	30.5	66.0	39.9	18	3.5	18	M 33x2	400	111.1
DS-SBE 35-ML/EDE	35	L 250	50	60	55	58	36.0	35.5	76.0	49.9	20	3.5	20	M 42x2	600	167.7
DS-SBE 42-ML/EDE	42	L 250	60	70	60	63	40.5	40.5	87.0	55.9	22	3.5	22	M 48x2	800	251.7
DS-SBE 6-MS/EDE	6	S 500	17	22	19	31	16.5	14.0	30.0	16.9	12	3.0	12	M 12x1.5	50	12.5
DS-SBE 8-MS/EDE	8	S 500	19	22	19	31	16.5	14.0	30.0	18.9	12	3.0	12	M 14x1.5	60	13.3
DS-SBE 10-MS/EDE	10	S 500	22	27	24	35	18.5	16.5	36.0	21.9	12	3.0	12	M 16x1.5	90	22.0
DS-SBE 12-MS/EDE	12	S 500	24	30	27	36	20.0	18.5	39.5	23.9	12	3.0	12	M 18x1.5	110	28.3
DS-SBE 16-MS/EDE	16	S 500	30	32	30	40	22.0	21.5	45.0	26.9	14	4.5	14	M 22x1.5	150	39.8
DS-SBE 20-MS/EDE	20	S 400	36	41	36	48	26.5	24.0	53.0	32.9	16	3.5	16	M 27x2	350	69.9
DS-SBE 25-MS/EDE	25	S 400	46	50	46	56	31.5	39.0	66.0	39.9	18	3.5	18	M 33x2	400	126.8
DS-SBE 30-MS/EDE	30	S 400	50	60	55	64	37.0	49.0	76.0	49.9	20	3.5	20	M 42x2	600	177.6
DS-SBE 38-MS/EDE	38	S 400	60	70	60	72	41.5	55.0	87.0	55.9	22	3.5	22	M 48x2	800	298.7

L₂ = approximate length with nut tightened

* Recommended tightening torques for stud threads G, with mating material steel

Please see "Engineering and technical data - Selecting the correct tube fitting" for more information on pressure.

COUPLINGS

BANJO COUPLING

SBE BANJO COUPLING HIGH PRESSURE

SBE BANJO COUPLING HIGH PRESSURE METRIC KDE

Metric parallel.

Metal joint ring KDE.

O-ring NBR (e.g. Perbunan), FPM (e.g. Viton) upon request.

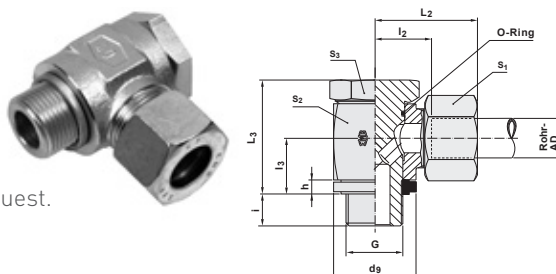

description	pipe OD	PB series	S ₁	S ₂	S ₃	L ₂	l ₂	l ₃	L ₃	d ₃	h	d ₉	G	MA* Nm	kg / 100 pcs
DS-SBE 6-ML/KDE	6	L 500	14	17	17	27	12.0	10.5	24.0	17	2.5	8	M 10x1	25	6.6
DS-SBE 8-ML/KDE	8	L 500	17	22	19	29	14.5	14.0	30.0	22	3.0	12	M 12x1.5	50	11.6
DS-SBE 10-ML/KDE	10	L 500	19	22	19	30	15.5	14.0	30.0	23	3.0	12	M 14x1.5	60	12.7
DS-SBE 12-ML/KDE	12	L 400	22	27	24	33	18.0	16.5	36.0	27	3.0	12	M 16x1.5	90	20.7
DS-SBE 15-ML/KDE	15	L 400	27	30	27	36	20.5	18.5	39.5	29	3.0	12	M 18x1.5	110	28.8
DS-SBE 18-ML/KDE	18	L 400	32	32	30	37	21.0	21.5	45.0	32	4.5	14	M 22x1.5	150	39.3
DS-SBE 22-ML/KDE	22	L 250	36	41	36	44	27.5	24.0	53.0	41	3.5	16	M 26x1.5	350	67.0
DS-SBE 28-ML/KDE	28	L 250	41	50	46	49	32.0	30.5	66.0	46	3.5	18	M 33x2	400	111.1
DS-SBE 35-ML/KDE	35	L 250	50	60	55	58	36.0	35.5	76.0	57	3.5	20	M 42x2	600	167.7
DS-SBE 42-ML/KDE	42	L 250	60	70	60	63	40.5	40.5	87.0	64	3.5	22	M 48x2	800	251.7
DS-SBE 6-MS/KDE	6	S 500	17	22	19	31	16.5	14.0	30.0	22	3.0	12	M 12x1.5	50	12.5
DS-SBE 8-MS/KDE	8	S 500	19	22	19	31	16.5	14.0	30.0	23	3.0	12	M 14x1.5	60	13.3
DS-SBE 10-MS/KDE	10	S 500	22	27	24	35	18.5	16.5	36.0	27	3.0	12	M 16x1.5	90	22.0
DS-SBE 12-MS/KDE	12	S 500	24	30	27	36	20.0	18.5	39.5	29	3.0	12	M 18x1.5	110	28.3
DS-SBE 16-MS/KDE	16	S 500	30	32	30	40	22.0	21.5	45.0	32	4.5	14	M 22x1.5	150	39.8
DS-SBE 20-MS/KDE	20	S 400	36	41	36	48	26.5	24.0	53.0	41	3.5	16	M 27x2	350	69.9
DS-SBE 25-MS/KDE	25	S 400	46	50	46	56	31.5	30.5	66.0	46	3.5	18	M 33x2	400	126.8
DS-SBE 30-MS/KDE	30	S 400	50	60	55	64	37.0	35.5	76.0	57	3.5	20	M 42x2	600	177.6
DS-SBE 38-MS/KDE	38	S 400	60	70	60	72	41.5	40.5	87.0	64	3.5	22	M 48x2	800	298.7

L₂ = approximate length with nut tightened

* Recommended tightening torques for stud threads G, with mating material steel

Please see "Engineering and technical data - Selecting the correct tube fitting" for more information on pressure.

COUPLINGS

BANJO COUPLING

SGE T SWIVELING SCREW FITTING HIGH PRESSURE

THE WORLD OF TUBE FITTINGS

SGE T SWIVELING SCREW FITTING HIGH PRESSURE BSP DKA

BSP parallel.

Edge sealing ring DKA.

O-ring NBR (e.g. Perbunan), FPM (e.g. Viton) upon request.

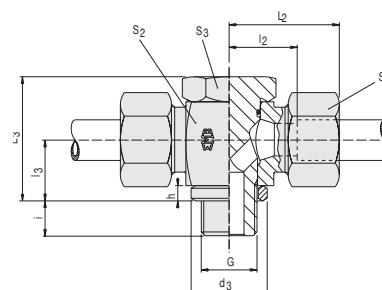

description	pipe OD	PB series	S ₁	S ₂	S ₃	L ₂	l ₂	l ₃	L ₃	d ₃	i	h	d ₉	G	MA* Nm	kg / 100 pcs
DS-SGE 6-RL	6	L 500	14	17	17	27	12.0	10.5	24	14	8	2.5	14.9	G 1/8"A	20	8.0
DS-SGE 8-RL	8	L 500	17	22	19	29	14.5	14.0	30	18	12	3.0	18.9	G 1/4"A	50	14.1
DS-SGE 10-RL	10	L 500	19	22	19	30	15.5	14.0	30	18	12	3.0	18.9	G 1/4"A	50	15.0
DS-SGE 12-RL	12	L 400	22	27	24	33	18.0	16.5	36	22	12	3.0	21.9	G 3/8"A	75	24.1
DS-SGE 15-RL	15	L 400	27	32	30	37	21.5	21.5	45	26	14	4.5	26.9	G 1/2"A	130	40.9
DS-SGE 18-RL	18	L 400	32	32	30	37	21.0	21.5	45	26	14	4.5	26.9	G 1/2"A	130	45.8
DS-SGE 22-RL	22	L 250	36	41	36	44	27.5	24.0	53	32	16	3.5	32.9	G 3/4"A	250	75.9
DS-SGE 28-RL	28	L 250	41	50	46	49	32.0	30.5	66	39	18	3.5	39.9	G 1" A	350	125.4
DS-SGE 35-RL	35	L 250	50	60	55	58	36.0	35.5	76	49	20	3.5	49.9	G 1 1/4"A	600	206.1
DS-SGE 42-RL	42	L 250	60	70	60	63	40.5	40.5	87	55	22	3.5	55.9	G 1 1/2"A	800	299.0
DS-SGE 6-RS	6	S 500	17	22	19	31	16.5	14.0	30	18	12	3.0	18.9	G 1/4"A	50	15.2
DS-SGE 8-RS	8	S 500	19	22	19	31	16.5	14.0	30	18	12	3.0	18.9	G 1/4"A	50	16.4
DS-SGE 10-RS	10	S 500	22	27	24	35	18.5	16.5	36	22	12	3.0	21.9	G 3/8"A	75	26.4
DS-SGE 12-RS	12	S 500	24	27	24	35	18.5	16.5	36	22	12	3.0	21.9	G 3/8"A	75	27.8
DS-SGE 14-RS	14	S 500	27	32	30	40	22.5	21.5	45	26	14	4.5	26.9	G 1/2"A	130	[37.5]
DS-SGE 16-RS	16	S 500	30	32	30	40	22.0	21.5	45	26	14	4.5	26.9	G 1/2"A	130	49.0
DS-SGE 20-RS	20	S 400	36	41	36	48	26.5	24.0	53	32	16	3.5	32.9	G 3/4"A	250	84.2
DS-SGE 25-RS	25	S 400	46	50	46	56	31.5	30.5	66	39	18	3.5	39.9	G 1" A	350	155.0
DS-SGE 30-RS	30	S 400	50	60	55	64	37.0	35.5	76	49	20	3.5	49.9	G 1 1/4"A	600	230.0
DS-SGE 38-RS	38	S 400	60	70	60	72	41.5	40.5	87	55	22	3.5	55.9	G 1 1/2"A	800	337.2

L₂ = approximate length with nut tightened

* Recommended tightening torques for stud threads G, with mating material steel

Please see "Engineering and technical data - Selecting the correct tube fitting" for more information on pressure.

COUPLINGS

BANJO COUPLING

SGE T SWIVELING SCREW FITTING HIGH PRESSURE

SGE T SWIVELING SCREW FITTING HIGH PRESSURE BSP EDE

BSP parallel.

Sealing ring EDE.

O-ring NBR (e.g. Perbunan), FPM (e.g. Viton) upon request.

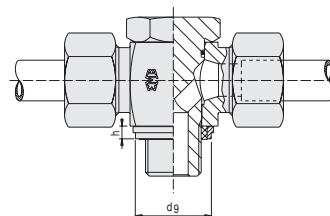

description	pipe OD	PB series	S ₁	S ₂	S ₃	L ₂	l ₂	l ₃	L ₃	d ₃	i	h	d ₉	G	MA* Nm	kg / 100 pcs
DS-SGE 6-RL/EDE	6	L 500	14	17	17	27	12.0	10.5	24	14	8	2.5	14.9	G 1/8"A	20	8.1
DS-SGE 8-RL/EDE	8	L 500	17	22	19	29	14.5	14.0	30	18	12	3.0	18.9	G 1/4"A	50	14.2
DS-SGE 10-RL/EDE	10	L 500	19	22	19	30	15.5	14.0	30	18	12	3.0	18.9	G 1/4"A	50	15.2
DS-SGE 12-RL/EDE	12	L 400	22	27	24	33	18.0	16.5	36	22	12	3.0	21.9	G 3/8"A	75	24.3
DS-SGE 15-RL/EDE	15	L 400	27	32	30	37	21.5	21.5	45	26	14	4.5	26.9	G 1/2"A	130	41.5
DS-SGE 18-RL/EDE	18	L 400	32	32	30	37	21.0	21.5	45	26	14	4.5	26.9	G 1/2"A	130	46.4
DS-SGE 22-RL/EDE	22	L 250	36	41	36	44	27.5	24.0	53	32	16	3.5	32.9	G 3/4"A	250	77.0
DS-SGE 28-RL/EDE	28	L 250	41	50	46	49	32.0	30.5	66	39	18	3.5	39.9	G 1" A	350	126.2
DS-SGE 35-RL/EDE	35	L 250	50	60	55	58	36.0	35.5	76	49	20	3.5	49.9	G 1 1/4"A	600	207.4
DS-SGE 42-RL/EDE	42	L 250	60	70	60	63	40.5	40.5	87	55	22	3.5	55.9	G 1 1/2"A	800	300.8
DS-SGE 6-RS/EDE	6	S 500	17	22	19	31	16.5	14.0	30	18	12	3.0	18.9	G 1/4"A	50	15.3
DS-SGE 8-RS/EDE	8	S 500	19	22	19	31	16.5	14.0	30	18	12	3.0	18.9	G 1/4"A	50	16.6
DS-SGE 10-RS/EDE	10	S 500	22	27	24	35	18.5	16.5	36	22	12	3.0	21.9	G 3/8"A	75	26.7
DS-SGE 12-RS/EDE	12	S 500	24	27	24	35	18.5	16.5	36	22	12	3.0	21.9	G 3/8"A	75	28.1
DS-SGE 14-RS/EDE	14	S 500	27	32	30	40	22.5	21.5	45	26	14	4.5	26.9	G 1/2"A	130	(38.0)
DS-SGE 16-RS/EDE	16	S 500	30	32	30	40	22.0	21.5	45	26	14	4.5	26.9	G 1/2"A	130	49.6
DS-SGE 20-RS/EDE	20	S 400	36	41	36	48	26.5	24.0	53	32	16	3.5	32.9	G 3/4"A	250	85.2
DS-SGE 25-RS/EDE	25	S 400	46	50	46	56	31.5	30.5	66	39	18	3.5	39.9	G 1" A	350	155.9
DS-SGE 30-RS/EDE	30	S 400	50	60	55	64	37.0	35.5	76	49	20	3.5	49.9	G 1 1/4"A	600	231.4
DS-SGE 38-RS/EDE	38	S 400	60	70	60	72	41.5	40.5	87	55	22	3.5	55.9	G 1 1/2"A	800	339.0

L₂ = approximate length with nut tightened

* Recommended tightening torques for stud threads G, with mating material steel

Please see "Engineering and technical data - Selecting the correct tube fitting" for more information on pressure.

COUPLINGS

BANJO COUPLING

SGE T SWIVELING SCREW FITTING HIGH PRESSURE

THE WORLD OF TUBE FITTINGS

SGE T SWIVELING SCREW FITTING HIGH PRESSURE METRIC DKA

Metric parallel.

Edge sealing ring DKA.

O-ring NBR (e.g. Perbunan), FPM (e.g. Viton) upon request.

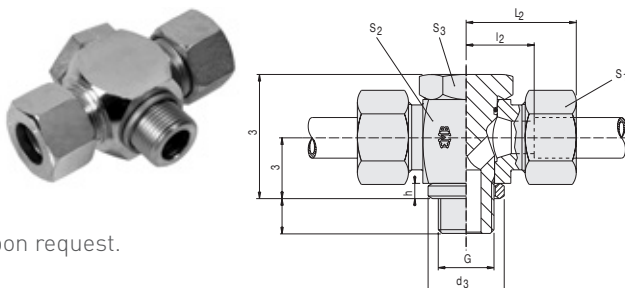

description	pipe OD	PB series	S ₁	S ₂	S ₃	L ₂	l ₂	l ₃	L ₃	d ₃	i	h	d ₉	G	MA* Nm	kg / 100 pcs
DS-SGE 6-ML	6	L 500	14	17	17	27	12.0	10.5	24.0	14	8	2.5	14.9	M 10x1	25	8.1
DS-SGE 8-ML	8	L 500	17	22	19	29	14.5	14.0	30.0	17	12	3.0	16.9	M 12x1.5	50	13.8
DS-SGE 10-ML	10	L 500	19	22	19	30	15.5	14.0	30.0	19	12	3.0	18.9	M 14x1.5	60	15.3
DS-SGE 12-ML	12	L 400	22	27	24	33	18.0	16.5	36.0	21	12	3.0	21.9	M 16x1.5	90	23.7
DS-SGE 15-ML	15	L 400	27	30	27	36	20.5	18.5	39.5	23	12	3.0	23.9	M 18x1.5	110	34.3
DS-SGE 18-ML	18	L 400	32	32	30	37	21.0	21.5	45.0	27	14	4.5	26.9	M 22x1.5	150	46.3
DS-SGE 22-ML	22	L 250	36	41	36	44	27.5	24.0	53.0	31	16	3.5	31.9	M 26x1.5	350	76.0
DS-SGE 28-ML	28	L 250	41	50	46	49	32.0	30.5	66.0	39	18	3.5	39.9	M 33x2	400	122.9
DS-SGE 35-ML	35	L 250	50	60	55	58	36.0	35.5	76.0	49	20	3.5	49.9	M 42x2	600	206.0
DS-SGE 42-ML	42	L 250	60	70	60	63	40.5	40.5	87.0	55	22	3.5	55.9	M 48x2	800	303.0
DS-SGE 6-MS	6	S 500	17	22	19	31	16.5	14.0	30.0	17	12	3.0	16.9	M 12x1.5	50	14.8
DS-SGE 8-MS	8	S 500	19	22	19	31	16.5	14.0	30.0	19	12	3.0	18.9	M 14x1.5	60	16.6
DS-SGE 10-MS	10	S 500	22	27	24	35	18.5	16.5	36.0	21	12	3.0	21.9	M 16x1.5	90	26.2
DS-SGE 12-MS	12	S 500	24	30	27	36	20.0	18.5	39.5	23	12	3.0	23.9	M 18x1.5	110	33.1
DS-SGE 14-MS	14	S 500	27	32	30	40	22.5	20.0	43.5	25	14	3.0	-	M 20x1.5	130	(37.4)
DS-SGE 16-MS	16	S 500	30	32	30	40	22.0	21.5	45.0	27	14	4.5	26.9	M 22x1.5	150	48.7
DS-SGE 20-MS	20	S 400	36	41	36	48	26.5	24.0	53.0	32	16	3.5	32.9	M 27x2	350	83.7
DS-SGE 25-MS	25	S 400	46	50	46	56	31.5	30.5	66.0	39	18	3.5	39.9	M 33x2	400	152.6
DS-SGE 30-MS	30	S 400	50	60	55	64	37.0	35.5	76.0	49	20	3.5	49.9	M 42x2	600	229.9
DS-SGE 38-MS	38	S 400	60	70	60	72	41.5	40.5	87.0	55	22	3.5	55.9	M 48x2	800	341.2

L₂ = approximate length with nut tightened

* Recommended tightening torques for stud threads G, with mating material steel

Please see "Engineering and technical data - Selecting the correct tube fitting" for more information on pressure.

COUPLINGS

BANJO COUPLING

SGE T SWIVELING SCREW FITTING HIGH PRESSURE

SGE T SWIVELING SCREW FITTING HIGH PRESSURE METRIC EDE

Metric parallel.

Sealing ring EDE.

O-ring NBR (e.g. Perbunan), FPM (e.g. Viton) upon request.

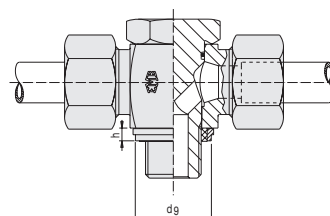

description	pipe OD	PB series	S ₁	S ₂	S ₃	L ₂	l ₂	l ₃	L ₃	d ₃	i	h	d ₉	G	MA* Nm	kg / 100 pcs
DS-SGE 6-ML/EDE	6	L 500	14	17	17	27	12.0	10.5	24.0	14	8	2.5	14.9	M 10x1	25	8.1
DS-SGE 8-ML/EDE	8	L 500	17	22	19	29	14.5	14.0	30.0	17	12	3.0	16.9	M 12x1.5	50	14.0
DS-SGE 10-ML/EDE	10	L 500	19	22	19	30	15.5	14.0	30.0	19	12	3.0	18.9	M 14x1.5	60	15.4
DS-SGE 12-ML/EDE	12	L 400	22	27	24	33	18.0	16.5	36.0	21	12	3.0	21.9	M 16x1.5	90	24.0
DS-SGE 15-ML/EDE	15	L 400	27	30	27	36	20.5	18.5	39.5	23	12	3.0	23.9	M 18x1.5	110	34.7
DS-SGE 18-ML/EDE	18	L 400	32	32	30	37	21.0	21.5	45.0	27	14	4.5	26.9	M 22x1.5	150	46.8
DS-SGE 22-ML/EDE	22	L 250	36	41	36	44	27.5	24.0	53.0	31	16	3.5	31.9	M 26x1.5	350	77.2
DS-SGE 28-ML/EDE	28	L 250	41	50	46	49	32.0	30.5	66.0	39	18	3.5	39.9	M 33x2	400	123.8
DS-SGE 35-ML/EDE	35	L 250	50	60	55	58	36.0	35.5	76.0	49	20	3.5	49.9	M 42x2	600	207.4
DS-SGE 42-ML/EDE	42	L 250	60	70	60	63	40.5	40.5	87.0	55	22	3.5	55.9	M 48x2	800	304.8
DS-SGE 6-MS/EDE	6	S 500	17	22	19	31	16.5	14.0	30.0	17	12	3.0	16.9	M 12x1.5	50	15.1
DS-SGE 8-MS/EDE	8	S 500	19	22	19	31	16.5	14.0	30.0	19	12	3.0	18.9	M 14x1.5	60	16.8
DS-SGE 10-MS/EDE	10	S 500	22	27	24	35	18.5	16.5	36.0	21	12	3.0	21.9	M 16x1.5	90	26.5
DS-SGE 12-MS/EDE	12	S 500	24	30	27	36	20.0	18.5	39.5	23	12	3.0	23.9	M 18x1.5	110	33.5
DS-SGE 16-MS/EDE	16	S 500	30	32	30	40	22.0	21.5	45.0	27	14	4.5	26.9	M 22x1.5	150	49.2
DS-SGE 20-MS/EDE	20	S 400	36	41	36	48	26.5	24.0	53.0	32	16	3.5	32.9	M 27x2	350	84.8
DS-SGE 25-MS/EDE	25	S 400	46	50	46	56	31.5	30.5	66.0	39	18	3.5	39.9	M 33x2	400	153.5
DS-SGE 30-MS/EDE	30	S 400	50	60	55	64	37.0	35.5	76.0	49	20	3.5	49.9	M 42x2	600	231.3
DS-SGE 38-MS/EDE	38	S 400	60	70	60	72	41.5	40.5	87.0	55	22	3.5	55.9	M 48x2	800	343.0

L₂ = approximate length with nut tightened

* Recommended tightening torques for stud threads G, with mating material steel

Please see "Engineering and technical data - Selecting the correct tube fitting" for more information on pressure.

COUPLINGS

ADJUSTABLE COUPLING

THE WORLD OF TUBE FITTINGS

VB ADJUSTABLE ELBOW

Without straight screw- in screw-joint.

These parts are ready mounted not pre-assembled.

After screwing on by hand, tighten with a spanner until tight, and then apply final 30° turn.

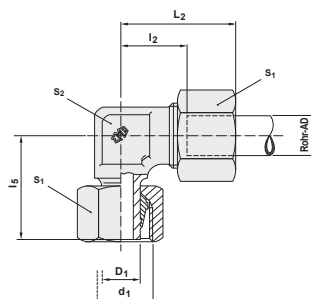

description	pipe OD	PN series	L ₂	l ₂	l ₅	D ₁	d ₁	S ₁	S ₂	kg / 100 pcs
DS-VB 6-L	6	L 500 (2200)	27	12.0	26.0	6	M 12x1.5	14	12	3.6
DS-VB 8-L	8	L 500 (2200)	29	14.0	27.5	8	M 14x1.5	17	12	5.0
DS-VB 10-L	10	L 500 (2200)	30	15.0	29.0	10	M 16x1.5	19	14	6.8
DS-VB 12-L	12	L 400 (1700)	32	17.0	29.5	12	M 18x1.5	22	17	9.0
DS-VB 15-L	15	L 400 (1700)	36	21.0	32.5	15	M 22x1.5	27	19	15.3
DS-VB 18-L	18	L 400 (1700)	40	23.5	35.5	18	M 26x1.5	32	24	22.6
DS-VB 22-L	22	L 250 (1100)	44	27.5	38.5	22	M 30x2	36	27	30.4
DS-VB 28-L	28	L 250 (1100)	47	30.5	41.5	28	M 36x2	41	36	42.5
DS-VB 35-L	35	L 250 (1100)	56	34.5	51.0	35	M 45x2	50	41	64.7
DS-VB 42-L	42	L 250 (1100)	63	40.0	56.0	42	M 52x2	60	50	99.7
DS-VB 6-S	6	S 800 (3400)	31	16.0	27.0	6	M 14x1.5	17	12	5.7
DS-VB 8-S	8	S 800 (3400)	32	17.0	27.5	8	M 16x1.5	19	14	7.0
DS-VB 10-S	10	S 800 (3400)	34	17.5	30.0	10	M 18x1.5	22	17	11.1
DS-VB 12-S	12	S 630 (2700)	38	21.5	31.0	12	M 20x1.5	24	17	13.8
DS-VB 14-S	14	S 630 (2700)	40	22.0	35.0	14	M 22x1.5	27	19	18.9
DS-VB 16-S	16	S 630 (2700)	43	24.5	36.5	16	M 24x1.5	30	24	23.8
DS-VB 20-S	20	S 400 (1700)	48	26.5	44.5	20	M 30x2	36	27	36.2
DS-VB 25-S	25	S 400 (1700)	54	30.0	50.0	25	M 36x2	46	36	72.1
DS-VB 30-S	30	S 400 (1700)	62	35.5	55.0	30	M 42x2	50	41	96.4
DS-VB 38-S	38	S 400 (1700)	72	41.0	63.0	38	M 52x2	60	50	138.4

L₂ = approximate length with nut tightened

Please see "Engineering and technical data - Selecting the correct tube fitting" for more information on pressure.

COUPLINGS

ADJUSTABLE COUPLING

VC ADJUSTABLE BRANCH TEE

Without straight screw- in screw-joint.

These parts are ready mounted
not pre-assembled.

After screwing on by hand, tighten with
a spanner until tight, and then apply
final 30° turn.

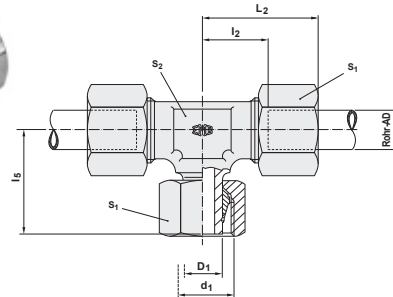

description	pipe OD	PN series	L ₂	l ₂	l ₅	D ₁	d ₁	S ₁	S ₂	kg / 100 pcs
DS-VC 6-L	6	L 500 (2200)	27	12.0	26.0	6	M 12x1.5	14	12	5.3
DS-VC 8-L	8	L 500 (2200)	29	14.0	27.5	8	M 14x1.5	17	12	7.4
DS-VC 10-L	10	L 500 (2200)	30	15.0	29.0	10	M 16x1.5	19	14	10.3
DS-VC 12-L	12	L 400 (1700)	32	17.0	29.5	12	M 18x1.5	22	17	12.9
DS-VC 15-L	15	L 400 (1700)	36	21.0	32.5	15	M 22x1.5	27	19	21.8
DS-VC 18-L	18	L 400 (1700)	40	23.5	35.5	18	M 26x1.5	32	24	32.4
DS-VC 22-L	22	L 250 (1100)	44	27.5	38.5	22	M 30x2	36	27	43.3
DS-VC 28-L	28	L 250 (1100)	47	30.5	41.5	28	M 36x2	41	36	57.9
DS-VC 35-L	35	L 250 (1100)	56	34.5	51.0	35	M 45x2	50	41	90.1
DS-VC 42-L	42	L 250 (1100)	63	40.0	56.0	42	M 52x2	60	50	135.3
DS-VC 6-S	6	S 800 (3400)	31	16.0	27.0	6	M 14x1.5	17	12	8.5
DS-VC 8-S	8	S 800 (3400)	32	17.0	27.5	8	M 16x1.5	19	14	10.7
DS-VC 10-S	10	S 800 (3400)	34	17.5	30.0	10	M 18x1.5	22	17	16.5
DS-VC 12-S	12	S 630 (2700)	38	21.5	31.0	12	M 20x1.5	24	17	20.4
DS-VC 14-S	14	S 630 (2700)	40	22.0	35.0	14	M 22x1.5	27	19	27.5
DS-VC 16-S	16	S 630 (2700)	43	24.5	36.5	16	M 24x1.5	30	24	35.6
DS-VC 20-S	20	S 400 (1700)	48	26.5	44.5	20	M 30x2	36	27	53.6
DS-VC 25-S	25	S 400 (1700)	54	30.0	50.0	25	M 36x2	46	36	104.2
DS-VC 30-S	30	S 400 (1700)	62	35.5	55.0	30	M 42x2	50	41	133.3
DS-VC 38-S	38	S 400 (1700)	72	41.0	63.0	38	M 52x2	60	50	204.7

L₂ = approximate length with nut tightened

Please see "Engineering and technical data - Selecting the correct tube fitting" for more information on pressure.

COUPLINGS ADJUSTABLE COUPLING

THE WORLD OF TUBE FITTINGS

VD ADJUSTABLE BARREL TEE

Without straight screw- in screw-joint.

These parts are ready mounted
not pre-assembled.

After screwing on by hand, tighten with
a spanner until tight, and then apply final 30° turn.

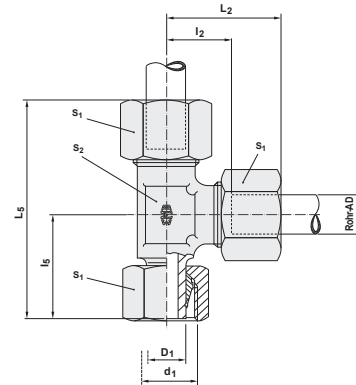

description	pipe OD	PN series	L ₂	l ₂	l ₅	L ₅	D ₁	d ₁	S ₁	S ₂	kg / 100 pcs
DS-VD 6-L	6	L 500 (2200)	27	12.0	26.0	53	6	M 12x1.5	14	12	5.2
DS-VD 8-L	8	L 500 (2200)	29	14.0	27.5	56	8	M 14x1.5	17	12	7.8
DS-VD 10-L	10	L 500 (2200)	30	15.0	29.0	59	10	M 16x1.5	19	14	10.5
DS-VD 12-L	12	L 400 (1700)	32	17.0	29.5	62	12	M 18x1.5	22	17	12.6
DS-VD 15-L	15	L 400 (1700)	36	21.0	32.5	70	15	M 22x1.5	27	19	21.8
DS-VD 18-L	18	L 400 (1700)	40	23.5	35.5	76	18	M 26x1.5	32	24	32.9
DS-VD 22-L	22	L 250 (1100)	44	27.5	38.5	83	22	M 30x2	36	27	43.3
DS-VD 28-L	28	L 250 (1100)	47	30.5	41.5	91	28	M 36x2	41	36	55.8
DS-VD 35-L	35	L 250 (1100)	56	34.5	51.0	111	35	M 45x2	50	41	89.1
DS-VD 42-L	42	L 250 (1100)	63	40.0	56.0	123	42	M 52x2	60	50	132.8
DS-VD 6-S	6	S 800 (3400)	31	16.0	27.0	58	6	M 14x1.5	17	12	8.7
DS-VD 8-S	8	S 800 (3400)	32	17.0	27.5	61	8	M 16x1.5	19	14	10.7
DS-VD 10-S	10	S 800 (3400)	34	17.5	30.0	66	10	M 18x1.5	22	17	16.6
DS-VD 12-S	12	S 630 (2700)	38	21.5	31.0	71	12	M 20x1.5	24	17	20.4
DS-VD 14-S	14	S 630 (2700)	40	22.0	35.0	76	14	M 22x1.5	27	19	27.1
DS-VD 16-S	16	S 630 (2700)	43	24.5	36.5	80	16	M 24x1.5	30	24	33.7
DS-VD 20-S	20	S 400 (1700)	48	26.5	44.5	93	20	M 30x2	36	27	54.2
DS-VD 25-S	25	S 400 (1700)	54	30.0	50.0	105	25	M 36x2	46	36	102.6
DS-VD 30-S	30	S 400 (1700)	62	35.5	55.0	119	30	M 42x2	50	41	132.5
DS-VD 38-S	38	S 400 (1700)	72	41.0	63.0	139	38	M 52x2	60	50	195.0

L₂ = approximate length with nut tightened

Please see "Engineering and technical data - Selecting the correct tube fitting" for more information on pressure.

COUPLINGS

ADJUSTABLE COUPLING

VBDKO ADJUSTABLE MALE STUD ELBOW

With taper and O-ring according to DIN 3865.

O-ring NBR (e.g. Perbunan), FPM (e.g. Viton) upon request.

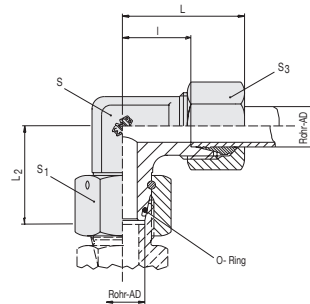

description	pipe OD	PN series	L ₂	L	L ₁	S	S ₁	S ₃	kg / 100 pcs	O-Ring
DS-VBDKO 6-L	6	L 500 (2200)	26.0	27	12.0	12	17	14	4.0	4x1.5
DS-VBDKO 8-L	8	L 500 (2200)	27.5	29	14.0	12	17	17	5.5	6x1.5
DS-VBDKO 10-L	10	L 500 (2200)	29.0	30	15.0	14	19	19	7.1	7.5x1.5
DS-VBDKO 12-L	12	L 400 (1700)	29.5	32	17.0	17	22	22	9.6	9x1.5
DS-VBDKO 15-L	15	L 400 (1700)	32.5	36	21.0	19	27	27	16.6	12x2
DS-VBDKO 18-L	18	L 400 (1700)	35.5	40	23.5	24	32	32	23.6	15x2
DS-VBDKO 22-L	22	L 250 (1100)	38.5	44	27.5	27	36	36	32.7	20x2
DS-VBDKO 28-L	28	L 250 (1100)	41.5	47	30.5	36	41	41	52.4	26x2
DS-VBDKO 35-L	35	L 250 (1100)	51.0	56	34.5	41	50	50	68.8	32x2.5
DS-VBDKO 42-L	42	L 250 (1100)	56.0	63	40.0	50	60	60	108.0	38x2.5
DS-VBDKO 6-S	6	S 800 (3400)	27.0	31	16.0	14	17	17	6.2	4x1.5
DS-VBDKO 8-S	8	S 800 (3400)	27.5	32	17.0	17	19	19	7.4	6x1.5
DS-VBDKO 10-S	10	S 800 (3400)	30.0	34	17.5	19	22	22	11.3	7.5x1.5
DS-VBDKO 12-S	12	S 630 (2700)	31.0	38	21.5	22	24	24	14.0	9x1.5
DS-VBDKO 14-S	14	S 630 (2700)	35.0	40	22.0	19	27	27	19.3	10x2
DS-VBDKO 16-S	16	S 630 (2700)	36.5	43	24.5	24	30	30	25.8	12x2
DS-VBDKO 20-S	20	S 400 (1700)	44.5	48	26.5	27	36	36	40.3	16.3x2.4
DS-VBDKO 25-S	25	S 400 (1700)	50.0	54	30.0	36	46	46	75.1	20.3x2.4
DS-VBDKO 30-S	30	S 400 (1700)	55.0	62	35.5	41	50	50	96.4	25.3x2.4
DS-VBDKO 38-S	38	S 400 (1700)	63.0	72	41.0	50	60	60	142.5	33.3x2.4

L = approximate length with nut tightened

Please see "Engineering and technical data - Selecting the correct tube fitting" for more information on pressure.

COUPLINGS ADJUSTABLE COUPLING

THE WORLD OF TUBE FITTINGS

BFDKO ADJUSTABLE 45° ELBOW

O-ring NBR (e.g. Perbunan), FPM (e.g. Viton)
upon request.

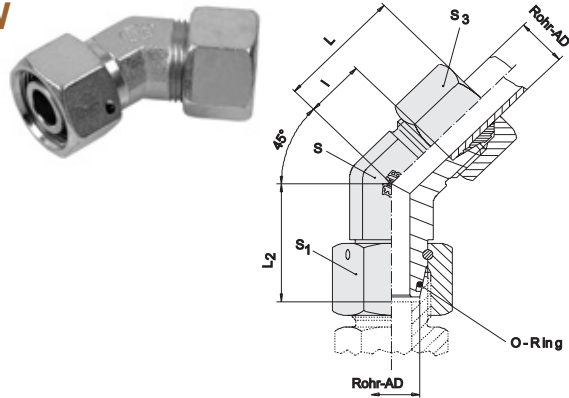

description	pipe OD	PN series	L ₂	L	I	S	S ₁	S ₃	kg / 100 pcs	O-Ring
DS-BFDKO 6-L	6	L 500	26.0	24	9	14	17	14	4.3	4.5x1.5
DS-BFDKO 8-L	8	L 500	27.5	27	12	14	17	17	5.7	6.5x1.5
DS-BFDKO 10-L	10	L 500	29.0	27	12	19	19	19	7.3	8x1.5
DS-BFDKO 12-L	12	L 400	29.5	28	14	19	22	22	10.0	10x1.5
DS-BFDKO 15-L	15	L 400	32.5	32	17	22	27	27	16.8	12x2
DS-BFDKO 18-L	18	L 400	35.5	33	17	27	32	32	24.1	15x2
DS-BFDKO 22-L	22	L 250	38.5	35	19	30	36	36	33.0	20x2
DS-BFDKO 28-L	28	L 250	41.5	40	23	36	41	41	49.3	26x2
DS-BFDKO 35-L	35	L 250	51.0	48	27	50	50	50	69.0	32x2.5
DS-BFDKO 42-L	42	L 250	56.0	49	26	50	60	60	108.1	38x2.5
DS-BFDKO 6-S	6	S 800	27.0	24	9	14	17	17	6.4	4.5x1.5
DS-BFDKO 8-S	8	S 800	27.5	27	12	19	19	19	8.4	6.5x1.5
DS-BFDKO 10-S	10	S 800	30.0	29	13	19	22	22	11.5	8x1.5
DS-BFDKO 12-S	12	S 630	31.0	33	17	19	24	24	14.2	10x1.5
DS-BFDKO 16-S	16	S 630	36.5	34	16	19	30	30	26.0	13x2
DS-BFDKO 20-S	20	S 400	44.5	38	16	27	36	36	40.6	16.3x2.4
DS-BFDKO 25-S	25	S 400	50.0	43	19	36	46	46	74.7	20.3x2.4
DS-BFDKO 30-S	30	S 400	55.0	50	24	50	50	50	95.7	25.3x2.4
DS-BFDKO 38-S	38	S 400	63.0	52	21	50	60	60	142.9	33.3x2.4

Please see "Engineering and technical data - Selecting the correct tube fitting" for more information on pressure.

COUPLINGS

ADJUSTABLE COUPLING

VCDKO ADJUSTABLE EQUAL TEE

With taper and O-ring according to DIN 3865.

O-ring NBR (e.g. Perbunan), FPM (e.g. Viton) upon request.

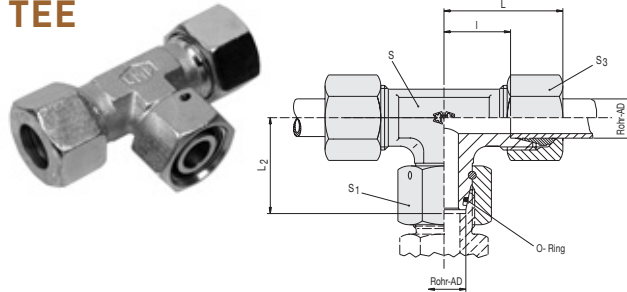

description	pipe OD	PN series	L ₂	L	I	S (A)	S (B)	S ₁	S ₃	kg / 100 pcs	O-Ring
DS-VCDKO 6-L	6	L 500 (2200)	26.0	27	12.0	12	12	17	14	5.8	4x1.5
DS-VCDKO 8-L	8	L 500 (2200)	27.5	29	14.0	14	12	17	17	7.9	6x1.5
DS-VCDKO 10-L	10	L 500 (2200)	29.0	30	15.0	17	14	19	19	10.1	7.5x1.5
DS-VCDKO 12-L	12	L 400 (1700)	29.5	32	17.0	19	17	22	22	13.5	9x1.5
DS-VCDKO 15-L	15	L 400 (1700)	32.5	36	21.0		19	27	27	23.3	12x2
DS-VCDKO 18-L	18	L 400 (1700)	35.5	40	23.5		24	32	32	33.2	15x2
DS-VCDKO 22-L	22	L 250 (1100)	38.5	44	27.5		27	36	36	44.6	20x2
DS-VCDKO 28-L	28	L 250 (1100)	41.5	47	30.5		36	41	41	70.2	26x2
DS-VCDKO 35-L	35	L 250 (1100)	51.0	56	34.5		41	50	50	96.1	32x2.5
DS-VCDKO 42-L	42	L 250 (1100)	56.0	63	40.0		50	60	60	146.1	38x2.5
DS-VCDKO 6-S	6	S 800 (3400)	27.0	31	16.0		14	17	17	8.7	4x1.5
DS-VCDKO 8-S	8	S 800 (3400)	27.5	32	17.0		17	19	19	11.8	6x1.5
DS-VCDKO 10-S	10	S 800 (3400)	30.0	34	17.5		19	22	22	16.3	7.5x1.5
DS-VCDKO 12-S	12	S 630 (2700)	31.0	38	21.5		22	24	24	20.6	9x1.5
DS-VCDKO 14-S	14	S 630 (2700)	35.0	40	22.0		19	27	27	28.1	10x2
DS-VCDKO 16-S	16	S 630 (2700)	36.5	43	24.5		24	30	30	37.3	12x2
DS-VCDKO 20-S	20	S 400 (1700)	44.5	48	26.5		27	36	36	56.8	16.3x2.4
DS-VCDKO 25-S	25	S 400 (1700)	50.0	54	30.0		36	46	46	107.9	20.3x2.4
DS-VCDKO 30-S	30	S 400 (1700)	55.0	62	35.5		41	50	50	136.3	25.3x2.4
DS-VCDKO 38-S	38	S 400 (1700)	63.0	72	41.0		50	60	60	203.6	33.3x2.4

L = approximate length with nut tightened

Pipe OD 6-42 = forging

Please see "Engineering and technical data - Selecting the correct tube fitting" for more information on pressure.

COUPLINGS ADJUSTABLE COUPLING

THE WORLD OF TUBE FITTINGS

VDDKO ADJUSTABLE MALE STUD TEE-STUD BARREL

With taper and O-ring according to DIN 3865.

O-ring NBR (e.g. Perbunan),
FPM (e.g. Viton) upon request.

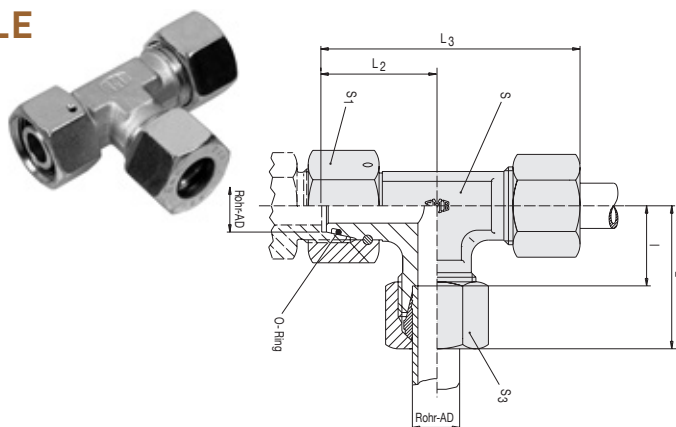

description	pipe OD	PN series	L ₂	L	I	S (A)	S (B)	S ₁	S ₃	L ₃	kg / 100 pcs	O-Ring
DS-VDDKO 6-L	6	L 500 (2200)	26.0	27	12.0	12	12	17	14	53	5.8	4x1.5
DS-VDDKO 8-L	8	L 500 (2200)	27.5	29	14.0	14	12	17	17	56	7.9	6x1.5
DS-VDDKO 10-L	10	L 500 (2200)	29.0	30	15.0	17	14	19	19	59	10.0	7.5x1.5
DS-VDDKO 12-L	12	L 400 (1700)	29.5	32	17.0	19	17	22	22	62	13.4	9x1.5
DS-VDDKO 15-L	15	L 400 (1700)	32.5	36	21.0		19	27	27	70	23.3	12x2
DS-VDDKO 18-L	18	L 400 (1700)	35.5	40	23.5		24	32	32	76	33.2	15x2
DS-VDDKO 22-L	22	L 250 (1100)	38.5	44	27.5		27	36	36	83	44.3	20x2
DS-VDDKO 28-L	28	L 250 (1100)	41.5	47	30.5		36	41	41	91	70.2	26x2
DS-VDDKO 35-L	35	L 250 (1100)	51.0	56	34.5		41	50	50	111	94.5	32x2.5
DS-VDDKO 42-L	42	L 250 (1100)	56.0	63	40.0		50	60	60	123	146.3	38x2.5
DS-VDDKO 6-S	6	S 800 (3400)	27.0	31	16.0		14	17	17	58	9.1	4x1.5
DS-VDDKO 8-S	8	S 800 (3400)	27.5	32	17.0		17	19	19	61	11.8	6x1.5
DS-VDDKO 10-S	10	S 800 (3400)	30.0	34	17.5		19	22	22	66	16.4	7.5x1.5
DS-VDDKO 12-S	12	S 630 (2700)	31.0	38	21.5		22	24	24	71	20.7	9x1.5
DS-VDDKO 14-S	14	S 630 (2700)	35.0	40	22.0		19	27	27	76	28.1	10x2
DS-VDDKO 16-S	16	S 630 (2700)	36.5	43	24.5		24	30	30	80	38.2	12x2
DS-VDDKO 20-S	20	S 400 (1700)	44.5	48	26.5		27	36	36	93	58.3	16.3x2.4
DS-VDDKO 25-S	25	S 400 (1700)	50.0	54	30.0		36	46	46	105	107.8	20.3x2.4
DS-VDDKO 30-S	30	S 400 (1700)	55.0	62	35.5		41	50	50	119	138.0	25.3x2.4
DS-VDDKO 38-S	38	S 400 (1700)	63.0	72	41.0		50	60	60	139	205.1	33.3x2.4

L+L₃ = approximate length with nut tightened

Pipe OD 6-42 = forging

Please see "Engineering and technical data - Selecting the correct tube fitting" for more information on pressure

COUPLINGS

STANDPIPE COUPLING

VA STUD STANDPIPE COUPLING

VA STUD STANDPIPE COUPLING BSP

These parts are ready mounted not pre-assembled.

After screwing on by hand, tighten with a spanner until tight, and then apply final 30° turn.

BSP parallel with stud.

Final assembled according to DIN 3955.

Captive seal NBR (e.g. Perbunan), FPM (e.g. Viton) upon request.

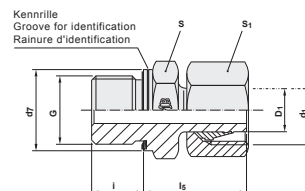

description	pipe OD	PN series	l_5	d_7	D_1	i	S_1	S	d_1	G	kg / 100 pcs
DS-VA 6-RL/WD	6	L 500 (2200)	24.5	14	6	8	14	14	M 12x1.5	G 1/8" A	2.5
DS-VA 8-RL/WD	8	L 500 (2200)	29.5	19	8	12	17	19	M 14x1.5	G 1/4" A	4.5
DS-VA 10-RL/WD	10	L 500 (2200)	27.5	19	10	12	19	19	M 16x1.5	G 1/4" A	4.7
DS-VA 12-RL/WD	12	L 400 (1700)	34.0	22	12	12	22	22	M 18x1.5	G 3/8" A	6.3
DS-VA 15-RL/WD	15	L 400 (1700)	32.0	27	15	14	27	27	M 22x1.5	G 1/2" A	11.5
DS-VA 18-RL/WD	18	L 400 (1700)	31.5	27	18	14	32	27	M 26x1.5	G 1/2" A	12.9
DS-VA 22-RL/WD	22	L 250 (1100)	32.5	32	22	16	36	32	M 30x2	G 3/4" A	17.6
DS-VA 28-RL/WD	28	L 250 (1100)	35.0	40	28	18	41	41	M 36x2	G 1" A	24.7
DS-VA 35-RL/WD	35	L 250 (1100)	42.5	50	35	20	50	50	M 45x2	G 1 1/4" A	40.7
DS-VA 42-RL/WD	42	L 250 (1100)	46.5	55	42	22	60	55	M 52x2	G 1 1/2" A	45.6
DS-VA 6-RS/WD	6	S 800 (3400)	27.0	19	6	12	17	19	M 14x1.5	G 1/4" A	5.0
DS-VA 8-RS/WD	8	S 800 (3400)	29.5	19	8	12	19	19	M 16x1.5	G 1/4" A	5.5
DS-VA 10-RS/WD	10	S 800 (3400)	32.0	22	10	12	22	22	M 18x1.5	G 3/8" A	8.2
DS-VA 12-RS/WD	12	S 630 (2700)	34.0	22	12	12	24	22	M 20x1.5	G 3/8" A	9.5
DS-VA 12-S/R 1/2"/WD	12	S 630 (2700)	33.5	27	12	14	24	27	M 20x1.5	G 1/2" A	11.8
DS-VA 14-RS/WD	14	S 630 (2700)	36.5	27	14	14	27	27	M 22x1.5	G 1/2" A	14.8
DS-VA 16-RS/WD	16	S 630 (2700)	37.0	27	16	14	30	27	M 24x1.5	G 1/2" A	15.4
DS-VA 16-S/R 3/4"/WD	16	S 400 (1700)	39.0	32	16	16	30	32	M 24x1.5	G 3/4" A	20.0
DS-VA 20-RS/WD	20	S 400 (1700)	43.0	32	20	16	36	32	M 30x2	G 3/4" A	25.3
DS-VA 25-RS/WD	25	S 400 (1700)	48.0	40	25	18	46	41	M 36x2	G 1" A	46.5
DS-VA 30-RS/WD	30	S 400 (1700)	51.0	50	30	20	50	50	M 42x2	G 1 1/4" A	64.4
DS-VA 38-RS/WD	38	S 400 (1700)	60.0	55	38	22	60	55	M 52x2	G 1 1/2" A	88.9

Please see "Engineering and technical data - Selecting the correct tube fitting" for more information on pressure.

COUPLINGS

STANDPIPE COUPLING

VA STUD STANDPIPE COUPLING

THE WORLD OF TUBE FITTINGS

VA STUD STANDPIPE COUPLING METRIC

These parts are ready mounted not pre-assembled.

After screwing on by hand, tighten with a spanner until tight, and then apply final 30° turn.

Metric parallel with stud.

Final assembled according to DIN 3955.

Captive seal NBR (e.g. Perbunan), FPM (e.g. Viton) upon request.

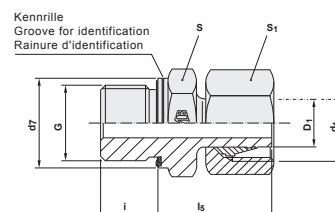

description	pipe OD	PN series	l_5	d_7	D_1	i	S_1	S	d_1	G	kg / 100 pcs
DS-VA 6-ML/WD	6	L 500 (2200)	24.5	14	6	8	14	14	M 12x1.5	M 10x1	2.5
DS-VA 8-ML/WD	8	L 500 (2200)	26.5	17	8	12	17	17	M 14x1.5	M 12x1.5	4.0
DS-VA 10-ML/WD	10	L 500 (2200)	27.5	19	10	12	19	19	M 16x1.5	M 14x1.5	4.7
DS-VA 12-ML/WD	12	L 400 (1700)	30.5	22	12	12	22	22	M 18x1.5	M 16x1.5	6.3
DS-VA 15-ML/WD	15	L 400 (1700)	31.5	24	15	12	27	24	M 22x1.5	M 18x1.5	9.5
DS-VA 18-ML/WD	18	L 400 (1700)	31.5	27	18	14	32	27	M 26x1.5	M 22x1.5	12.9
DS-VA 22-ML/WD	22	L 250 (1100)	32.5	32	22	16	36	32	M 30x2	M 26x1.5	17.6
DS-VA 28-ML/WD	28	L 250 (1100)	35.0	40	28	18	41	41	M 36x2	M 33x2	24.7
DS-VA 35-ML/WD	35	L 250 (1100)	42.5	50	35	20	50	50	M 45x2	M 42x2	40.7
DS-VA 42-ML/WD	42	L 250 (1100)	46.5	55	42	22	60	55	M 52x2	M 48x2	45.6
DS-VA 6-MS/WD	6	S 800 (3400)	27.0	17	6	12	17	17	M 14x1.5	M 12x1.5	4.5
DS-VA 8-MS/WD	8	S 800 (3400)	29.5	19	8	12	19	19	M 16x1.5	M 14x1.5	5.5
DS-VA 10-MS/WD	10	S 800 (3400)	32.0	22	10	12	22	22	M 18x1.5	M 16x1.5	8.2
DS-VA 12-MS/WD	12	S 630 (2700)	34.0	24	12	12	24	24	M 20x1.5	M 18x1.5	10.5
DS-VA 14-MS/WD	14	S 630 (2700)	36.5	26	14	14	27	27	M 22x1.5	M 20x1.5	14.8
DS-VA 16-MS/WD	16	S 630 (2700)	37.0	27	16	14	30	27	M 24x1.5	M 22x1.5	15.4
DS-VA 20-MS/WD	20	S 400 (1700)	43.0	32	20	16	36	32	M 30x2	M 27x2	25.3
DS-VA 25-MS/WD	25	S 400 (1700)	48.0	40	25	18	46	41	M 36x2	M 33x2	46.5
DS-VA 30-MS/WD	30	S 400 (1700)	51.0	50	30	20	50	50	M 42x2	M 42x2	64.4
DS-VA 38-MS/WD	38	S 400 (1700)	60.0	55	38	22	60	55	M 52x2	M 48x2	88.9

Please see "Engineering and technical data - Selecting the correct tube fitting" for more information on pressure.

COUPLINGS

STANDPIPE COUPLING

VA STUD STANDPIPE COUPLING

VA STUD STANDPIPE COUPLING NPT

These parts are ready mounted not pre-assembled.

After screwing on by hand, tighten with a spanner until tight, and then apply final 30° turn.

NPT (ANSI, ASME B1-20.1.1983).

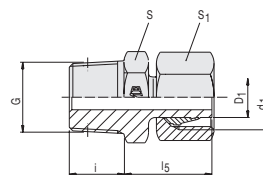

description	pipe OD	PN series	l_5	D_1	i	S_1	S	d_1	G	kg / 100 pcs
DS-VA 6-L/NPT	6	L 315 (1260)	24.0	6	10.0	14	11	M 12x1.5	1/8" NPT	2.6
DS-VA 8-L/NPT	8	L 315 (1260)	27.5	8	15.0	17	14	M 14x1.5	1/4" NPT	4.1
DS-VA 10-L/NPT	10	L 315 (1260)	25.5	10	15.0	19	14	M 16x1.5	1/4" NPT	4.8
DS-VA 12-L/NPT	12	L 315 (1260)	31.5	12	15.0	22	19	M 18x1.5	3/8" NPT	6.5
DS-VA 15-L/NPT	15	L 315 (1260)	29.0	15	20.0	27	22	M 22x1.5	1/2" NPT	11.0
DS-VA 18-L/NPT	18	L 315 (1260)	28.5	18	20.0	32	22	M 26x1.5	1/2" NPT	13.5
DS-VA 22-L/NPT	22	L 160 (640)	29.5	22	20.0	36	27	M 30x2	3/4" NPT	19.0
DS-VA 28-L/NPT	28	L 160 (640)	32.0	28	25.0	41	36	M 36x2	1" NPT	27.4
DS-VA 35-L/NPT	35	L 160 (640)	39.5	35	25.5	50	46	M 45x2	1 1/4" NPT	40.5
DS-VA 42-L/NPT	42	L 160 (640)	43.5	42	26.0	60	50	M 52x2	1 1/2" NPT	57.5
DS-VA 6-S/NPT	6	S 630 (2520)	25.0	6	15.0	17	14	M 14x1.5	1/4" NPT	5.0
DS-VA 8-S/NPT	8	S 630 (2520)	27.5	8	15.0	19	14	M 16x1.5	1/4" NPT	5.5
DS-VA 10-S/NPT	10	S 630 (2520)	29.5	10	15.0	22	19	M 18x1.5	3/8" NPT	8.0
DS-VA 12-S/NPT	12	S 630 (2520)	31.5	12	15.0	24	19	M 20x1.5	3/8" NPT	10.0
DS-VA 14-S/NPT	14	S 630 (2520)	33.5	14	20.0	27	22	M 22x1.5	1/2" NPT	14.9
DS-VA 16-S/NPT	16	S 630 (2520)	34.0	16	20.0	30	22	M 24x1.5	1/2" NPT	16.4
DS-VA 20-S/NPT	20	S 400 (1600)	40.0	20	20.0	36	27	M 30x2	3/4" NPT	25.0
DS-VA 25-S/NPT	25	S 400 (1600)	45.0	25	25.0	46	36	M 36x2	1" NPT	47.0
DS-VA 30-S/NPT	30	S 400 (1600)	48.0	30	25.5	50	46	M 42x2	1 1/4" NPT	61.9
DS-VA 38-S/NPT	38	S 400 (1600)	56.5	38	26.0	60	50	M 52x2	1 1/2" NPT	88.9

Please see "Engineering and technical data - Selecting the correct tube fitting" for more information on pressure.

COUPLINGS

STANDPIPE COUPLING

VADKO STUD STANDPIPE ADAPTOR

THE WORLD OF TUBE FITTINGS

VADKO STUD STANDPIPE ADAPTOR BSP

BSP parallel.

With taper and O-ring according to DIN 3865.

Captive seal NBR (e.g. Perbunan),
FPM (e.g. Viton) upon request.

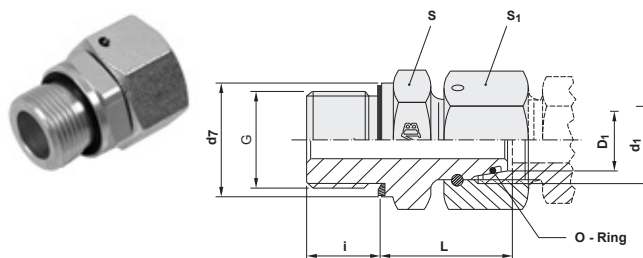

description	pipe OD	PN series	L	i	d ₇	G	D ₁	d ₁	S	S ₁	kg / 100 pcs	O-Ring
VADKO 6-RL/WD	6	L 500 [2200]	24.5	8	14	G 1/8" A	6	M 12x1.5	14	17	2.4	4x1.5
VADKO 8-RL/WD	8	L 500 [2200]	29.5	12	19	G 1/4" A	8	M 14x1.5	19	17	4.4	6x1.5
VADKO 10-RL/WD	10	L 500 [2200]	27.5	12	19	G 1/4" A	10	M 16x1.5	19	19	4.7	7.5x1.5
VADKO 12-RL/R1/4"/WD	12	L 400 [1700]	27.5	12	19	G 1/4" A	12	M 18x1.5	19	22	6.8	9x1.5
VADKO 12-RL/WD	12	L 400 [1700]	34.0	12	22	G 3/8" A	12	M 18x1.5	22	22	6.9	9x1.5
VADKO 15-RL/WD	15	L 400 [1700]	32.0	14	27	G 1/2" A	15	M 22x1.5	27	27	12.1	12x2
VADKO 18-RL/WD	18	L 400 [1700]	31.5	14	27	G 1/2" A	18	M 26x1.5	27	32	13.4	15x2
VADKO 22-RL/WD	22	L 250 [1100]	32.5	16	32	G 3/4" A	22	M 30x2	32	36	19.6	20x2
VADKO 28-RL/WD	28	L 250 [1100]	35.0	18	40	G 1" A	28	M 36x2	41	41	36.0	26x2
VADKO 35-RL/WD	35	L 250 [1100]	42.5	20	50	G 1 1/4" A	35	M 45x2	50	50	45.5	32x2.5
VADKO 42-RL/WD	42	L 250 [1100]	46.5	22	55	G 1 1/2" A	42	M 52x2	55	60	66.2	38x2.5
VADKO 6-RS/WD	6	S 800 [3400]	27.0	12	19	G 1/4" A	6	M 14x1.5	19	17	4.5	4x1.5
VADKO 8-RS/WD	8	S 800 [3400]	29.5	12	19	G 1/4" A	8	M 16x1.5	19	19	5.0	6x1.5
VADKO 10-RS/WD	10	S 800 [3400]	32.0	12	22	G 3/8" A	10	M 18x1.5	22	22	7.4	7.5x1.5
VADKO 12-RS/WD	12	S 630 [2700]	34.0	12	22	G 3/8" A	12	M 20x1.5	22	24	8.2	9x1.5
VADKO 12-S/R1/2"/WD	12	S 630 [2700]	34.5	14	27	G 1/2" A	12	M 20x1.5	27	24	15.3	9x1.5
VADKO 14-RS/WD	14	S 630 [2700]	36.5	14	27	G 1/2" A	14	M 22x1.5	27	27	12.6	10x2
VADKO 16-RS/WD	16	S 630 [2700]	37.0	14	27	G 1/2" A	16	M 24x1.5	27	30	14.6	12x2
VADKO 20-RS/WD	20	S 400 [1700]	43.0	16	32	G 3/4" A	20	M 30x2	32	36	22.1	16.3x2.4
VADKO 25-RS/WD	25	S 400 [1700]	48.0	18	40	G 1" A	25	M 36x2	41	46	40.2	20.3x2.4
VADKO 30-RS/WD	30	S 400 [1700]	51.0	20	50	G 1 1/4" A	30	M 42x2	50	50	58.2	25.3x2.4
VADKO 38-RS/WD	38	S 400 [1700]	60.0	22	55	G 1 1/2" A	38	M 52x2	55	60	78.6	33.3x2.4

Please see "Engineering and technical data - Selecting the correct tube fitting" for more information on pressure.

COUPLINGS

STANDPIPE COUPLING

VADKO STUD STANDPIPE ADAPTOR

VADKO STUD STANDPIPE ADAPTOR METRIC

Metric parallel.

With taper and O-ring according to DIN 3865.

Captive seal NBR (e.g. Perbunan), FPM (e.g. Viton) upon request.

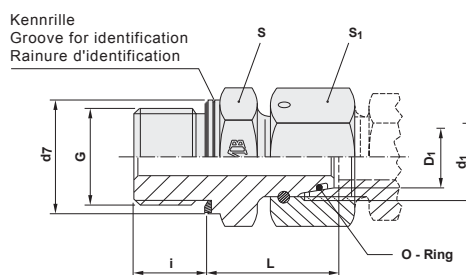

description	pipe OD	PN series	L	i	d ₇	G	D ₁	d ₁	S	S ₁	kg / 100 pcs	O-Ring
VADKO 6-ML/WD	6	L 500 (2200)	24.5	8	14	M 10x1	6	M 12x1.5	14	17	2.3	4 x1.5
VADKO 8-ML/WD	8	L 500 (2200)	26.5	12	17	M 12x1.5	8	M 14x1.5	17	17	3.8	6 x1.5
VADKO 10-ML/WD	10	L 500 (2200)	27.5	12	19	M 14x1.5	10	M 16x1.5	19	19	4.8	7.5x1.5
VADKO 12-ML/WD	12	L 400 (1700)	30.5	12	22	M 16x1.5	12	M 18x1.5	22	22	6.7	9 x1.5
VADKO 15-ML/WD	15	L 400 (1700)	31.5	12	24	M 18x1.5	15	M 22x1.5	24	27	10.1	12x2
VADKO 18-ML/WD	18	L 400 (1700)	31.5	14	27	M 22x1.5	18	M 26x1.5	27	32	13.8	15x2
VADKO 22-ML/WD	22	L 250 (1100)	32.5	16	32	M 26x1.5	22	M 30x2	32	36	19.9	20x2
VADKO 28-ML/WD	28	L 250 (1100)	35.0	18	40	M 33x2	28	M 36x2	41	41	35.8	26x2
VADKO 35-ML/WD	35	L 250 (1100)	42.5	20	50	M 42x2	35	M 45x2	50	50	45.0	32x2.5
VADKO 42-ML/WD	42	L 250 (1100)	46.5	22	55	M 48x2	42	M 52x2	55	60	70.8	38x2.5
VADKO 6-MS/WD	6	S 800 (3400)	27.0	12	17	M 12x1.5	6	M 14x1.5	17	17	4.0	4x1.5
VADKO 8-MS/WD	8	S 800 (3400)	29.5	12	19	M 14x1.5	8	M 16x1.5	19	19	5.1	6x1.5
VADKO 10-MS/WD	10	S 800 (3400)	32.0	12	22	M 16x1.5	10	M 18x1.5	22	22	7.1	7.5x1.5
VADKO 12-MS/WD	12	S 630 (2700)	34.0	12	24	M 18x1.5	12	M 20x1.5	24	24	8.9	9x1.5
VADKO 14-MS/WD	14	S 630 (2700)	36.5	14	26	M 20x1.5	14	M 22x1.5	27	27	12.1	10x2
VADKO 16-MS/WD	16	S 630 (2700)	37.0	14	27	M 22x1.5	16	M 24x1.5	27	30	14.8	12x2
VADKO 20-MS/WD	20	S 400 (1700)	43.0	16	32	M 27x2	20	M 30x2	32	36	22.3	16.3x2.4
VADKO 25-MS/WD	25	S 400 (1700)	48.0	18	40	M 33x2	25	M 36x2	41	46	40.0	20.3x2.4
VADKO 30-MS/WD	30	S 400 (1700)	51.0	20	50	M 42x2	30	M 42x2	50	50	58.3	25.3x2.4
VADKO 38-MS/WD	38	S 400 (1700)	60.0	22	55	M 48x2	38	M 52x2	55	60	78.2	33.3x2.4

Please see "Engineering and technical data - Selecting the correct tube fitting" for more information on pressure.

COUPLINGS

STANDPIPE COUPLING

VADKO STUD STANDPIPE ADAPTOR

THE WORLD OF TUBE FITTINGS

VADKO STUD STANDPIPE ADAPTOR NPT

NPT (ANSI, ASME B1-20.1.1983).

With taper and O-ring according to DIN 3865.

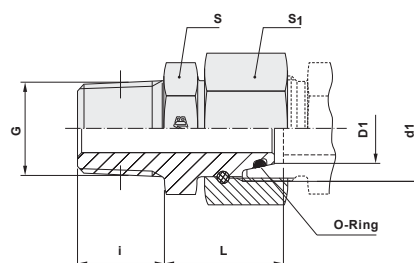

description	pipe OD	PN series	L	i	G	D ₁	d ₁	S	S ₁	kg / 100 pcs	O-Ring
VADKO 6-L/NPT	6	L 315 (1260)	20.5	10.0	1/8"NPT	6	M 12x1.5	11	17	2.3	4x1.5
VADKO 8-L/NPT	8	L 315 (1260)	22.5	15.0	1/4"NPT	8	M 14x1.5	14	17	4.1	6x1.5
VADKO 10-L/NPT	10	L 315 (1260)	23.0	15.0	1/4"NPT	10	M 16x1.5	14	19	4.4	7.5x1.5
VADKO 12-L/NPT	12	L 315 (1260)	24.7	15.3	3/8"NPT	12	M 18x1.5	19	22	6.9	9x1.5
VADKO 15-L/NPT	15	L 315 (1260)	29.5	20.0	1/2"NPT	15	M 22x1.5	22	27	12.7	2x2
VADKO 18-L/NPT	18	L 315 (1260)	29.0	20.0	1/2"NPT	18	M 26x1.5	24	32	14.2	15x2
VADKO 22-L/NPT	22	L 160 (640)	32.0	20.0	3/4"NPT	22	M 30x2	27	36	20.0	20x2
VADKO 28-L/NPT	28	L 160 (640)	36.0	25.0	1" NPT	28	M 36x2	36	41	30.6	26x2
VADKO 35-L/NPT	35	L 160 (640)	40.0	25.5	1 1/4" NPT	35	M 45x2	46	50	48.6	32x2.5
VADKO 42-L/NPT	42	L 160 (640)	42.5	26.0	1 1/2" NPT	42	M 52x2	50	60	66.2	38x2.5
VADKO 6-S/NPT	6	S 630 (2520)	22.5	15.0	1/4"NPT	6	M 14x1.5	14	17	4.2	4x1.5
VADKO 8-S/NPT	8	S 630 (2520)	23.0	15.0	1/4"NPT	8	M 16x1.5	14	19	4.7	6x1.5
VADKO 10-S/NPT	10	S 630 (2520)	25.2	15.3	3/8"NPT	10	M 18x1.5	19	22	7.5	7.5x1.5
VADKO 12-S/NPT	12	S 630 (2520)	26.7	15.3	3/8"NPT	12	M 20x1.5	19	24	8.1	9x1.5
VADKO 14-S/NPT	14	S 630 (2520)	30.5	20.0	1/2"NPT	14	M 22x1.5	22	27	13.1	10x2
VADKO 16-S/NPT	16	S 630 (2520)	31.0	20.0	1/2"NPT	16	M 24x1.5	22	30	14.5	12x2
VADKO 20-S/NPT	20	S 400 (1600)	34.0	20.0	3/4"NPT	20	M 30x2	27	36	22.1	16.3x2.4
VADKO 25-S/NPT	25	S 400 (1600)	38.5	25.0	1" NPT	25	M 36x2	36	46	42.2	20.3x2.4
VADKO 30-S/NPT	30	S 400 (1600)	45.0	25.5	1 1/4" NPT	30	M 42x2	46	50	62.8	25.3x2.4
VADKO 38-S/NPT	38	S 400 (1600)	47.5	26.0	1 1/2" NPT	38	M 52x2	50	60	77.0	33.3x2.4

Please see "Engineering and technical data - Selecting the correct tube fitting" for more information on pressure.

COUPLINGS

STRAIGHT COUPLING AND REDUCER

EDKO STRAIGHT COUPLING TAPER

Taper on both ends and O-ring to DIN 3865.

O-ring NBR (e.g. Perbunan), according to FPM (e.g. Viton) upon request.

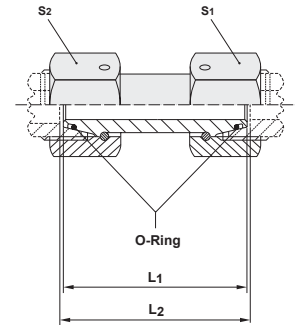

description	pipe OD	PN series	L ₁	L ₂	S ₁	O-Ring
EDKO 6-L	6	L 500 (2200)	33.0	36.0	17	4x1.5
EDKO 8-L	8	L 500 (2200)	33.0	36.0	17	6x1.5
EDKO 10-L	10	L 500 (2200)	35.0	37.0	19	7.5x1.5
EDKO 12-L	12	L 400 (1700)	35.0	37.0	22	9x1.5
EDKO 15-L	15	L 400 (1700)	38.0	40.0	27	12x2
EDKO 18-L	18	L 400 (1700)	39.5	42.5	32	15x2
EDKO 22-L	22	L 250 (1100)	44.0	47.0	36	20x2
EDKO 28-L	28	L 250 (1100)	46.0	49.0	41	26x2
EDKO 35-L	35	L 250 (1100)	52.0	58.0	50	32x2.5
EDKO 42-L	42	L 250 (1100)	52.0	59.0	60	38x2.5
EDKO 6-S	6	S 800 (3400)	36.0	39.0	17	4x1.5
EDKO 8-S	8	S 800 (3400)	36.0	39.0	19	6x1.5
EDKO 10-S	10	S 800 (3400)	40.0	43.0	22	7.5x1.5
EDKO 12-S	12	S 630 (2700)	41.0	44.0	24	9x1.5
EDKO 14-S	14	S 630 (2700)	44.0	48.0	27	10x2
EDKO 16-S	16	S 630 (2700)	45.0	50.0	30	12x2
EDKO 20-S	20	S 400 (1700)	54.0	60.0	36	16.3x2.4
EDKO 25-S	25	S 400 (1700)	59.0	66.0	46	20.3x2.4
EDKO 30-S	30	S 400 (1700)	63.0	73.0	50	25.3x2.4
EDKO 38-S	38	S 400 (1700)	68.0	83.0	60	33.3x2.4

Please see "Engineering and technical data - Selecting the correct tube fitting" for more information on pressure.

COUPLINGS STRAIGHT COUPLING AND REDUCER

THE WORLD OF TUBE FITTINGS

EDKOR STRAIGHT REDUCER COUPLING TAPER

Taper on both ends and O-ring to DIN 3865.

O-ring NBR (e.g. Perbunan), FPM (e.g. Viton) upon request.

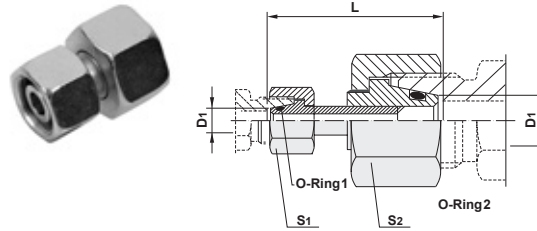

description	PB	pipe D ₁	pipe D ₂	L (± 2 mm)	S ₁	S ₂	O-Ring 1	O-Ring 2
EDKOR 6L/6S	500	6L	6S	35.0	14	17	4x1.5	4x1.5
EDKOR 6L/8L	500	6L	8L	34.0	14	17	4x1.5	6x1.5
EDKOR 6L/8S	500	6L	8S	37.0	14	19	4x1.5	6x1.5
EDKOR 6L/10L	500	6L	10L	34.0	14	19	4x1.5	7.5x1.5
EDKOR 6L/10S	500	6L	10S	35.0	14	22	4x1.5	7.5x1.5
EDKOR 8L/8S	500	8L	8S	37.0	17	19	6x1.5	6x1.5
EDKOR 8L/10L	500	8L	10L	34.0	17	19	6x1.5	7.5x1.5
EDKOR 8L/10S	500	8L	10S	35.0	17	22	6x1.5	7.5x1.5
EDKOR 8L/12L	500	8L	12L	34.0	17	22	6x1.5	9x1.5
EDKOR 8L/12S	500	8L	12S	35.0	17	24	6x1.5	9x1.5
EDKOR 10S/10L	500	10S	10L	37.0	22	19	7.5x1.5	7.5x1.5
EDKOR 10L/12L	500	10L	12L	36.0	19	22	7.5x1.5	9x1.5
EDKOR 10L/12S	500	10L	12S	37.0	19	24	7.5x1.5	9x1.5
EDKOR 10S/12L	400	10S	12L	36.0	22	22	7.5x1.5	9x1.5
EDKOR 10S/12S	630	10S	12S	37.0	22	24	7.5x1.5	9x1.5
EDKOR 10L/14S	500	10L	14S	39.0	19	27	7.5x1.5	10x2
EDKOR 10L/15L	400	10L	15L	34.0	19	27	7.5x1.5	12x2
EDKOR 10L/16S	500	10L	16S	39.0	19	30	7.5x1.5	12x2
EDKOR 12S/12L	400	12S	12L	40.0	24	22	9x1.5	9x1.5
EDKOR 12L/14S	400	12L	14S	38.0	22	27	9x1.5	10x2
EDKOR 12S/14S	630	12S	14S	38.0	24	27	9x1.5	10x2
EDKOR 12L/15L	400	12L	15L	36.0	22	27	9x1.5	12x2
EDKOR 12S/15L	400	12S	15L	35.0	24	27	9x1.5	12x2
EDKOR 12L/16S	400	12L	16S	38.0	22	30	9x1.5	12x2
EDKOR 12S/16S	630	12S	16S	38.0	24	30	9x1.5	12x2
EDKOR 12L/18L	400	12L	18L	36.0	22	32	9x1.5	15x2
EDKOR 12L/20S	400	12L	20S	44.0	22	36	9x1.5	16.3x2.4
EDKOR 14S/16S	630	14S	16S	42.0	27	30	10x2	12x2

Please see "Engineering and technical data - Selecting the correct tube fitting" for more information on pressure.

COUPLINGS

STRAIGHT COUPLING AND REDUCER

description	PB	pipe D ₁	pipe D ₂	L (± 2 mm)	S ₁	S ₂	O-Ring 1	O-Ring 2
EDKOR 15L/16S	400	15L	16S	39.0	27	30	12x2	12x2
EDKOR 15L/18L	400	15L	18L	38.0	27	32	12x2	15x2
EDKOR 15L/20S	400	15L	20S	44.0	27	36	12x2	16.3x2.4
EDKOR 15L/22L	250	15L	22L	42.0	27	36	12x2	20x2
EDKOR 15L/25S	400	15L	25S	50.0	27	46	12x2	20.3x2.4
EDKOR 16S/18L	400	16S	18L	41.0	30	32	12x2	15x2
EDKOR 16S/20S	400	16S	20S	47.0	30	36	12x2	16.3x2.4
EDKOR 16S/22L	250	16S	22L	44.0	30	36	12x2	20x2
EDKOR 16S/25S	400	16S	25S	48.0	30	46	12x2	20.3x2.4
EDKOR 18L/20S	400	18L	20S	46.0	32	36	15x2	16.3x2.4
EDKOR 18L/22L	250	18L	22L	41.0	32	36	15x2	20x2
EDKOR 18L/25S	400	18L	25S	47.0	32	46	15x2	20.3x2.4
EDKOR 18L/28L	250	18L	28L	47.0	32	41	15x2	26x2
EDKOR 18L/30S	400	18L	30S	52.0	32	50	15x2	25.3x2.4
EDKOR 20S/22L	250	20S	22L	46.0	36	36	16.3x2.4	20x2
EDKOR 20S/25S	400	20S	25S	55.0	36	46	16.3x2.4	20.3x2.4
EDKOR 20S/28L	250	20S	28L	50.0	36	41	16.3x2.4	26x2
EDKOR 20S/30S	400	20S	30S	60.0	36	50	16.3x2.4	25.3x2.4
EDKOR 22L/25S	250	22L	25S	47.0	36	46	20x2	20.3x2.4
EDKOR 22L/28L	250	22L	28L	41.0	36	41	20x2	26x2
EDKOR 22L/30S	250	22L	30S	49.0	36	50	20x2	25.3x2.4
EDKOR 22L/35L	250	22L	35L	48.0	36	50	20x2	32x2.5
EDKOR 22L/38S	250	22L	38S	51.0	36	60	20x2	33.3x2.4
EDKOR 25S/28L	250	25S	28L	48.0	46	41	20.3x2.4	26x2
EDKOR 25S/30S	400	25S	30S	57.0	46	50	20.3x2.4	25.3x2.4
EDKOR 25S/35L	250	25S	35L	62.0	46	50	20.3x2.4	32x2.5
EDKOR 25S/38S	400	25S	38S	95.0	46	60	20.3x2.4	33.3x2.4
EDKOR 28L/30S	250	28L	30S	50.0	41	50	26x2	25.3x2.4
EDKOR 28L/35L	250	28L	35L	51.0	41	50	26x2	32x2.5
EDKOR 28L/38S	250	28L	38S	50.0	41	60	26x2	33.3x2.4
EDKOR 28L/42L	250	28L	42L	50.0	41	60	26x2	38x2.5
EDKOR 30S/35L	250	30S	35L	58.0	50	50	25.3x2.4	32x2.5
EDKOR 30S/38S	400	30S	38S	57.0	50	60	25.3x2.4	33.3x2.4
EDKOR 30S/42L	250	30S	42L	58.0	50	60	25.3x2.4	38x2.5
EDKOR 35L/38S	250	35L	38S	57.0	50	60	32x2.5	33.3x2.4
EDKOR 35L/42L	250	35L	42L	59.0	50	60	32x2.5	38x2.5
EDKOR 38S/42L	250	38S	42L	62.0	60	60	33.3x2.4	38x2.5

Please see "Engineering and technical data - Selecting the correct tube fitting" for more information on pressure.

COUPLINGS

ADJUSTABLE LOCKNUT COUPLING

BE ADJUSTABLE LOCKNUT ELBOW

THE WORLD OF TUBE FITTINGS

BE ADJUSTABLE LOCKNUT ELBOW METRIC

Metric parallel.

ISO 6149 with O-ring seal.

O-ring NBR (e.g. Perbunan), FPM (e.g. Viton) upon request.

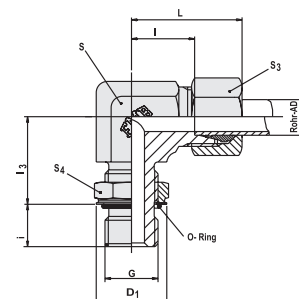

description	pipe OD	PN series	S ₄	S	S ₃	L	l	l ₃	D ₁	i	G	MA* Nm	O-Ring	kg / 100 pcs
BE 4-MLL/O	4	LL 250	12	11	10	21	11.5	19.8	13.3	7.1	M 8x1		6.1x1.6	2.5
BE 4-MLL/M10x1/O	4	LL 251	14	11	10	21	11.5	19.8	15.3	7.1	M 10x1		8.1x1.6	2.9
BE 6-MLL/O	6	LL 252	14	11	12	22	9.5	19.8	15.3	7.1	M 10x1		8.1x1.6	2.8
BE 6-MLL/M12x1.5/O	6	LL 253	17	14	12	25	12.5	23.2	18.6	9.6	M 12x1.5		9.3x2.2	4.9
DS-BE 6-ML/O	6	L 315	14	14	14	29	14.0	20.0	15.0	7.0	M 10x1	15	8.1x1.6	6.6
DS-BE 8-ML/O	8	L 315	17	14	17	31	16.0	22.0	18.0	10.0	M 12x1.5	25	9.3x2.2	6.6
DS-BE 10-ML/O	10	L 315	19	19	19	32	17.0	25.0	20.0	10.0	M 14x1.5	35	11.3x2.2	8.7
DS-BE 12-ML/O	12	L 315	22	19	22	34	19.0	26.0	23.0	10.0	M 16x1.5	40	13.3x2.2	9.5
DS-BE 15-ML/O	15	L 315	24	22	27	36	21.0	30.0	25.0	11.0	M 18x1.5	45	15.3x2.2	22.4
DS-BE 18-ML/O	18	L 315	27	27	32	40	24.0	33.0	28.0	12.0	M 22x1.5	60	19.3x2.2	28.4
DS-BE 22-ML/O	22	L 160	32	30	36	44	28.0	35.0	33.0	14.0	M 27x2	100	23.6x2.9	53.4
DS-BE 28-ML/O	28	L 160	41	36	41	47	31.0	38.0	41.0	14.0	M 33x2	160	29.6x2.9	60.7
DS-BE 35-ML/O	35	L 160	50	50	50	59	38.0	48.0	51.0	14.0	M 42x2	210	38.6x2.9	84.4
DS-BE 42-ML/O	42	L 160	55	50	60	61	38.0	49.0	56.0	16.0	M 48x2	260	44.6x2.9	92.8
DS-BE 6-MS/O	6	S 400	17	14	17	30	15.0	22.0	18.0	10.0	M 12x1.5	35	9.3x2.2	7.2
DS-BE 8-MS/O	8	S 400	19	19	19	32	17.0	26.0	20.0	10.0	M 14x1.5	45	11.3x2.2	8.8
DS-BE 10-MS/O	10	S 400	22	19	22	34	18.0	27.0	23.0	11.0	M 16x1.5	55	13.3x2.2	9.7
DS-BE 12-MS/O	12	S 400	24	22	24	38	22.0	31.0	25.0	12.0	M 18x1.5	70	15.3x2.2	22.7
DS-BE 16-MS/O	16	S 400	27	27	30	43	25.0	35.0	28.0	14.0	M 22x1.5	100	19.3x2.2	28.6
DS-BE 20-MS/O	20	S 400	32	30	36	49	28.0	39.0	33.0	16.0	M 27x2	170	23.6x2.9	55.3
DS-BE 25-MS/O	25	S 315	41	36	46	54	30.0	44.0	41.0	16.0	M 33x2	310	29.6x2.9	72.2
DS-BE 30-MS/O	30	S 250	50	50	50	62	36.0	51.0	51.0	17.0	M 42x2	330	38.6x2.9	93.2
DS-BE 38-MS/O	38	S 200	55	50	60	65	34.0	54.0	56.0	19.0	M 48x2	420	44.6x2.9	104.2

* Recommended tightening torques for stud threads G, with mating material steel

Please see "Engineering and technical data - Selecting the correct tube fitting" for more information on pressure.

COUPLINGS

ADJUSTABLE LOCKNUT COUPLING

BE ADJUSTABLE LOCKNUT ELBOW

BE ADJUSTABLE LOCKNUT ELBOW UNF/UN

UNF / UN parallel with O-ring seal.

O-ring NBR (e.g. Perbunan), FPM (e.g. Viton) upon request.

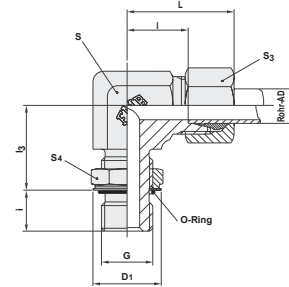

description	pipe OD	PN series	S ₄	S	S ₃	L	l	l ₃	D ₁	i	G	MA* Nm	O-Ring	kg / 100 pcs
DS-BE 6-L/7/16-20UNF	6	L 315	14	14	14	29	14	19	16.5	10	7/16-20UNF-2A	19	8.92x1.83	6.5
DS-BE 8-L/7/16-20UNF	8	L 315	14	14	17	31	16	19	16.5	10	7/16-20UNF-2A	19	8.92x1.83	7.0
DS-BE 10-L/9/16-18UNF	10	L 315	17	19	19	32	17	24	20.2	11	9/16-18UNF-2A	40	11.89x1.98	9.0
DS-BE 12-L/9/16-18UNF	12	L 315	17	19	22	34	19	25	20.2	11	9/16-18UNF-2A	40	11.89x1.98	11.0
DS-BE 12-L/3/4-16UNF	12	L 315	22	19	22	34	19	25	25.7	13	3/4-16UNF-2A	60	16.36x2.21	19.4
DS-BE 15-L/3/4-16UNF	15	L 315	22	22	27	36	21	28	25.7	13	3/4-16UNF-2A	60	16.36x2.21	18.5
DS-BE 15-L/7/8-14UNF	15	L 315	27	22	27	36	21	28	29.3	15	7/8-14UNF-2A	80	19.18x2.46	18.8
DS-BE 18-L/7/8-14UNF	18	L 315	27	27	32	40	24	32	29.3	15	7/8-14UNF-2A	80	19.18x2.46	28.4
DS-BE 18-L/1 1/16-12UN	18	L 315	32	30	32	40	24	32	36.7	17	1 1/16-12UN-2A	110	23.47x2.95	31.8
DS-BE 22-L/1 1/16-12UN	22	L 160	32	30	36	44	28	35	36.7	17	1 1/16-12UN-2A	110	23.47x2.95	53.5
DS-BE 28-L/1 5/16-12UN	28	L 160	41	36	41	47	31	42	44.0	17	1 5/16-12UN-2A	160	29.74x2.95	45.2
DS-BE 35-L/1 5/8-12UN	35	L 160	50	50	50	59	38	46	55.0	17	1 5/8-12UN-2A	300	37.46x3	84.4
DS-BE 42-L/1 7/8-12UN	42	L 160	55	50	60	61	38	47	62.3	17	1 7/8-12UN-2A	340	43.69x3	92.8
DS-BE 6-S/7/16-20UNF	6	S 400	14	14	17	30	15	20	16.5	11	7/16-20UNF-2A	21	8.92x1.83	6.5
DS-BE 8-S/9/16-18UNF	8	S 400	17	19	19	32	17	25	20.2	12	9/16-18UNF-2A	50	11.89x1.98	8.5
DS-BE 10-S/9/16-18UNF	10	S 400	17	19	22	34	18	26	20.2	12	9/16-18UNF-2A	50	11.89x1.98	9.0
DS-BE 12-S/3/4-16UNF	12	S 400	22	22	24	38	22	30	25.7	14	3/4-16UNF-2A	80	16.36x2.21	21.3
DS-BE 16-S/7/8-14UNF	16	S 400	27	27	30	43	25	34	29.3	16	7/8-14UNF-2A	140	19.18x2.46	28.6
DS-BE 20-S/1 1/16-12UN	20	S 400	32	30	36	49	28	37	36.7	19	1 1/16-12UN-2A	190	23.47x2.95	55.5
DS-BE 25-S/1 1/16-12UN	25	S 400	32	36	46	54	30	50	36.7	19	1 1/16-12UN-2A	190	23.47x2.95	69.4
DS-BE 30-S/1 5/8-12UN	30	S 250	50	50	50	62	36	50	55.0	19	1 5/8-12UN-2A	350	37.46x3	93.2
DS-BE 38-S/1 7/8-12UN	38	S 250	55	50	60	65	34	51	62.3	19	1 7/8-12UN-2A	430	43.69x3	104.2

* Recommended tightening torques for stud threads G, with mating material steel

Please see "Engineering and technical data - Selecting the correct tube fitting" for more information on pressure.

COUPLINGS

ADJUSTABLE LOCKNUT COUPLING

BE ADJUSTABLE LOCKNUT ELBOW

THE WORLD OF TUBE FITTINGS

BE ADJUSTABLE LOCKNUT ELBOW BSP RR

BSP parallel for small or wide spot face.

Retaining ring and O-ring NBR (e.g. Perbunan),
FPM (e.g. Viton) upon request.

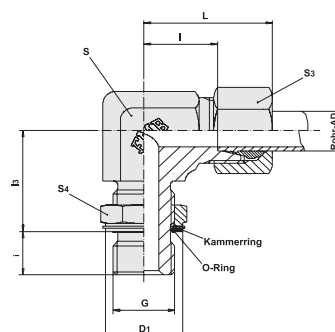

description	pipe OD	PN series	S ₄	S	S ₃	L	l	l ₃	D ₁	i	G	MA* Nm	O-Ring	Support ring small	kg / 100 pcs
BE 4-RL/0A	4	LL 250	14	11	10	21	11.3	20.5	15	5.5	G 1/8"A	10	8x1.88	KAM R1/3	3.0
BE 6-RL/0A	6	LL 250	14	11	12	21	11.3	20.5	15	5.5	G 1/8"A	10	8x1.88	KAM R1/8	3.2
DS-BE 6-RL/0A	6	L 315	14	14	14	29	14.0	20.5	15	5.5	G 1/8 A	25	8x1.88	KAM R1/8	6.6
DS-BE 8-RL/0A	8	L 315	19	14	17	31	16.0	25.5	20	7.0	G 1/4"A	50	10.77x2.62	KAM R1/4	6.6
DS-BE 10-RL/0A	10	L 315	19	19	19	32	17.0	27.0	20	7.0	G 1/4" A	50	10.77x2.62	KAM R1/4	11.9
DS-BE 12-RL/0A	12	L 250	22	19	22	34	19.0	30.0	23	7.0	G 3/8" A	80	13.94x2.62	KAM R3/8	13.8
DS-BE 15-RL/0A	15	L 250	27	22	27	36	21.0	32.5	28	10.5	G 1/2" A	105	17x3	KAM R1/2	28.3
DS-BE 18-RL/0A	18	L 250	27	27	32	40	24.0	38.5	28	10.5	G 1/2" A	105	17x3	KAM R1/2	34.4
DS-BE 22-RL/0A	22	L 160	36	30	36	44	28.0	38.5	33	10.5	G 3/4"A	220	23.6x2.9	KAM R3/4	44.9
DS-BE 28-RL/0A	28	L 160	41	36	41	47	31.0	46.5	41	12.5	G 1"A	370	29.74x3.53	KAM R1	65.7
DS-BE 35-RL/0A	35	L 160	50	50	50	59	38.0	52.5	51	12.5	G 1 1/4"A	500	37.69x3.53	KAM R1 1/4	111.3
DS-BE 42-RL/0A	42	L 160	55	50	60	61	38.0	54.5	56	12.5	G 1 1/2"A	600	44.04x3.53	KAM R1 1/2	119.7
DS-BE 6-RS/0A	6	S 315	19	14	17	30	15.0	25.0	20	7.0	G 1/4"A	50	10.77x2.62	KAM R1/4	6.9
DS-BE 8-RS/0A	8	S 315	19	19	19	32	17.0	27.0	20	7.0	G 1/4"A	50	10.77x2.62	KAM R1/4	12.0
DS-BE 10-RS/0A	10	S 250	22	19	22	34	18.0	30.0	23	7.0	G 3/8"A	80	13.94x2.62	KAM R3/8	13.8
DS-BE 12-RS/0A	12	S 250	22	22	24	38	22.0	30.0	23	7.0	G 3/8"A	80	13.94x2.62	KAM R3/8	20.6
DS-BE 16-RS/0A	16	S 250	27	27	30	43	25.0	38.5	28	10.5	G 1/2"A	105	17x3	KAM R1/2	34.6
DS-BE 20-RS/0A	20	S 250	36	30	36	49	28.0	38.5	33	10.5	G 3/4"A	220	23.6x2.9	KAM R3/4	46.8
DS-BE 25-RS/0A	25	S 250	41	36	46	54	30.0	46.5	41	12.5	G 1"A	370	29.74x3.53	KAM R1	77.2
DS-BE 30-RS/0A	30	S 160	50	50	50	62	36.0	51.5	51	12.5	G 1 1/4"A	500	37.69x3.53	KAM R1 1/4	106.9
DS-BE 38-RS/0A	38	S 160	55	50	60	65	34.0	57.5	56	12.5	G 1 1/2"A	600	44.04x3.53	KAM R1 1/2	131.1

* Recommended tightening torques for stud threads G, with mating material steel

Please see "Engineering and technical data - Selecting the correct tube fitting" for more information on pressure.

COUPLINGS

ADJUSTABLE LOCKNUT COUPLING

BE ADJUSTABLE LOCKNUT ELBOW

BE ADJUSTABLE LOCKNUT ELBOW METRIC RR

Metric parallel for small or wide spot face.

Retaining ring and O-ring NBR (e.g. Perbunan), FPM (e.g. Viton) upon request.

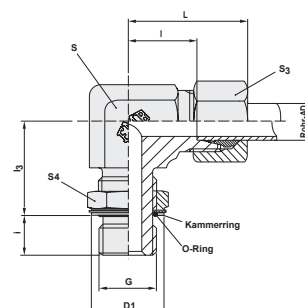

description	pipe OD	PN series	S ₄	S	S ₃	L	l	l ₃	D ₁	i	G	MA* Nm	O-Ring	Support ring small	kg / 100 pcs
DS-BE 6-ML/OA	6	L 315	14	14	14	29	14	21.5	15	5.5	M10x1	18	8x1.88	KAM M10x1	6.6
DS-BE 8-ML/OA	8	L 315	17	14	17	31	16	23.5	18	8.5	M12x1.5	35	9.3x2.2	KAM M12x1.5	6.6
DS-BE 10-ML/OA	10	L 315	19	19	19	32	17	26.5	20	8.5	M14x1.5	55	11.3x2.2	KAM M14x1.5	8.7
DS-BE 12-ML/OA	12	L 315	22	19	22	34	19	27.5	23	8.5	M16x1.5	80	13.3x2.2	KAM M16x1.5	9.5
DS-BE 15-ML/OA	15	L 315	24	22	27	36	21	32.0	25	9.0	M18x1.5	105	15.54x2.62	KAM M18x1.5	22.4
DS-BE 18-ML/OA	18	L 250	27	27	32	40	24	35.5	28	9.5	M22x1.5	125	19.2x3	KAM M22x1.5	28.4
DS-BE 22-ML/OA	22	L 160	32	30	36	44	28	37.5	33	11.5	M27x2	220	23.47x2.95	KAM M27x2	53.4
DS-BE 28-ML/OA	28	L 160	41	36	41	47	31	40.5	41	11.5	M33x2	370	29.2x3	KAM M33x2	60.9
DS-BE 35-ML/OA	35	L 160	50	50	50	59	38	50.5	51	11.5	M42x2	500	37.69x3.53	KAM M42x2	84.4
DS-BE 42-ML/OA	42	L 160	55	50	60	61	38	51.5	56	13.5	M48x2	600	43.69x3	KAM M48x2	92.4
DS-BE 6-MS/OA	6	S 315	17	14	17	30	15	23.5	18	8.5	M12x1.5	35	9.3x2.2	KAM M12x1.5	7.2
DS-BE 8-MS/OA	8	S 315	19	19	19	32	17	27.5	20	8.5	M14x1.5	55	11.3x2.2	KAM M14x1.5	8.8
DS-BE 10-MS/OA	10	S 315	22	19	22	34	18	28.5	23	9.5	M16x1.5	80	13.3x2.2	KAM M16x1.5	9.7
DS-BE 12-MS/OA	12	S 315	24	22	24	38	22	33.0	25	10.0	M18x1.5	105	15.54x2.62	KAM M18x1.5	22.7
DS-BE 16-MS/OA	16	S 250	27	27	30	43	25	37.5	28	11.5	M22x1.5	125	19.2x3	KAM M22x1.5	28.6
DS-BE 20-MS/OA	20	S 250	32	30	36	49	28	41.5	33	13.5	M27x2	220	23.47x2.95	KAM M27x2	55.3
DS-BE 25-MS/OA	25	S 160	41	36	46	54	30	46.5	41	13.5	M33x2	370	29.2x3	KAM M33x2	72.2
DS-BE 30-MS/OA	30	S 160	50	50	50	62	36	53.5	51	14.5	M42x2	500	37.69x3.53	KAM M42x2	93.2
DS-BE 38-MS/OA	38	S 160	55	50	60	65	34	56.5	56	16.5	M48x2	600	43.69x3	KAM M48x2	104.2

* Recommended tightening torques for stud threads G, with mating material steel

Please see "Engineering and technical data - Selecting the correct tube fitting" for more information on pressure.

COUPLINGS

ADJUSTABLE LOCKNUT COUPLING

BFE ADJUSTABLE 45° LOCKNUT ELBOW

THE WORLD OF TUBE FITTINGS

BFE ADJUSTABLE 45° LOCKNUT ELBOW METRIC

Metric parallel.

ISO 6149 with O-ring seal.

O-ring NBR (e.g. Perbunan), FPM (e.g. Viton) upon request.

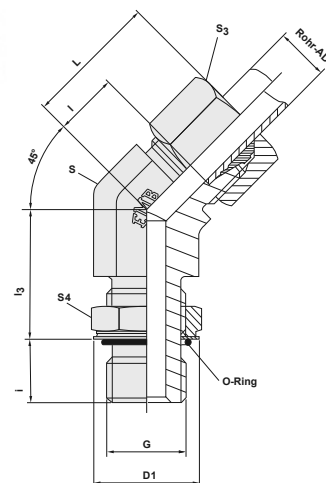

description	pipe OD	PN series	S ₄	S	S ₃	L	l	l ₃	D ₁	i	G	MA* Nm	O-Ring	kg / 100 pcs
DS-BFE 6-ML/O	6	L 315	14	14	14	24	9	19	15	7	M10x1	15	8.1x1.6	9.3
DS-BFE 8-ML/O	8	L 315	17	14	17	27	12	19	18	10	M12x1.5	25	9.3x2.2	10.3
DS-BFE 10-ML/O	10	L 315	19	19	19	27	12	24	20	10	M14x1.5	35	11.3x2.2	17.5
DS-BFE 12-ML/O	12	L 315	22	19	22	28	14	24	23	10	M16x1.5	40	13.3x2.2	19.1
DS-BFE 15-ML/O	15	L 315	24	22	27	32	17	24	25	11	M18x1.5	45	15.3x2.2	33.1
DS-BFE 18-ML/O	18	L 315	27	27	32	33	17	30	28	12	M22x1.5	60	19.3x2.2	42.3
DS-BFE 22-ML/O	22	L 160	32	30	36	35	19	33	33	14	M27x2	100	23.6x2.9	73.7
DS-BFE 28-ML/O	28	L 160	41	36	41	40	23	35	41	14	M33x2	160	29.6x2.9	77.7
DS-BFE 35-ML/O	35	L 160	50	50	50	48	27	37	51	14	M42x2	210	38.6x2.9	126.0
DS-BFE 42-ML/O	42	L 160	55	50	60	49	26	37	56	16	M48x2	260	44.6x2.9	142.8
DS-BFE 6-MS/O	6	S 400	17	14	17	24	9	18	18	10	M12x1.5	35	9.3x2.2	10.6
DS-BFE 8-MS/O	8	S 400	19	19	19	27	12	21	20	10	M14x1.5	45	11.3x2.2	17.7
DS-BFE 10-MS/O	10	S 400	22	19	22	29	13	21	23	11	M16x1.5	55	13.3x2.2	19.5
DS-BFE 12-MS/O	12	S 400	24	22	24	33	17	22	25	12	M18x1.5	70	15.3x2.2	31.3
DS-BFE 16-MS/O	16	S 400	27	27	30	34	16	29	28	14	M22x1.5	100	19.3x2.2	42.7
DS-BFE 20-MS/O	20	S 400	32	30	36	38	16	31	33	16	M27x2	170	23.6x2.9	77.5
DS-BFE 25-MS/O	25	S 250	41	36	46	43	19	33	41	16	M33x2	310	29.6x2.9	100.7
DS-BFE 30-MS/O	30	S 200	50	50	50	50	24	35	51	17	M42x2	330	38.6x2.9	143.6
DS-BFE 38-MS/O	38	S 200	55	50	60	52	21	35	56	19	M48x2	420	44.6x2.9	165.6

* Recommended tightening torques for stud threads G, with mating material steel

Please see "Engineering and technical data - Selecting the correct tube fitting" for more information on pressure.

COUPLINGS

ADJUSTABLE LOCKNUT COUPLING

BFE ADJUSTABLE 45° LOCKNUT ELBOW

BFE ADJUSTABLE 45° LOCKNUT ELBOW UNF/UN

UNF / UN parallel with O-ring seal.

O-ring NBR (e.g. Perbunan), FPM (e.g. Viton) upon request.

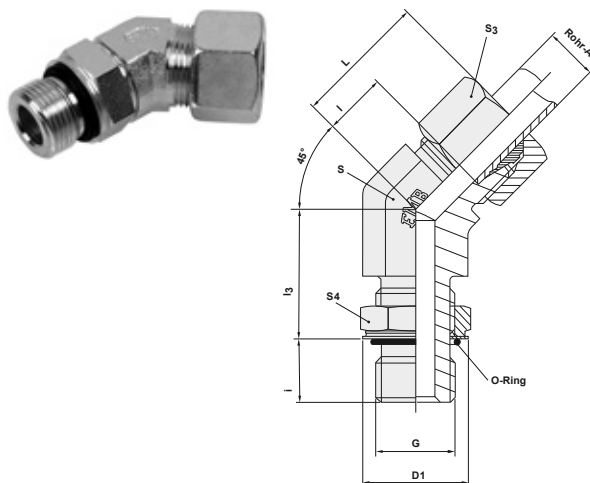

description	pipe OD	PN series	S ₄	S	S ₃	L	l	L ₃	D ₁	i	G	MA* Nm	O-Ring	kg / 100 pcs
DS-BFE 6-L/7/16-20UNF	6	L 315	14	14	14	24	9	19	16.5	10	7/16-20UNF-2A	19	8.92x1.83	5.7
DS-BFE 8-L/7/16-20UNF	8	L 315	14	14	17	27	12	19	16.5	10	7/16-20UNF-2A	19	8.92x1.83	6.2
DS-BFE 10-L/9/16-18UNF	10	L 315	17	19	19	27	12	24	20.2	11	9/16-18UNF-2A	40	11.89x1.98	10.5
DS-BFE 12-L/9/16-18UNF	12	L 315	17	19	22	28	14	24	20.2	11	9/16-18UNF-2A	40	11.89x1.98	10.1
DS-BFE 12-L/3/4-16UNF	12	L 315	22	19	22	28	14	24	25.7	13	3/4-16UNF-2A	60	16.36x2.21	14.7
DS-BFE 15-L/3/4-16UNF	15	L 315	22	22	27	32	17	24	25.7	13	3/4-16UNF-2A	60	16.36x2.21	20.3
DS-BFE 15-L/7/8-14UNF	15	L 315	27	22	27	32	17	24	29.3	15	7/8-14UNF-2A	80	19.18x2.46	18.0
DS-BFE 18-L/7/8-14UNF	18	L 315	27	27	32	33	17	30	29.3	15	7/8-14UNF-2A	80	19.18x2.46	26.4
DS-BFE 18-L/1 1/6-12UN	18	L 160	32	30	32	33	17	30	36.7	17	1 1/16-12UN-2A	110	23.47x2.95	36.4
DS-BFE 22-L/1 1/6-12UN	22	L 160	32	30	36	35	19	33	36.7	17	1 1/16-12UN-2A	110	23.47x2.95	38.8
DS-BFE 28-L/1 5/16-12UN	28	L 160	41	36	41	39	23	35	44.0	17	1 5/16-12UN-2A	160	29.74x2.95	50.0
DS-BFE 35-L/1 5/8-12UN	35	L 160	50	50	50	48	27	37	55.0	17	1 5/8-12UN-2A	300	37.46x3	73.1
DS-BFE 42-L/1 7/8-12UN	42	L 16	55	50	60	49	26	37	62.3	17	1 7/8-12UN-2A	340	43.69x3	81.5
DS-BFE 6-S/7/16-20UNF	6	S 400	14	14	17	24	9	18	16.5	11	7/16-20UNF-2A	21	8.92x1.83	6.5
DS-BFE 8-S/9/16-18UNF	8	S 400	17	19	19	27	12	21	20.2	12	9/16-18UNF-2A	50	11.89x1.98	10.6
DS-BFE 10-S/9/16-18UNF	10	S 400	17	19	22	29	13	21	20.2	12	9/16-18UNF-2A	50	11.89x1.98	11.5
DS-BFE 12-S/3/4-16UNF	12	S 400	22	22	24	33	17	22	25.7	14	3/4-16UNF-2A	80	16.36x2.21	17.1
DS-BFE 16-S/7/8-14UNF	16	S 400	27	27	30	34	16	29	29.3	16	7/8-14UNF-2A	140	19.18x2.46	26.6
DS-BFE 20-S/1 1/16-12UN	20	S 400	32	30	36	38	16	31	36.7	19	1 1/16-12UN-2A	190	23.47x2.95	40.7
DS-BFE 25-S/1 1/16-12UN	25	S 400	32	36	46	43	19	33	36.7	19	1 1/16-12UN-2A	190	23.47x2.95	55.8
DS-BFE 30-S/1 5/8-12UN	30	S 250	50	50	50	50	24	35	55.0	19	1 5/8-12UN-2A	350	37.46x3	81.9
DS-BFE 38-S/1 7/8-12UN	38	S 250	55	50	60	52	21	35	62.3	19	1 7/8-12UN-2A	430	43.69x3	92.9

* Recommended tightening torques for stud threads G, with mating material steel

Please see "Engineering and technical data - Selecting the correct tube fitting" for more information on pressure.

COUPLINGS

ADJUSTABLE LOCKNUT COUPLING

BFE ADJUSTABLE 45° LOCKNUT ELBOW

THE WORLD OF TUBE FITTINGS

BFE ADJUSTABLE 45° LOCKNUT ELBOW BSP RR

BSP parallel for small or wide spot face.

Retaining ring and O-ring NBR (e.g. Perbunan),
FPM (e.g. Viton) upon request.

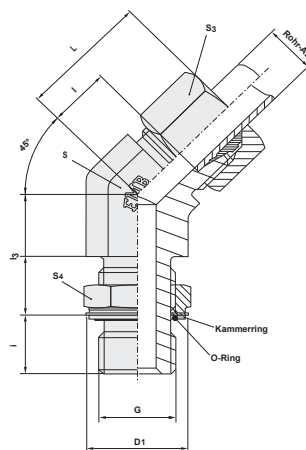

description	pipe OD	PN series	S ₄	S	S ₃	L	l	l ₃	D ₁	i	G	MA* Nm	O-Ring	Support ring small	kg / 100 pcs
DS-BFE 6-RL/OA	6	L 315	14	4	14	24	9	24.5	15	5.5	G 1/8"A	25	8x1.88	KAM R1/8	9.3
DS-BFE 8-RL/OA	8	L 315	19	14	17	27	12	21.0	20	7.0	G 1/4"A	50	10.77x2.62	KAM R1/4	10.3
DS-BFE 10-RL/OA	10	L 315	19	19	19	27	12	25.0	20	7.0	G 1/4"A	50	10.77x2.62	KAM R1/4	17.1
DS-BFE 12-RL/OA	12	L 250	22	19	22	28	14	27.0	23	7.0	G 3/8"A	80	13.94x2.62	KAM R3/8	20.6
DS-BFE 15-RL/OA	15	L 250	27	22	27	32	17	27.5	28	10.5	G 1/2"A	105	17x3	KAM R1/2	31.3
DS-BFE 18-RL/OA	18	L 250	27	27	32	33	17	33.5	28	10.5	G 1/2"A	105	17x3	KAM R1/2	42.8
DS-BFE 22-RL/OA	22	L 160	36	30	36	35	19	36.5	33	10.5	G 3/4"A	220	23.6x2.9	KAM R3/4	71.9
DS-BFE 28-RL/OA	28	L 160	41	36	41	40	23	39.5	41	12.5	G 1"A	370	29.74x3.53	KAM R1	81.2
DS-BFE 35-RL/OA	35	L 160	50	50	50	48	27	40.5	51	12.5	G 1 1/4"A	500	37.69x3.53	KAM R1 1/4	126.0
DS-BFE 42-RL/OA	42	L 160	55	50	60	49	26	40.5	56	12.5	G 1 1/2"A	600	44.04x3.53	KAM R1 1/2	142.8
DS-BFE 6-RS/OA	6	S 315	19	14	17	24	9	21.0	20	7.0	G 1/4"A	50	10.77x2.62	KAM R1/4	10.9
DS-BFE 8-RS/OA	8	S 315	19	19	19	27	12	25.0	20	7.0	G 1/4"A	50	10.77x2.62	KAM R1/4	15.3
DS-BFE 10-RS/OA	10	S 250	22	19	22	29	13	27.0	23	7.0	G 3/8"A	80	13.94x2.62	KAM R3/8	19.1
DS-BFE 12-RS/OA	12	S 250	22	22	24	33	17	27.0	23	7.0	G 3/8"A	80	13.94x2.62	KAM R3/8	23.8
DS-BFE 16-RS/OA	16	S 250	27	27	30	34	16	33.5	28	10.5	G 1/2"A	105	17x3	KAM R1/2	43.2
DS-BFE 20-RS/OA	20	S 250	36	30	36	38	16	36.5	33	10.5	G 3/4"A	220	23.6x2.9	KAM R3/4	75.7
DS-BFE 25-RS/OA	25	S 250	41	36	46	43	19	39.5	41	12.5	G 1"A	370	29.74x3.53	KAM R1	104.2
DS-BFE 30-RS/OA	30	S 160	50	50	50	50	24	40.5	51	12.5	G 1 1/4"A	500	37.69x3.53	KAM R1 1/4	143.6
DS-BFE 38-RS/OA	38	S 160	55	50	60	52	21	40.5	56	12.5	G 1 1/2"A	600	44.04x3.53	KAM R1 1/2	165.6

* Recommended tightening torques for stud threads G, with mating material steel

Please see "Engineering and technical data - Selecting the correct tube fitting" for more information on pressure.

COUPLINGS

ADJUSTABLE LOCKNUT COUPLING

BFE ADJUSTABLE 45° LOCKNUT ELBOW

BFE ADJUSTABLE 45° LOCKNUT ELBOW METRIC RR

Metric parallel for small or wide spot face.

Retaining ring and O-ring NBR (e.g. Perbunan),
FPM (e.g. Viton) upon request.

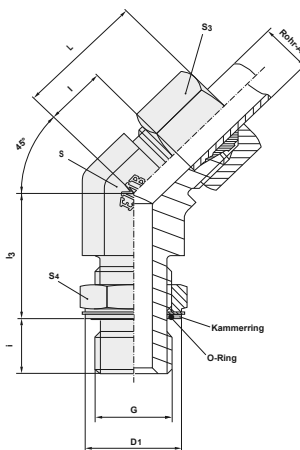

description	pipe OD	PN series	S ₄	S	S ₃	L	l	L ₃	D ₁	i	G	MA* Nm	O-Ring	Support ring small	kg / 100 pcs
DS-BFE 6-ML/OA	6	L 315	14	14	14	24	9	20.5	15	5.5	M10x1	18	8x1.88	KAM M10x1	5.7
DS-BFE 8-ML/OA	8	L 315	17	14	17	27	12	20.5	18	8.5	M12x1.5	35	9.3x2.2	KAM M12x1.5	6.2
DS-BFE 10-ML/OA	10	L 315	19	19	19	27	12	25.5	20	8.5	M14x1.5	55	11.3x2.2	KAM M14x1.5	10.4
DS-BFE 12-ML/OA	12	L 315	22	19	22	28	14	25.5	23	8.5	M16x1.5	80	13.3x2.2	KAM M16x1.5	14.0
DS-BFE 15-ML/OA	15	L 315	24	22	27	32	17	26.0	25	9.0	M18x1.5	105	15.54x2.62	KAM M18x1.5	19.8
DS-BFE 18-ML/OA	18	L 250	27	27	32	33	17	32.5	28	9.5	M22x1.5	125	19.2x3	KAM M22x1.5	26.0
DS-BFE 22-ML/OA	22	L 160	32	30	36	35	19	35.5	33	11.5	M27x2	220	23.47x2.95	KAM M27x2	38.2
DS-BFE 28-ML/OA	28	L 160	41	36	41	40	23	37.5	41	11.5	M33x2	370	29.2x3	KAM M33x2	40.6
DS-BFE 35-ML/OA	35	L 160	50	50	50	48	27	39.5	51	11.5	M42x2	500	37.69x3.53	KAM M42x2	72.9
DS-BFE 42-ML/OA	42	L 160	55	50	60	49	26	39.5	56	13.5	M48x2	600	43.69x3	KAM M48x2	81.3
DS-BFE 6-MS/OA	6	S 315	17	14	17	24	9	19.5	18	8.5	M12x1.5	35	9.3x2.2	KAM M12x1.5	6.4
DS-BFE 8-MS/OA	8	S 315	19	19	19	27	12	22.5	20	8.5	M14x1.5	55	11.3x2.2	KAM M14x1.5	10.5
DS-BFE 10-MS/OA	10	S 315	22	19	22	29	13	22.5	23	9.5	M16x1.5	80	13.3x2.2	KAM M16x1.5	11.4
DS-BFE 12-MS/OA	12	S 315	24	22	24	33	17	24.0	25	10.0	M18x1.5	105	15.54x2.62	KAM M18x1.5	14.9
DS-BFE 16-MS/OA	16	S 250	27	27	30	34	16	31.5	28	11.5	M22x1.5	125	19.2x3	KAM M22x1.5	22.2
DS-BFE 20-MS/OA	20	S 250	32	30	36	38	16	33.5	33	13.5	M27x2	220	23.47x2.95	KAM M27x2	40.1
DS-BFE 25-MS/OA	25	S 160	41	36	46	43	19	35.5	41	13.5	M33x2	370	29.2x3	KAM M33x2	52.1
DS-BFE 30-MS/OA	30	S 160	50	50	50	50	24	37.5	51	14.5	M42x2	500	37.69x3.53	KAM M42x2	81.7
DS-BFE 38-MS/OA	38	S 160	55	50	60	52	21	37.5	56	16.5	M48x2	600	43.69x3	KAM M48x2	92.7

* Recommended tightening torques for stud threads G, with mating material steel

Please see "Engineering and technical data - Selecting the correct tube fitting" for more information on pressure.

COUPLINGS

ADJUSTABLE LOCKNUT COUPLING

CE ADJUSTABLE LOCKNUT BRANCH TEE

THE WORLD OF TUBE FITTINGS

CE ADJUSTABLE LOCKNUT BRANCH TEE METRIC

Metric parallel.

ISO 6149 with O-ring seal.

O-ring NBR (e.g. Perbunan), FPM (e.g. Viton) upon request.

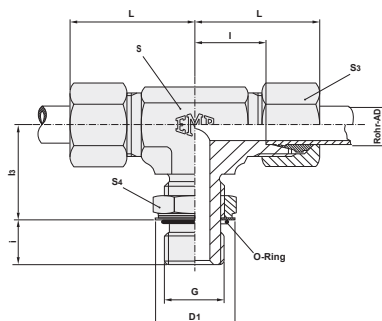

description	pipe OD	PN series	S ₄	S	S ₃	L	l	l ₃	D ₁	i	G	MA* Nm	O-Ring	kg / 100 pcs
DS-CE 6-ML/O	6	L 315	14	14	14	29	14	20	15	7	M 10x1	15	8.1x1.6	9.3
DS-CE 8-ML/O	8	L 315	17	14	17	31	16	22	18	10	M 12x1.5	25	9.3x2.2	10.3
DS-CE 10-ML/O	10	L 315	19	19	19	32	17	25	20	10	M 14x1.5	35	11.3x2.2	17.5
DS-CE 12-ML/O	12	L 315	22	19	22	34	19	26	23	10	M 16x1.5	40	13.3x2.2	19.1
DS-CE 15-ML/O	15	L 315	24	22	27	36	21	30	25	11	M 18x1.5	45	15.3x2.2	33.1
DS-CE 18-ML/O	18	L 315	27	27	32	40	24	33	28	12	M 22x1.5	60	19.3x2.2	42.3
DS-CE 22-ML/O	22	L 160	32	30	36	44	28	35	33	14	M 27x2	100	23.6x2.9	73.7
DS-CE 28-ML/O	28	L 160	41	36	41	47	31	38	41	14	M 33x2	160	29.6x2.9	77.7
DS-CE 35-ML/O	35	L 160	50	50	50	59	38	48	51	14	M 42x2	210	38.6x2.9	126.0
DS-CE 42-ML/O	42	L 160	55	50	60	61	38	49	56	16	M 48x2	260	44.6x2.9	142.8
DS-CE 6-MS/O	6	S 400	17	14	17	30	15	22	18	10	M 12x1.5	35	9.3x2.2	10.6
DS-CE 8-MS/O	8	S 400	19	19	19	32	17	26	20	10	M 14x1.5	45	11.3x2.2	17.7
DS-CE 10-MS/O	10	S 400	22	19	22	34	18	27	23	11	M 16x1.5	55	13.3x2.2	19.5
DS-CE 12-MS/O	12	S 400	24	22	24	38	22	31	25	12	M 18x1.5	70	15.3x2.2	31.3
DS-CE 16-MS/O	16	S 400	27	27	30	43	25	35	28	14	M 22x1.5	100	19.3x2.2	42.7
DS-CE 20-MS/O	20	S 400	32	30	36	49	28	39	33	16	M 27x2	170	23.6x2.9	77.5
DS-CE 25-MS/O	25	S 315	41	36	46	54	30	44	41	16	M 33x2	310	29.6x2.9	100.7
DS-CE 30-MS/O	30	S 250	50	50	50	62	36	51	51	17	M 42x2	330	38.6x2.9	143.6
DS-CE 38-MS/O	38	S 200	55	50	60	65	34	54	56	19	M 48x2	420	44.6x2.9	165.6

* Recommended tightening torques for stud threads G, with mating material steel

Please see "Engineering and technical data - Selecting the correct tube fitting" for more information on pressure.

COUPLINGS

ADJUSTABLE LOCKNUT COUPLING

CE ADJUSTABLE LOCKNUT BRANCH TEE

CE ADJUSTABLE LOCKNUT BRANCH TEE UNF/UN

UNF / UN parallel with O-ring seal.

O-ring NBR (e.g. Perbunan), FPM (e.g. Viton) upon request.

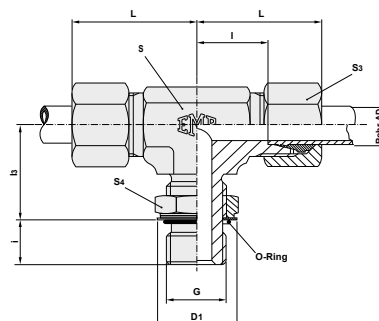

description	pipe OD	PN series	S ₄	S	S ₃	L	l	l ₃	D ₁	i	G	MA* Nm	O-Ring	kg / 100 pcs
DS-CE 6-L/7/16-20UNF	6	L 315	14	14	14	29	14	19	16.5	10	7/16-20UNF-2A	19	8.92x1.83	9.1
DS-CE 8-L/7/16-20UNF	8	L 315	14	14	17	31	16	19	16.5	10	7/16-20UNF-2A	19	8.92x1.83	10.1
DS-CE 10-L/9/16-18UNF	10	L 315	17	19	19	32	17	24	20.2	11	9/16-18UNF-2A	40	11.89x1.98	17.5
DS-CE 12-L/9/16-18UNF	12	L 315	17	19	22	34	19	25	20.2	11	9/16-18UNF-2A	40	11.89x1.98	19.5
DS-CE 12-L/3/4-16UNF	12	L 315	22	19	22	34	19	25	25.7	13	3/4-16UNF-2A	60	16.36x2.21	24.7
DS-CE 15-L/3/4-16UNF	15	L 315	22	22	27	36	21	28	25.7	13	3/4-16UNF-2A	60	16.36x2.21	32.9
DS-CE 15-L/7/8-14UNF	15	L 315	27	22	27	36	21	28	29.3	15	7/8-14UNF-2A	80	19.18x2.46	32.9
DS-CE 18-L/7/8-14UNF	18	L 315	27	27	32	40	24	32	29.3	15	7/8-14UNF-2A	80	19.18x2.46	41.9
DS-CE 18-L/1 1/16-12UN	18	L 315	32	30	32	40	24	32	36.7	17	1 1/16-12UN-2A	110	23.47x2.95	58.1
DS-CE 22-L/1 1/16-12UN	22	L 160	32	30	36	44	28	35	36.7	17	1 1/16-12UN-2A	110	23.47x2.95	62.9
DS-CE 28-L/1 5/16-12UN	28	L 160	41	36	41	47	31	42	44.0	17	1 5/16-12UN-2A	160	29.74x2.95	75.1
DS-CE 35-L/1 5/8-12UN	35	L 160	50	50	50	59	38	46	55.0	17	1 5/8-12UN-2A	300	37.46x3	126.2
DS-CE 42-L/1 7/8-12UN	42	L 160	55	50	60	61	38	47	62.3	17	1 7/8-12UN-2A	340	43.69x3	148.2
DS-CE 6-S/7/16-20UNF	6	S 400	14	14	17	30	15	20	16.5	11	7/16-20UNF-2A	21	8.92x1.83	10.7
DS-CE 8-S/9/16-18UNF	8	S 400	17	19	19	32	17	25	20.2	12	9/16-18UNF-2A	50	11.89x1.98	17.7
DS-CE 10-S/9/16-18UNF	10	S 400	17	19	22	34	18	26	20.2	12	9/16-18UNF-2A	50	11.89x1.98	19.5
DS-CE 12-S/3/4-16UNF	12	S 400	22	22	24	38	22	30	25.7	14	3/4-16UNF-2A	80	16.36x2.21	31.1
DS-CE 16-S/7/8-14UNF	16	S 400	27	27	30	43	25	34	29.3	16	7/8-14UNF-2A	140	19.18x2.46	42.3
DS-CE 20-S/1 1/16-12UN	20	S 400	32	30	36	49	28	37	36.7	19	1 1/16-12UN-2A	190	23.47x2.95	66.7
DS-CE 25-S/1 1/16-12UN	25	S 400	32	36	46	54	30	50	36.7	19	1 1/16-12UN-2A	190	23.47x2.95	98.1
DS-CE 30-S/1 5/8-12UN	30	S 250	50	50	50	62	36	50	55.0	19	1 5/8-12UN-2A	350	37.46x3	143.8
DS-CE 38-S/1 7/8-12UN	38	S 250	55	50	60	65	34	51	63.0	19	1 7/8-12UN-2A	430	43.69x3	165.8

* Recommended tightening torques for stud threads G, with mating material steel

Please see "Engineering and technical data - Selecting the correct tube fitting" for more information on pressure.

COUPLINGS

ADJUSTABLE LOCKNUT COUPLING

CE ADJUSTABLE LOCKNUT BRANCH TEE

THE WORLD OF TUBE FITTINGS

CE ADJUSTABLE LOCKNUT BRANCH TEE BSP RR

BSP parallel for small or wide spot face.

Retaining ring and O-ring NBR (e.g. Perbunan), FPM (e.g. Viton) upon request.

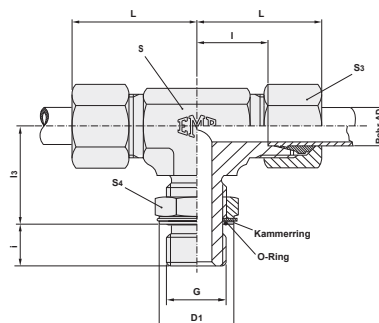

description	pipe OD	PN series	S ₄	S	S ₃	L	l	l ₃	D ₁	i	G	MA* Nm	O-Ring	Support ring small	kg / 100 pcs
DS-CE 6-RL/OA	6	L 315	14	14	14	29	14	20.5	15	5.5	G 1/8"A	25	8x1.88	KAM R1/8	9.3
DS-CE 8-RL/OA	8	L 315	19	14	17	31	16	25.0	20	7.0	G 1/4"A	50	10.77x2.62	KAM R1/4	10.3
DS-CE 10-RL/OA	10	L 315	19	19	19	32	17	27.0	20	7.0	G 1/4"A	50	10.77x2.62	KAM R1/4	17.1
DS-CE 12-RL/OA	12	L 250	22	19	22	34	19	30.0	23	7.0	G 3/8"A	80	13.94x2.62	KAM R3/8	20.6
DS-CE 15-RL/OA	15	L 250	27	22	27	36	21	32.5	28	10.5	G 1/2"A	105	17x3	KAM R1/2	31.3
DS-CE 18-RL/OA	18	L 250	27	27	32	40	24	38.5	28	10.5	G 1/2"A	105	17x3	KAM R1/2	42.8
DS-CE 22-RL/OA	22	L 160	36	30	36	44	28	38.5	33	10.5	G 3/4"A	220	23.6x2.9	KAM R3/4	71.9
DS-CE 28-RL/OA	28	L 160	41	36	41	47	31	46.5	41	12.5	G 1"A	370	29.74x3.53	KAM R1	81.2
DS-CE 35-RL/OA	35	L 160	50	50	50	59	38	52.5	51	12.5	G 1 1/4"A	500	37.69x3.53	KAM R1 1/4	126.0
DS-CE 42-RL/OA	42	L 160	55	50	60	61	38	54.5	56	12.5	G 1 1/2"A	600	44.04x3.53	KAM R1 1/2	142.8
DS-CE 6-RS/OA	6	S 315	19	14	17	30	15	25.0	20	7.0	G 1/4"A	50	10.77x2.62	KAM R1/4	10.9
DS-CE 8-RS/OA	8	S 315	19	19	19	32	17	27.0	20	7.0	G 1/4"A	50	10.77x2.62	KAM R1/4	15.3
DS-CE 10-RS/OA	10	S 250	22	19	22	34	18	30.0	23	7.0	G 3/8"A	80	13.94x2.62	KAM R3/8	19.1
DS-CE 12-RS/OA	12	S 250	22	22	24	38	22	30.0	23	7.0	G 3/8"A	80	13.94x2.62	KAM R3/8	23.8
DS-CE 16-RS/OA	16	S 250	27	27	30	43	25	38.5	28	10.5	G 1/2"A	105	17x3	KAM R1/2	43.2
DS-CE 20-RS/OA	20	S 250	36	30	36	49	28	38.5	33	10.5	G 3/4"A	220	23.6x2.9	KAM R3/4	75.7
DS-CE 25-RS/OA	25	S 250	41	36	46	54	30	46.5	41	12.5	G 1"A	370	29.74x3.53	KAM R1	104.2
DS-CE 30-RS/OA	30	S 160	50	50	50	62	36	51.5	51	12.5	G 1 1/4"A	500	37.69x3.53	KAM R1 1/4	143.6
DS-CE 38-RS/OA	38	S 160	55	50	60	65	34	57.5	56	12.5	G 1 1/2"A	600	44.04x3.53	KAM R1 1/2	165.6

* Recommended tightening torques for stud threads G, with mating material steel

Please see "Engineering and technical data - Selecting the correct tube fitting" for more information on pressure.

COUPLINGS

ADJUSTABLE LOCKNUT COUPLING

CE ADJUSTABLE LOCKNUT BRANCH TEE

CE ADJUSTABLE LOCKNUT BRANCH TEE METRIC RR

Metric parallel for small or wide spot face.

Retaining ring and O-ring NBR (e.g. Perbunan), FPM (e.g. Viton) upon request.

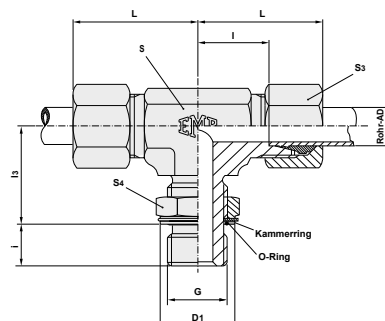

description	pipe OD	PN series	S ₄	S	S ₃	L	l	l ₃	D ₁	i	G	MA* Nm	O-Ring	Support ring small	kg / 100 pcs
DS-CE 6-ML/OA	6	L 315	14	14	14	29	14	21.5	15	5.5	M 10x1	18	8x1.88	KAM M10x1	9.3
DS-CE 8-ML/OA	8	L 315	17	14	17	31	16	23.5	18	8.5	M 12x1.5	35	9.3x2.2	KAM M12x1.5	10.3
DS-CE 10-ML/OA	10	L 315	19	19	19	32	17	26.5	20	8.5	M 14x1.5	55	11.3x2.2	KAM M14x1.5	17.5
DS-CE 12-ML/OA	12	L 315	22	19	22	34	19	27.5	23	8.5	M 16x1.5	80	13.3x2.2	KAM M16x1.5	19.1
DS-CE 15-ML/OA	15	L 315	24	22	27	36	21	32.0	25	9.0	M 18x1.5	105	15.54x2.62	KAM M18x1.5	33.1
DS-CE 18-ML/OA	18	L 250	27	27	32	40	24	35.5	28	9.5	M 22x1.5	125	19.2x3	KAM M22x1.5	42.3
DS-CE 22-ML/OA	22	L 160	32	30	36	44	28	37.5	33	11.5	M 27x2	220	23.47x2.95	KAM M27x2	73.7
DS-CE 28-ML/OA	28	L 160	41	36	41	47	31	40.5	41	11.5	M 33x2	370	29.2x3	KAM M33x2	77.7
DS-CE 35-ML/OA	35	L 160	50	50	50	59	38	50.5	51	11.5	M 42x2	500	37.69x3.53	KAM M42x2	126.0
DS-CE 42-ML/OA	42	L 160	55	50	60	61	38	51.5	56	13.5	M 48x2	600	43.69x3	KAM M48x2	142.8
DS-CE 6-MS/OA	6	S 315	17	14	17	30	15	23.5	18	8.5	M 12x1.5	35	9.3x2.2	KAM M12x1.5	10.6
DS-CE 8-MS/OA	8	S 315	19	19	19	32	17	27.5	20	8.5	M 14x1.5	55	11.3x2.2	KAM M14x1.5	17.7
DS-CE 10-MS/OA	10	S 315	22	19	22	34	18	28.5	23	9.5	M 16x1.5	80	13.3x2.2	KAM M16x1.5	19.5
DS-CE 12-MS/OA	12	S 315	24	22	24	38	22	33.0	25	10.0	M 18x1.5	105	15.54x2.62	KAM M18x1.5	31.3
DS-CE 16-MS/OA	16	S 250	27	27	30	43	25	37.5	28	11.5	M 22x1.5	125	19.2x3	KAM M22x1.5	42.7
DS-CE 20-MS/OA	20	S 250	32	30	36	49	28	41.5	33	13.5	M 27x2	220	23.47x2.95	KAM M27x2	77.5
DS-CE 25-MS/OA	25	S 160	41	36	46	54	30	46.5	41	13.5	M 33x2	370	29.2x3	KAM M33x2	100.7
DS-CE 30-MS/OA	30	S 160	50	50	50	62	36	53.5	51	14.5	M 42x2	500	37.69x3.53	KAM M42x2	143.6
DS-CE 38-MS/OA	38	S 160	55	50	60	65	34	56.5	56	16.5	M 48x2	600	43.69x3	KAM M48x2	165.6

* Recommended tightening torques for stud threads G, with mating material steel

Please see "Engineering and technical data - Selecting the correct tube fitting" for more information on pressure.

COUPLINGS

ADJUSTABLE LOCKNUT COUPLING

DE ADJUSTABLE LOCKNUT RUN TEE

THE WORLD OF TUBE FITTINGS

DE ADJUSTABLE LOCKNUT RUN TEE METRIC

Metric parallel.

ISO 6149 with O-ring seal.

O-ring NBR (e.g. Perbunan), FPM (e.g. Viton) upon request.

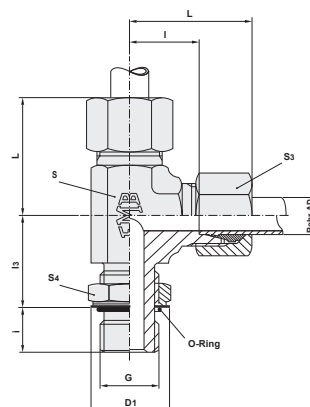

description	pipe OD	PN series	S ₄	S	S ₃	L	l	l ₃	D ₁	i	G	MA* Nm	O-Ring	kg / 100 pcs
DS-DE 6-ML/O	6	L 315	14	14	14	29	14	20	15	7	M 10x1	15	8.1x1.6	9.3
DS-DE 8-ML/O	8	L 315	17	14	17	31	16	22	18	10	M 12x1.5	25	9.3x2.2	10.3
DS-DE 10-ML/O	10	L 315	19	19	19	32	17	25	20	10	M 14x1.5	35	11.3x2.2	17.5
DS-DE 12-ML/O	12	L 315	22	19	22	34	19	26	23	10	M 16x1.5	40	13.3x2.2	19.1
DS-DE 15-ML/O	15	L 315	24	22	27	36	21	30	25	11	M 18x1.5	45	15.3x2.2	33.1
DS-DE 18-ML/O	18	L 315	27	27	32	40	24	33	28	12	M 22x1.5	60	19.3x2.2	42.3
DS-DE 22-ML/O	22	L 160	32	30	36	44	28	35	33	14	M 27x2	100	23.6x2.9	73.7
DS-DE 28-ML/O	28	L 160	41	36	41	47	31	38	41	14	M 33x2	160	29.6x2.9	77.7
DS-DE 35-ML/O	35	L 160	50	50	50	59	38	48	51	14	M 42x2	210	38.6x2.9	126.0
DS-DE 42-ML/O	42	L 160	55	50	60	61	38	49	56	16	M 48x2	260	44.6x2.9	142.8
DS-DE 6-MS/O	6	S 400	17	14	17	30	15	22	18	10	M 12x1.5	35	9.3x2.2	10.6
DS-DE 8-MS/O	8	S 400	19	19	19	32	17	26	20	10	M 14x1.5	45	11.3x2.2	17.7
DS-DE 10-MS/O	10	S 400	22	19	22	34	18	27	23	11	M 16x1.5	55	13.3x2.2	19.5
DS-DE 12-MS/O	12	S 400	24	22	24	38	22	31	25	12	M 18x1.5	70	15.3x2.2	31.3
DS-DE 16-MS/O	16	S 400	27	27	30	43	25	35	28	14	M 22x1.5	100	19.3x2.2	42.7
DS-DE 20-MS/O	20	S 400	32	30	36	49	28	39	33	16	M 27x2	170	23.6x2.9	77.5
DS-DE 25-MS/O	25	S 250	41	36	46	54	30	44	41	16	M 33x2	310	29.6x2.9	100.7
DS-DE 30-MS/O	30	S 200	50	50	50	62	36	51	51	17	M 42x2	330	38.6x2.9	143.6
DS-DE 38-MS/O	38	S 200	55	50	60	65	34	54	56	19	M 48x2	420	44.6x2.9	165.6

* Recommended tightening torques for stud threads G, with mating material steel

Please see "Engineering and technical data - Selecting the correct tube fitting" for more information on pressure.

COUPLINGS

ADJUSTABLE LOCKNUT COUPLING

DE ADJUSTABLE LOCKNUT RUN TEE

DE ADJUSTABLE LOCKNUT RUN TEE UNF/UN

UNF / UN parallel with O-ring seal.

ISO 6149 with O-ring seal.

O-ring NBR (e.g. Perbunan), FPM (e.g. Viton) upon request.

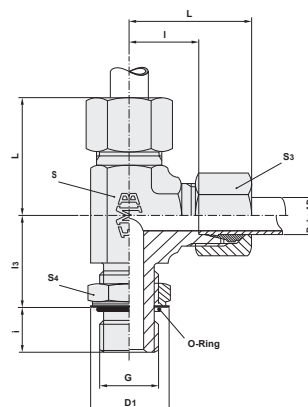

description	pipe OD	PN series	S ₄	S	S ₃	L	l	l ₃	D ₁	i	G	MA* Nm	O-Ring	kg / 100 pcs
DS-DE 6-L/7/16-20UNF	6	L 315	14	14	14	29	14	19	16.5	10	7/16-20UNF-2A	19	8.92x1.83	9.1
DS-DE 8-L/7/16-20UNF	8	L 315	14	14	17	31	16	19	16.5	10	7/16-20UNF-2A	19	8.92x1.83	10.1
DS-DE 10-L/9/16-18UNF	10	L 315	17	19	19	32	17	24	20.2	11	9/16-18UNF-2A	40	11.89x1.98	17.5
DS-DE 12-L/9/16-18UNF	12	L 315	17	19	22	34	19	25	20.2	11	9/16-18UNF-2A	40	11.89x1.98	19.5
DS-DE 12-L/3/4-16UNF	12	L 315	22	19	22	34	19	25	25.7	13	3/4-16UNF-2A	60	16.36x2.21	24.7
DS-DE 15-L/3/4-16UNF	15	L 315	22	22	27	36	21	28	25.7	13	3/4-16UNF-2A	60	16.36x2.21	32.9
DS-DE 15-L/7/8-14UNF	15	L 315	27	22	27	36	21	28	29.3	15	7/8-14UNF-2A	80	19.18x2.46	32.9
DS-DE 18-L/7/8-14UNF	18	L 315	27	27	32	40	24	32	29.3	15	7/8-14UNF-2A	80	19.18x2.46	41.9
DS-DE 18-L/1 1/6-12UN	18	L 315	32	30	32	40	24	32	36.7	17	1 1/6-12UN-2A	110	23.47x2.95	58.1
DS-DE 22-L/1 1/6-12UN	22	L 160	32	30	36	44	28	35	36.7	17	1 1/6-12UN-2A	110	23.47x2.95	62.9
DS-DE 28-L/1 5/8-12UN	28	L 160	41	36	41	47	31	42	44.0	17	1 5/8-12UN-2A	160	29.74x2.95	75.1
DS-DE 35-L/1 5/8-12UN	35	L 160	50	50	50	59	38	46	55.0	17	1 5/8-12UN-2A	300	37.46x3	126.2
DS-DE 42-L/1 7/8-12UN	42	L 160	55	50	60	61	38	47	62.3	17	1 7/8-12UN-2A	340	43.69x3	148.2
DS-DE 6-S/7/16-20UNF	6	S 400	14	14	17	30	15	20	16.5	11	7/16-20UNF-2A	21	8.92x1.83	10.7
DS-DE 8-S/9/16-18UNF	8	S 400	17	19	19	32	17	25	20.2	12	9/16-18UNF-2A	50	11.89x1.98	17.7
DS-DE 10-S/9/16-18UNF	10	S 400	17	19	22	34	18	26	20.2	12	9/16-18UNF-2A	50	11.89x1.98	19.5
DS-DE 12-S/3/4-16UNF	12	S 400	22	22	24	38	22	30	25.7	14	3/4-16UNF-2A	80	16.36x2.21	31.1
DS-DE 16-S/7/8-14UNF	16	S 400	27	27	30	43	25	34	29.3	16	7/8-14UNF-2A	140	19.18x2.46	42.3
DS-DE 20-S/1 1/6-12UN	20	S 400	32	30	36	49	28	37	36.7	19	1 1/6-12UN-2A	190	23.47x2.95	66.7
DS-DE 25-S/1 1/6-12UN	25	S 400	32	36	46	54	30	50	36.7	19	1 1/6-12UN-2A	190	23.47x2.95	98.1
DS-DE 30-S/1 5/8-12UN	30	S 250	50	50	50	62	36	50	55.0	19	1 5/8-12UN-2A	350	37.46x3	143.8
DS-DE 38-S/1 7/8-12UN	38	S 250	55	50	60	65	34	51	63.0	19	1 7/8-12UN-2A	430	43.69x3	165.8

* Recommended tightening torques for stud threads G, with mating material steel

Please see "Engineering and technical data - Selecting the correct tube fitting" for more information on pressure.

COUPLINGS

ADJUSTABLE LOCKNUT COUPLING

DE ADJUSTABLE LOCKNUT RUN TEE

THE WORLD OF TUBE FITTINGS

DE ADJUSTABLE LOCKNUT RUN TEE BSP RR

BSP parallel for small or wide spot face.

Retaining ring and O-ring NBR (e.g. Perbunan), FPM (e.g. Viton) upon request.

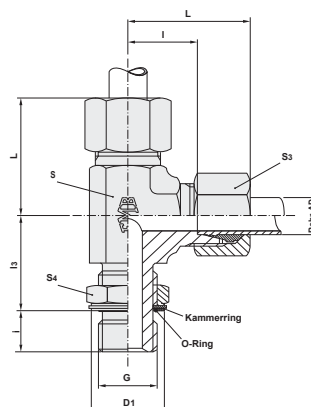

description	pipe OD	PN series	S ₄	S	S ₃	L	l	l ₃	D ₁	i	G	MA* Nm	O-Ring	Support ring small	kg / 100 pcs
DS-DE 6-RL/OA	6	L 315	14	14	14	29	14	20.5	15	5.5	G 1/8"A	25	8x1.88	KAM R1/8	9.3
DS-DE 8-RL/OA	8	L 315	19	14	17	31	16	25.0	20	7.0	G 1/4"A	50	10.77x2.62	KAM R1/4	10.3
DS-DE 10-RL/OA	10	L 315	19	19	19	32	17	27.0	20	7.0	G 1/4"A	50	10.77x2.62	KAM R1/4	17.1
DS-DE 12-RL/OA	12	L 250	22	19	22	34	19	30.0	23	7.0	G 3/8"A	80	13.94x2.62	KAM R3/8	20.6
DS-DE 15-RL/OA	15	L 250	27	22	27	36	21	32.5	28	10.5	G 1/2"A	105	17x3	KAM R1/2	31.3
DS-DE 18-RL/OA	18	L 250	27	27	32	40	24	38.5	28	10.5	G 1/2"A	105	17x3	KAM R1/2	42.8
DS-DE 22-RL/OA	22	L 160	36	30	36	44	28	38.5	33	10.5	G 3/4"A	220	23.6x2.9	KAM R3/4	71.9
DS-DE 28-RL/OA	28	L 160	41	36	41	47	31	46.5	41	12.5	G 1"A	370	29.74x3.53	KAM R1	81.2
DS-DE 35-RL/OA	35	L 160	50	50	50	59	38	52.5	51	12.5	G 1 1/4"A	500	37.69x3.53	KAM R1 1/4	126.0
DS-DE 42-RL/OA	42	L 160	55	50	60	61	38	54.5	56	12.5	G 1 1/2"A	600	44.04x3.53	KAM R1 1/2	142.8
DS-DE 6-RS/OA	6	S 315	19	14	17	30	15	25.0	20	7.0	G 1/4"A	50	10.77x2.62	KAM R1/4	10.9
DS-DE 8-RS/OA	8	S 315	19	19	19	32	17	27.0	20	7.0	G 1/4"A	50	10.77x2.62	KAM R1/4	15.3
DS-DE 10-RS/OA	10	S 250	22	19	22	34	18	30.0	23	7.0	G 3/8"A	80	13.94x2.62	KAM R3/8	19.1
DS-DE 12-RS/OA	12	S 250	22	22	24	38	22	30.0	23	7.0	G 3/8"A	80	13.94x2.62	KAM R3/8	23.8
DS-DE 16-RS/OA	16	S 250	27	27	30	43	25	38.5	28	10.5	G 1/2"A	105	17x3	KAM R1/2	43.2
DS-DE 20-RS/OA	20	S 250	36	30	36	49	28	38.5	33	10.5	G 3/4"A	220	23.6x2.9	KAM R3/4	75.7
DS-DE 25-RS/OA	25	S 250	41	36	46	54	30	46.5	41	12.5	G 1"A	370	29.74x3.53	KAM R1	104.2
DS-DE 30-RS/OA	30	S 160	50	50	50	62	36	51.5	51	12.5	G 1 1/4"A	500	37.69x3.53	KAM R1 1/4	143.6
DS-DE 38-RS/OA	38	S 160	55	50	60	65	34	57.5	56	12.5	G 1 1/2"A	600	44.04x3.53	KAM R1 1/2	165.6

* Recommended tightening torques for stud threads G, with mating material steel

Please see "Engineering and technical data - Selecting the correct tube fitting" for more information on pressure.

COUPLINGS

ADJUSTABLE LOCKNUT COUPLING

DE ADJUSTABLE LOCKNUT RUN TEE

DE ADJUSTABLE LOCKNUT RUN TEE METRIC RR

Metric parallel for small or wide spot face.

Retaining ring and O-ring NBR (e.g. Perbunan), FPM (e.g. Viton) upon request.

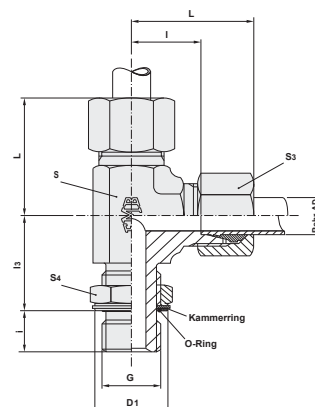

description	pipe OD	PN series	S ₄	S	S ₃	L	l	l ₃	D ₁	i	G	MA* Nm	O-Ring	Support ring small	kg / 100 pcs
DS-DE 6-ML/OA	6	L 315	14	14	14	29	14	21.5	15	5.5	M 10x1	18	8x1.88	KAM M10x1	9.3
DS-DE 8-ML/OA	8	L 315	17	14	17	31	16	23.5	18	8.5	M 12x1.5	35	9.3x2.2	KAM M12x1.5	10.3
DS-DE 10-ML/OA	10	L 315	19	19	19	32	17	26.5	20	8.5	M 14x1.5	55	11.3x2.2	KAM M14x1.5	17.5
DS-DE 12-ML/OA	12	L 315	22	19	22	34	19	27.5	23	8.5	M 16x1.5	80	13.3x2.2	KAM M16x1.5	19.1
DS-DE 15-ML/OA	15	L 315	24	22	27	36	21	32.0	25	9.0	M 18x1.5	105	15.54x2.62	KAM M18x1.5	33.1
DS-DE 18-ML/OA	18	L 250	27	27	32	40	24	35.5	28	9.5	M 22x1.5	125	19.2x3	KAM M22x1.5	42.3
DS-DE 22-ML/OA	22	L 160	32	30	36	44	28	37.5	33	11.5	M 27x2	220	23.47x2.95	KAM M27x2	73.7
DS-DE 28-ML/OA	28	L 160	41	36	41	47	31	40.5	41	11.5	M 33x2	370	29.2x3	KAM M33x2	77.7
DS-DE 35-ML/OA	35	L 160	50	50	50	59	38	50.5	51	11.5	M 42x2	500	37.69x3.53	KAM M42x2	126.0
DS-DE 42-ML/OA	42	L 160	55	50	60	61	38	51.5	56	13.5	M 48x2	600	43.69x3	KAM M48x2	142.8
DS-DE 6-MS/OA	6	S 315	17	14	17	30	15	23.5	18	8.5	M 12x1.5	35	9.3x2.2	KAM M12x1.5	10.6
DS-DE 8-MS/OA	8	S 315	19	19	19	32	17	27.5	20	8.5	M 14x1.5	55	11.3x2.2	KAM M14x1.5	17.7
DS-DE 10-MS/OA	10	S 315	22	19	22	34	18	28.5	23	9.5	M 16x1.5	80	13.3x2.2	KAM M16x1.5	19.5
DS-DE 12-MS/OA	12	S 315	24	22	24	38	22	33.0	25	10.0	M 18x1.5	105	15.54x2.62	KAM M18x1.5	31.3
DS-DE 16-MS/OA	16	S 250	27	27	30	43	25	37.5	28	11.5	M 22x1.5	125	19.2x3	KAM M22x1.5	42.7
DS-DE 20-MS/OA	20	S 250	32	30	36	49	28	41.5	33	13.5	M 27x2	220	23.47x2.95	KAM M27x2	77.5
DS-DE 25-MS/OA	25	S 160	41	36	46	54	30	46.5	41	13.5	M 33x2	370	29.2x3	KAM M33x2	100.7
DS-DE 30-MS/OA	30	S 160	50	50	50	62	36	53.5	51	14.5	M 42x2	500	37.69x3.53	KAM M42x2	143.6
DS-DE 38-MS/OA	38	S 160	55	50	60	65	34	56.5	56	16.5	M 48x2	600	43.69x3	KAM M48x2	165.6

* Recommended tightening torques for stud threads G, with mating material steel

Please see "Engineering and technical data - Selecting the correct tube fitting" for more information on pressure.

THE WORLD OF TUBE FITTINGS
INTEGRATED FLUID POWER SOLUTIONS



PIPE CONNECTIONS



PIPE CONNECTIONS GAUGE COUPLINGS

THE WORLD OF TUBE FITTINGS

O GAUGE COUPLING BSP

BSP parallel.

With sealing ring DK1.

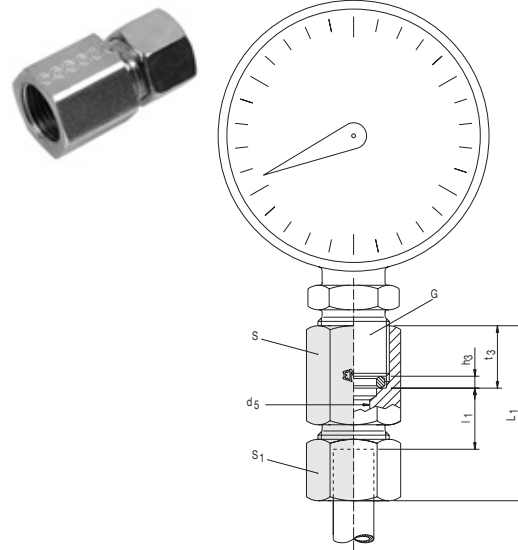

description	pipe OD	PN series	S ₁	S	L ₁	l ₁	G	d ₅	t ₃	h ₃	kg / 100 pcs
DS-O 6-L	6	L 400 (1700)	14	19	37	7.5	G 1/4"	2.5	14.5	4.5	4.6
DS-O 8-L	8	L 400 (1700)	17	19	37	7.5	G 1/4"	5.5	14.5	4.5	5.3
DS-O 10-L	10	L 400 (1700)	19	19	38	8.5	G 1/4"	5.5	14.5	4.5	6.2
DS-O 12-L	12	L 400 (1700)	22	19	38	8.5	G 1/4"	5.5	14.5	4.5	7.0
DS-O 6-S	6	S 630 (2700)	17	27	46	11.0	G 1/2"	3.5	20.0	5.0	10.5
DS-O 8-S	8	S 630 (2700)	19	27	46	11.0	G 1/2"	3.5	20.0	5.0	10.7
DS-O 10-S	10	S 630 (2700)	22	27	47	10.5	G 1/2"	7.0	20.0	5.0	12.5
DS-O 12-S	12	S 630 (2700)	24	27	47	10.5	G 1/2"	7.0	20.0	5.0	13.4

L₁ = approximate length, with nut tightened

Please see "Engineering and technical data - Selecting the correct tube fitting" for more information on pressure.

PIPE CONNECTIONS GAUGE COUPLINGS

VODKO GAUGE COUPLING TAPER

With taper, sealing ring DKI and O-ring according to DIN 3865.

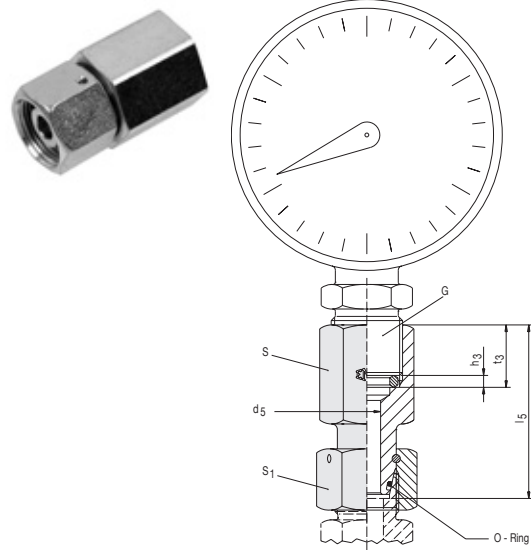

description	pipe OD	PN series	l_5	d_5	t_3	S	S_1	h_3	G	O-ring	kg / 100 pcs
VODKO 6-L	6	L 400 (1700)	38.0	2.5	14.5	19	17	4.5	G 1/4"	4x1.5	4.6
VODKO 8-L	8	L 400 (1700)	38.0	4.0	14.5	19	17	4.5	G 1/4"	6x1.5	5.3
VODKO 10-L	10	L 400 (1700)	39.5	5.5	14.5	19	19	4.5	G 1/4"	7.5x1.5	6.2
VODKO 12-L	12	L 400 (1700)	40.5	5.5	14.5	19	22	4.5	G 1/4"	9x1.5	7.0
VODKO 6-S	6	S 630 (2700)	45.0	2.5	20.0	27	17	5.0	G 1/2"	4x1.5	10.5
VODKO 8-S	8	S 630 (2700)	45.0	4.0	20.0	27	19	5.0	G 1/2"	6x1.5	10.7
VODKO 10-S	10	S 630 (2700)	47.0	6.0	20.0	27	22	5.0	G 1/2"	7.5x1.5	12.5
VODKO 12-S	12	S 630 (2700)	47.5	7.0	20.0	27	24	5.0	G 1/2"	9x1.5	13.4

Please see "Engineering and technical data - Selecting the correct tube fitting" for more information on pressure.

PIPE CONNECTIONS FEMALE STUD COUPLINGS

THE WORLD OF TUBE FITTINGS

AI FEMALE STUD COUPLING BSP

BSP parallel.

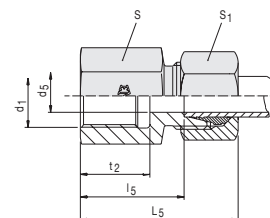

description	pipe OD	PB series	l_5	d_5	L_5	S	S_1	t_2	G	kg / 100 pcs
DS-AI 6-L/R 1/8"	6	L 315 (863)	19.0	4	34	14	14	12.0	G 1/8"	2.5
DS-AI 8-L/R 1/4"	8	L 315 (863)	24.0	6	39	19	17	17.0	G 1/4"	4.5
DS-AI 10-L/R 1/4"	10	L 315 (863)	25.0	8	40	19	19	17.0	G 1/4"	5.5
DS-AI 12-L/R 3/8"	12	L 315 (863)	26.0	10	41	24	22	17.0	G 3/8"	9.0
DS-AI 15-L/R 1/2"	15	L 315 (863)	31.0	12	46	27	27	20.0	G 1/2"	13.0
DS-AI 18-L/R 1/2"	18	L 315 (863)	30.5	15	47	27	32	20.0	G 1/2"	15.0
DS-AI 22-L/R 3/4"	22	L 160 (400)	35.5	19	52	36	36	22.0	G 3/4"	25.5
DS-AI 28-L/R 1"	28	L 160 (400)	38.0	24	55	41	41	24.5	G 1"	30.0
DS-AI 35-L/R 1 1/4"	35	L 160 (400)	41.0	30	63	55	50	26.5	G 1 1/4"	42.0
DS-AI 42-L/R 1 1/2"	42	L 160 (400)	42.5	36	65	60	60	28.5	G 1 1/2"	60.5
DS-AI 6-S/R 1/4"	6	S 630 (1575)	26.0	4	41	19	17	17.0	G 1/4"	6.0
DS-AI 8-S/R 1/4"	8	S 630 (1575)	26.0	5	41	19	19	17.0	G 1/4"	6.5
DS-AI 10-S/R 3/8"	10	S 630 (1575)	26.5	7	43	24	22	17.0	G 3/8"	9.0
DS-AI 12-S/R 3/8"	12	S 630 (1575)	26.5	8	43	24	24	17.0	G 3/8"	10.5
DS-AI 14-S/R 1/2"	14	S 630 (1575)	32.0	10	50	27	27	20.0	G 1/2"	13.0
DS-AI 16-S/R 1/2"	16	S 630 (1575)	31.5	12	50	27	30	20.0	G 1/2"	16.0
DS-AI 20-S/R 3/4"	20	S 400 (1000)	34.5	16	56	36	36	22.0	G 3/4"	26.0
DS-AI 25-S/R 1"	25	S 400 (1000)	37.5	20	62	41	46	24.5	G 1"	40.0
DS-AI 30-S/R 1 1/4"	30	S 400 (1000)	42.0	25	69	55	50	26.5	G 1 1/4"	72.0
DS-AI 38-S/R 1 1/2"	38	S 400 (1000)	43.5	32	74	60	60	28.5	G 1 1/2"	85.5

L_5 = approximate length, with nut tightened

Please see "Engineering and technical data - Selecting the correct tube fitting" for more information on pressure.

PIPE CONNECTIONS

FEMALE STUD COUPLINGS

AI FEMALE STUD COUPLING METRIC

Metric parallel.

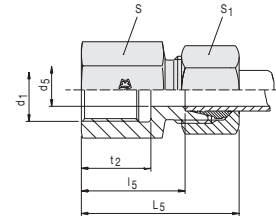

description	pipe OD	PB series	l_5	d_5	L_5	S	S_1	t_2	G	kg / 100 pcs
DS-AI 6-L/M 10x1	6	L 315 [863]	19.5	4	34	14	14	12.5	M 10x1	2.9
DS-AI 8-L/M 12x1.5	8	L 315 [863]	24.0	6	39	17	17	17.0	M 12x1.5	4.7
DS-AI 10-L/M 14x1.5	10	L 315 [863]	25.0	8	40	19	19	17.0	M 14x1.5	5.9
DS-AI 12-L/M 16x1.5	12	L 315 [863]	26.0	10	41	22	22	17.0	M 16x1.5	7.9
DS-AI 15-L/M 18x1.5	15	L 315 [863]	28.0	12	43	24	27	17.0	M 18x1.5	11.2
DS-AI 18-L/M 22x1.5	18	L 315 [863]	29.5	15	46	30	32	19.0	M 22x1.5	17.4
DS-AI 22-L/M 26x1.5	22	L 160 [400]	34.5	19	51	32	36	21.0	M 26x1.5	20.9
DS-AI 28-L/M 33x2	28	L 160 [400]	37.5	24	54	41	41	24.0	M 33x2	31.2
DS-AI 35-L/M 42x2	35	L 160 [400]	40.5	30	62	55	50	26.0	M 42x2	57.9
DS-AI 42-L/M 48x2	42	L 160 [400]	42.0	36	65	60	60	28.0	M 48x2	76.0
DS-AI 6-S/M 12x1.5	6	S 630 [1575]	26.0	4	41	17	17	17.0	M 12x1.5	5.3
DS-AI 8-S/M 14x1.5	8	S 630 [1575]	26.0	5	41	19	19	17.0	M 14x1.5	6.4
DS-AI 10-S/M 16x1.5	10	S 630 [1575]	26.5	7	43	22	22	17.0	M 16x1.5	9.0
DS-AI 12-S/M 18x1.5	12	S 630 [1575]	27.5	8	44	22	24	17.0	M 18x1.5	10.6
DS-AI 14-S/M 20x1.5	14	S 630 [1575]	31.0	10	49	27	27	19.0	M 20x1.5	14.9
DS-AI 16-S/M 22x1.5	16	S 630 [1575]	30.5	12	49	27	30	19.0	M 22x1.5	18.3
DS-AI 20-S/M 27x2	20	S 400 [1000]	34.5	16	56	36	36	22.0	M 27x2	29.9
DS-AI 25-S/M 33x2	25	S 400 [1000]	37.0	20	61	41	46	24.0	M 33x2	45.5
DS-AI 30-S/M 42x2	30	S 400 [1000]	41.5	25	68	55	50	26.0	M 42x2	73.0
DS-AI 38-S/M 48x2	38	S 400 [1000]	43.0	32	74	60	60	28.0	M 48x2	93.8

L_5 = approximate length, with nut tightened

Please see "Engineering and technical data - Selecting the correct tube fitting" for more information on pressure.

PIPE CONNECTIONS REDUCING ADAPTORS

THE WORLD OF TUBE FITTINGS

RI REDUCING ADAPTOR

BSP parallel.

Stud face form B.

Other sizes and threads upon request.

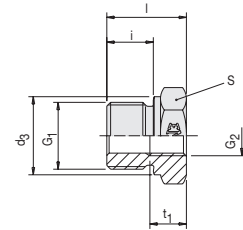

description G1-G2	PB	l	i	S	d ₃	t ₁	kg / 100 pcs
RI 3/8" - 1/8"	630	22.5	12	22	22	8.0	4.0
RI 1/2-1/4	400	24.0	14	27	26	8.0	6.0
RI 1/2-1/8	400	24.0	14	27	26	12.0	6.0
RI 3/4-1/4	400	26.0	16	32	32	12.0	9.5
RI 3/4-3/8	400	26.0	16	32	32	12.0	9.0
RI 1-1/4	400	29.0	18	41	39	12.0	20.0
RI 1-3/8	400	29.0	18	41	39	12.0	18.0
RI 1-1/2	400	29.0	18	41	39	14.0	16.0
RI 1 1/4-1/2	250	32.0	20	50	49	14.0	31.0
RI 1 1/4-3/4	250	32.0	20	50	49	16.0	27.0
RI 1 1/2-1/2	250	36.0	22	55	55	14.0	47.0
RI 1 1/2-3/4	250	36.0	22	55	55	16.0	43.0
RI 1 1/2-1	250	36.0	22	55	55	18.0	34.5
RI 1/8-1/4	630	31.0	8	19	14	17.0	3.6
RI 1/8-3/8	630	32.0	8	24	14	17.0	4.5
RI 1/4-1/8	630	28.0	12	19	18	12.0	3.6
RI 1/4-3/8	630	36.0	12	24	18	17.0	6.6
RI 1/4-1/2	630	40.0	12	30	18	20.0	8.5
RI 1/4-3/4	400	43.0	12	36	18	22.0	17.3
RI 3/8-1/4	630	36.0	12	22	22	17.0	3.0
RI 3/8-1/2	630	41.0	12	30	22	20.0	9.0
RI 3/8-3/4	400	44.0	12	36	22	22.0	17.5
RI 1/2-3/8	400	36.0	14	27	26	17.0	9.5
RI 1/2-3/4	400	46.0	14	36	26	22.0	18.0
RI 1/2-1	400	49.0	14	41	26	24.5	22.5
RI 1/2-1 1/4	250	53.0	14	55	26	26.5	47.0
RI 3/4-1/2	400	41.0	16	32	32	20.0	15.0
RI 3/4-1	400	51.0	16	41	32	24.5	23.5
RI 3/4-1 1/4	250	55.0	16	55	32	26.5	48.3
RI 3/4-1 1/2	250	57.0	16	60	32	28.5	54.5
RI 1-3/4	400	47.0	18	41	39	22.0	28.0
RI 1-1 1/4	250	57.0	18	55	39	26.5	51.0
RI 1-1 1/2	250	59.0	18	60	39	28.5	56.5
RI 1 1/4-1	250	52.0	20	50	49	24.5	45.5
RI 1 1/4-1 1/2	250	60.0	20	60	49	28.5	58.0
RI 1 1/2-1 1/4	250	58.0	22	55	55	26.5	53.0

Please see "Engineering and technical data - Selecting the correct tube fitting" for
- reducing example.
- more information on pressure.

PIPE CONNECTIONS REDUCING ADAPTORS

RI REDUCING ADAPTOR WITH CAPTIVE SEAL

BSP parallel.

Captive seal O-ring NBR (e.g. Perbunan),
FPM (e.g. Viton) upon request.

Other sizes and threads upon request.

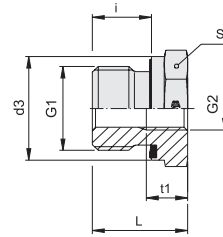

description G1-G2	PB	l	i	S	d ₃	t ₁	kg / 100 pcs
RI 3/8"WD - 1/8"	630	22.5	12	22	22	8.0	3.9
RI 1/2"WD - 1/8"	630	24.0	14	27	27	8.0	6.6
RI 1/2"WD - 1/4"	630	24.0	14	27	27	12.0	5.6
RI 3/4"WD - 1/4"	400	26.0	16	32	32	12.0	10.3
RI 3/4"WD - 3/8"	400	26.0	16	32	32	12.0	8.7
RI 1"WD - 1/4"	400	29.0	18	41	40	12.0	19.5
RI 1"WD - 3/8"	400	29.0	18	41	40	12.0	17.9
RI 1"WD - 1/2"	400	29.0	18	41	40	14.0	15.7
RI 1 1/4"WD - 1/2"	400	32.0	20	50	50	14.0	30.8
RI 1 1/4"WD - 3/4"	400	32.0	20	50	50	16.0	26.6
RI 1 1/2"WD - 1/2"	315	36.0	22	55	55	14.0	47.0
RI 1 1/2"WD - 3/4"	315	36.0	22	55	55	16.0	40.2
RI 1 1/2"WD - 1"	315	36.0	22	55	55	18.0	33.7
RI 1/8"WD - 1/4"	630	31.0	8	19	14	17.0	3.9
RI 1/8"WD - 3/8"	630	32.0	8	24	14	17.0	6.3
RI 1/4"WD - 1/8"	630	29.0	12	19	19	12.0	3.8
RI 1/4"WD - 3/8"	630	36.0	12	24	19	17.0	6.7
RI 1/4"WD - 1/2"	630	40.0	12	30	19	20.0	11.6
RI 1/4"WD - 3/4"	630	43.0	12	36	19	22.0	17.0
RI 3/8"WD - 1/4"	630	36.0	12	22	22	17.0	6.8
RI 3/8"WD - 1/2"	630	41.0	12	30	22	20.0	14.3
RI 3/8"WD - 3/4"	400	44.0	12	36	22	22.0	18.3
RI 1/2"WD - 3/8"	630	37.0	14	27	27	17.0	9.1
RI 1/2"WD - 3/4"	400	46.0	14	36	27	22.0	18.2
RI 1/2"WD - 1"	400	49.0	14	41	27	24.5	22.1
RI 1/2"WD - 1 1/4"	400	53.0	14	55	27	26.5	48.2
RI 3/4"WD - 1/2"	400	43.0	16	32	32	20.0	14.3
RI 3/4"WD - 1"	400	51.0	16	41	32	24.5	23.5
RI 3/4"WD - 1 1/4"	400	55.0	16	55	32	26.5	48.1
RI 3/4"WD - 1 1/2"	315	57.0	16	60	32	28.5	56.0
RI 1"WD - 3/4"	400	49.0	18	41	40	22.0	26.8
RI 1"WD - 1 1/4"	400	57.0	18	55	40	26.5	50.3
RI 1"WD - 1 1/2"	315	59.0	18	60	40	28.5	58.5
RI 1 1/4"WD - 1"	400	53.0	20	50	50	24.5	45.8
RI 1 1/4"WD - 1 1/2"	315	60.0	20	60	50	28.5	61.6
RI 1 1/2"WD - 1 1/4"	315	58.0	22	55	55	26.5	54.2

Please see "Engineering and technical data - Selecting the correct tube fitting" for
- reducing example.
- more information on pressure.

PIPE CONNECTIONS REDUCING CONNECTIONS

THE WORLD OF TUBE FITTINGS

RL REDUCING CONNECTION

These parts are ready mounted;
not pre-assembled.

After screwing on by hand, tighten with a spanner
until tight, and then apply final 30 ° turn.

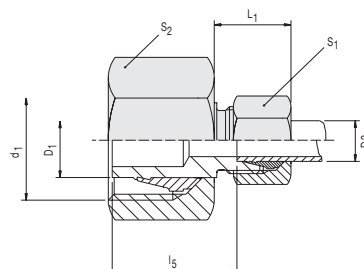

description	pipe OD1	pipe OD2	PN series	L ₁	l ₅	S ₁	S ₂	d ₁	kg / 100 pcs
DS-RL 8/6	8	6	L 500 (2200)	24	23.5	14	17	M 14x1.5	4.0
DS-RL 10/6	10	6	L 500 (2200)	24	23.5	14	19	M 16x1.5	4.7
DS-RL 10/8	10	8	L 500 (2200)	24	23.5	17	19	M 16x1.5	5.2
DS-RL 12/6	12	6	L 400 (1700)	24	23.5	14	22	M 18x1.5	5.9
DS-RL 12/8	12	8	L 400 (1700)	24	23.5	17	22	M 18x1.5	6.3
DS-RL 12/10	12	10	L 400 (1700)	25	24.5	19	22	M 18x1.5	6.9
DS-RL 15/6	15	6	L 400 (1700)	23	23.5	14	27	M 22x1.5	8.2
DS-RL 15/8	15	8	L 400 (1700)	23	23.5	17	27	M 22x1.5	8.9
DS-RL 15/10	15	10	L 400 (1700)	24	24.5	19	27	M 22x1.5	9.3
DS-RL 15/12	15	12	L 400 (1700)	24	24.5	22	27	M 22x1.5	10.0
DS-RL 18/6	18	6	L 400 (1700)	23	24.5	14	32	M 26x1.5	10.8
DS-RL 18/8	18	8	L 400 (1700)	23	24.5	17	32	M 26x1.5	11.0
DS-RL 18/10	18	10	L 400 (1700)	24	25.5	19	32	M 26x1.5	11.7
DS-RL 18/12	18	12	L 400 (1700)	24	25.5	22	32	M 26x1.5	12.5
DS-RL 18/15	18	15	L 400 (1700)	26	26.5	27	32	M 26x1.5	14.9
DS-RL 22/6	22	6	L 250 (1100)	24	25.5	14	36	M 30x2	14.1
DS-RL 22/8	22	8	L 250 (1100)	24	25.5	17	36	M 30x2	14.9
DS-RL 22/10	22	10	L 250 (1100)	25	26.5	19	36	M 30x2	15.1
DS-RL 22/12	22	12	L 250 (1100)	25	26.5	22	36	M 30x2	16.0
DS-RL 22/15	22	15	L 250 (1100)	27	27.5	27	36	M 30x2	18.0
DS-RL 22/18	22	18	L 250 (1100)	27	27.0	32	36	M 30x2	19.8
DS-RL 28/6	28	6	L 250 (1100)	25	26.5	14	41	M 36x2	18.5
DS-RL 28/8	28	8	L 250 (1100)	25	26.5	17	41	M 36x2	19.3
DS-RL 28/10	28	10	L 250 (1100)	26	27.5	19	41	M 36x2	20.0
DS-RL 28/12	28	12	L 250 (1100)	26	27.5	22	41	M 36x2	20.5
DS-RL 28/15	28	15	L 250 (1100)	27	28.5	27	41	M 36x2	22.5
DS-RL 28/18	28	18	L 250 (1100)	28	28.0	32	41	M 36x2	24.5
DS-RL 28/22	28	22	L 250 (1100)	30	30.0	36	41	M 36x2	26.8
DS-RL 35/6	35	6	L 250 (1100)	25	31.5	14	50	M 45x2	30.8
DS-RL 35/8	35	8	L 250 (1100)	25	31.5	17	50	M 45x2	31.2
DS-RL 35/10	35	10	L 250 (1100)	26	32.5	19	50	M 45x2	32.0
DS-RL 35/12	35	12	L 250 (1100)	26	32.5	22	50	M 45x2	32.0
DS-RL 35/15	35	15	L 250 (1100)	27	33.5	27	50	M 45x2	34.8
DS-RL 35/18	35	18	L 250 (1100)	28	33.0	32	50	M 45x2	36.2
DS-RL 35/22	35	22	L 250 (1100)	30	35.0	36	50	M 45x2	37.8
DS-RL 35/28	35	28	L 250 (1100)	30	35.0	41	50	M 45x2	39.5
DS-RL 42/6	42	6	L 250 (1100)	24	32.5	14	60	M 52x2	44.0
DS-RL 42/8	42	8	L 250 (1100)	24	32.5	17	60	M 52x2	45.0
DS-RL 42/10	42	10	L 250 (1100)	26	33.5	19	60	M 52x2	45.0
DS-RL 42/12	42	12	L 250 (1100)	26	33.5	22	60	M 52x2	45.9
DS-RL 42/15	42	15	L 250 (1100)	27	34.5	27	60	M 52x2	47.0
DS-RL 42/18	42	18	L 250 (1100)	28	34.0	32	60	M 52x2	48.9
DS-RL 42/22	42	22	L 250 (1100)	30	36.0	36	60	M 52x2	51.0
DS-RL 42/28	42	28	L 250 (1100)	30	36.0	41	60	M 52x2	53.0
DS-RL 42/35	42	35	L 250 (1100)	34	34.0	50	60	M 52x2	58.3

L₁ = approximate length. with nut tightened

Please see "Engineering and technical data - Selecting the correct tube fitting" for
- reducing example.

- more information on pressure.

PIPE CONNECTIONS

REDUCING CONNECTIONS

RS REDUCING CONNECTION

These parts are ready mounted;
not pre-assembled.

After screwing on by hand, tighten with a spanner
until tight, and then apply final 30 ° turn.

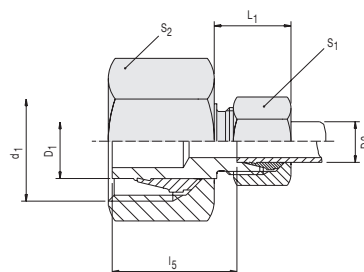

description	pipe OD1	pipe OD2	PN series	L ₁	l ₅	S ₁	S ₂	d ₁	kg / 100 pcs
DS-RS 8/6	8	6	S 800 (3400)	25	25.0	17	19	M 16x1.5	6.5
DS-RS 10/6	10	6	S 800 (3400)	25	26.0	17	22	M 18x1.5	7.0
DS-RS 10/8	10	8	S 800 (3400)	25	26.0	19	22	M 18x1.5	7.5
DS-RS 12/6	12	6	S 630 (2700)	26	27.0	17	24	M 20x1.5	8.0
DS-RS 12/8	12	8	S 630 (2700)	26	27.0	19	24	M 20x1.5	8.5
DS-RS 12/10	12	10	S 630 (2700)	27	26.5	22	24	M 20x1.5	9.9
DS-RS 14/6	14	6	S 630 (2700)	26	29.0	17	27	M 22x1.5	10.4
DS-RS 14/8	14	8	S 630 (2700)	26	29.0	19	27	M 22x1.5	10.9
DS-RS 14/10	14	10	S 630 (2700)	27	28.5	22	27	M 22x1.5	12.1
DS-RS 14/12	14	12	S 630 (2700)	27	28.5	24	27	M 22x1.5	12.6
DS-RS 16/6	16	6	S 630 (2700)	26	29.0	17	30	M 24x1.5	12.1
DS-RS 16/8	16	8	S 630 (2700)	26	29.0	19	30	M 24x1.5	12.6
DS-RS 16/10	16	10	S 630 (2700)	27	28.5	22	30	M 24x1.5	14.0
DS-RS 16/12	16	12	S 630 (2700)	27	28.5	24	30	M 24x1.5	14.5
DS-RS 16/14	16	14	S 630 (2700)	30	30.0	27	30	M 24x1.5	16.1
DS-RS 20/6	20	6	S 400 (1700)	27	34.0	17	36	M 30x2	17.8
DS-RS 20/8	20	8	S 400 (1700)	27	34.0	19	36	M 30x2	18.4
DS-RS 20/10	20	10	S 400 (1700)	28	33.5	22	36	M 30x2	19.5
DS-RS 20/12	20	12	S 400 (1700)	28	33.5	24	36	M 30x2	20.4
DS-RS 20/14	20	14	S 400 (1700)	31	35.0	27	36	M 30x2	22.5
DS-RS 20/16	20	16	S 400 (1700)	31	34.5	30	36	M 30x2	23.9
DS-RS 25/6	25	6	S 400 (1700)	28	37.0	17	46	M 36x2	31.3
DS-RS 25/8	25	8	S 400 (1700)	28	37.0	19	46	M 36x2	31.9
DS-RS 25/10	25	10	S 400 (1700)	29	36.5	22	46	M 36x2	33.0
DS-RS 25/12	25	12	S 400 (1700)	29	36.5	24	46	M 36x2	33.6
DS-RS 25/14	25	14	S 400 (1700)	31	37.0	27	46	M 36x2	36.0
DS-RS 25/16	25	16	S 400 (1700)	31	36.5	30	46	M 36x2	36.8
DS-RS 25/20	25	20	S 400 (1700)	35	37.5	36	46	M 36x2	40.8
DS-RS 30/6	30	6	S 400 (1700)	27	39.0	17	50	M 42x2	37.7
DS-RS 30/8	30	8	S 400 (1700)	27	39.0	19	50	M 42x2	38.7
DS-RS 30/10	30	10	S 400 (1700)	28	38.5	22	50	M 42x2	39.8
DS-RS 30/12	30	12	S 400 (1700)	28	38.5	24	50	M 42x2	40.4
DS-RS 30/14	30	14	S 400 (1700)	31	40.0	27	50	M 42x2	42.3
DS-RS 30/16	30	16	S 400 (1700)	31	39.5	30	50	M 42x2	43.4
DS-RS 30/20	30	20	S 400 (1700)	35	39.5	36	50	M 42x2	47.6
DS-RS 30/25	30	25	S 400 (1700)	38	40.0	46	50	M 42x2	59.1
DS-RS 38/6	38	6	S 400 (1700)	27	43.0	17	60	M 52x2	55.5
DS-RS 38/8	38	8	S 400 (1700)	27	43.0	19	60	M 52x2	55.7
DS-RS 38/10	38	10	S 400 (1700)	28	42.5	22	60	M 52x2	57.6
DS-RS 38/12	38	12	S 400 (1700)	28	42.5	24	60	M 52x2	58.0
DS-RS 38/14	38	14	S 400 (1700)	31	44.0	27	60	M 52x2	60.0
DS-RS 38/16	38	16	S 400 (1700)	31	43.5	30	60	M 52x2	61.3
DS-RS 38/20	38	20	S 400 (1700)	35	43.5	36	60	M 52x2	65.2
DS-RS 38/25	38	25	S 400 (1700)	38	44.0	46	60	M 52x2	76.9
DS-RS 38/30	38	30	S 400 (1700)	41	44.5	50	60	M 52x2	80.0

L₁ = approximate length. with nut tightened

Please see "Engineering and technical data - Selecting the correct tube fitting" for
- reducing example.

- more information on pressure.

PIPE CONNECTIONS REDUCING CONNECTIONS

THE WORLD OF TUBE FITTINGS

RLDKO REDUCING CONNECTION WITH TAPER

With taper and O-ring according to DIN 3865.

Supplied with fitted NBR O-ring (e.g. Perbunan),
FPM O-ring (e.g. Viton) upon request.

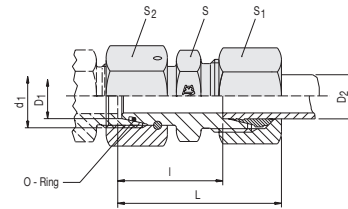

description	pipe OD1	pipe OD2	PN series	L	l	S	S ₁	S ₂	d ₁	O-ring	kg / 100 pcs
DS-RLDKO 8/6	8	6	L 500 (2200)	38.0	23.5	12	14	17	M 14x1.5	6x1.5	3.9
DS-RLDKO 10/6	10	6	L 500 (2200)	39.5	25.0	14	14	19	M 16x1.5	7.5x1.5	4.9
DS-RLDKO 10/8	10	8	L 500 (2200)	39.5	25.0	14	17	19	M 16x1.5	7.5x1.5	5.3
DS-RLDKO 12/6	12	6	L 400 (1700)	39.5	25.0	17	14	22	M 18x1.5	9x1.5	6.3
DS-RLDKO 12/8	12	8	L 400 (1700)	39.5	25.0	17	17	22	M 18x1.5	9x1.5	6.8
DS-RLDKO 12/10	12	10	L 400 (1700)	40.5	26.0	17	19	22	M 18x1.5	9x1.5	7.0
DS-RLDKO 15/6	15	6	L 400 (1700)	43.5	29.0	22	14	27	M 22x1.5	12x2	5.5
DS-RLDKO 15/8	15	8	L 400 (1700)	43.5	29.0	22	17	27	M 22x1.5	12x2	9.8
DS-RLDKO 15/10	15	10	L 400 (1700)	44.0	29.5	22	19	27	M 22x1.5	12x2	10.7
DS-RLDKO 15/12	15	12	L 400 (1700)	44.0	29.5	22	22	27	M 22x1.5	12x2	11.0
DS-RLDKO 18/6	18	6	L 400 (1700)	42.5	28.0	24	14	32	M 26x1.5	15x2	11.9
DS-RLDKO 18/8	18	8	L 400 (1700)	42.5	28.0	24	17	32	M 26x1.5	15x2	12.4
DS-RLDKO 18/10	18	10	L 400 (1700)	43.5	29.0	24	19	32	M 26x1.5	15x2	12.8
DS-RLDKO 18/12	18	12	L 400 (1700)	43.5	29.0	24	22	32	M 26x1.5	15x2	17.2
DS-RLDKO 18/15	18	15	L 400 (1700)	45.0	30.0	24	27	32	M 26x1.5	15x2	19.0
DS-RLDKO 22/6	22	6	L 250 (1100)	46.5	32.0	27	14	36	M 30x2	20x2	16.9
DS-RLDKO 22/8	22	8	L 250 (1100)	46.5	32.0	27	17	36	M 30x2	20x2	17.6
DS-RLDKO 22/10	22	10	L 250 (1100)	47.5	33.0	27	19	36	M 30x2	20x2	17.8
DS-RLDKO 22/12	22	12	L 250 (1100)	47.5	33.0	27	22	36	M 30x2	20x2	18.6
DS-RLDKO 22/15	22	15	L 250 (1100)	49.0	34.0	27	27	36	M 30x2	20x2	20.8
DS-RLDKO 22/18	22	18	L 250 (1100)	49.5	33.5	27	32	36	M 30x2	20x2	24.4
DS-RLDKO 28/6	28	6	L 250 (1100)	48.5	34.0	36	14	41	M 36x2	26x2	29.3
DS-RLDKO 28/8	28	8	L 250 (1100)	48.5	34.0	36	17	41	M 36x2	26x2	29.3
DS-RLDKO 28/10	28	10	L 250 (1100)	49.5	35.0	36	19	41	M 36x2	26x2	29.9
DS-RLDKO 28/12	28	12	L 250 (1100)	49.5	35.0	36	22	41	M 36x2	26x2	30.8
DS-RLDKO 28/15	28	15	L 250 (1100)	51.0	36.0	36	27	41	M 36x2	26x2	33.0
DS-RLDKO 28/18	28	18	L 250 (1100)	51.5	35.5	36	32	41	M 36x2	26x2	38.3
DS-RLDKO 28/22	28	22	L 250 (1100)	53.5	37.5	36	36	41	M 36x2	26x2	39.1
DS-RLDKO 35/6	35	6	L 250 (1100)	51.5	37.0	46	14	50	M 45x2	32x2.5	33.2
DS-RLDKO 35/8	35	8	L 250 (1100)	51.5	37.0	46	17	50	M 45x2	32x2.5	33.7
DS-RLDKO 35/10	35	10	L 250 (1100)	52.5	38.0	46	19	50	M 45x2	32x2.5	34.2
DS-RLDKO 35/12	35	12	L 250 (1100)	52.5	38.0	46	22	50	M 45x2	32x2.5	35.3
DS-RLDKO 35/15	35	15	L 250 (1100)	54.0	39.0	46	27	50	M 45x2	32x2.5	37.1
DS-RLDKO 35/18	35	18	L 250 (1100)	54.5	38.5	46	32	50	M 45x2	32x2.5	39.1
DS-RLDKO 35/22	35	22	L 250 (1100)	56.5	40.5	46	36	50	M 45x2	32x2.5	41.6
DS-RLDKO 35/28	35	28	L 250 (1100)	57.0	40.5	46	41	50	M 45x2	32x2.5	42.6
DS-RLDKO 42/6	42	6	L 250 (1100)	52.0	37.5	50	14	60	M 52x2	38x2.5	51.2
DS-RLDKO 42/8	42	8	L 250 (1100)	52.0	37.5	50	17	60	M 52x2	38x2.5	51.8
DS-RLDKO 42/10	42	10	L 250 (1100)	56.0	41.5	50	19	60	M 52x2	38x2.5	52.3
DS-RLDKO 42/12	42	12	L 250 (1100)	56.0	41.5	50	22	60	M 52x2	38x2.5	53.4
DS-RLDKO 42/15	42	15	L 250 (1100)	57.5	42.5	50	27	60	M 52x2	38x2.5	55.1
DS-RLDKO 42/18	42	18	L 250 (1100)	58.0	42.0	50	32	60	M 52x2	38x2.5	60.7
DS-RLDKO 42/22	42	22	L 250 (1100)	60.0	44.0	50	36	60	M 52x2	38x2.5	66.5
DS-RLDKO 42/28	42	28	L 250 (1100)	60.5	44.0	50	41	60	M 52x2	38x2.5	68.0
DS-RLDKO 42/35	42	35	L 250 (1100)	64.5	43.0	50	50	60	M 52x2	38x2.5	69.5

L = approximate length, with nut tightened

Please see "Engineering and technical data - Selecting the correct tube fitting" for
- reducing example.

- more information on pressure.

PIPE CONNECTIONS REDUCING CONNECTIONS

RSDKO REDUCING CONNECTION WITH TAPER

With taper and O-ring according to DIN 3865.

Supplied with fitted NBR O-ring (e.g. Perbunan),
FPM O-ring (e.g. Viton) upon request.

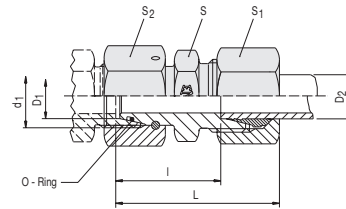

description	pipe OD1	pipe OD2	PN series	L	l	S	S ₁	S ₂	d ₁	O-ring	kg / 100 pcs
DS-RSDKO 8/6	8	6	S 800 (3400)	41.5	27.0	14	17	19	M 16x1.5	6x1.5	3.4
DS-RSDKO 10/6	10	6	S 800 (3400)	42.0	27.5	17	17	22	M 18x1.5	7.5x1.5	7.2
DS-RSDKO 10/8	10	8	S 800 (3400)	42.0	27.5	17	19	22	M 18x1.5	7.5x1.5	7.8
DS-RSDKO 12/6	12	6	S 630 (2700)	43.5	29.0	19	17	24	M 20x1.5	9x1.5	8.3
DS-RSDKO 12/8	12	8	S 630 (2700)	43.5	29.0	19	19	24	M 20x1.5	9x1.5	9.3
DS-RSDKO 12/10	12	10	S 630 (2700)	45.5	29.5	19	22	24	M 20x1.5	9x1.5	10.7
DS-RSDKO 14/6	14	6	S 630 (2700)	48.0	33.5	22	17	27	M 22x1.5	10x2	9.2
DS-RSDKO 14/8	14	8	S 630 (2700)	48.0	33.5	22	19	27	M 22x1.5	10x2	9.9
DS-RSDKO 14/10	14	10	S 630 (2700)	49.0	33.0	22	22	27	M 22x1.5	10x2	11.0
DS-RSDKO 14/12	14	12	S 630 (2700)	49.0	33.0	22	24	27	M 22x1.5	10x2	11.9
DS-RSDKO 16/6	16	6	S 630 (2700)	46.5	32.0	22	17	30	M 24x1.5	12x2	12.7
DS-RSDKO 16/8	16	8	S 630 (2700)	46.5	32.0	22	19	30	M 24x1.5	12x2	14.8
DS-RSDKO 16/10	16	10	S 630 (2700)	47.5	31.5	22	22	30	M 24x1.5	12x2	14.8
DS-RSDKO 16/12	16	12	S 630 (2700)	47.5	31.5	22	24	30	M 24x1.5	12x2	15.5
DS-RSDKO 16/14	16	14	S 630 (2700)	50.5	33.0	24	27	30	M 24x1.5	12x2	16.3
DS-RSDKO 20/6	20	6	S 400 (1700)	50.5	36.0	27	17	36	M 30x2	16.3x2.4	18.9
DS-RSDKO 20/8	20	8	S 400 (1700)	50.5	36.0	27	19	36	M 30x2	16.3x2.4	20.5
DS-RSDKO 20/10	20	10	S 400 (1700)	51.5	35.5	27	22	36	M 30x2	16.3x2.4	20.6
DS-RSDKO 20/12	20	12	S 400 (1700)	51.5	35.5	27	24	36	M 30x2	16.3x2.4	21.3
DS-RSDKO 20/14	20	14	S 400 (1700)	54.5	37.0	27	27	36	M 30x2	16.3x2.4	23.2
DS-RSDKO 20/16	20	16	S 400 (1700)	54.5	36.5	27	30	36	M 30x2	16.3x2.4	25.9
DS-RSDKO 25/6	25	6	S 400 (1700)	53.0	38.5	36	17	46	M 36x2	20.3x2.4	30.8
DS-RSDKO 25/8	25	8	S 400 (1700)	53.0	38.5	36	19	46	M 36x2	20.3x2.4	31.9
DS-RSDKO 25/10	25	10	S 400 (1700)	54.0	38.0	36	22	46	M 36x2	20.3x2.4	33.2
DS-RSDKO 25/12	25	12	S 400 (1700)	54.0	38.0	36	24	46	M 36x2	20.3x2.4	33.4
DS-RSDKO 25/14	25	14	S 400 (1700)	57.0	39.5	36	27	46	M 36x2	20.3x2.4	35.1
DS-RSDKO 25/16	25	16	S 400 (1700)	57.0	39.0	36	30	46	M 36x2	20.3x2.4	37.3
DS-RSDKO 25/20	25	20	S 400 (1700)	60.5	39.0	36	36	46	M 36x2	20.3x2.4	43.6
DS-RSDKO 30/6	30	6	S 400 (1700)	58.5	44.0	41	17	50	M 42x2	25.3x2.4	42.9
DS-RSDKO 30/8	30	8	S 400 (1700)	58.5	44.0	41	19	50	M 42x2	25.3x2.4	43.1
DS-RSDKO 30/10	30	10	S 400 (1700)	59.5	43.5	41	22	50	M 42x2	25.3x2.4	43.6
DS-RSDKO 30/12	30	12	S 400 (1700)	59.5	43.5	41	24	50	M 42x2	25.3x2.4	44.3
DS-RSDKO 30/14	30	14	S 400 (1700)	62.5	45.0	41	27	50	M 42x2	25.3x2.4	46.1
DS-RSDKO 30/16	30	16	S 400 (1700)	62.5	44.5	41	30	50	M 42x2	25.3x2.4	48.7
DS-RSDKO 30/20	30	20	S 400 (1700)	66.0	44.5	41	36	50	M 42x2	25.3x2.4	53.6
DS-RSDKO 30/25	30	25	S 400 (1700)	69.0	45.0	41	46	50	M 42x2	25.3x2.4	67.3
DS-RSDKO 38/6	38	6	S 400 (1700)	62.0	47.5	50	17	60	M 52x2	33.3x2.4	70.8
DS-RSDKO 38/8	38	8	S 400 (1700)	62.0	47.5	50	19	60	M 52x2	33.3x2.4	71.0
DS-RSDKO 38/10	38	10	S 400 (1700)	63.0	47.0	50	22	60	M 52x2	33.3x2.4	71.4
DS-RSDKO 38/12	38	12	S 400 (1700)	63.0	47.0	50	24	60	M 52x2	33.3x2.4	72.0
DS-RSDKO 38/14	38	14	S 400 (1700)	66.0	48.5	50	27	60	M 52x2	33.3x2.4	74.3
DS-RSDKO 38/16	38	16	S 400 (1700)	66.0	48.0	50	30	60	M 52x2	33.3x2.4	77.0
DS-RSDKO 38/20	38	20	S 400 (1700)	69.5	48.0	50	36	60	M 52x2	33.3x2.4	81.2
DS-RSDKO 38/25	38	25	S 400 (1700)	72.5	48.5	50	46	60	M 52x2	33.3x2.4	85.0
DS-RSDKO 38/30	38	30	S 400 (1700)	75.5	49.0	50	50	60	M 52x2	33.3x2.4	87.8

L = approximate length, with nut tightened

Please see "Engineering and technical data - Selecting the correct tube fitting" for

- reducing example.

- more information on pressure.

THE WORLD OF TUBE FITTINGS
INTEGRATED FLUID POWER SOLUTIONS



VALVES



VALVES

NON-RETURN VALVES WITH CONE

THE WORLD OF TUBE FITTINGS

NON-RETURN VALVES – INTRODUCTION

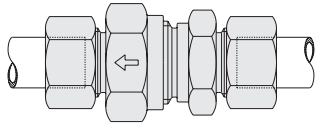

Order code RD

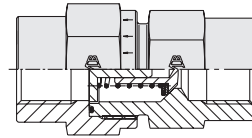

Order code RF

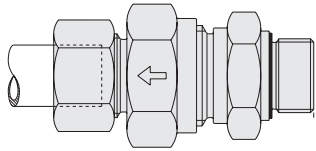

Order code RV

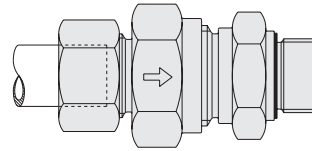

Order code RZ

SEALING

Guided cone with valve lift stop.

No diminished cross section.

Max flow speed is about 8 m/sec.

OPENING PRESSURE

1 bar. Further opening pressures upon request.

Tolerance opening pressure $\pm 20\%$.

BACK PRESSURE VALVES RV AND RZ

Sealing at screwed thread by Gates-EMB elastic seal (WD).

TEMPERATURE

Perbunan standard -35°C up to $+100^{\circ}\text{C}$.

Viton optional -40°C up to $+200^{\circ}\text{C}$.

MATERIAL

Drawn steel, galvanised surface.

Other materials upon request.

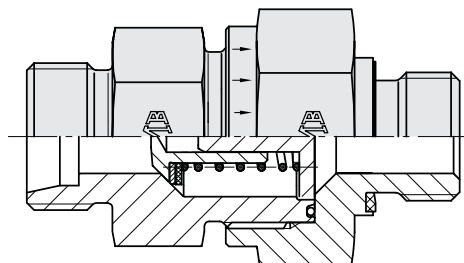

VALVES

NON-RETURN VALVES WITH CONE

RD NON-RETURN VALVES

Tube connection both ends.

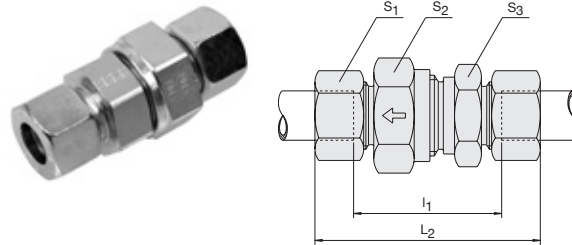

description		pipe OD	PB series	DN nominal size		S ₁	S ₂	S ₃	L ₁	I ₁	bore	kg / 100 pcs
DS-RD 6-L		6	L 250 (625)	4		14	17	17	58.0	29.0	3.5	6.5
DS-RD 8-L		8	L 250 (625)	6	1/8"	17	19	19	59.0	30.0	5.5	8.0
DS-RD 10-L		10	L 250 (625)	8	1/4"	19	24	22	69.5	40.5	7.5	14.0
DS-RD 12-L		12	L 250 (625)	10	3/8"	22	30	27	72.5	43.5	9.5	21.0
DS-RD 15-L		15	L 250 (625)	12	1/2"	27	32	27	77.5	47.5	11.5	25.0
DS-RD 18-L		18	L 160 (400)	16	1/2"	32	36	36	83.5	51.5	14.0	40.0
DS-RD 22-L		22	L 160 (400)	20	3/4"	36	46	41	93.5	61.5	18.0	61.0
DS-RD 28-L		28	L 100 (250)	25	1"	41	55	50	102.5	69.5	23.0	88.0
DS-RD 35-L		35	L 100 (250)	32	1 1/4"	50	60	60	117.5	74.5	29.0	130.0
DS-RD 42-L	1)	42	L 100 (250)	32	1 1/4"	60	70	65	119.0	74.0	29.0	200.0
DS-RD 6-S		6	S 400 (1000)	3		17	19	19	63.5	34.5	3.5	9.5
DS-RD 8-S		8	S 400 (1000)	4		19	19	19	63.5	34.5	3.5	11.0
DS-RD 10-S		10	S 400 (1000)	6	1/8"	22	24	22	72.5	40.5	5.5	18.0
DS-RD 12-S		12	S 400 (1000)	8	1/4"	24	27	24	74.5	42.5	7.5	21.5
DS-RD 14-S		14	S 400 (1000)	10	3/8"	27	32	27	82.5	47.5	9.5	30.0
DS-RD 16-S	1)	16	S 400 (1000)	12	1/2"	30	36	32	86.5	50.5	11.5	40.0
DS-RD 20-S	1)	20	S 400 (1000)	16	1/2"	36	46	41	97.5	54.5	15.0	69.0
DS-RD 25-S	1)	25	S 250 (625)	20	3/4"	46	50	46	106.5	58.5	19.0	103.5
DS-RD 30-S		30	S 250 (625)	25	1"	50	60	60	122.5	69.5	24.0	159.0
DS-RD 38-S	1)	38	S 250 (625)	32	1 1/4"	60	70	65	136.5	75.5	29.0	227.0

L₁ = approximate length with nut tightened

1) valve halves with O-ring sealing

Please see "Engineering and technical data - Selecting the correct tube fitting" for more information on pressure

VALVES NON-RETURN VALVES WITH CONE

THE WORLD OF TUBE FITTINGS

RV NON-RETURN VALVES BSP

Flow from male stud end.

BSP parallel.

Captive seal O-ring NBR (e.g. Perbunan),
FPM (e.g. Viton) upon request.

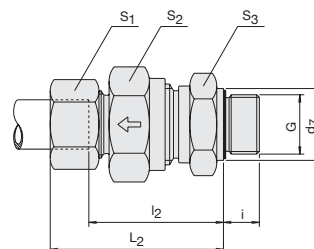

description	pipe OD	PB series	DN nominal size		S ₁	S ₂	S ₃	L ₂	l ₂	d ₇	i	bore	BSP thread	kg / 100 pcs
DS-RV 6-RL/WD	6	L 250 (625)	4		14	17	17	42.5	28.0	14	8	3.5	G 1/8" A	5.0
DS-RV 8-RL/WD	8	L 250 (625)	6	1/8"	17	19	19	44.5	30.0	19	12	5.5	G 1/4" A	7.2
DS-RV 10-RL/WD	10	L 250 (625)	8	1/4"	19	24	22	53.0	38.5	19	12	7.5	G 1/4" A	9.0
DS-RV 12-RL/WD	12	L 250 (625)	10	3/8"	22	30	27	57.0	42.5	22	12	9.5	G 3/8" A	18.5
DS-RV 15-RL/WD	15	L 250 (625)	12	1/2"	27	32	27	60.5	45.5	27	14	11.5	G 1/2" A	22.5
DS-RV 18-RL/WD	18	L 160 (400)	16	1/2"	32	36	36	66.0	50.0	27	14	14.0	G 1/2" A	33.5
DS-RV 22-RL/WD	22	L 160 (400)	20	3/4"	36	46	41	71.0	55.0	32	16	18.0	G 3/4" A	50.0
DS-RV 28-RL/WD	28	L 100 (250)	25	1"	41	55	50	79.5	63.0	40	18	23.0	G 1" A	78.5
DS-RV 35-RL/WD	35	L 100 (250)	32	1 1/4"	50	60	60	90.5	69.0	50	20	29.0	G 1 1/4" A	115.2
DS-RV 42-RL/WD 1)	42	L 100 (250)	32	1 1/4"	60	70	65	91.0	68.5	55	22	29.0	G 1 1/2" A	179.0
DS-RV 6-RS/WD	6	S 400 (1000)	3		17	19	19	46.0	31.5	19	12	3.5	G 1/4" A	9.0
DS-RV 8-RS/WD	8	S 400 (1000)	4		19	19	19	46.0	31.5	19	12	3.5	G 1/4" A	11.5
DS-RV 10-RS/WD	10	S 400 (1000)	6	1/8"	22	24	22	54.0	38.0	22	12	5.5	G 3/8" A	15.0
DS-RV 12-RS/WD	12	S 400 (1000)	8	1/4"	24	27	24	57.0	41.0	22	12	7.5	G 3/8" A	18.5
DS-RV 14-RS/WD	14	S 400 (1000)	10	3/8"	27	32	27	62.0	44.5	27	14	11.5	G 1/2" A	25.5
DS-RV 16-RS/WD 1)	16	S 400 (1000)	12	1/2"	30	36	32	66.0	48.0	27	14	11.5	G 1/2" A	32.0
DS-RV 20-RS/WD 1)	20	S 400 (1000)	16	1/2"	36	46	41	73.5	52.0	32	16	15.0	G 3/4" A	59.5
DS-RV 25-RS/WD 1)	25	S 250 (625)	20	3/4"	46	50	46	78.5	54.5	40	18	19.0	G 1" A	85.0
DS-RV 30-RS/WD 1)	30	S 250 (625)	25	1"	50	60	60	90.5	64.0	50	20	24.0	G 1 1/4" A	136.0
DS-RV 38-RS/WD 1)	38	S 250 (625)	32	1 1/4"	60	70	65	100.0	69.5	55	22	29.0	G 1 1/2" A	195.0

L₂ = approximate length with nut tightened

1) valve halves with O-ring sealing

Please see "Engineering and technical data - Selecting the correct tube fitting" for more information on pressure.

VALVES

NON-RETURN VALVES WITH CONE

RV NON-RETURN VALVES METRIC

Flow from male stud end.

Metric parallel.

Captive seal O-ring NBR (e.g. Perbunan),
FPM (e.g. Viton) upon request.

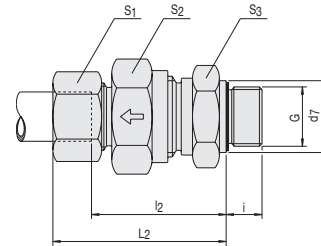

description	pipe OD	PB series	DN nominal size		S ₁	S ₂	S ₃	L ₂	l ₂	d ₇	i	bore	Metric thread	kg / 100 pcs
DS-RV 6-ML/WD	6	L 250 (625)	4		14	17	17	42.5	28.0	14	8	3.5	M 10x1	5.0
DS-RV 8-ML/WD	8	L 250 (625)	6	1/8"	17	19	19	43.5	30.0	17	12	5.5	M 12x1.5	7.2
DS-RV 10-ML/WD	10	L 250 (625)	8	1/4"	19	24	22	53.0	38.5	19	12	7.5	M 14x1.5	5.0
DS-RV 12-ML/WD	12	L 250 (625)	10	3/8"	22	30	27	57.0	42.5	22	12	9.5	M 16x1.5	18.5
DS-RV 15-ML/WD	15	L 250 (625)	12	1/2"	27	32	27	60.6	45.5	24	12	11.5	M 18x1.5	22.5
DS-RV 18-ML/WD	18	L 160 (400)	16	1/2"	32	36	36	66.0	50.0	27	14	14.0	M 22x1.5	33.5
DS-RV 22-ML/WD	22	L 160 (400)	20	3/4"	36	46	41	71.0	55.0	32	16	18.0	M 26x1.5	50.0
DS-RV 28-ML/WD	28	L 100 (250)	25	1"	41	55	50	79.5	63.0	40	18	23.0	M 33x2	78.5
DS-RV 35-ML/WD	35	L 100 (250)	32	1 1/4"	50	60	60	90.5	69.0	50	20	29.0	M 42x2	115.2
DS-RV 42-ML/WD 1)	42	L 100 (250)	32	1 1/4"	60	70	65	91.0	67.5	55	22	29.0	M 48x2	179.0
DS-RV 6-MS/WD	6	S 400 (1000)	3		17	19	19	46.0	31.5	17	12	3.5	M 12x1.5	9.0
DS-RV 8-MS/WD	8	S 400 (1000)	4		19	19	19	46.0	31.5	19	12	3.5	M 14x1.5	11.5
DS-RV 10-MS/WD	10	S 400 (1000)	6	1/8"	22	24	22	54.0	38.0	22	12	5.5	M 16x1.5	15.0
DS-RV 12-MS/WD	12	S 400 (1000)	8	1/4"	24	27	24	57.0	41.0	24	12	7.5	M 18x1.5	18.5
DS-RV 14-MS/WD	14	S 400 (1000)	10	3/8"	27	32	27	62.0	44.5	26	14	9.5	M 20x1.5	25.5
DS-RV 16-MS/WD	16	S 400 (1000)	12	1/2"	30	36	32	66.0	48.0	27	14	11.5	M 22x1.5	32.0
DS-RV 20-MS/WD 1)	20	S 400 (1000)	16	1/2"	36	46	41	73.5	52.0	32	16	15.0	M 27x2	59.5
DS-RV 25-MS/WD	25	S 250 (625)	20	3/4"	46	50	46	78.5	54.5	40	18	19.0	M 33x2	84.5
DS-RV 30-MS/WD 1)	30	S 250 (625)	25	1"	50	60	60	90.5	64.0	50	20	24.0	M 42x2	135.0
DS-RV 38-MS/WD 1)	38	S 250 (625)	32	1 1/4"	60	70	65	100.0	69.5	55	22	29.0	M 48x2	196.8

L₂ = approximate length with nut tightened

1) valve halves with O-ring sealing

Please see "Engineering and technical data - Selecting the correct tube fitting" for more information on pressure.

VALVES NON-RETURN VALVES WITH CONE

THE WORLD OF TUBE FITTINGS

RZ NON-RETURN VALVES BSP

Flow towards male stud end.

BSP parallel.

Captive seal O-ring NBR (e.g. Perbunan),
FPM (e.g. Viton) upon request.

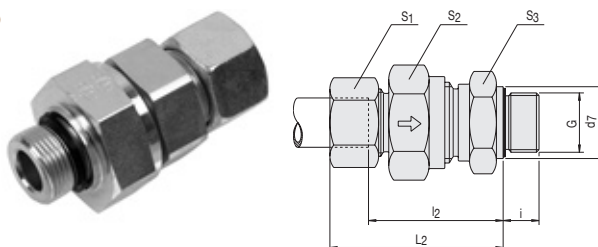

description	pipe OD	PB series	DN nominal size		S ₁	S ₂	S ₃	L ₂	L ₁	d ₇	i	bore	BSP thread	kg / 100 pcs
DS-RZ 6-RL/WD	6	L 250 (625)	4		14	17	17	41.0	26.5	14	8	3.5	G 1/8" A	5.1
DS-RZ 8-RL/WD	8	L 250 (625)	6	1/8"	17	19	19	43.0	28.5	19	12	5.5	G 1/4" A	6.5
DS-RZ 10-RL/WD	10	L 250 (625)	8	1/4"	19	24	22	53.0	38.5	19	12	7.5	G 1/4" A	8.5
DS-RZ 12-RL/WD	12	L 250 (625)	10	3/8"	22	27	30	55.0	40.5	22	12	9.5	G 3/8" A	18.0
DS-RZ 15-RL/WD	15	L 250 (625)	12	1/2"	27	27	32	57.5	42.5	27	12	11.5	G 1/2" A	21.0
DS-RZ 18-RL/WD	18	L 160 (400)	16	1/2"	32	36	36	64.0	48.0	27	14	14.0	G 1/2" A	32.0
DS-RZ 22-RL/WD	22	L 160 (400)	20	3/4"	36	41	46	72.0	56.0	32	16	18.0	G 3/4" A	49.0
DS-RZ 28-RL/WD	28	L 100 (250)	25	1"	41	50	55	80.5	64.0	40	18	23.0	G 1" A	77.0
DS-RZ 35-RL/WD	35	L 100 (250)	32	1 1/4"	50	60	60	91.5	70.0	50	20	29.0	G 1 1/4" A	114.0
DS-RZ 42-RL/WD 1)	42	L 100 (250)	32	1 1/4"	60	65	70	93.0	70.5	55	22	29.0	G 1 1/2" A	182.0
DS-RZ 6-RS/WD	6	S 400 (1000)	3		17	19	19	46.0	31.5	19	12	3.5	G 1/4" A	7.5
DS-RZ 8-RS/WD	8	S 400 (1000)	4		19	19	19	46.0	31.5	19	12	3.5	G 1/4" A	8.5
DS-RZ 10-RS/WD	10	S 400 (1000)	6	1/8"	22	22	24	54.0	38.0	22	12	5.5	G 3/8" A	15.0
DS-RZ 12-RS/WD	12	S 400 (1000)	8	1/4"	24	24	27	57.0	41.0	22	12	7.5	G 3/8" A	18.0
DS-RZ 14-RS/WD	14	S 400 (1000)	10	3/8"	27	27	32	61.0	43.5	27	14	9.5	G 1/2" A	25.2
DS-RZ 16-RS/WD 1)	16	S 400 (1000)	12	1/2"	30	32	36	64.0	46.0	27	14	11.5	G 1/2" A	32.5
DS-RZ 20-RS/WD 1)	20	S 400 (1000)	16	1/2"	36	41	46	71.5	50.0	32	16	15.0	G 3/4" A	59.0
DS-RZ 25-RS/WD 1)	25	S 250 (625)	20	3/4"	46	46	50	78.5	54.5	40	18	19.0	G 1" A	82.5
DS-RZ 30-RS/WD	30	S 250 (625)	25	1"	50	60	60	90.5	64.0	50	20	24.0	G 1 1/4" A	133.2
DS-RZ 38-RS/WD 1)	38	S 250 (625)	32	1 1/4"	60	65	70	102.0	71.5	55	22	29.0	G 1 1/2" A	197.5

L₂ = approximate length with nut tightened

1) valve halves with O-ring sealing

Please see "Engineering and technical data - Selecting the correct tube fitting" for more information on pressure.

VALVES

NON-RETURN VALVES WITH CONE

RZ NON-RETURN VALVES METRIC

Flow from male stud end.

Metric parallel.

Captive seal O-ring NBR (e.g. Perbunan),
FPM (e.g. Viton) upon request.

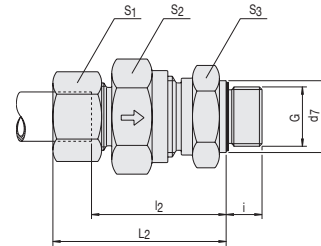

description	pipe OD	PB series	DN nominal size		S ₁	S ₂	S ₃	L ₂	l ₂	d ₇	i	bore	Metric thread	kg / 100 pcs
DS-RZ 6-ML/WD	6	L 250 (625)	4		14	17	17	41.0	26.5	14	8	3.5	M 10x1	5.1
DS-RZ 8-ML/WD	8	L 250 (625)	6	1/8"	17	19	19	43.0	28.5	17	12	5.5	M 12x1.5	6.5
DS-RZ 10-ML/WD	10	L 250 (625)	8	1/4"	19	22	24	53.0	38.5	19	12	7.5	M 14x1.5	8.5
DS-RZ 12-ML/WD	12	L 250 (625)	10	3/8"	22	27	30	55.0	40.5	22	12	9.5	M 16x1.5	18.0
DS-RZ 15-ML/WD	15	L 250 (625)	12	1/2"	27	27	32	57.5	42.5	24	12	11.5	M 18x1.5	21.0
DS-RZ 18-ML/WD	18	L 160 (400)	16	1/2"	32	36	36	64.0	48.0	27	14	14.0	M 22x1.5	32.0
DS-RZ 22-ML/WD	22	L 160 (400)	20	3/4"	36	41	46	72.0	56.0	32	16	18.0	M 26x1.5	49.0
DS-RZ 28-ML/WD	28	L 100 (250)	25	1"	41	50	55	80.5	64.0	40	18	23.0	M 33x2	77.0
DS-RZ 35-ML/WD	35	L 100 (250)	32	1 1/4"	50	60	60	91.5	70.0	50	20	29.0	M 42x2	114.0
DS-RZ 42-ML/WD 1)	42	L 100 (250)	32	1 1/4"	60	65	70	93.0	70.5	55	22	29.0	M 48x2	180.0
DS-RZ 6-MS/WD	6	S 400 (1000)	3		17	19	19	46.0	31.5	17	12	3.5	M 12x1.5	7.5
DS-RZ 8-MS/WD	8	S 400 (1000)	4	1/8"	19	19	19	46.0	31.5	19	12	3.5	M 14x1.5	8.5
DS-RZ 10-MS/WD	10	S 400 (1000)	6	1/8"	22	22	24	54.0	38.0	22	12	5.5	M 16x1.5	15.0
DS-RZ 12-MS/WD	12	S 400 (1000)	8	1/4"	24	24	27	57.0	41.0	24	12	7.5	M 18x1.5	18.0
DS-RZ 14-MS/WD	14	S 400 (1000)	10	3/8"	27	27	32	61.0	43.5	26	14	9.5	M 20x1.5	25.2
DS-RZ 16-MS/WD 1)	16	S 400 (1000)	12	1/2"	30	32	36	64.0	46.0	27	14	11.5	M 22x1.5	32.5
DS-RZ 20-MS/WD 1)	20	S 400 (1000)	16	1/2"	36	41	46	71.5	50.0	32	16	15.0	M 27x2	59.0
DS-RZ 25-MS/WD 1)	25	S 250 (625)	20	3/4"	46	46	50	78.5	54.5	40	18	19.0	M 33x2	84.0
DS-RZ 30-MS/WD	30	S 250 (625)	25	1"	50	60	60	90.5	64.0	50	20	24.0	M 42x2	134.5
DS-RZ 38-MS/WD 1)	38	S 250 (625)	32	1 1/4"	60	65	70	102.0	71.5	55	22	29.0	M 48x2	199.5

L₂ = approximate length with nut tightened

1) valve halves with O-ring sealing

Please see "Engineering and technical data - Selecting the correct tube fitting" for more information on pressure.

VALVES

NON-RETURN VALVES WITH CONE

THE WORLD OF TUBE FITTINGS

RF NON-RETURN VALVES

Twin-face inner pipe thread.

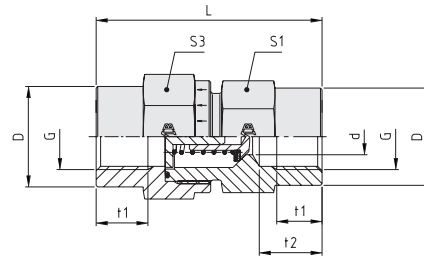

description	PB	DN nominal size	S ₁	S ₃	L	t ₁ min.	t ₂	D	d	G	kg / 100 pcs
RF 1/8"	400	3	19	19	42.5	8.0	12.0	19	3.5	G 1/8	7.6
RF 1/4"	400	4	19	19	51	12.0	16.0	19	3.5	G 1/4	8.5
RF 3/8"	400	8	24	27	60	12.0	17.0	24	7.5	G 3/8	15.6
RF 1/2"	400	12	32	36	72	15.0	20.0	32	11.5	G 1/2	34.4
RF 3/4"	1) 400	16	41	46	84	16.5	22.0	41	15.0	G 3/4	59.0
RF 1"	1) 250	20	46	50	95	19.0	25.5	46	19.0	G 1	82.3
RF 1 1/4"	1) 250	25	60	60	110	21.5	28.0	60	24.0	G 1 1/4	153.6
RF 1 1/2"	1) 250	32	65	70	114	22.0	28.5	65	29.0	G 1 1/2	193.3

1) valve halves with O-ring sealing

Please see "Engineering and technical data - Selecting the correct tube fitting" for more information on pressure.

RVS INSIDE PARTS NON-RETURN VALVES

Zinc plated steel. Other materials on request.

Perbunan standard -20°C up to +90°C.

Viton optional -20°C up to +120°C.

Valve lift pressure: Standard 1 bar, alternative valve lift pressure supplied upon request.



Assembly

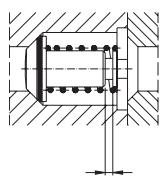

Travel of spring

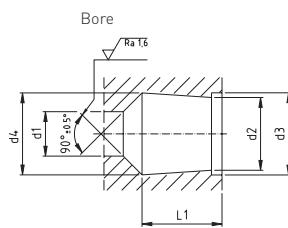

Bore (RVS 6-L/S / 8-S only)
Bore (must align exactly)

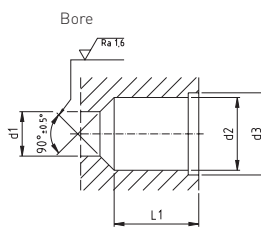

Inside valve parts

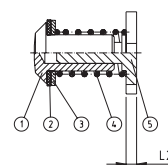

- (1) Bolt
- (2) Seal
- (3) Supporting ring
- (4) Spring
- (5) Cone guide

description	d ₁	d ₂ [+0.1]	d ₃ [+0.05]	L ₁ [± 0.1]	L ₂	deflection	d ₄ [+0.2]
X RVS 6-L/S/8-S	4	7.7	8.6	10.3	2.3	2.5	8.5
X RVS 8-L/10-S	6	10.8	11.6	12.7	2.3	2.7	10.75 [d2]
X RVS 10-L/12-S	8	13.4	14.1	16.3	2.3	3.3	13.35 [d2]
X RVS 12-L/14-S	10	16.9	18.1	18.9	2.8	3.8	16.9 [d2]
X RVS 15-L/16-S	12	19.5	20.6	21.4	2.8	4.7	19.5 [d2]
X RVS 18-L/20-S	15	25.2	27.1	25.4	3.4	4.7	25.2 [d2]
X RVS 22-L/25-S	19	30.8	32.6	29.6	3.4	5.5	30.8 [d2]
X RVS 28-L/30-S	24	38.7	40.6	34.7	3.8	7.0	38.7 [d2]
X RVS 35-L/38-S	29	45.7	48.1	40.7	3.8	10.0	45.7 [d2]

Please see "Engineering and technical data - Selecting the correct tube fitting" for more information on pressure.

VALVES

BALL CHECK VALVES

ARVA BALL CHECK VALVES

Flow towards male stud end.

BSP parallel.

Opening pressure 3 bar.

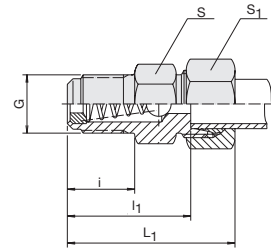

description	pipe OD	PB series	L ₁	l ₁	i	S	S ₁	G
ARVA 4-RLL	4	LL 100	30	21.0	11	11	10	G 1/8" A
ARVA 6-RLL	6	LL 100	30	19.5	11	11	12	G 1/8" A
ARVA 8-RLL	8	LL 100	31	20.5	11	12	14	G 1/8" A
DS-ARVA 8-RL	8	L 250	42	27.0	14	17	17	G 1/4" A
DS-ARVA 10-RL	10	L 250	41	26.0	14	19	19	G 1/4" A
DS-ARVA 6-RS	6	S 400	44	29.0	14	17	17	G 1/4" A

Please see "Engineering and technical data - Selecting the correct tube fitting" for more information on pressure.

ARVV BALL CHECK VALVES

Flow towards male stud end.

BSP parallel.

Opening pressure 3 bar.

Pressure difference maximum 125 bar in closing direction.

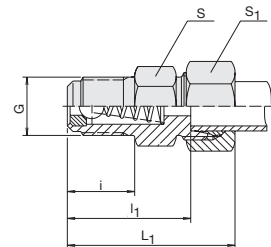

description	pipe OD	PB series	L ₁	l ₁	i	S	S ₁	G
ARVV 4-RLL	4	LL 100	30	21.0	11	11	10	G 1/8" A
ARVV 6-RLL	6	LL 100	30	19.5	11	11	12	G 1/8" A
ARVV 8-RLL	8	LL 100	31	20.5	11	12	14	G 1/8" A
DS-ARVV 8-RL	8	L 250	42	27.0	14	17	17	G 1/4" A
DS-ARVV 10-RL	10	L 250	41	26.0	14	19	19	G 1/4" A
DS-ARVV 6-RS	6	S 400	44	29.0	14	17	17	G 1/4" A

Please see "Engineering and technical data - Selecting the correct tube fitting" for more information on pressure.

THE WORLD OF TUBE FITTINGS
INTEGRATED FLUID POWER SOLUTIONS



SINGLE PARTS



SINGLE PARTS CUTTING RING

THE WORLD OF TUBE FITTINGS

DS CUTTING RING

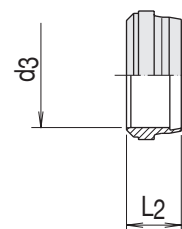

description	pipe OD	L ₂	d ₃
S 4-LL	4	6.0	4
S 6-LL	6	7.0	6
S 8-LL	8	7.0	8
DS 6-L/S	6	9.5	6
DS 8-L/S	8	9.5	8
DS 10-L/S	10	10.0	10
DS 12-L/S	12	10.0	12
DS 15-L	15	10.2	15
DS 18-L	18	10.2	18
DS 22-L	22	11.5	22
DS 28-L	28	11.5	28
DS 35-L	35	13.5	35
DS 42-L	42	13.5	42
DS 6-L/S	6	9.5	6
DS 8-L/S	8	9.5	8
DS 10-L/S	10	10.0	10
DS 12-L/S	12	10.0	12
DS 14-S	14	10.5	14
DS 16-S	16	10.5	16
DS 20-S	20	12.7	20
DS 25-S	25	12.7	25
DS 30-S	30	13.5	30
DS 38-S	38	13.5	38

Please see "Engineering and technical data - Selecting the correct tube fitting" for more information on pressure.

SINGLE PARTS CUTTING RING

DSW CUTTING RING

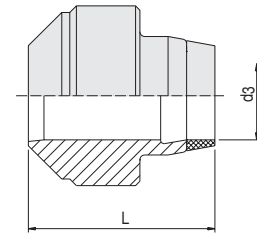

description	pipe OD	PN series	d ₃	L
DSW 6-L/S	6	L 500	6	10.5
DSW 8-L/S	8	L 500	8	10.5
DSW 10-L/S	10	L 500	10	10.5
DSW 12-L/S	12	L 400	12	10.5
DSW 15-L	15	L 400	15	10.5
DSW 18-L	18	L 400	18	11.0
DSW 22-L	22	L 250	22	11.7
DSW 28-L	28	L 250	28	11.7
DSW 35-L	35	L 250	35	14.5
DSW 42-L	42	L 250	42	14.5
DSW 6-L/S	6	S 800	6	10.5
DSW 8-L/S	8	S 800	8	10.5
DSW 10-L/S	10	S 800	10	10.5
DSW 12-L/S	12	S 630	12	10.5
DSW 14-S	14	S 630	14	11.0
DSW 16-S	16	S 630	16	11.0
DSW 20-S	20	S 400	20	14.0
DSW 25-S	25	S 400	25	14.0
DSW 30-S	30	S 400	30	15.0
DSW 38-S	38	S 400	38	15.0

Please see "Engineering and technical data - Selecting the correct tube fitting" for more information on pressure.

SINGLE PARTS NUT

THE WORLD OF TUBE FITTINGS

M LOCK NUT

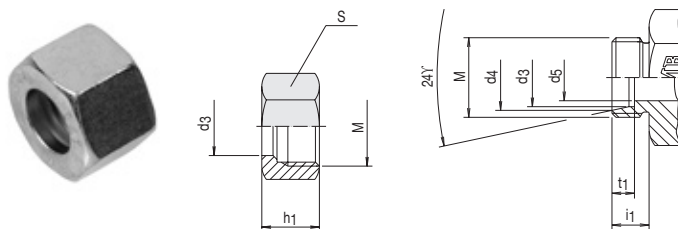

description	pipe OD	M	d ₃	d ₄	d ₅	t ₁	i ₁	S	h ₁
M 4-LL	4	M 8x1	4	5.0	3.0	4.0	8	10	11.5
M 6-LL	6	M 10x1	6	7.5	4.5	5.5	8	12	12.0
M 8-LL	8	M 12x1	8	9.5	6.0	5.5	9	14	12.5
M 6-L	6	M 12x1.5	6	8.1	4.0	7.0	10	14	15.0
M 8-L	8	M 14x1.5	8	10.1	6.0	7.0	10	17	15.0
M 10-L	10	M 16x1.5	10	12.3	8.0	7.0	11	19	16.0
M 12-L	12	M 18x1.5	12	14.3	10.0	7.0	11	22	16.0
M 15-L	15	M 22x1.5	15	17.3	12.0	7.0	12	27	17.5
M 18-L	18	M 26x1.5	18	20.3	15.0	7.5	12	32	18.0
M 22-L	22	M 30x2	22	24.3	19.0	7.5	14	36	20.5
M 28-L	28	M 36x2	28	30.3	24.0	7.5	14	41	22.0
M 35-L	35	M 45x2	35	38.0	30.0	10.5	16	50	25.0
M 42-L	42	M 52x2	42	45.0	36.0	11.0	16	60	25.0
M 6-S	6	M 14x1.5	6	8.1	4.0	7.0	12	17	16.0
M 8-S	8	M 16x1.5	8	10.1	5.0	7.0	12	19	16.0
M 10-S	10	M 18x1.5	10	12.3	7.0	7.5	12	22	17.5
M 12-S	12	M 20x1.5	12	14.3	8.0	7.5	12	24	18.0
M 14-S	14	M 22x1.5	14	16.3	10.0	8.0	14	27	20.0
M 16-S	16	M 24x1.5	16	18.3	12.0	8.5	14	30	21.0
M 20-S	20	M 30x2	20	22.9	16.0	10.5	16	36	24.0
M 25-S	25	M 36x2	25	27.9	20.0	12.0	18	46	26.5
M 30-S	30	M 42x2	30	33.0	25.0	13.5	20	50	29.5
M 38-S	38	M 52x2	38	41.0	32.0	16.0	22	60	32.5

Please see "Engineering and technical data - Selecting the correct tube fitting" for more information on pressure.

SINGLE PARTS NUT

UES INTERNAL COUPLING NUT

Thread: Metric, parallel.

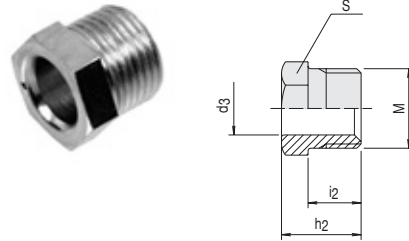

description	pipe OD	PN series	M	d ₃	h ₂	i ₂	S	kg / 100 pcs
UE S 4-LL	4	LL 100	M 8x1	4	12	8.0	8	0.2
UE S 6-LL	6	LL 100	M 10x1	6	13	9.0	10	0.4
UE S 8-LL	8	LL 100	M 12x1	8	14	9.5	12	0.6
UE S 6-L	6	L 500	M 12x1.5	6	16	11.5	12	0.9
UE S 8-L	8	L 500	M 14x1.5	8	16	11.5	14	1.1
UE S 10-L	10	L 500	M 16x1.5	10	17	11.5	17	1.5
UE S 12-L	12	L 400	M 18x1.5	12	18	12.0	19	1.9

Please see "Engineering and technical data - Selecting the correct tube fitting" for more information on pressure.

GM COUNTER NUT

For bulkhead connections.

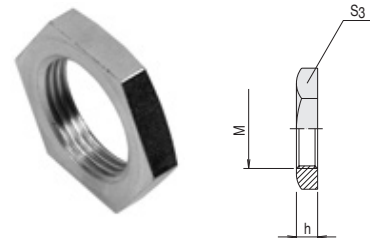

description	M	S ₃	h	kg / 100 pcs
GM 6-L	M 12x1.5	17	6	0.7
GM 6-S/ 8-L	M 14x1.5	19	6	0.8
GM 8-S/10-L	M 16x1.5	22	6	1.1
GM 10-S/12-L	M 18x1.5	24	6	1.2
GM 12-S	M 20x1.5	27	6	1.5
GM 14-S/15-L	M 22x1.5	30	7	2.2
GM 16-S	M 24x1.5	32	7	2.4
GM 18-L	M 26x1.5	36	8	3.7
GM 20-S/22-L	M 30x2	41	8	4.6
GM 25-S/28-L	M 36x2	46	9	6.0
GM 30-S	M 42x2	50	9	5.8
GM 35-L	M 45x2	55	9	7.5
GM 38-S/42-L	M 52x2	65	10	12.3

Please see "Engineering and technical data - Selecting the correct tube fitting" for more information on pressure.

SINGLE PARTS PLUG

THE WORLD OF TUBE FITTINGS

VSCH BLANKING PLUG

With internal hexagon and captive seal NBR (e.g. Perbunan).

Thread: BSP parallel, metric parallel.

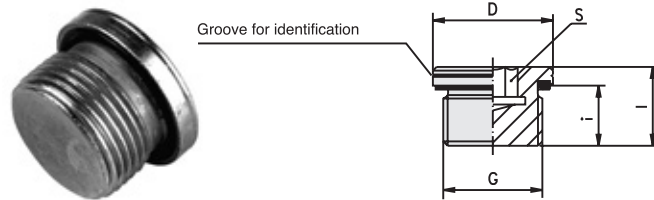

description	PN	G	D	I	i	S	MA*/NM
VSCH-M10x1/WD	400	M 10x1	14	12.0	8	5	10
VSCH-M 12x1.5/WD	400	M 12x1.5	17	17.0	12	6	20
VSCH-M 14x1.5/WD	400	M 14x1.5	19	17.0	12	6	30
VSCH-M 16x1.5/WD	400	M 16x1.5	22	17.0	12	8	40
VSCH-M 18x1.5/WD	400	M 18x1.5	24	17.0	12	8	50
VSCH-M 20x1.5/WD	400	M 20x1.5	26	19.0	14	10	60
VSCH-M 22x1.5/WD	400	M 22x1.5	27	19.0	14	10	80
VSCH-M 26x1.5/WD	400	M 26x1.5	32	21.0	16	12	100
VSCH-M 27x2/WD	400	M 27x2	32	21.0	16	12	120
VSCH-M 33x2/WD	400	M 33x2	40	22.5	16	17	200
VSCH-M 42x2/WD	315	M 42x2	50	22.5	16	22	350
VSCH-M 48x2/WD	315	M 48x2	55	22.5	16	24	400
VSCH-R 1/8"/WD	400	G 1/8" A	14	12.0	8	5	10
VSCH-R 1/4"/WD	400	G 1/4" A	19	17.0	12	6	30
VSCH-R 3/8"/WD	400	G 3/8" A	22	17.0	12	8	40
VSCH-R 1/2"/WD	400	G 1/2" A	27	19.0	14	10	80
VSCH-R 3/4"/WD	400	G 3/4" A	32	21.0	16	12	120
VSCH-R 1"/WD	400	G 1" A	40	22.5	16	17	200
VSCH-R 1 1/4"/WD	315	G 1 1/4" A	50	22.5	16	22	350
VSCH-R 1 1/2"/WD	315	G 1 1/2" A	55	22.5	16	24	400

* MA = tightening torques relate to steel counterparts

Please see "Engineering and technical data - Selecting the correct tube fitting" for more information on
- internal screw threads.
- pressure.

SINGLE PARTS PLUG

VSCHK STANDPIPE END PLUG

With 24° inner cone.

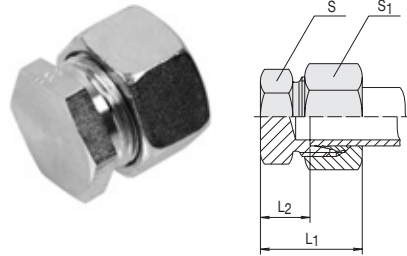

description	pipe OD	PN series	S	S ₁	L ₁	L ₂
DS-VSCHK 6-L	6	L 500 (2200)	12	14	22	7.0
DS-VSCHK 8-L	8	L 500 (2200)	14	17	23	8.0
DS-VSCHK 10-L	10	L 500 (2200)	17	19	24	9.0
DS-VSCHK 12-L	12	L 400 (1700)	19	22	25	10.0
DS-VSCHK 15-L	15	L 400 (1700)	24	27	26	11.0
DS-VSCHK 18-L	18	L 400 (1700)	27	32	28	11.5
DS-VSCHK 22-L	22	L 250 (1100)	32	36	30	13.5
DS-VSCHK 28-L	28	L 250 (1100)	41	41	31	14.5
DS-VSCHK 35-L	35	L 250 (1100)	46	50	36	14.5
DS-VSCHK 42-L	42	L 250 (1100)	55	60	39	16.0
DS-VSCHK 6-S	6	S 800 (3400)	14	17	26	11.0
DS-VSCHK 8-S	8	S 800 (3400)	17	19	28	13.0
DS-VSCHK 10-S	10	S 800 (3400)	19	22	29	12.5
DS-VSCHK 12-S	12	S 630 (2700)	22	24	31	14.5
DS-VSCHK 14-S	14	S 630 (2700)	24	27	34	16.0
DS-VSCHK 16-S	16	S 630 (2700)	27	30	34	15.5
DS-VSCHK 20-S	20	S 400 (1700)	32	36	39	17.5
DS-VSCHK 25-S	25	S 400 (1700)	41	46	44	20.0
DS-VSCHK 30-S	30	S 400 (1700)	46	50	47	20.5
DS-VSCHK 38-S	38	S 400 (1700)	55	60	54	23.0

L₁ = approximate length with tightened nut

*Please see "Engineering and technical data - Selecting the correct tube fitting" for more information on
- internal screw threads.
- pressure.*

SINGLE PARTS PLUG

THE WORLD OF TUBE FITTINGS

STO BLANKING PLUG

For cones with taper and O-ring according to DIN 3865.

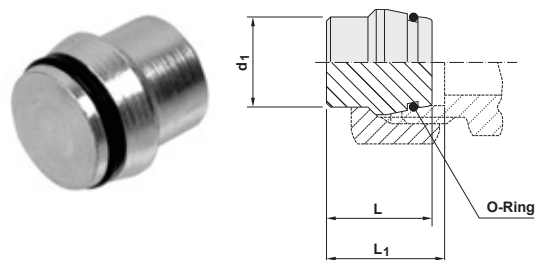

description	pipe OD	PN series	L	L ₁	O-Ring	kg / 100 pcs
STO 6-L/S/O	6	L 500 (2200)	18.5	20.0	4x1.5	0.6
STO 8-L/S/O	8	L 500 (2200)	18.5	20.0	6x1.5	0.9
STO 10-L/S/O	10	L 500 (2200)	20.0	21.0	7.5x1.5	1.4
STO 12-L/S/O	12	L 400 (1700)	20.5	21.5	9x1.5	1.9
STO 15-L/O	15	L 400 (1700)	20.5	21.5	12x2	3.1
STO 18-L/O	18	L 400 (1700)	22.5	24.0	15x2	6.2
STO 22-L/O	22	L 250 (1100)	25.0	26.5	20x2	9.9
STO 28-L/O	28	L 250 (1100)	25.5	27.0	26x2	15.1
STO 35-L/O	35	L 250 (1100)	30.0	33.0	32x2.5	25.2
STO 42-L/O	42	L 250 (1100)	30.0	33.5	38x2.5	35.9
STO 6-L/S/O	6	S 800 (3400)	18.5	20.0	4x1.5	0.6
STO 8-L/S/O	8	S 800 (3400)	18.5	20.0	6x1.5	0.9
STO 10-L/S/O	10	S 800 (3400)	20.0	21.5	7.5x1.5	1.4
STO 12-L/S/O	12	S 630 (2700)	20.5	22.0	9x1.5	1.9
STO 14-S/O	14	S 630 (2700)	22.5	24.5	10x2	2.6
STO 16-S/O	16	S 630 (2700)	23.5	26.0	12x2	4.6
STO 20-S/O	20	S 400 (1700)	28.5	31.5	16.3x2.4	7.7
STO 25-S/O	25	S 400 (1700)	29.0	32.5	20.3x2.4	11.9
STO 30-S/O	30	S 400 (1700)	30.5	35.5	25.3x2.4	17.9
STO 38-S/O	38	S 400 (1700)	33.0	40.5	33.4x2.4	30.8

Please see "Engineering and technical data - Selecting the correct tube fitting" for more information on pressure.

SINGLE PARTS SEALING RING

DKA/DKAD SEAL EDGE RING

For banjo couplings and swiveling screw-fittings
SBE, SGE, SB, and SBD.

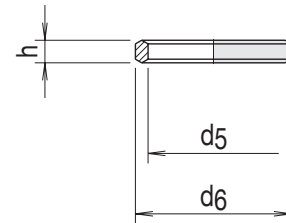

description	use SBE../SGE..	h	kg / 100 pcs	G	d ₅	d ₆
DKA R 1/8"/SA 2.5	6-RL	2.5	0.1	G 1/8" A	10.0	14
DKA R 1/4"/SA 3	8-RL; 6-RS	3.0	0.2	G 1/4" A	13.2	18
DKA R 3/8"/SA 3	12-RL; 10-RS	3.0	0.3	G 3/8" A	16.7	22
DKA R 1/2"/SA 4.5	15-RL; 14-RS	4.5	0.6	G 1/2" A	21.0	26
DKAD R 3/4"	22-RL; 20-RS	3.5	0.6	G 3/4" A	26.4	32
DKA R 1"/M33/SA3.5	28-RL; 25-RS	3.5	0.9	G 1" A	33.3	39
DKA R 1 1/4"/M42/SA3.5	35-RL; 30-RS	3.5	1.2	G 1 1/4" A	42.0	49
DKA R 1 1/2"/M48/SA3.5	42-RL; 38-RS	3.5	1.4	G 1 1/2" A	48.0	55
DKA M10/SA2.5	6-ML	2.5	0.1	M 10x1	10.0	14
DKA M12/SA3	8-ML; 6-MS	3.0	0.2	M 12x1.5	12.0	17
DKA M14/SA3	10-ML; 8-MS	3.0	0.3	M 14x1.5	14.0	19
DKA M16/SA3	12-ML; 10-MS	3.0	0.3	M 16x1.5	16.0	21
DKA M18/SA3	15-ML; 12-MS	3.0	0.3	M 18x1.5	18.0	23
DKA M20/SA3	14-MS	3.0	0.4	M 20x1.5	20.0	25
DKA M22	18-ML; 16-MS	4.5	0.6	M 22x1.5	22.0	27
DKAD M26	22-ML	3.5	0.5	M 26x1.5	26.0	31
DKAD M27	20-MS	3.5	0.6	M 27x2	27.0	32
DKA R 1"/M33/SA3.5	28-ML; 25-MS	3.5	0.8	M 33x2	33.3	39
DKA R 1 1/4"/M42/SA3.5	35-ML; 30-MS	3.5	1.2	M 42x2	42.0	49
DKA R 1 1/2"/M48/SA3.5	42-ML; 38-MS	3.5	1.4	M 48x2	48.0	55

Please see "Engineering and technical data - Selecting the correct tube fitting" for more information on pressure.

SINGLE PARTS SEALING RING

THE WORLD OF TUBE FITTINGS

DKA/DKAD SEAL EDGE RING

For banjo couplings and swiveling screw-fittings SBE, SGE, SB, and SBD.

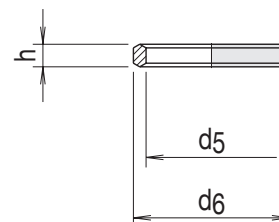

description	use SB../	h	kg / 100 pcs	G	d ₅	d ₆
DKA R 1/8"/M10	6-RL	3.7	0.2	G 1/8" A	10.0	14
DKA R 1/4"	8-RL; 6-RS	4.5	0.3	G 1/4" A	13.2	18
DKA R 3/8"	12-RL; 10-RS	4.5	0.4	G 3/8" A	16.7	22
DKA R 1/2"	15-RL; 14-RS	5.5	0.7	G 1/2" A	21.0	26
DKA R 3/4"	22-RL; 20-RS	5.0	0.7	G 3/4" A	26.4	32
DKA R 1"/M33	28-RL; 25-RS	6.0	1.1	G 1" A	33.3	39
DKA R 1 1/4"/M42	35-RL; 30-RS	6.5	1.3	G 1 1/4" A	42.0	49
DKA R 1 1/2"/M48	42-RL; 38-RS	6.5	1.5	G 1 1/2" A	48.0	55
DKA R 1/8"/M10	6-ML	3.7	0.2	M 10x1	10.0	14
DKA M12	8-ML; 6-MS	4.5	0.3	M 12x1.5	12.0	17
DKA M14	10-ML; 8-MS	4.5	0.4	M 14x1.5	14.0	19
DKA M16	12-ML; 10-MS	4.5	0.4	M 16x1.5	16.0	21
DKA M18	15-ML; 12-MS	4.5	0.4	M 18x1.5	18.0	23
DKA M20	14-MS	4.5	0.5	M 20x1.5	20.0	25
DKA M22	18-ML; 16-MS	4.5	0.6	M 22x1.5	22.0	27
DKA M26	22-ML	4.5	0.6	M 26x1.5	26.0	31
DKA M27	20-MS	5.5	0.7	M 27x2	27.0	32
DKA R 1"/M33	28-ML; 25-MS	6.0	1.0	M 33x2	33.3	39
DKA R 1 1/4"/M42	35-ML; 30-MS	6.5	1.3	M 42x2	42.0	49
DKA R 1 1/2"/M48	42-ML; 38-MS	6.5	1.5	M 48x2	48.0	55

Please see "Engineering and technical data - Selecting the correct tube fitting" for more information on pressure.

description	use SB../	h	kg / 100 pcs	G	d ₅	d ₆
DKAD R 1/2"	18-RL	3.5	0.5	G 1/2" A	21.0	26
DKAD R 3/4"	22-RL	3.5	0.6	G 3/4" A	26.5	32
DKAD R 1/2"	16-RS	3.5	0.5	G 1/2" A	21.0	26
DKAD R 3/4"	20-RS	3.5	0.6	G 3/4" A	26.5	32
DKAD M 22	18-ML	3.5	0.5	M 22 x 1.5	22.0	27
DKAD M 26	22-ML	3.5	0.6	M 26 x 1.5	26.0	31
DKAD M 22	16-MS	3.5	0.5	M 22 x 1.5	22.0	27
DKAD M 27	20-MS	3.5	0.6	M 27 x 2	27.0	32

Please see "Engineering and technical data - Selecting the correct tube fitting" for more information on pressure.

SINGLE PARTS SEALING RING

DKI SEAL EDGE RING

Packing rings for pressure gauge screw connection.

description	for internal thread	d_5	d_6	h
DKI R 1/4"	G 1/4"	6	11.3	4.5
DKI R 1/2"	G 1/2"	12	18.5	5.0

Please see "Engineering and technical data - Selecting the correct tube fitting" for more information on pressure.

WD CAPTIVE SEAL

For stud threads DIN 3852-11.

Materials WD: NBR (e.g. Perbunan),
and FPM (e.g. Viton).

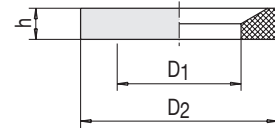

description	stud thread	mm DIN 3869	D_1	D_2	h
WD M 8 x 1 / ...	M 8 x 1	8	6.5	9.9	1.0
WD R 1/8" / M 10 x 1 / ...	M 10 x 1 / G 1/8" A	10	8.4	11.9	1.0
WD M 12 x 1.5 / ...	M 12 x 1.5	12	9.8	14.4	1.5
WD R 1/4" / M 14 x 1.5 / ...	M 14 x 1.5 / G 1/4" A	14	11.6	16.5	1.5
WD M 16 x 1.5 / ...	M 16 x 1.5	16	13.8	18.9	1.5
WD R 3/8" / ...	G 3/8" A	17	14.7	18.9	1.5
WD M 18 x 1.5 / ...	M 18 x 1.5	18	15.7	20.9	1.5
WD M 20 x 1.5 / ...	M 20 x 1.5	20	17.8	22.9	1.5
WD R 1/2" / ...	G 1/2" A	21	18.5	23.9	1.5
WD M 22 x 1.5 / ...	M 22 x 1.5	22	19.6	24.3	1.5
WD R 3/4" / M 26 / M 27 / ...	M 26 x 1.5 / M 27 x 2 / G 3/4" A	27	23.9	29.2	1.5
WD R 1" / M 33 x 2 / ...	M 33 x 2 / G 1" A	33	29.7	35.7	2.0
WD R 1 1/4" / M 42 x 2 / ...	M 42 x 2 / G 1 1/4" A	42	38.8	45.8	2.0
WD R 1 1/2" / M 48 x 2 / ...	M 48 x 2 / G 1 1/2" A	48	44.7	50.7	2.0

Please see "Engineering and technical data - Selecting the correct tube fitting" for more information on pressure.

SINGLE PARTS SEALING RING

THE WORLD OF TUBE FITTINGS

TR SEALING RING

For DSW-rings.

Materials WD: NBR (e.g. Perbunan),
and FPM (e.g. Viton).

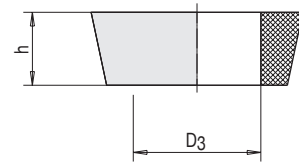

description	h	D ₃
TR 6-L/S	1.5	5.7
TR 8-L/S	1.5	7.7
TR 10-L/S	1.5	9.7
TR 12-L/S	1.5	11.7
TR 15-L	1.5	14.7
TR 18-L	1.5	17.7
TR 22-L	1.2	21.7
TR 28-L	1.2	27.7
TR 35-L	2.0	34.6
TR 42-L	2.0	41.6
TR 6-L/S	1.5	5.7
TR 8-L/S	1.5	7.7
TR 10-L/S	1.5	9.7
TR 12-L/S	1.5	11.7
TR 14-S	1.5	13.7
TR 16-S	1.5	15.7
TR 20-S	2.0	19.7
TR 25-S	2.0	24.7
TR 30-S	2.0	29.6
TR 38-S	2.0	37.6

Please see "Engineering and technical data - Selecting the correct tube fitting" for more information on pressure.

SINGLE PARTS SEALING RING

KDE RETAINING RING

For banjo couplings SBE.

Matches counter bore according to DIN 3852.

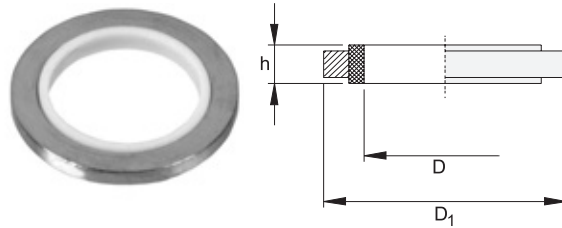

description	use SBE...	D ₁	D	h
KDE R 1/8" / M10	6-RL	17	10.2	2.5
KDE R 1/4"	6-RS; 8-RL/-RS; 10-RL	22	13.3	3.0
KDE R 3/8"	10-RS; 12-RL/-RS	27	16.8	3.0
KDE R 1/2"	14-RS; 15-RL; 16-RS; 18-RL	32	21.1	4.5
KDE R 3/4" / M26 / M27	20-RS/-MS; 22-RL	41	27.3	3.5
KDE R 1" / M33	25-RS/-MS; 28-RL/-ML	46	33.4	3.5
KDE R 1 1/4" / M42	30-RS/-MS; 35-RL/-ML	57	42.4	3.5
KDE R 1 1/2" / M48	38-RS/-RL; 42-RL/-ML	64	48.4	3.5
KDE M12	6-MS; 8-ML	22	12.2	3.0
KDE M14	8-MS; 10-ML	23	14.3	3.0
KDE M16	10-MS; 12-ML	27	16.3	3.0
KDE M18	12-MS; 15-ML	29	18.3	3.0
KDE M20	14-MS	32	20.3	3.0
KDE M22	16-MS; 18-ML	32	22.3	4.5

Please see "Engineering and technical data - Selecting the correct tube fitting" for more information on pressure.

SINGLE PARTS SEALING RING

THE WORLD OF TUBE FITTINGS

EDE RETAINING RING

With captive seal (NBR) for banjo couplings SBE/SGE.

Matches „narrow” counter bore according to DIN 3852.

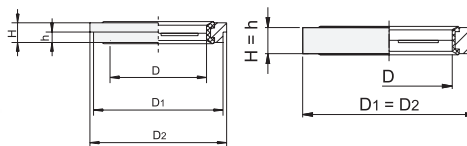

description	use SBE./ SGE..	Version	fem. thread	D	D ₁	D ₂	H	h	kg / 100 pcs
EDE R 1/8" - M 10	6-ML/RL	1	M 10 x 1 / G 1/8" A	10.1	14.9	16.0	2.5	1.1	0.2
EDE M 12	6-MS/8-ML	1	M 12 x 1.5	12.1	16.9	18.0	3.0	1.6	0.5
EDE R 1/4" - M 14	6-RS	1	M 14 x1.5 / G 1/4" A	14.1	18.9	20.0	3.0	1.6	0.4
EDE R 1/4" - M 14	8-RL/MS/RS	1	M 14 x1.5 / G 1/4" A	14.1	18.9	20.0	3.0	1.6	0.4
EDE R 1/4" - M 14	10-ML/RL	1	M 14 x1.5 / G 1/4" A	14.1	18.9	20.0	3.0	1.6	0.4
EDE R 3/8" - M 16	10-MS/RS	1	M 16 x 1.5 / G 3/8" A	16.7	21.9	24.0	3.0	2.1	0.6
EDE R 3/8" - M 16	12-ML/RL/RS	1	M 16 x 1.5 / G 3/8" A	16.7	21.9	24.0	3.0	2.1	0.6
EDE M 18	12-MS/15-ML	2	M 18 x 1.5	18.1	23.9	23.9	3.0	-	0.7
EDE R 1/2" - M 22	14-RS/15-RL	1	M 22 x 1.5 / G 1/2" A	22.1	26.9	30.0	4.5	2.6	1.2
EDE R 1/2" - M 22	16-MS/RS	1	M 22 x 1.5 / G 1/2" A	22.1	26.9	30.0	4.5	2.6	1.2
EDE R 1/2" - M 22	18-ML/RL	1	M 22 x 1.5 / G 1/2" A	22.1	26.9	30.0	4.5	2.6	1.2
EDE M 26	22-ML	1	M 26 x 1.5	26.1	31.9	35.0	3.5	2.6	1.8
EDE R 3/4" - M 27	20-MS/RS	1	M 27 x 2 / G 3/4" A	27.1	32.9	38.0	3.5	2.6	1.7
EDE R 3/4" - M 27	22-RL	1	M 27 x 2 / G 3/4" A	27.1	32.9	38.0	3.5	2.6	1.7
EDE R 1" - M 33	25-MS/RS	1	M 33 x 2 / G 1" A	33.3	39.9	42.0	3.5	2.6	1.7
EDE R 1" - M 33	28-ML/RL	1	M 33 x 2 / G 1" A	33.3	39.9	42.0	3.5	2.6	1.7
EDE R 1 1/4" - M 42	30-MS/RS	2	M 42 x 2 / G 1 1/4" A	42.2	49.9	49.9	3.5	-	2.6
EDE R 1 1/4" - M 42	35-ML/RL	2	M 42 x 2 / G 1 1/4" A	42.2	49.9	49.9	3.5	-	2.6
EDE R 1 1/2" - M 48	38-MS/RS	1	M 48 x 2 / G 1 1/2" A	48.2	55.9	60.0	3.5	2.6	3.2
EDE R 1 1/2" - M 48	42-ML/RL	1	M 48 x 2 / G 1 1/2" A	48.2	55.9	60.0	3.5	2.6	3.2

Version 1: with countersink

Version 2: without countersink $D_1=D_2$

Please see "Engineering and technical data - Selecting the correct tube fitting" for more information on pressure.

SINGLE PARTS

VSH SUPPORT SLEEVE

VSH SUPPORT SLEEVE

For safe assembly of couplings on plastic, non-ferrous metal and thin-walled steel tubes.

Available in stainless steel (1.4571) as well.

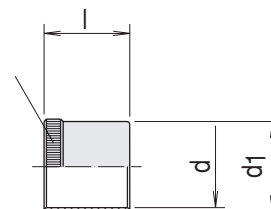

description	Tube OD x wall thickness	Tube int. Ø	l	d	d ₁
VSH 6x1	6x1	4.0	15.5	2.6	3.8
VSH 6x0.75	6x0.75	4.5	15.5	3.1	4.3
VSH 6x0.5	6x0.5	5.0	15.5	3.6	4.8
VSH 8x1	8x1	6.0	15.5	4.6	5.8
VSH 8x0.5/10x1.5	8x0.5/10x1.5	7.0	17.0	5.6	6.8
VSH 10x1	10x1	8.0	16.5	6.6	7.8
VSH 12x1.5	12x1.5	9.0	16.5	7.6	8.8
VSH 12x1	12x1	10.0	16.5	8.6	9.8
VSH 14x1/15x1.5	14x1/15x1.5	12.0	17.5	10.6	11.8
VSH 15x1/16x1.5	15x1/16x1.5	13.0	18.5	11.6	12.8
VSH 16x1/18x2	16x1/18x2	14.0	18.5	12.2	13.8
VSH 18x1.5	18x1.5	15.0	17.5	13.2	14.8
VSH 18x1/20x2	18x1/20x2	16.0	22.0	14.2	15.8
VSH 20x1.5	20x1.5	17.0	22.0	15.2	16.8
VSH 20x1/22x2	20x1/22x2	18.0	22.0	16.2	17.8
VSH 22x1.5	22x1.5	19.0	18.0	17.2	18.8
VSH 22x1/25x2.5	22x1/25x2.5	20.0	23.5	18.2	19.8
VSH 25x2	25x2	21.0	23.5	19.2	20.8
VSH 25x1.5	25x1.5	22.0	23.5	20.2	21.8
VSH 28x2	28x2	24.0	18.0	22.2	23.8
VSH 28x1.5	28x1.5	25.0	18.0	23.2	24.8
VSH 28x1/30x2	28x1/30x2	26.0	25.5	24.2	25.8
VSH 35x2.5	35x2.5	30.0	22.5	27.8	29.8
VSH 35x2	35x2	31.0	22.5	28.8	30.8
VSH 35x1.5	35x1.5	32.0	22.5	29.8	31.8
VSH 38x2.5	38x2.5	33.0	22.5	30.8	32.8
VSH 42x2	42x2	38.0	23.5	35.8	37.8

Please see "Engineering and technical data - Selecting the correct tube fitting" for
 - the table on the application of reinforcing sleeves.
 - more information on pressure.

THE WORLD OF TUBE FITTINGS
INTEGRATED FLUID POWER SOLUTIONS



WELDING NIPPLE-PIPE SCREW JOINTS



WELDING NIPPLE-PIPE SCREW JOINTS WELDING NIPPLES

THE WORLD OF TUBE FITTINGS

SNO WELDING NIPPLE WITH O-RING SEAL

NBR O-ring (e.g. Perbunan) supplied separately, to be fitted after welding.

FPM O-ring (e.g. Viton) supplied on request.

Special dimensions and materials upon request.

Welding end without tube centre.

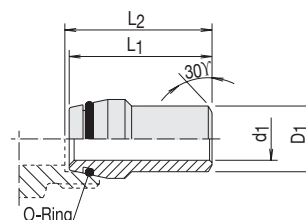

description	pipe dimension	PN-V*	PB**	d ₁	L ₁	L ₂	O-Ring	kg / 100 pcs
SNO 15x1.5	15x1.5	400	160	12.0	33.5	33.5	12x2	2.3
SNO 15x2	15x2	400	160	11.0	33.5	33.5	12x2	2.7
SNO 18x2	18x2	400	100	14.0	35.0	33.5	15x2	3.2
SNO 18x2.75	18x2.75	400	160	12.5	35.0	33.5	15x2	4.4
SNO 22x2	22x2	250	100	18.0	37.5	33.5	20x2	4.0
SNO 22x2.5	22x2.5	250	100	17.0	37.5	33.5	20x2	5.0
SNO 22x3	22x3	250	160	16.0	37.5	40.5	20x2	5.6
SNO 28x2.5	28x2.5	250	100	23.0	40.5	40.5	26x2	7.4
SNO 28x3	28x3	250	100	22.0	40.5	40.5	26x2	8.2
SNO 35x3	35x3	250	100	29.0	46.0	40.5	32x2	12.0
SNO 42x3	42x3	250	100	36.0	46.0	47.0	38x2	14.7
SNO 42x4	42x4	250	100	34.0	46.0	47.0	38x2	18.6

* Rated Pressure (PN) for the equivalent fitting. L-series ** Maximum operating pressure (PB) for SNO and tube
Please see "Engineering and technical data - Selecting the correct tube fitting" for more information on pressure.

description	pipe dimension	PN-V*	PB**	d ₁	L ₁	L ₂	O-Ring	kg / 100 pcs
SNO 10x1	10x1	800	249	8	31.5	33.5	7.5x1.5	1.0
SNO 10x1.5	10x1.5	800	358	7	31.5	33.5	7.5x1.5	1.3
SNO 10x2	10x2	800	460	6	31.5	33.5	7.5x1.5	1.5
SNO 12x1.5	12x1.5	630	305	9	31.5	33.5	9x1.5	1.5
SNO 12x2	12x2	630	391	8	31.5	33.5	9x1.5	1.9
SNO 12x2.5	12x2.5	630	474	7	31.5	33.5	9x1.5	2.2
SNO 16x1.5	16x1.5	630	234	13	37.5	40.5	12x2	2.7
SNO 16x2	16x2	630	303	12	37.5	40.5	12x2	3.1
SNO 16x2.5	16x2.5	630	370	11	37.5	40.5	12x2	3.6
SNO 16x3	16x3	630	433	10	37.5	40.5	12x2	4.1
SNO 20x2	20x2	400	249	16	43.5	47.0	16.3x2.4	5.4
SNO 20x2.5	20x2.5	400	305	15	43.5	47.0	16.3x2.4	5.7
SNO 20x3	20x3	400	357	14	43.5	47.0	16.3x2.4	6.2
SNO 20x4	20x4	400	458	12	43.5	47.0	16.3x2.4	7.8
SNO 25x3	25x3	400	292	19	49.5	53.5	20.3x2.4	8.9
SNO 25x4	25x4	400	378	17	49.5	53.5	20.3x2.4	11.1
SNO 25x5	25x5	400	458	15	49.5	53.5	20.3x2.4	12.5
SNO 30x3	30x3	400	249	24	52.0	57.5	25.3x2.4	13.5
SNO 30x4	30x4	400	321	22	52.0	57.5	25.3x2.4	14.0
SNO 30x5	30x5	400	391	20	52.0	57.5	25.3x2.4	16.6
SNO 30x6	30x6	400	460	18	52.0	57.5	25.3x2.4	17.1
SNO 38x4	38x4	400	260	30	56.5	64.5	33.3x2.4	19.5
SNO 38x5	38x5	400	318	28	56.5	64.5	33.3x2.4	23.6
SNO 38x6	38x6	400	373	26	56.5	64.5	33.3x2.4	27.0
SNO 38x7	38x7	400	428	24	56.5	64.5	33.3x2.4	28.6

* Rated Pressure (PN) for the equivalent fitting. S-series ** Maximum operating pressure (PB) for SNO and tube
Please see "Engineering and technical data - Selecting the correct tube fitting" for more information on pressure.

WELDING NIPPLE-PIPE SCREW JOINTS WELDING NIPPLES

SNR WELDING NIPPLE REDUCER

NBR O-ring (e.g. Perbunan) supplied separately, to be fitted after welding.

FPM O-ring (e.g. Viton) supplied on request.

Special dimensions and materials upon request.

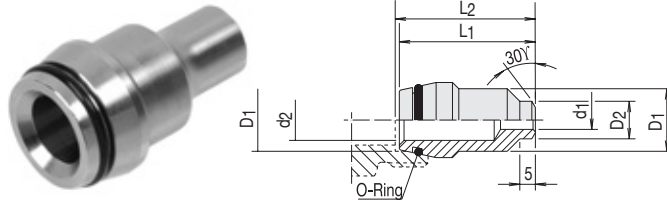

description	D1	D2	PN-V*	PB**	d ₁	d ₂	L ₁	L ₂	O-Ring	kg / 100 pcs
SNR 10/6x2	10	6	800	638	2	4	31.5	33.5	7.5x1.5	1.5
SNR 10/8x2.5	10	8	800	630	3	4	31.5	33.5	7.5x1.5	1.7
SNR 12/8x2.5	12	8	630	624	3	5	31.5	33.5	9 x1.5	2.0
SNR 12/10x3	12	10	630	624	4	5	31.5	33.5	9 x1.5	1.8
SNR 16/12x3.5	16	12	630	433	5	10	37.5	40.5	12 x2	4.3
SNR 20/12x3.5	20	12	400	458	5	12	43.5	47.0	16.3x2.4	8.0
SNR 20/16x3	20	16	400	433	10	12	43.5	47.0	16.3x2.4	7.8
SNR 25/16x3	25	16	400	433	10	15	49.5	53.5	20.3x2.4	12.3
SNR 25/20x4	25	20	400	458	12	15	49.5	53.5	20.3x2.4	12.4
SNR 30/16x3	30	16	400	433	10	18	52.0	57.5	25.3x2.4	16.5
SNR 30/20x4	30	20	400	458	12	18	52.0	57.5	25.3x2.4	15.9
SNR 30/25x5	30	25	400	458	15	18	52.0	57.5	25.3x2.4	14.4
SNR 38/16x3	38	16	400	433	10	22	56.5	64.5	33.3x2.4	27.9
SNR 38/20x4	38	20	400	458	12	22	56.5	64.5	33.3x2.4	27.8
SNR 38/25x5	38	25	400	458	15	22	56.5	64.5	33.3x2.4	26.2
SNR 38/30x4	38	30	400	321	22	22	56.5	64.5	33.3x2.4	25.2

* Rated Pressure (PN) for the equivalent fitting. S-series

** Maximum operating pressure (PB) for SNO and tube

Please see "Engineering and technical data - Selecting the correct tube fitting" for more information on pressure.

WELDING NIPPLE-PIPE SCREW JOINTS WELDING TYPE SCREW JOINTS

THE WORLD OF TUBE FITTINGS

SNO-V WELDING TYPE SCREW JOINT

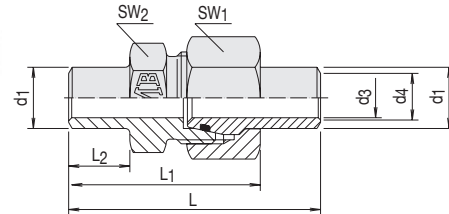

description	PB*	d ₁	d ₄	d ₃	SW ₂	SW ₁	L	L ₁	L ₂	kg / 100 pcs
SNO-V-10x1-S/SA	249	10	7	8	19	22	60.0	43.0	14	5.6
SNO-V-10x1.5-S/SA	358	10	7	7	19	22	60.0	43.0	14	7.3
SNO-V-10x2-S/SA	460	10	7	6	19	22	60.0	43.0	14	8.5
SNO-V-12x1.5-S/SA	305	12	8	9	22	24	62.0	45.5	14	7.4
SNO-V-12x2-S/SA	391	12	8	10	22	24	62.0	45.5	14	9.3
SNO-V-12x2.5-S/SA	474	12	8	7	22	24	62.0	45.5	14	10.8
SNO-V-16x1.5-S/SA	234	16	12	13	27	30	71.0	49.0	14	12.4
SNO-V-16x2-S/SA	303	16	12	12	27	30	71.0	49.0	14	14.3
SNO-V-16x2.5-S/SA	370	16	12	11	27	30	71.0	49.0	14	16.6
SNO-V-16x3-S/SA	433	16	12	10	27	30	71.0	49.0	14	19.1
SNO-V-20x2-S/SA	249	20	15	16	32	36	84.5	60.5	20	22.7
SNO-V-20x2.5-S/SA	305	20	15	15	32	36	84.5	60.5	20	23.9
SNO-V-20x3-S/SA	357	20	15	14	32	36	84.5	60.5	20	26.1
SNO-V-20x4-S/SA	400	20	15	12	32	36	84.5	60.5	20	32.3
SNO-V-25x3-S/SA	292	25	20	19	41	46	93.5	65.5	20	41.8
SNO-V-25x4-S/SA	378	25	20	17	41	46	93.5	65.5	20	55.5
SNO-V-25x5-S/SA	400	25	20	15	41	46	93.5	65.5	20	58.5
SNO-V-30x3-S/SA	249	30	25	24	46	50	98.0	68.5	20	59.4
SNO-V-30x4-S/SA	321	30	25	22	46	50	98.0	68.5	20	68.5
SNO-V-30x5-S/SA	391	30	25	20	46	50	98.0	68.5	20	73.3
SNO-V-30x6-S/SA	400	30	25	18	46	50	98.0	68.5	20	75.3
SNO-V-38x4-S/SA	260	38	32	30	55	60	107.5	75.0	20	82.0
SNO-V-38x5-S/SA	318	38	32	28	55	60	107.5	75.0	20	104.5
SNO-V-38x6-S/SA	373	38	32	26	55	60	107.5	75.0	20	111.0
SNO-V-38x7-S/SA	400	38	32	24	55	60	107.5	75.0	20	120.1

* Maximum operating pressure (PB) for SNO and tube

Please see "Engineering and technical data - Selecting the correct tube fitting" for more information on pressure.

WELDING NIPPLE-PIPE SCREW JOINTS

WELDING TYPE SCREW JOINTS

SNO-A ORDER EXAMPLE SCREW JOINT

SNO-A 25X3-RS/WD

SNO	Code for welding nipple (steel nipple O-ring)
A	Type of fitting
25	Outside pipe diameter
3	Wall thickness of welding nipple
R	Stud thread
S	Series
WD	Soft seal
xxx	Additional code



SNO-A 25X3-RS/WD/VIT/1.4571

SNO	Code for welding nipple (steel nipple O-ring)
A	Type of fitting
25	Outside pipe diameter
3	Wall thickness of welding nipple
R	Stud thread
S	Series
WD	Soft seal
VIT	Code Viton
1.4517	Code stainless steel

THE WORLD OF TUBE FITTINGS
INTEGRATED FLUID POWER SOLUTIONS



FLARE COUPLINGS



FLARE COUPLINGS

ABO FLARE CONNECTION PARTS

THE WORLD OF TUBE FITTINGS

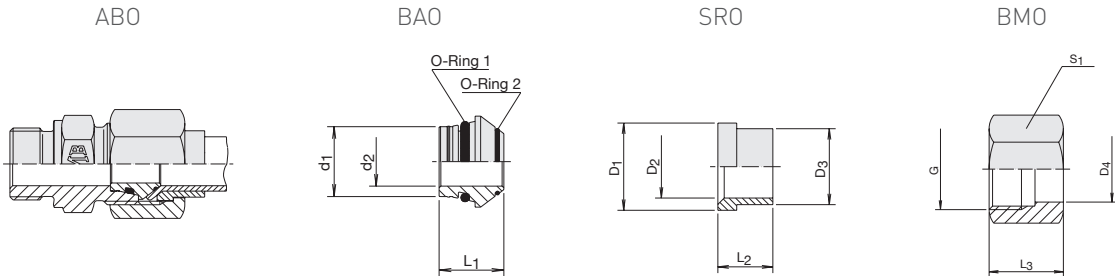

FLARE CONNECTION PARTS

BAO supplied with NBR O-rings (e.g. Perbunan), FKM O-rings (e.g. Viton) upon request.

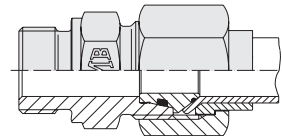

description	flare adaptor	support ring	nut
ABO 6-L	BAO 6-L/S	SRO 6-L/S	BM0-6L
ABO 8-L	BAO 8-L/S	SRO 8-L/S	BM0-8L
ABO 10-L	BAO 10-L/S	SRO 10-L/S	BM0-10L
ABO 12-L	BAO 12-L/S	SRO 12-L/S	BM0-12L
ABO 15-L	BAO 15-L	SRO 15-L	BM0-15L
ABO 18-L	BAO 18-L	SRO 18-L	BM0-18L
ABO 22-L	BAO 22-L	SRO 22-L	BM0-22L
ABO 28-L	BAO 28-L	SRO 28-L	BM0-28L
ABO 35-L	BAO 35-L	SRO 35-L	BM0-35L
ABO 42-L	BAO 42-L	SRO 42-L	BM0-42L
ABO 6-S	BAO 6-L/S	SRO 6-L/S	BM0-6S
ABO 8-S	BAO 8-L/S	SRO 8-L/S	BM0-8S
ABO 10-S	BAO 10-L/S	SRO 10-L/S	BM0-10S
ABO 12-S	BAO 12-L/S	SRO 12-L/S	BM0-12S
ABO 14-S	BAO 14-S	SRO 14-S	BM0-14S
ABO 16-S	BAO 16-S	SRO 16-S	BM0-16S
ABO 20-S	BAO 20-S	SRO 20-S	BM0-20S
ABO 25-S	BAO 25-S	SRO 25-S	BM0-25S
ABO 30-S	BAO 30-S	SRO 30-S	BM0-30S
ABO 38-S	BAO 38-S	SRO 38-S	BM0-38S

Please see "Engineering and technical data – Selecting the correct tube fitting" for functional characteristics, tube length determination and assembly instructions.

FLARE COUPLINGS

ABO FLARE CONNECTION PARTS

description	PN series	Tube OD	d ₁	d ₂	L ₁	O-Ring 1	O-Ring 2
BAO 6-L/S	L500	6	6	3	11.5	4x1.5	4.4x0.8
BAO 8-L/S	L500	8	8	5	12.0	6x1.5	6x0.8
BAO 10-L/S	L500	10	10	6	12.5	7.5x1.5	7.5x0.8
BAO 12-L/S	L400	12	12	8	12.5	9x1.5	9.5x0.8
BAO 15-L	L400	15	15	11	12.5	12x2	12.5x0.8
BAO 18-L	L400	18	18	14	13.0	15x2	15x1
BAO 22-L	L250	22	22	17	14.2	20x2	18x1
BAO 28-L	L250	28	28	23	14.7	26x2	23x1
BAO 35-L	L250	35	35	28	18.5	32x2.5	30x1
BAO 42-L	L250	42	42	35	20.5	38x2.5	36.5x1
BAO 6-L/S	S630	6	6	3	11.5	4x1.5	4.4x0.8
BAO 8-L/S	S630	8	8	5	12.0	6x1.5	6x0.8
BAO 10-L/S	S630	10	10	6	12.5	7.5x1.5	7.5x0.8
BAO 12-L/S	S630	12	12	8	12.5	9x1.5	9.5x0.8
BAO 14-S	S630	14	14	9	14.0	10x2	11x1
BAO 16-S	S630	16	16	11	15.0	12x2	12.5x1
BAO 20-S	S400	20	20	14	18.5	16.3x2.4	16x1
BAO 25-S	S400	25	25	19	20.0	20.3x2.4	20x1
BAO 30-S	S400	30	30	23	22.0	25.3x2.4	25x1
BAO 38-S	S400	38	38	30	26.0	33.3x2.4	31.47x1.78

description	PN series	Tube OD	D ₁	D ₂	D ₃	L ₂
SRO 6-L/S	L500	6	10.2	6	7.6	10.5
SRO 8-L/S	L500	8	12.2	8	9.3	11.0
SRO 10-L/S	L500	10	14.2	10	11.5	12.5
SRO 12-L/S	L400	12	16.2	12	13.6	13.0
SRO 15-L	L400	15	20.2	15	17.5	14.0
SRO 18-L	L400	18	24.2	18	21.0	14.5
SRO 22-L	L250	22	27.8	22	24.2	18.0
SRO 28-L	L250	28	33.8	28	30.2	17.0
SRO 35-L	L250	35	42.7	35	38.0	19.0
SRO 42-L	L250	42	49.7	42	45.0	21.0
SRO 6-L/S	S630	6	10.2	6	7.6	10.5
SRO 8-L/S	S630	8	12.2	8	9.3	11.0
SRO 10-L/S	S630	10	14.2	10	11.5	12.5
SRO 12-L/S	S630	12	16.2	12	13.6	13.0
SRO 14-S	S630	14	20.2	14	17.5	14.5
SRO 16-S	S630	16	22.0	16	18.5	17.0
SRO 20-S	S400	20	27.8	20	24.2	17.5
SRO 25-S	S400	25	32.8	25	28.5	20.0
SRO 30-S	S400	30	39.0	30	34.0	21.5
SRO 38-S	S400	38	48.5	38	42.0	26.5

description	thread	D ₄	L ₃	S ₁
BMO-6L	12x1.5	7.8	17.0	14
BMO-8L	14x1.5	9.5	18.0	17
BMO-10L	16x1.5	11.7	19.5	19
BMO-12L	18x1.5	13.8	20.5	22
BMO-15L	22x1.5	17.7	23.0	27
BMO-18L	26x1.5	21.2	23.0	32
BMO-22L	30x2	24.4	27.5	36
BMO-28L	36x2	30.4	27.5	41
BMO-35L	45x2	38.3	30.0	50
BMO-42L	52x2	45.3	34.0	60
BMO-6S	14x1.5	7.8	18.0	17
BMO-8S	16x1.5	9.5	19.0	19
BMO-10S	18x1.5	11.7	20.5	22
BMO-12S	20x1.5	13.8	21.0	24
BMO-14S	22x1.5	17.7	23.0	27
BMO-16S	24x1.5	18.7	26.5	30
BMO-20S	30x2	24.4	27.5	36
BMO-25S	36x2	28.7	30.5	46
BMO-30S	42x2	34.2	32.0	50
BMO-38S	52x2	42.3	38.0	60

Please see "Engineering and technical data – Selecting the correct tube fitting" for functional characteristics, tube length determination and assembly instructions.

FLARE COUPLINGS

ABO FLARE CONNECTION PARTS

THE WORLD OF TUBE FITTINGS

ABO-A ORDER EXAMPLE SCREW JOINT

If ordering complete fittings with flare connection parts, add the letters ABO to the normal Order No.

ABO-A 20-RS

ABO	Code for flare coupling
A	Type of fitting
20	Outside pipe diameter
R	Stud thread
S	Series

ABO -A 20-RS/VIT/1.4571

ABO	Code for welding nipple (steel nipple O-ring)
A	Type of fitting
20	Outside pipe diameter
R	Stud thread
S	Series
VIT	Code Viton
1.4517	Code stainless steel



Please see "Engineering and technical data – Selecting the correct tube fitting" for functional characteristics, tube length determination and assembly instructions.

THE WORLD OF TUBE FITTINGS
INTEGRATED FLUID POWER SOLUTIONS



CONTROL SYSTEM



CONTROL SYSTEM

CST CONNECT TEST SYSTEM WITH PIN LOCK 400 BAR

THE WORLD OF TUBE FITTINGS

CST SYSTEM INTRODUCTION

CST APPLICATION

- › Fast coupling for monitoring and control of pressure.
- › Venting and sampling in high, low and vacuum systems up to 400 bar.

CST ADVANTAGES

- › Coupling at system pressure level.
- › Leak proof connection before ball valve is open.
- › Simple connection with measuring, control and switching devices.

CST MATERIALS

- › Metal parts: Steel, Stainless Steel on request.
- › Ball: Stainless Steel.
- › Seals (add the letter to the description):
 - P = Buna N (Temperature range -20°C to +100°C).
 - VIT = Viton (Temperature range -20°C to +200°C).
 - E = Ethylene Propylene on request (for brake fluid).
- › Hose: Polyamide (+100°C maximum).
- › Data in this catalogue is according to technical standard current at the time of printing and is subject to change without notification.

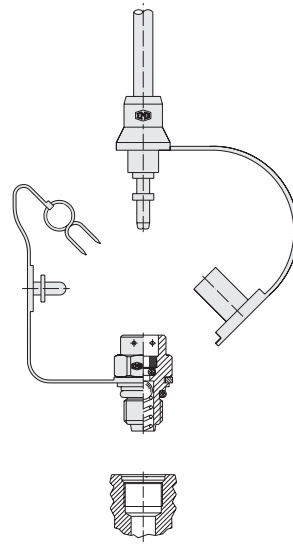

CONTROL SYSTEM CST CONNECT TEST SYSTEM WITH PIN LOCK 400 BAR

CST CONNECT TEST SYSTEM WITH PIN LOCK

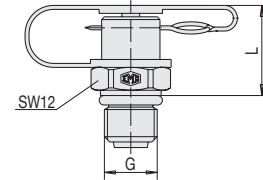

description	PN	G	L	Seal
CST M 8 x 1	250	M 8 x 1	18	O-Ring
CST M 10 x 1	400	M 10 x 1	18	O-Ring
CST R 1/8" K	400	R 1/8"	18	Taper Form D

Please see "Engineering and technical data - Selecting the correct tube fitting" for more information on port connections and seals.

CST PRESSURE GAUGE FITTING WITH PIN LOCK

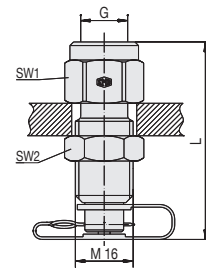

description	G	L	SW1	SW2
CSTO-G 1/4"	G 1/4"	66	19	19
CSTO-G 1/2"	G 1/2"	75	27	24
CSTO-1/4 NPT	1/4 NPT	68	19	19
CSTO-1/2 NPT	1/2 NPT	75	27	24

Please see "Engineering and technical data - Selecting the correct tube fitting" for more information on port connections and seals.

CONTROL SYSTEM CST CONNECT TEST SYSTEM WITH PIN LOCK 400 BAR

THE WORLD OF TUBE FITTINGS

CST TEST COUPLING FOR CUTTING RING CONNECTION E

Test coupling with straight connection.

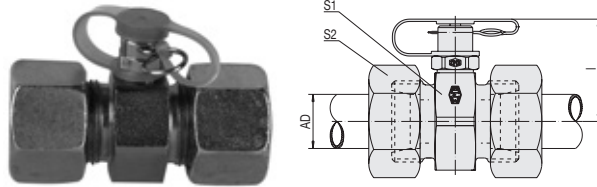

description	PN series	pipe OD	l	SW1	SW2
DS-CSTE 6-L	L 315	6	29.0	22	14
DS-CSTE 8-L	L 315	8	30.0	24	17
DS-CSTE 10-L	L 315	10	30.0	24	19
DS-CSTE 12-L	L 315	12	32.0	27	22
DS-CSTE 15-L	L 315	15	33.0	30	27
DS-CSTE 18-L	L 315	18	34.0	32	32
DS-CSTE 22-L	L 160	22	36.0	36	36
DS-CSTE 28-L	L 160	28	39.0	41	41
DS-CSTE 35-L	L 160	35	41.0	46	50
DS-CSTE 42-L	L 160	42	46.0	55	60
DS-CSTE 6-S	S 630	6	30.0	24	17
DS-CSTE 8-S	S 630	8	30.0	24	19
DS-CSTE 10-S	S 630	10	30.0	24	22
DS-CSTE 12-S	S 630	12	30.0	24	24
DS-CSTE 14-S	S 630	14	32.0	27	27
DS-CSTE 16-S	S 400	16	33.0	30	30
DS-CSTE 20-S	S 400	20	34.0	32	36
DS-CSTE 25-S	S 400	25	38.5	41	46
DS-CSTE 30-S	S 400	30	41.0	46	50
DS-CSTE 38-S	S 315	38	46.0	55	60

CONTROL SYSTEM CST CONNECT TEST SYSTEM WITH PIN LOCK 400 BAR

CST TEST COUPLING FOR CUTTING RING CONNECTION S

Test coupling with taper and O-ring.

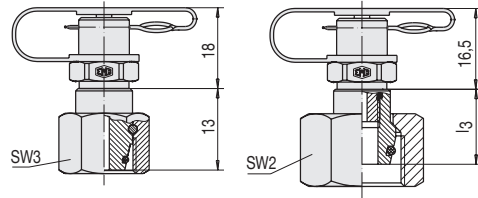

description	PN series	pipe OD	l_3	SW2/3
CSTS 6-L	L 315	6	33.0	14
CSTS 8-L	L 315	8	33.0	17
CSTS 10-L	L 315	10	33.0	19
CSTS 12-L	L 315	12	33.0	22
CSTS 15-L	L 315	15	20.0	27
CSTS 18-L	L 315	18	22.0	32
CSTS 22-L	L 160	22	22.0	36
CSTS 28-L	L 160	28	24.0	41
CSTS 35-L	L 160	35	27.0	50
CSTS 42-L	L 160	42	28.0	60
CSTS 6-S	S 630	6	34.0	17
CSTS 8-S	S 630	8	34.0	19
CSTS 10-S	S 630	10	34.0	22
CSTS 12-S	S 630	12	34.0	24
CSTS 14-S	S 630	14	20.0	27
CSTS 16-S	S 400	16	20.0	30
CSTS 20-S	S 400	20	25.0	36
CSTS 25-S	S 400	25	27.0	46
CSTS 30-S	S 400	30	29.0	50
CSTS 38-S	S 315	38	32.0	60

CONTROL SYSTEM

CSH TEST COUPLING WITH SCREW LOCK 630 BAR

THE WORLD OF TUBE FITTINGS

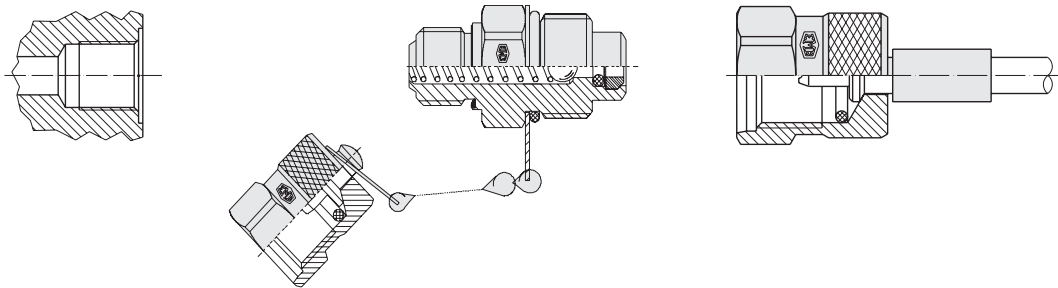

CSH SYSTEM INTRODUCTION

CSH APPLICATION

- › Monitoring and control of pressure.
- › Venting and sampling in high, low and vacuum systems up to 630 bar working pressure.
- › Connecting under pressure up to 400 bar.

CSH ADVANTAGES

- › Coupling at system pressure level.
- › Leak proof connection before ball valve is open.
- › Simple connection with measuring, control and switching devices.
- › Self-locking metal guard cap.

CSH MATERIALS

- › Metal parts: Steel, Stainless Steel on request.
- › Ball: Stainless Steel.
- › Seals (add the letter to the description):
 - P = Buna N (Temperature range -20°C to +100°C).
 - VIT = Viton (Temperature range -20°C to +200°C).
 - E = Ethylene Propylene on request (for brake fluid).
- › Data in this catalogue is according to technical standard current at the time of printing and is subject to change without notification.

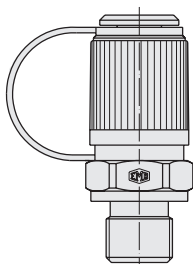

The complete CSH range is available with hexagonal plastic caps

CONTROL SYSTEM

CSH TEST COUPLING WITH SCREW LOCK 630 BAR

CSH TEST COUPLING WITH SCREW LOCK

Type series M16x2.

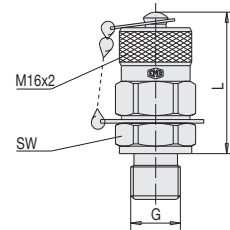

description	G	L	SW	sealing
CSH M 8 x 1	M 8 x 1	38	17	O-Ring Form A
CSH M 10 x 1	M 10 x 1	38	17	O-Ring Form A
CSH M 12 x 1.5/WD	M 12 x 1.5	39	17	WD Form C
CSH M 14 x 1.5	M 14 x 1.5	37	19	Metaljoint Form B
CSH M 16 x 1.5	M 16 x 1.5	37	22	Metaljoint Form B
CSH R 1/8"	R 1/8"	38	17	Metaljoint Form B
CSH R 1/8"/WD	R 1/8"	39	17	WD Form C
CSH R 1/8" K	R 1/8" K	36	17	Taper Form D
CSH R 1/4"	R 1/4"	37	19	Metaljoint Form B
CSH R 1/4"/WD	R 1/4"	37	19	WD Form C
CSH R 1/4" K	R 1/4" K	35	17	Taper Form D
CSH R 3/8"	R 3/8"	37	22	Metaljoint Form B
CSH R 3/8"/WD	R 3/8"	37	22	WD Form C
CSH 1/8" NPT	1/8" NPT	36	17	Taper Form D
CSH 1/4" NPT	1/4" NPT	35	17	Taper Form D
CSH 5/16" UNF	5/16"-24 UNF	38	17	O-Ring Form E
CSH 1/2" UNF	1/2"-20 UNF	38	17	O-Ring Form E
CSH 7/16" UNF	7/16"-20 UNF	38	17	O-Ring Form E
CSH 9/16" UNF	9/16"-18 UNF	38	19	O-Ring Form E

Please see "Engineering and technical data - Selecting the correct tube fitting" for more information on port connections and seals.

CONTROL SYSTEM CSH TEST COUPLING WITH SCREW LOCK 630 BAR

THE WORLD OF TUBE FITTINGS

CSH TEST COUPLING FOR CUTTING RING CONNECTION E

Test coupling with straight connection.

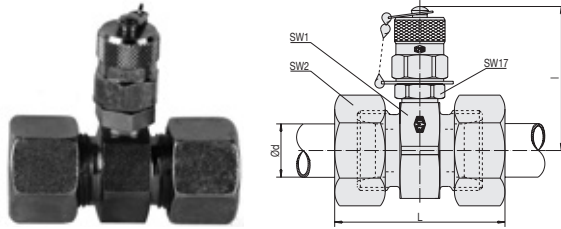

description	PN series	pipe OD	l	SW1	SW2
DS-CSHE 6-L	L 315	6	48.0	22	14
DS-CSHE 8-L	L 315	8	49.0	24	17
DS-CSHE 10-L	L 315	10	49.0	24	19
DS-CSHE 12-L	L 315	12	51.0	27	22
DS-CSHE 15-L	L 315	15	53.0	30	27
DS-CSHE 18-L	L 315	18	53.0	32	32
DS-CSHE 22-L	L 160	22	55.0	36	36
DS-CSHE 28-L	L 160	28	58.0	41	41
DS-CSHE 35-L	L 160	35	60.0	46	50
DS-CSHE 42-L	L 160	42	65.0	55	60
DS-CSHE 6-S	S 630	6	49.0	24	17
DS-CSHE 8-S	S 630	8	49.0	24	19
DS-CSHE 10-S	S 630	10	49.0	24	22
DS-CSHE 12-S	S 630	12	49.0	24	24
DS-CSHE 14-S	S 630	14	51.0	27	27
DS-CSHE 16-S	S 400	16	52.0	30	30
DS-CSHE 20-S	S 400	20	53.0	32	36
DS-CSHE 25-S	S 400	25	58.0	41	46
DS-CSHE 30-S	S 400	30	60.0	46	50
DS-CSHE 38-S	S 315	38	65.0	55	60

CONTROL SYSTEM

CSH TEST COUPLING WITH SCREW LOCK 630 BAR

CSH TEST COUPLING FOR CUTTING RING CONNECTION S

Test coupling with taper and O-ring.

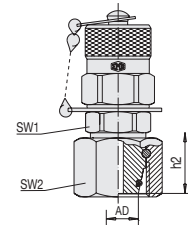

description	PN series	pipe OD	h_1	h_2	SW1	SW2
CSHS 6-L	L 315	6	53		14	17
CSHS 8-L	L 315	8	53		17	17
CSHS 10-L	L 315	10	50		19	17
CSHS 12-L	L 315	12	50		22	17
CSHS 15-L	L 315	15	51		27	19
CSHS 18-L	L 315	18		22	32	
CSHS 22-L	L 160	22		22	36	
CSHS 28-L	L 160	28		24	41	
CSHS 35-L	L 160	35		27	50	
CSHS 42-L	L 160	42		28	60	
CSHS 6-S	S 630	6	54		17	17
CSHS 8-S	S 630	8	51		19	17
CSHS 10-S	S 630	10	51		22	17
CSHS 12-S	S 630	12	51		24	17
CSHS 14-S	S 630	14	53		27	19
CSHS 16-S	S 400	16		20	30	
CSHS 20-S	S 400	20		25	36	
CSHS 25-S	S 400	25		27	46	
CSHS 30-S	S 400	30		29	50	
CSHS 38-S	S 315	38		32	60	

CONTROL SYSTEM

CSH TEST COUPLING WITH SCREW LOCK 630 BAR

THE WORLD OF TUBE FITTINGS

CSH DIRECT GAUGE ADAPTOR

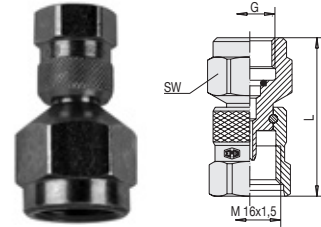

description	G	L	SW
CSHD-G 1/4	G 1/4	54	19
CSHD-G 1/2	G 1/2	58	27
CSHD-1/4 NPT	1/4 NPT	53	19
CSHD-1/2 NPT	1/2 NPT	59	27

CSH GAUGE ADAPTOR

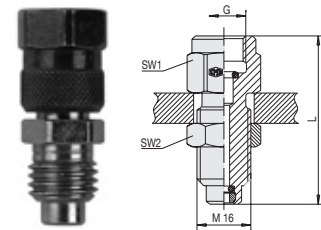

description	G	L	SW1	SW2
CSHO-R 1/4"	R 1/4	57	19	19
CSHO-R 1/2"	R 1/2	66	27	24

CONTROL SYSTEM

CSH TEST COUPLING WITH SCREW LOCK 630 BAR

CSH REDUCING FITTING

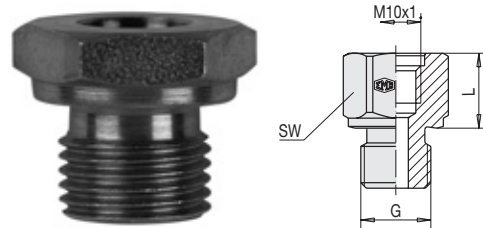

description	G	L	SW	sealing
CSH-RS-M 16 x 1.5	M 16 x 1.5	18	22	Metaljoint Form B
CSH-RS-G 1/8	G 1/8	19	14	Metaljoint Form B
CSH-RS-G 3/8	G 3/8	18	22	Metaljoint Form B
CSH-RS-G 1/2	G 1/2	10	27	Metaljoint Form B
CSH-RS-R 1/4 K	R 1/4 kegelig	17	19	Tape Form D

CSH BULKHEAD COUPLING A

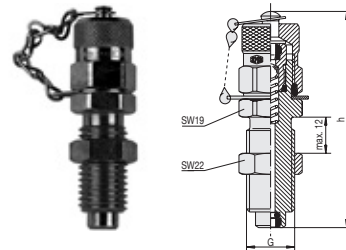

description	form	G	h	SW
CSH SK	A	M 16 x 2	72	19

CSH BULKHEAD COUPLING B

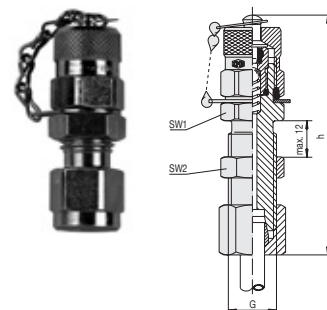

description	form	G	h		SW1	SW2
CSH SK 8-S	B	M 16 x 1.5*	72	compression ring assembly 8 S/12 L acc. to DIN 2353	22	22
CSH SK 12-L	B	M 18 x 1.5*	72	compression ring assembly 8 S/12 L acc. to DIN 2353	22	22

CONTROL SYSTEM

CSH TEST COUPLING WITH SCREW LOCK 630 BAR

THE WORLD OF TUBE FITTINGS

CSH THREAD TYPE ADAPTOR A

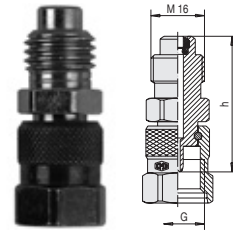

description	form	G1	G2	h1	h2	SW1	
CSAD/CSH-CSS	A	M 16 x 2	M 16 x 1.5	39	56	17	
CSAD/CSH-CS 12	A	M 16 x 2	S 12x1.5	39	50	17	butress thread S 12.65 x 1.5

CSH THREAD TYPE ADAPTOR B

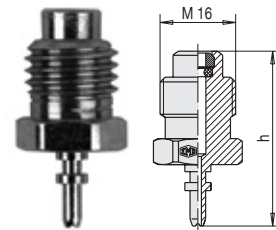

description	form	G	h
CSAD/CSH-CST	B	CST	37.5

CSH WELDING ADAPTOR

Material: St 37.

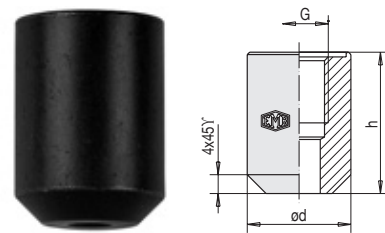

description	OD	G	h
CSAS-M 10 x 1	20	M 10 x 1	25
CSAS-G 1/4"	22	G 1/4"	30

CONTROL SYSTEM

CSS TEST COUPLING WITH SCREW LOCK 630 BAR

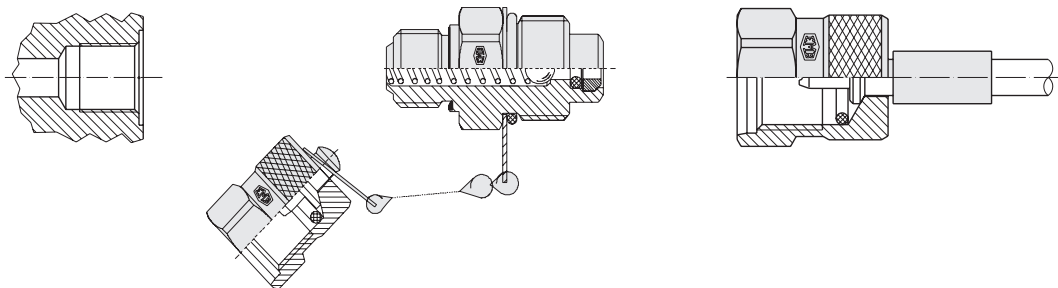

CSS SYSTEM INTRODUCTION

CSS APPLICATION

- › Monitoring and control of pressure.
- › Venting and sampling in high, low and vacuum systems up to 630 bar working pressure.

CSS ADVANTAGES

- › Coupling at system pressure level.
- › Leak proof connection before ball valve is open.
- › Simple connection with measuring, control and switching devices.
- › Self-locking metal guard cap.

CSS MATERIALS

- › Metal parts: Steel, Stainless Steel on request.
- › Ball: Stainless Steel.
- › Seals (add the letter to the description):
 - P = Buna N (Temperature range -20°C to +90°C).
 - VIT = Viton (Temperature range -20°C to +200°C).
 - E = Ethylene Propylene on request (for brake fluid).
- › Data in this catalogue is according to technical standard current at the time of printing and is subject to change without notification.

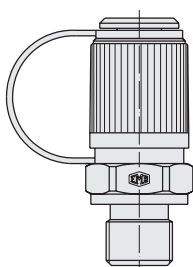

The complete CSS range is available with hexagonal steel or plastic caps

CONTROL SYSTEM

CSS TEST COUPLING WITH SCREW LOCK 630 BAR

THE WORLD OF TUBE FITTINGS

CSS TEST COUPLING WITH SCREW LOCK

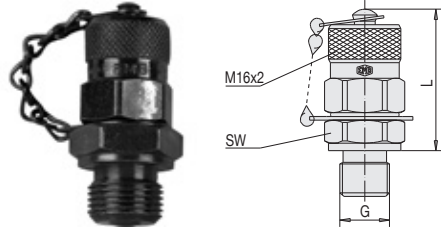

description	G	L	SW	sealing
CSS M 10 x 1	M 10 x 1	38	17	O-Ring Form A
CSS M 14 x 1.5	M 14 x 1.5	37	19	Metaljoint Form B
CSS M 16 x 1.5	M 16 x 1.5	37	22	Metaljoint Form B
CSS R 1/4"	R 1/4"	37	19	Metaljoint Form B
CSS R 1/4"/WD	R 1/4"	37	19	WD Form C
CSS R 1/4" K	R 1/4" K	35	17	Taper Form D
CSS R 3/8"	R 3/8"	37	22	Metaljoint Form B
CSS 1/4" NPT	1/4" NPT	35	17	Taper Form D
CSS 9/16" UNF	9/16"-18 UNF	38	19	O-Ring Form E

Please see "Engineering and technical data - Selecting the correct tube fitting" for more information on port connections and seals.

CONTROL SYSTEM

CSS TEST COUPLING WITH SCREW LOCK 630 BAR

CSS TEST COUPLING FOR CUTTING RING CONNECTION E

Model E: Test coupling with straight coupling.

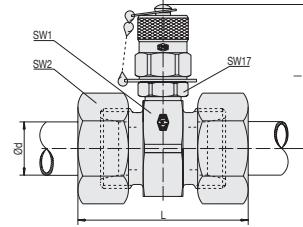

description	PN series	pipe OD	l	SW1	SW2
DS-CSSE 6-L	L 315	6	48.0	22	14
DS-CSSE 8-L	L 315	8	49.0	24	17
DS-CSSE 10-L	L 315	10	49.0	24	19
DS-CSSE 12-L	L 315	12	51.0	27	22
DS-CSSE 15-L	L 315	15	53.0	30	27
DS-CSSE 18-L	L 315	18	53.0	32	32
DS-CSSE 22-L	L 160	22	55.0	36	36
DS-CSSE 28-L	L 160	28	57.5	41	41
DS-CSSE 35-L	L 160	35	60.0	46	50
DS-CSSE 42-L	L 160	42	65.0	55	60
DS-CSSE 6-S	S 630	6	49.0	24	17
DS-CSSE 8-S	S 630	8	49.0	24	19
DS-CSSE 10-S	S 630	10	49.0	24	22
DS-CSSE 12-S	S 630	12	49.0	24	24
DS-CSSE 14-S	S 630	14	51.0	27	27
DS-CSSE 16-S	S 400	16	52.0	30	30
DS-CSSE 20-S	S 400	20	53.0	32	36
DS-CSSE 25-S	S 400	25	58.0	41	46
DS-CSSE 30-S	S 400	30	60.0	46	50
DS-CSSE 38-S	S 315	38	65.0	55	60

CONTROL SYSTEM

CSS TEST COUPLING WITH SCREW LOCK 630 BAR

THE WORLD OF TUBE FITTINGS

CSS TEST COUPLING FOR CUTTING RING CONNECTION S

Model S: Test coupling with taper and O-ring.

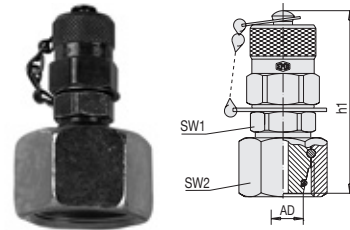

description	PN series	pipe OD	h ₁	h ₂	SW1	SW2
CSSS 6-L	L 315	6	53		14	17
CSSS 8-L	L 315	8	53		17	17
CSSS 10-L	L 315	10	50		19	17
CSSS 12-L	L 315	12	50		22	17
CSSS 15-L	L 315	15	51		27	19
CSSS 18-L	L 315	18		22	32	
CSSS 22-L	L 160	22		22	36	
CSSS 28-L	L 160	28		24	41	
CSSS 35-L	L 160	35		27	50	
CSSS 42-L	L 160	42		28	60	
CSSS 6-S	S 630	6	54		17	17
CSSS 8-S	S 630	8	51		19	17
CSSS 10-S	S 630	10	51		22	17
CSSS 12-S	S 630	12	51		24	17
CSSS 14-S	S 630	14		20	27	19
CSSS 16-S	S 400	16		20	30	
CSSS 20-S	S 400	20		25	36	
CSSS 25-S	S 400	25		27	46	
CSSS 30-S	S 400	30		29	50	
CSSS 38-S	S 315	38		32	60	

CSS DIRECT GAUGE ADAPTOR

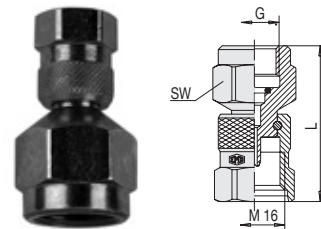

description	G	L	SW
CSSD-G 1/4	G 1/4	54	19
CSSD-G 1/2	G 1/2	58	27
CSSD-1/4 NPT	1/4 NPT	53	19
CSSD-1/2 NPT	1/2 NPT	61	27

CONTROL SYSTEM

CSS TEST COUPLING WITH SCREW LOCK 630 BAR

CSS GAUGE ADAPTOR

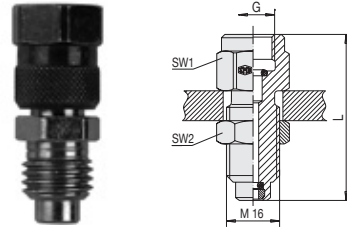

description	G	L	SW1	SW2
CSS0-R 1/4"	G 1/4	57	19	19
CSS0-R 1/2"	G 1/2	66	27	19
CSS0-1/4 NPT	1/4 NPT	55	19	19
CSS0-1/2 NPT	1/2 NPT	64	27	19

CSS REDUCING FITTING

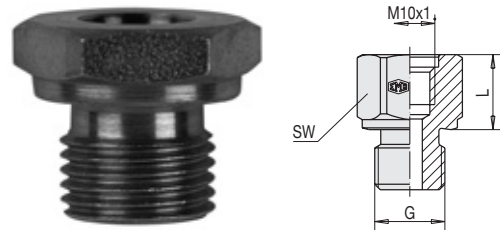

description	G	L	SW	sealing
CSS-RS-M 18 x 1.5	M 18 x 1.5	10	24	Metaljoint Form B
CSS-RS-M 20 x 1.5	M 20 x 1.5	10	27	Metaljoint Form B
CSS-RS-G 3/8	G 3/8	18	22	Metaljoint Form B
CSS-RS-G 1/2	G 1/2	18	27	Metaljoint Form B

CONTROL SYSTEM

CSS TEST COUPLING WITH SCREW LOCK 630 BAR

THE WORLD OF TUBE FITTINGS

CSS BULKHEAD COUPLING A

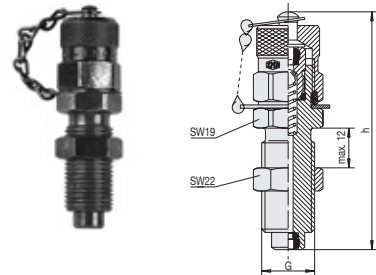

description	G	h	form	SW
CSS SK	M 16 x 2	72	A	19

CSS BULKHEAD COUPLING B

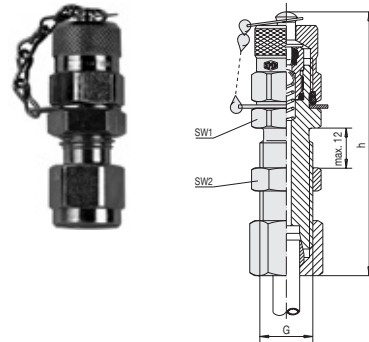

description	G	h	form	SW1	SW2
CSS SK 8-S	M 16 x 1.51]	74	B	22	22

CONTROL SYSTEM

CSS TEST COUPLING WITH SCREW LOCK 630 BAR

CSS THREAD TYPE ADAPTOR A

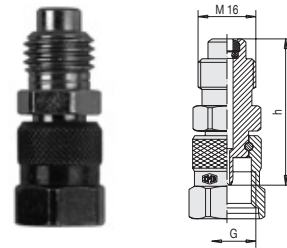

description	G	h	form
CSAD/CSS-CSH	M 16 x 2	39	A
CSAD/CSS-CS 12	S12*	39	A

* Special thread S 12,65 x 1,5

CSS THREAD TYPE ADAPTOR B

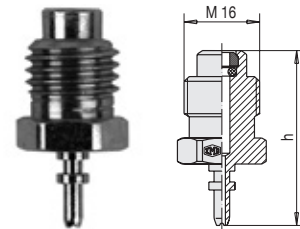

description	G	h	form
CSAD/CSS-CST	CST	37.5	B

CSS WELDING ADAPTOR

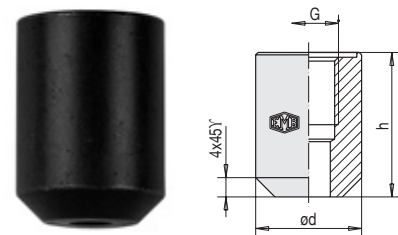

description	OD	G	h
CSAS-M 10 x 1	20	M 10 x 1	25
CSAS-G 1/4"	22	G 1/4"	30

CONTROL SYSTEM

CSHK TEST COUPLING WITH SCREW LOCK 630 BAR

THE WORLD OF TUBE FITTINGS

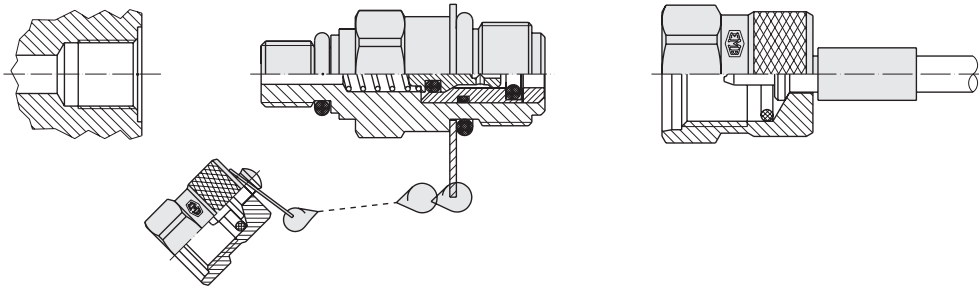

CSHK SYSTEM INTRODUCTION

CSHK APPLICATION

- › Monitoring and control of pressure.
- › Venting and sampling in high, low and vacuum systems up to 630 bar working pressure.
- › Connecting under pressure up to 400 bar.

CSHK ADVANTAGES

- › Coupling at system pressure level.
- › Leak proof connection before ball valve is open.
- › Simple connection with measuring, control and switching devices.
- › Self-locking metal guard cap.

CSHK MATERIALS

- › Metal parts: Steel, Stainless Steel on request.
- › Ball: Stainless Steel.
- › Seals (add the letter to the description):
 - P = Buna N (Temperature range -20°C to +90°C).
 - VIT = Viton (Temperature range -20°C to +200°C).
 - E = Ethylene Propylene on request (for brake fluid).
- › Data in this catalogue is according to technical standard current at the time of printing and is subject to change without notification.

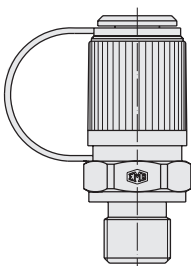

The complete CSHK range is available with hexagonal steel or plastic caps

CONTROL SYSTEM

CSHK TEST COUPLING WITH SCREW LOCK 630 BAR

CSHK TEST COUPLING WITH SCREW LOCK

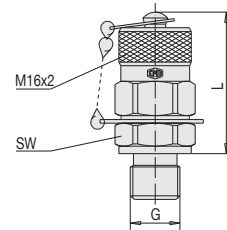

description	G	L	SW	sealing
CSHK M 8 x 1	M 8 x 1	38	17	O-Ring Form A
CSHK M 10 x 1	M 10 x 1	38	17	O-Ring Form A
CSHK M 12 x 1.5/WD	M 12 x 1.5	39	17	WD Form C
CSHK M 14 x 1.5	M 14 x 1.5	37	19	Metaljoint Form B
CSHK M 16 x 1.5	M 16 x 1.5	37	22	Metaljoint Form B
CSHK R 1/8"/WD	R 1/8"	39	17	WD Form C
CSHK R 1/8" K	R 1/8" K	36	17	Taper Form D
CSHK R 1/4"	R 1/4"	37	19	Metaljoint Form B
CSHK R 1/4"/WD	R 1/4"	37	19	WD Form C
CSHK R 1/4" K	R 1/4" K	35	17	Taper Form D
CSHK R 3/8"	R 3/8"	37	22	Metaljoint Form B
CSHK 1/8" NPT	1/8" NPT	36	17	Taper Form D
CSHK 1/4" NPT	1/4" NPT	35	17	Taper Form D
CSHK 5/16" UNF	5/16"-24 UNF	38	17	O-Ring Form E
CSHK 1/2" UNF	1/2"-20 UNF	38	17	O-Ring Form E
CSHK 7/16" UNF	7/16"-20 UNF	38	17	O-Ring Form E
CSHK 9/16" UNF	9/16"-18 UNF	38	19	O-Ring Form E

Please see "Engineering and technical data - Selecting the correct tube fitting" for more information on port connections and seals.

CONTROL SYSTEM

CSHK TEST COUPLING WITH SCREW LOCK 630 BAR

THE WORLD OF TUBE FITTINGS

CSHK TEST COUPLING FOR CUTTING RING CONNECTION E

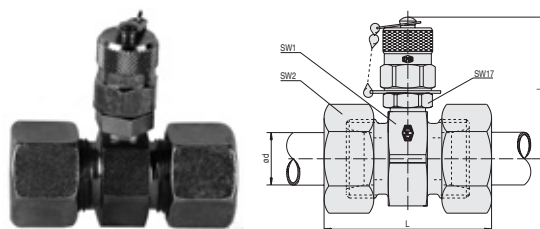

description	PN series	pipe OD	L	SW1	SW2
DS-CSHKE 6-L	L 315	6	48.0	22	14
DS-CSHKE 8-L	L 315	8	49.0	24	17
DS-CSHKE 10-L	L 315	10	49.0	24	19
DS-CSHKE 12-L	L 315	12	51.0	27	22
DS-CSHKE 15-L	L 315	15	53.0	30	27
DS-CSHKE 18-L	L 315	18	53.0	32	32
DS-CSHKE 22-L	L 160	22	55.0	36	36
DS-CSHKE 28-L	L 160	28	58.0	41	41
DS-CSHKE 35-L	L 160	35	60.0	46	50
DS-CSHKE 42-L	L 160	42	65.0	55	60
DS-CSHKE 6-S	S 630	6	49.0	24	17
DS-CSHKE 8-S	S 630	8	49.0	24	19
DS-CSHKE 10-S	S 630	10	49.0	24	22
DS-CSHKE 12-S	S 630	12	49.0	24	24
DS-CSHKE 14-S	S 630	14	51.0	27	27
DS-CSHKE 16-S	S 400	16	52.0	30	30
DS-CSHKE 20-S	S 400	20	53.0	32	36
DS-CSHKE 25-S	S 400	25	58.0	41	46
DS-CSHKE 30-S	S 400	30	60.0	46	50
DS-CSHKE 38-S	S 315	38	65.0	55	60

CONTROL SYSTEM

CSHK TEST COUPLING WITH SCREW LOCK 630 BAR

CSHK TEST COUPLING FOR CUTTING RING CONNECTION S

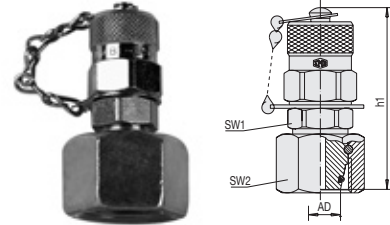

description	PN series	pipe OD	h_1	h_2	SW1	SW2
CSHKS 6-L	L 315	6	53		14	17
CSHKS 8-L	L 315	8	53		17	17
CSHKS 10-L	L 315	10	50		19	17
CSHKS 12-L	L 315	12	50		22	17
CSHKS 15-L	L 315	15	51		27	19
CSHKS 18-L	L 315	18		22	32	
CSHKS 22-L	L 160	22		22	36	
CSHKS 28-L	L 160	28		24	41	
CSHKS 35-L	L 160	35		27	50	
CSHKS 42-L	L 160	42		28	60	
CSHKS 6-S	S 630	6	54		17	17
CSHKS 8-S	S 630	8	51		19	17
CSHKS 10-S	S 630	10	51		22	17
CSHKS 12-S	S 630	12	51		24	17
CSHKS 14-S	S 630	14		24	27	19
CSHKS 16-S	S 400	16		20	30	
CSHKS 20-S	S 400	20		25	36	
CSHKS 25-S	S 400	25		27	46	
CSHKS 30-S	S 400	30		29	50	
CSHKS 38-S	S 315	38		32	60	

CONTROL SYSTEM PRESSURE TEST KIT

THE WORLD OF TUBE FITTINGS



CST 1, 2, 3
CSH 1, 2, 3
CSS 1, 2, 3

Bespoke complement on customer's request.

CONTROL SYSTEM PRESSURE GAUGE

CMM PRESSURE GAUGE

Glycerin filled.

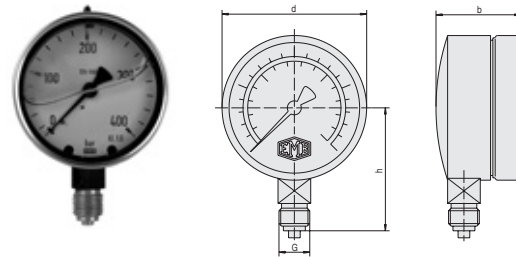

description		pressure range				
G = G 1/4	G = 1/4 NPT	bar	psi	d	b	h
CMM G 1/4-10	CMM 1/4 NPT-10	10	145	63	35.5	53
CMM G 1/4-16	CMM 1/4 NPT-16	16	230	63	35.5	53
CMM G 1/4-25	CMM 1/4 NPT-25	25	360	63	35.5	53
CMM G 1/4-40	CMM 1/4 NPT-40	40	580	63	35.5	53
CMM G 1/4-60	CMM 1/4 NPT-60	60	870	63	35.5	53
CMM G 1/4-100	CMM 1/4 NPT-100	100	1450	63	35.5	53
CMM G 1/4-160	CMM 1/4 NPT-160	160	2300	63	35.5	53
CMM G 1/4-250	CMM 1/4 NPT-250	250	3600	63	35.5	53
CMM G 1/4-400	CMM 1/4 NPT-400	400	5800	63	35.5	53
CMM G 1/4-600	CMM 1/4 NPT-600	600	8700	63	35.5	53

description		pressure range				
G = G 1/2	G = 1/2 NPT	bar	psi	d	b	h
CMM G 1/2-10	CMM 1/2 NPT-10	10	145	100	49	87
CMM G 1/2-16	CMM 1/2 NPT-16	16	230	100	49	87
CMM G 1/2-25	CMM 1/2 NPT-25	25	360	100	49	87
CMM G 1/2-40	CMM 1/2 NPT-40	40	580	100	49	87
CMM G 1/2-60	CMM 1/2 NPT-60	60	870	100	49	87
CMM G 1/2-100	CMM 1/2 NPT-100	100	1450	100	49	87
CMM G 1/2-160	CMM 1/2 NPT-160	160	2300	100	49	87
CMM G 1/2-250	CMM 1/2 NPT-250	250	3600	100	49	87
CMM G 1/2-400	CMM 1/2 NPT-400	400	5800	100	49	87
CMM G 1/2-600	CMM 1/2 NPT-600	600	8700	100	49	87

ADJUSTABLE GAUGE FITTING

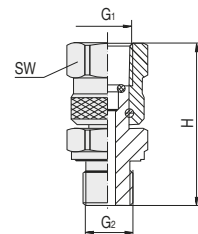

description	G1	G2	H	SW
VO-1/4	1/4	1/4	42.0	19
VO-1/4-1/2	1/4	1/2	47.0	19
VO-1/2-1/4	1/2	1/4	52.0	27
VO-1/2	1/2	1/2	55.5	27

CONTROL SYSTEM HOSE CONNECTOR

THE WORLD OF TUBE FITTINGS

HOSE ORDER DESCRIPTION

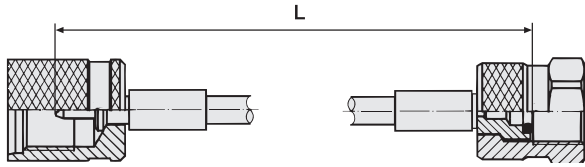

L

CS...MS¹⁾	1500	T	not specified DN
Connection 1	Length L	Connection 2	
H A J	hose length in mm	H A J	A = DN2 400 bar
S S D		S S D	B = DN2 630 bar
T K B		T K B	C = DN4 340 bar
12 L U		12 L U	
M G P		M G P	
N F		N F	
W C		W C	

1) Order code of hose for gaseous medium "CS...MSG"

for different connection on second side only

HOSE CONNECTOR

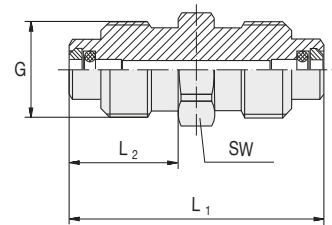

description	G	L1	SW
CSHMSAD	M16X2	42	17
CSSMSAD	M16x1.5	42	17
CS12MSAD	S12x1.5	44	19

CONTROL SYSTEM

HOSE FITTING

HOSE FITTING FOR CONTROL SYSTEM

HOSE FITTING TYPE HS

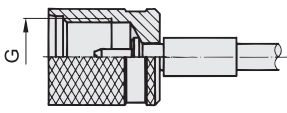
description	hose fitting	type	G	SW	DN
Rows of screws Connection for test couplings		H S	M16x2 M16x1.5		2 and 4

HOSE FITTING TYPE 12

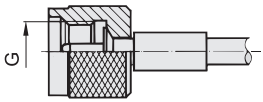
description	hose fitting	type	G	SW	DN
Rows of screws Connection for test couplings		12	S12.65x1.5		2 and 4

HOSE FITTING TYPE O

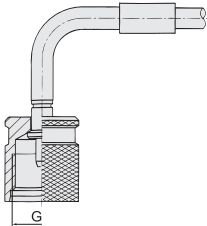
description	hose fitting	type	G	SW	DN
Rows of screws 90° bent Connection for test couplings		H S 12 O	M16x2 M16x1.5 S12.65x1.5		2

HOSE FITTING TYPE T CONNECT

description	hose fitting	type	G	SW	DN
Plugging line		T	connector system		2

CONTROL SYSTEM

HOSE FITTING

HOSE FITTING FOR CONTROL SYSTEM

THE WORLD OF TUBE FITTINGS

HOSE FITTING TYPE M

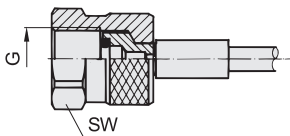
description	hose fitting	type	G	SW	DN	
Manometer connection Whitworth pipe thread G3/8 and G1/2 outer line See depiction type N		M	1/4	G1/4	19	2 and 4
			1/2	G1/2	27	
			3/8	G3/8	22	2

HOSE FITTING TYPE W

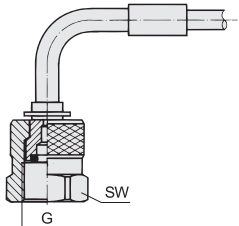
description	hose fitting	type	G	SW	DN	
Manometer connection Whitworth pipe thread 90° bent G3/8 and G1/2 outer line See depiction type N		W	1/4	G1/4	19	2
			1/2	G1/2	27	

HOSE FITTING TYPE N

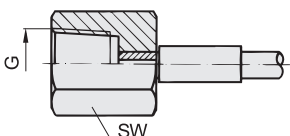
description	hose fitting	type	G	SW	DN	
Manometer connection With 1/4" NPT outer line See depiction type M		N	1/4	1/4 NPT	19	2
			1/2	1/2 NPT	27	

CONTROL SYSTEM

HOSE FITTING

HOSE FITTING FOR CONTROL SYSTEM

HOSE FITTING TYPE A

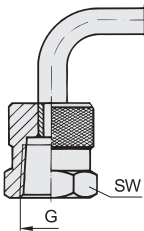
description	hose fitting	type	G	SW	DN	
Manometer connection NPT 90° bent With 1/4" NPT outer line See depiction type M		A	1/4	1/4 NPT	19	2 and 4
			1/2	1/2 NPT	27	

HOSE FITTING TYPE S

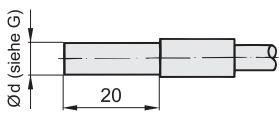
description	hose fitting	type	G	SW	DN	
Pipe socket for compression type fitting acc. to DIN 2353		S	4	4LL		2
			6	6L - 6S		2 and 4
			8	8L - 8S		2 and 4
			10	10L - 10S		2 and 4
			12	12L - 12S		2
			15	15L		2
			1/4	1/4"		2 and 4

HOSE FITTING TYPE S90°

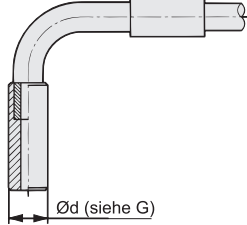
description	hose fitting	type	G	SW	DN	
Pipe socket for compression type fitting according to DIN 2353		S90° upon request				2 and 4

CONTROL SYSTEM

HOSE FITTING

HOSE FITTING FOR CONTROL SYSTEM

THE WORLD OF TUBE FITTINGS

HOSE FITTING TYPE K

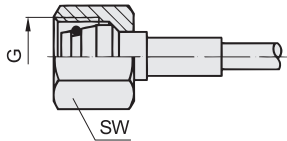
description	hose fitting	type	G	SW	DN	
Conical nipple with swivel nut and O-ring for 24° connectors		K	6LL	M10x1.0	12	4
			6L	M12x1.5	14	2 and 4
			8L	M14x1.5	17	2 and 4
			10L	M16x1.5	19	2 and 4
			12L	M18x1.5	22	2 and 4
			6S	M14x1.5	17	2 and 4
			8S	M16x1.5	19	2 and 4
			10S	M18x1.5	22	2 and 4
			12S	M20x1.5	24	2 and 4

HOSE FITTING TYPE R

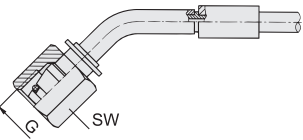
description	hose fitting	type	G	SW	DN	
Conical nipple with swivel nut and O-Ring for 24° connectors 45° bent		R	6S	M14x1.5	17	2 and 4

HOSE FITTING TYPE L

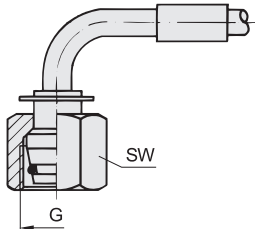
description	hose fitting	type	G	SW	DN	
Conical nipple with swivel nut and O-Ring for 24° connectors 90° bent		L	6L	M12x1.5	14	2 and 4
			8L	M14x1.5	17	
			10L	M16x1.5	19	
			6S	M14x1.5	17	
			8S	M16x1.5	19	
			10S	M18x1.5	24	

CONTROL SYSTEM
HOSE FITTING
HOSE FITTING FOR CONTROL SYSTEM

HOSE FITTING TYPE G

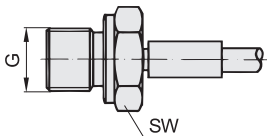
description	hose fitting	type	G	SW	DN	
External thread complying with DIN 3852-B		G	12	M12x1.5	17	2 and 4
			1/8	G 1/8	14	
			1/4	G 1/4	19	
			1/2	G 1/2	27	

HOSE FITTING TYPE F

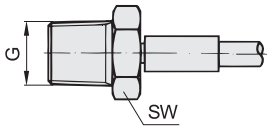
description	hose fitting	type	G	SW	DN	
External thread NPT acc. to ANSI		F	1/8	1/8 NPT	13	2 and 4
			1/4	1/4 NPT	17	

HOSE FITTING TYPE C

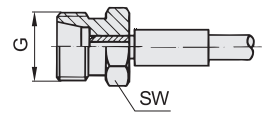
description	hose fitting	type	G	SW	DN	
External thread for 24° compression fitting acc. to DIN 3853		C	6L	M12x1.5	14	2 and 4
			8L	M14x1.5	17	
			6S	M14x1.5	17	
			8S	M16x1.5	17	

CONTROL SYSTEM

HOSE FITTING

HOSE FITTING FOR CONTROL SYSTEM

THE WORLD OF TUBE FITTINGS

HOSE FITTING TYPE J

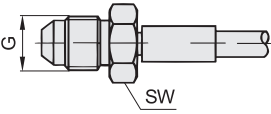
description	hose fitting	type		G	SW	DN
External thread acc. to SAE J514		J	1/4	7/16-UNF	14	2 and 4
			5/16	1/2-UNF	14	
			3/8	9/16-UNF	17	

HOSE FITTING TYPE D

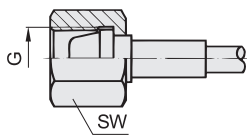
description	hose fitting	type		G	SW	DN
Conical pipe with swivel nut for 24° connector acc. to DIN 2353		D	6L	M12x1.5	14	2 and 4
			8L	M14x1.5	17	
			10L	M16x1.5	19	
			12L	M18x1.5	22	
			6S	M14x1.5	17	
			8S	M16x1.5	19	
			10S	M18x1.5	22	
			12S	M20x1.5	24	

HOSE FITTING TYPE Q

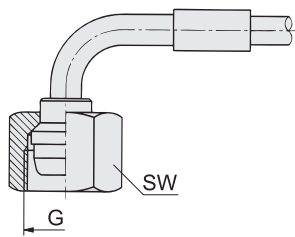
description	hose fitting	type		G	SW	DN
Conical pipe with swivel nut for 24° connector acc. to DIN 2353 standards 90° bent		Q	10L	M16x1.5	19	2 and 4
			10S	M18x1.5	22	

CONTROL SYSTEM
HOSE FITTING
HOSE FITTING FOR CONTROL SYSTEM

HOSE FITTING TYPE B

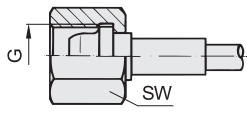
description	hose fitting	type	G	SW	DN		
Conical pipe with swivel nut acc. to DIN 8542		B	1/4	G 1/4	17	2 and 4	

HOSE FITTING TYPE U

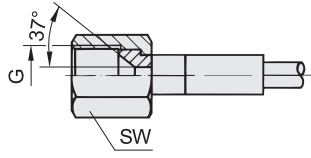
description	hose fitting	type	G	SW	DN	
Conical pipe with swivel nut complying with SAE J514 for 37° connector		U	1/4	7/16-20 UNF	14	2 and 4
			5/16	1/2-20 UNF	17	
			3/8	9/16-18 UNF	19	

HOSE FITTING TYPE UR

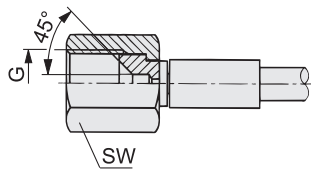
description	hose fitting	type	G	SW	DN		
Conical pipe with swivel nut complying with SAE J516 for 45° connectors		UR	1/4	7/16-20 UNF	14	2	

CONTROL SYSTEM

HOSE FITTING

HOSE FITTING FOR CONTROL SYSTEM

THE WORLD OF TUBE FITTINGS

HOSE FITTING TYPE E

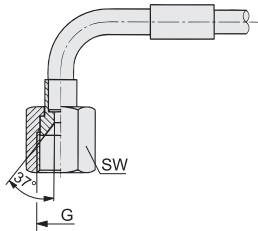
description	hose fitting	type	G	SW	DN	
Conical pipe with swivel nut acc. to SAE J514 for 37° connector 90° bent		E	1/4	7/16-20UNF	14	2

HOSE FITTING TYPE ER

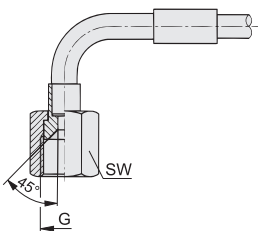
description	hose fitting	type	G	SW	DN	
Conical pipe with swivel nut acc. to SAE J514 for 45° connector 90° bent		ER	1/4	7/16-20UNF	14	2

HOSE FITTING TYPE P

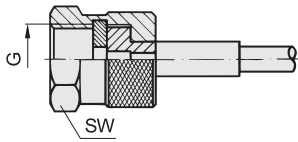
description	hose fitting	type	G	SW	DN	
Measuring hose for vehicle brake systems		P	2	M16x1.5	19	2

CONTROL SYSTEM
HOSE FITTING
HOSE FITTING FOR CONTROL SYSTEM

HOSE FITTING TYPE H

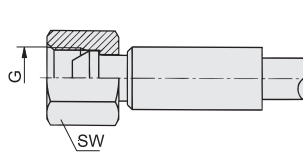
description	hose fitting	type	G	SW	DN
Conical pipe with swivel nut for 60° connector		H	1/4 G 1/4	17	4

HOSE FITTING TYPE T

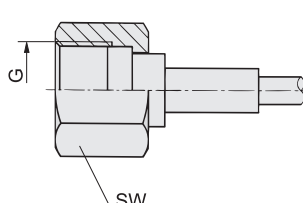
description	hose fitting	type	G	SW	DN
Screwed connection ORS acc. to SAE J1453		T	11/16 11/16-16 UN	21	2

HOSE FITTING TYPE V

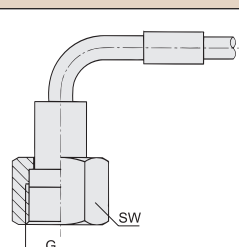
description	hose fitting	type	G	SW	DN
Screwed connection ORS acc. to SAE J 1453 90° bent		V	11/16 11/16-16UN	21	2 and 4



INTEGRATED FLUID POWER SOLUTIONS

THE WORLD OF ASSEMBLY MACHINERY



EMB-FS® CONNECTION TECHNOLOGY

THE WORLD OF ASSEMBLY MACHINERY



EASY, QUICK AND RELIABLE

The innovative 'Form & Seal' system was designed for the connection of tubes without specific tube preparation and finishing. It boasts the advantages of a welding system but the number of necessary single parts is reduced to the minimum, optimising the cost-performance ratio and minimising the system costs. The system can also be used for nearly all applications as we provide a comprehensive product portfolio of DIN 2353, ISO 8434-1 tube fittings. The EMB-FS® system and assembly procedure guarantees you minimum tube stress, fast assembly and maximum retention forces.

Improve productivity and keep costs down

The EMB-FS® 93 forming machine works so simply that it helps to reduce tool costs and operation time significantly. The convenient display helps to select tube sizes easily and promptly, making assembly errors impossible. The electronic power path control procedure forms standard hydraulic pipes continuously, ensuring safe tube forming. Different wall thicknesses can be processed with only one tool set, making the tool logistics easier and affordable. When a tool change is needed, this can also happen very quickly and effortlessly with the use of the bayonet catch.



The unmatched tube connecting solution for steel and stainless steel tubes



No compromises, no difficulties

A function ring supports the final assembly. It integrates an elastomer seal into the system and protects against excessive tightening. Frictional tension between tube and fitting cone is assured with the metallic seal function. Vulcanised soft seals ensure the leak-free performance in extreme working conditions as well. Safe assembly is indicated by a clearly noticeable assembly stop.

Form & Seal hydraulic pipes with complete confidence

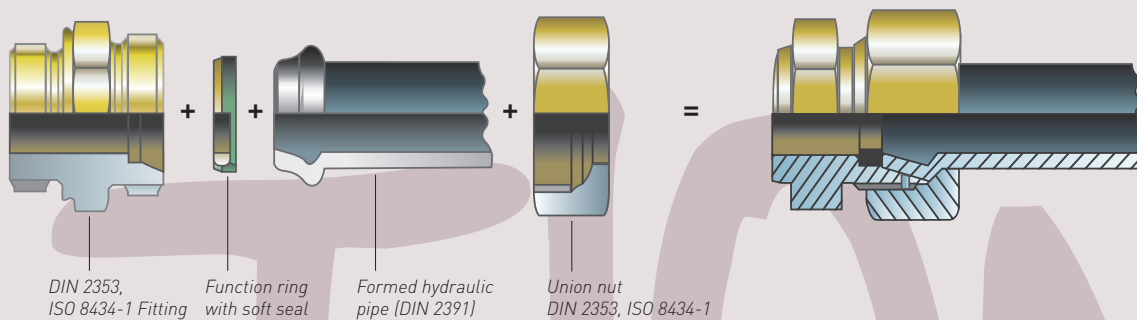

GATES ASSEMBLY MACHINERY – HIGH PRODUCTIVITY WHEREVER YOU NEED IT!

THE WORLD OF ASSEMBLY MACHINERY



Gates assembly machinery can help you to cut maintenance costs, boost productivity and outperform others thanks to our focus on design, innovation and top-quality materials. The range covers all your needs from workshops to mobile service operations and even on-site field crimping.

Leak-free and reliable high-performance port-to-port solutions call for superiority, both in its components as well as the self-assembly machines to put them together. Our machinery is a vital part of the Gates Integrated System Approach, making every tube connection and every hose assembly a true Gates ambassador.

Gates is the world's most trusted brand name in fluid power transmission because we pay meticulous attention to quality standards in all cutting ring assembly, flaring, tube end forming, tube manipulation, cutting, crimping and marking, and conduct extensive quality testing before shipment.



CUTTING RING ASSEMBLY & FLARING MACHINERY

Today, cutting ring and flaring are still the main technologies used to connect tubes. To guarantee leak-free results, the joint procedure requires reliable machines that support the quality of the connection. Thanks to the Gates assembly machines' accurate processes, a minimum of the operator's individual intervention is required, reducing the need for manual justifications as well as process control.

OVERVIEW



Opticam 34 Cutting Ring Assembly Machine

Hydraulic operating machine with SPC unit (storage programmable control) for both pre-assembly and final-assembly of cutting rings. The fully automated assembly procedure ensures total supervision and absolute control of the chosen kind of assembly, preventing mistakes and eliminating additional maintenance and complaints. It is the customer's warranty for 100% leak free connections.

Technical Specifications Opticam 34		CAM 34		CAM 34 power pack	
		400 V / 3-phase		400 V / 3-phase	
working pressure	max. bar	400		400	
assembly pressure	max. tons	20		20	
hydraulic unit	ltr./min	3		3 + 1.25	
electric drive	Hz	50		50	
dimensions (mm)	H	300		620	
	W	610		260	
	D	625		550	
weight	ca. kg	85		50 incl. oil	
cylinder movement	max. sec.	2,4	e.g. Ø 12 mm	1,9	e.g. Ø 12 mm
order code		CAM 34		CAM 34 DP	

Tools	CAM 34
Pre-assembling counter plate	OPT/E
Pre-assembling socket	OPTI
Final assembling counter plate	OPT/F
Final assembling socket	OPTI/F

CUTTING RING ASSEMBLY & FLARING MACHINERY

THE WORLD OF ASSEMBLY MACHINERY

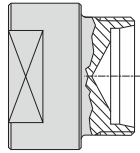

VM Pre-Assembly Bodies

Bodies for the turning-angle-controlled serial assembly of cutting ring fittings in the pre-assembly adaptor VM with subsequent final assembly.

Technical Specifications VM Pre-Assembly Bodies				
Description	tube OD	G	L	S
VM 6-L	6	M 12 x 1.5	28	14
VM 8-L	8	M 14 x 1.5	28	14
VM 10-L	10	M 16 x 1.5	28	14
VM 12-L	12	M 18 x 1.5	28	19
VM 15-L	15	M 22 x 1.5	33	19
VM 18-L	18	M 26 x 1.5	36	24
VM 22-L	22	M 30 x 2	37	27
VM 28-L	28	M 36 x 2	40	32
VM 35-L	35	M 45 x 2	42	41
VM 42-L	42	M 52 x 2	42	50
VM 6-S	6	M 14 x 1.5	28	14
VM 8-S	8	M 16 x 1.5	28	14
VM 10-S	10	M 18 x 1.5	28	14
VM 12-S	12	M 20 x 1.5	28	19
VM 14-S	14	M 22 x 1.5	33	19
VM 16-S	16	M 24 x 1.5	33	24
VM 20-S	20	M 30 x 2	37	27
VM 25-S	25	M 36 x 2	39	32
VM 30-S	30	M 42 x 2	42	41
VM 38-S	38	M 52 x 2	42	50

CUTTING RING ASSEMBLY & FLARING MACHINERY



UP/M Unipress Cutting Ring Assembly

Hand assembly machine allowing easy cutting-ring pre-assembly and flaring 37° systems. The light-weight, user-friendly design makes it perfect for on-site applications and repairs.

Utilises same tools as electro-hydraulic machines.

Tube flaring for 37° Gates-EMB ABO and SAE system.

Technical Specifications UP/M Unipress		UP/M
		manually
tube range cutting ring assembly	mm Ø	6 to 42
tube range flaring	mm Ø	6 to 22
maximum pressure	bar	230
	H	260
dimensions (mm)	W	190
	D	400
weight	ca. kg	15
order code		UNIPRESS M

Tools	UP/M
Pre-assembling counter plate	OPT/E
Pre-assembling socket	OPTI
Flaring device	BÖRDELVORSATZ UPM622
Flaring tools for ABO 37°	UNI-BBO
Flaring tools SAE system	UNI-BB

CUTTING RING ASSEMBLY & FLARING MACHINERY

THE WORLD OF ASSEMBLY MACHINERY



UP 3 Unipress Cutting Ring Assembly & Flaring Machine

Universal combination machine for cutting ring pre-assembly with manual or automatic pressure setting and tube flaring for steel and stainless steel tubes with an outer diameter from 6 to 42 mm.

Technical Specifications UP 3 Unipress		UP 3
		400 V / 3-phase
working pressure	max. bar	0 to 200
electric drive	Hz	50
dimensions (mm)	H	500
	W	450
	D	650
weight	ca. kg	85
order code		UNIPRESS 3
Tools		UP 3
Pre-assembling counter plate		OPT/E
Pre-assembling socket		OPTI
Flaring tools for ABO 37°		UNI-BB0
Flaring tools SAE system		UNI-BB
Flaring tools SAE system		UNI-BB

TUBE END FORMING & TUBE MANIPULATION MACHINERY

Tube forming is not only one of the safest methods for the connection of leak-free hydraulic tube systems but can be used as an alternative for expensive welding procedures in many cases. The result is a huge cost reduction on both labour and system assembly cost. This supports economies of scale and provides extra time and money for further projects. Operator faults are basically excluded due to automated machine functions. Gates-EMB assembly machines are developed with individual customer needs in mind like ease of use, reliability and cost performance.

OVERVIEW



FS 93 Tube Forming Machine

The FS 93 forming machine offers fast and safe tube forming of both steel and stainless steel tubes. The forming happens in one single step with the help of the electronic power path control, reducing tool costs and operation time significantly.

Easy tube size selection via the machine display.

One tool set for different materials and tube wall thicknesses.

The bayonet catch allows very quick change of tools.

Technical Specifications FS 93		FS 93
		400 V / 3-phase
electric drive	Hz	50
fuse	A	16
dimensions (mm)	H	350
	W	760
	D	830
weight	ca. kg	175
order code		FS 93 UMFORMMASCHINE

Tools	FS 93	
Clamping jaws	SPW	
Reshaping tools	FOW	
Function ring	FSR	Ø 6 to 42 mm
Back-up ring	FSSR	Ø 6 to 12 mm

TUBE END FORMING & TUBE MANIPULATION MACHINERY

THE WORLD OF ASSEMBLY MACHINERY

Final Assembly with Function & Back-Up Ring

The FSR function ring and FSR back-up ring FSSR support the final assembly, integrating an elastomer seal into the system which protects against excessive tightening. The frictional tension between tube and fitting cone is assured with the metallic seal function. The vulcanised soft seals ensure the leak-free performance in extreme working conditions. Safe assembly is guaranteed by a clearly noticeable assembly stop. It is recommended to use FSR on tube diameters from 6 to 42 mm, FSSR alternatively from 6 to 12 mm with very thin wall thicknesses.



Function ring FSR	
Description steel	Description stainless steel
FSR 6-L/S	FSR 6 L/S-1.4571
FSR 8-L/S	FSR 8 L/S-1.4571
FSR 10-L/S	FSR 10 L/S-1.4571
FSR 12-L/S	FSR 12 L/S-1.4571
FSR 15	FSR 15 L/S-1.4571
FSR 16	FSR 16 L/S-1.4571
FSR 18	FSR 18 L/S-1.4571
FSR 20	FSR 20 L/S-1.4571
FSR 22	FSR 22 L/S-1.4571
FSR 25	FSR 25 L/S-1.4571
FSR 28	FSR 28 L/S-1.4571
FSR 30	FSR 30 L/S-1.4571
FSR 35	FSR 35 L/S-1.4571
FSR 38	FSR 38 L/S-1.4571
FSR 42	FSR 42 L/S-1.4571



Back-up ring FSSR	
Description steel	Description stainless steel
FSSR 6 L/S	FSSR 6 L/S-1.4571
FSSR 8 L/S	FSSR 8 L/S-1.4571
FSSR 10 L/S	FSSR 10 L/S-1.4571
FSSR 12 L/S	FSSR 12 L/S-1.4571



Tools SPW		
Description	tube OD mm	wall thickness mm
SPW 6L/S	6	1-1.5
SPW 8L/S	8	1-2.5
SPW 10L/S	10	1-3.0
SPW 12L/S	12	1-3.5
SPW 15L/S	15	2-3.0
SPW 16L/S	16	2-4.0
SPW 18L/S	18	2-3.0
SPW 20L/S	20	2.5-4.0
SPW 22L/S	22	2-3.5
SPW 25L/S	25	2.5-5.0
SPW 28L/S	28	2.5-5.0
SPW 30L/S	30	3-6.0
SPW 35L/S	35	2.5-6.0
SPW 38L/S	38	3-6.0
SPW 42L/S	42	3-4.0

Tools FOW		
Description	tube OD mm	wall thickness mm
FOW 6X1-1,5 L/S	6	1-1.5
FOW 8X1-1,5 L/S	8	1-1.5
FOW 8X2+L/S	8	2-2.5
FOW 10X1-1,5L/S	10	1-1.5
FOW 10X2+L/S	10	2-3.0
FOW 12X1-1,5L/S	12	1-1.5
FOW 12X2+L/S	12	2-3.5
FOW 15X2+	15	2-3.0
FOW 16X2+	16	2-4.0
FOW 18X2+	18	2-3.0
FOW 20X2,5+	20	2.5-4.0
FOW 22X2+	22	2-3.5
FOW 25X2,5+	25	2.5-5.0
FOW 28X2,5+	28	2.5-5.0
FOW 30X3+	30	3-6.0
FOW 35X2,5+	35	2.5-6.0
FOW 38X3+	38	3-6.0
FOW 42X3+	42	3-4.0

TUBE END FORMING & TUBE MANIPULATION MACHINERY



Mobilpress PB 642 Tube Bending Machine

Machine for hydraulic bending of tubes of 6-42 mm in steel St35, St37, St52 as well as stainless steel tubes. The maximum bending efficiency is 38x5 mm resp. 42x4 mm.

Three different machines are available.

- > PBEH 642 F
- > PBEH 642
- > PBM 642

Technical Specifications PB 642 Mobilpress		PBEH 642 F	PBEH 642	PBM 642
		400 V / 3-phase	400 V / 3-phase	manual
operating pressure	max. bar	250	250	
electric drive	Hz	50	50	
weight	ca. kg	70		
tube bending efficiency	mm diameter x wall thickness	38x5 or 42x4	38x5 or 42x4	
order code		PRESSBIEGER PBEH 642 - F	PRESSBIEGER PBEH 642	PRESSBIEGER PBM

Tools	PB 642
Bending matrix	TPM
Bending wing head	TPG



Bending Tools TPM



Bending Wing Heads TPG

Tools TPM			
Description	tube OD mm; inch	thread tube OD mm	bending radius
TPM 06	6		2.0xD
TPM 08	8		2.0xD
TPM 10	10		2.0xD
TPM 12	12		2.0xD
TPM 14	14; 1/4	13.5	2.0xD
TPM 15	15		2.0xD
TPM 16	16		2.0xD
TPM 18	18; 3/8	17.2	2.5xD
TPM 20	20		2.0xD
TPM 22	22; 1/2	21.3	2.5xD
TPM 25	25		2.4xD
TPM 28	28; 3/4	26.9	2.7xD
TPM 30	30		2.5xD
TPM 35	35; 1	33.7	3.0xD
TPM 38	38		2.5xD
TPM 42	42; 1 1/4	42.1	3.0xD

Tools TPG	
Description	tube OD mm
TPG 6/8	6 + 8
TPG 10/12	10 + 12
TPG 14/16	14 + 16
TPG 18/20	18 + 20
TPG 22/25	22 + 25
TPG 28/30	28 + 30
TPG 35/38	35 + 38
TPG 42	42

TUBE END FORMING & TUBE MANIPULATION MACHINERY

THE WORLD OF ASSEMBLY MACHINERY



RBV 6/18 Tube Bending Device

This device comes with 6 changeable bending rollers for tubes from 6 to 18 mm.

Weight of each piece: approx. 4 kg

Ease-of-use: ideal for workshop independent, mobile bending operations.

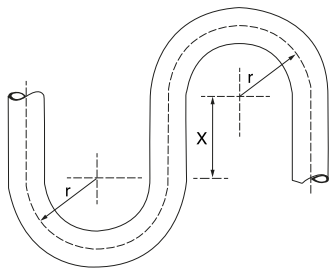

Technical Specifications RBV 6/18

Description	tube OD mm	gas tube	r	~ x	~ kg/pc
RBV 6/18	6		33.0	35	4
	8		34.0	35	
	10	1/8	35.5	35	
	12		36.5	35	
	14	1/4	36.5	35	
	15		44.0	38	
	16		44.0	38	
	18	3/8	51.5	42	

CUTTING MACHINES

Gates cutters – both the hose cutters and steel tube cutters – are robust and compact machines, and distinguish themselves by their safe and high-quality cutting function. Our range of electrical cutters is all hand controlled for guided cutting thus allowing for optimal speed control and a reduction of blade damage. The blades are positioned close to the powerful motors to limit vibration which enhances the durability and reduces maintenance costs. But there is more: low energy consumption, CE compliant brake motors for 3-phase cutting machines, built-in protection, limited smoke production ... all supporting your safe working environment and personnel safety.

OVERVIEW







Unicut TC 080 Metal Saw

Unicut is a compact transportable hand circular saw for all types of metal tubes. The saw can be used for straight and mitre cuts, has an integrated automatic cooler and offers best performance for accurate cuts in order to fit tubes perfectly.

Saw blades high-speed steel with DMO surface coating.

Dimension 250 x 2.0 x 32 with 2 side holes 12/64 mm.

cutting section		45°	90°
	mm Ø	70	80
	mm Ø	40	40
	mm	60	70
	mm	40	40
	mm	65x60	95x60

Technical Specifications Unicut TC 080		TC 080	TC 080
		400 V / 3-phase	220 V
mitre cuts		up to 45°	up to 45°
electric drive	kW/Hz	1.0/50	0.8/50
weight	ca. kg	71	71
rotational speed	rev/min	52	52
dimensions (mm)	H	700	700
	W	850	850
	D	450	450
order code		UNICUT TC 080/380V	UNICUT TC 080/220V

Tools	TC 080
Saw blade for thick-walled profiles and solid materials	HSS-SÄGEBLATT 250/128
Saw blade for thin-walled profiles and tubes	HSS-SÄGEBLATT 250/200

CUTTING MACHINES

THE WORLD OF ASSEMBLY MACHINERY



MKX 40 Hose Cutter

Heavy-duty hose cutter allowing quick and reliable production across all hose size ranges. Cuts up to 2" six spiral wire hose. The brake motor ensures the blade stops turning within 10 seconds after switch-off. For workshop professionals who want to further enhance their set-up and improve ease-of-use.

Ref: 7480-19229: 3 phase

Technical Specifications MKX 40		
		3 phase
power supply		380V
maximum capacity	WB	2"
	4SW	2"
	6SW	2"
motor (kW)		4.6
brake motor		x
noise level		90dB
suction connection (mm)		60
cutting blade		350x3x30
dimensions (mm)	H	430
	W	690
	L	745
weight (kg)		75
product number		7480-19229

CUTTING MACHINES



MKX 30 Hose Cutter

Robust cutter for all types of workshops. Cuts up to 1.1/4" six spiral wire hose. The brake motor ensures the blade stops turning within 10 seconds after switch-off.

Ref: 7480-19191: 3 phase

Technical Specifications MKX 30		
		3 phase
power supply		380V
maximum capacity	WB	1.1/4"
	4SW	1.1/4"
	6SW	1.1/4"
motor (kW)		3.0
brake motor		x
noise level		80dB
suction connection (mm)		80
cutting blade		275x3x30
dimensions (mm)	H	300
	W	440
	L	540
weight (kg)		50
product number		7480-19191

CUTTING MACHINES

THE WORLD OF ASSEMBLY MACHINERY



MKX 25 Hose Cutter

Compact cutting machine, perfectly suitable for the small workshop. Cuts up to 1.1/4" four spiral wire hose.

Ref: 7480-19190: 1 phase / 7480-19189: 12V

Technical Specifications MKX 25			
		DC	1 phase
power supply		12V	220V
maximum capacity	WB	1.1/4"	1.1/4"
	4SW	1.1/4"	1.1/4"
	6SW	--	--
motor (kW)		2.0	2.2
brake motor		--	--
noise level		93dB	90dB
suction connection (mm)		40	40
cutting blade		250x2.5x40	200x1.6x30
dimensions (mm)	H	365	540
	W	567	510
	L	470	400
weight (kg)		29	20
product number		7480-19189	7480-19190

ACCESSORIES



MKX Suction Unit

MKX Suction Unit allowing you to safely remove rubber particles and smoke released during the hose cutting operation. The particles are sucked into the container removing any hindering smell. The spark arrester between the cleaner box and the suction hose also ensures that glowing particles and rubber waste are immediately removed, thus minimizing the risk for fire.

Depending which MKX-cutter you have selected you can select the right adaptor to connect your cutter to the MKX suction unit:

- > MKX40 adaptor ring: 80 mm Ø connection (8000-10395)
- > MKX30 adaptor ring: 50 mm Ø connection (8000-10368)
- > MKX25 adaptor ring: 40 mm Ø connection (8000-10375)

Ref: 8000-10367

CRIMPING MACHINES

With Gates crimpers safe, fast and efficient assembly of hydraulic hoses and couplings is made simple. All machines are custom-designed to work with a well-defined range of Gates hoses and couplings allowing production of factory-quality assemblies fully complying with European Directives and the most stringent international standards. In addition, our self-assembly machinery offers the highest care and personal safety in your working environment (from workshops to mobile service operations and even on-site field crimping).

Lower maintenance costs from grease-free machines

Gates MCX crimpers cut your maintenance costs by running grease-free. These crimpers come with a unique, self-lubricating slide bearing system that cuts out metal-to-metal abrasion between master dies and the crimper head and cuts friction by 20%. No need for greasing also brings you a safer and cleaner working environment.

Easy-to-use products improve productivity

All Gates applications are designed to ensure fast, comfortable handling and we have incorporated this also in our crimper program. In our electrical-driven crimpers, a standard built-in storage rack lets you choose dies quickly, and die sets are easy-to-reach and organised logically. Field service crimping devices are portable and come with a detachable die storage case, solid and durable handles and resistant rubber protection layers. Our ergonomic design is highly valued both for its contribution to higher productivity figures and its fast approval by local Health and Safety Executives.

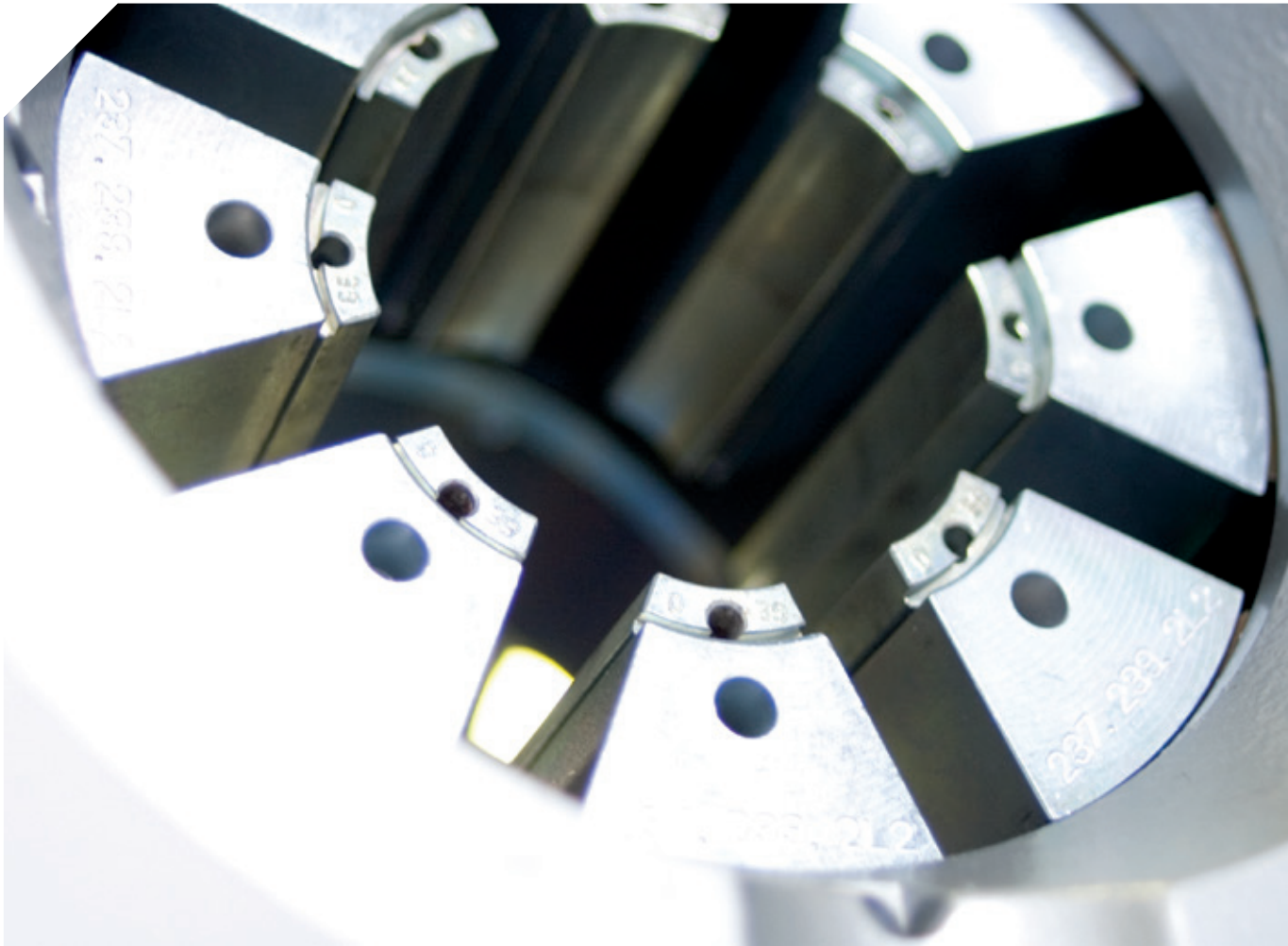

CRIMPING MACHINES

THE WORLD OF ASSEMBLY MACHINERY

OVERVIEW



MCX 50

Full-range crimper (up to 2" six spiral wire hose) for the professional workshop. Optional foot pedal to enable hands-free operation. Equipped with a die set storage rack allowing for logically organised die storage within easy reach of the operator, thus speeding up die selection and assembly.

Ref: 7480-19188: 3 phase

Technical Specifications MCX 50		
		3 phase
power supply		380V
maximum capacity	WB	2"
	4SW	2"
	6SW	2"
crimping force (ton)		280
motor (kW)		5.5
die set		239*/237-Dxx
cycle time (sec)		18
die storage		rack
dimensions (mm)	H	1400
	W	580
	L	610
weight (kg)		410
product number		7480-19188
options	marking dies	x**
	quick die change	x
	back stop	7480-19198
	foot pedal	7480-19199

* Only with intermediate dies.

** Marking die in type 239 only up to 239-D37.

CRIMPING MACHINES



MCX 30

Compact, operator-friendly machine to crimp the complete Gates range up to 1.1/4". Equipped with a die set storage rack allowing for logically organised die storage within easy reach of the operator, thus speeding up die selection and assembly. Also available for mobile service with separate DC power pack.

Ref: 7480-19187: 3 phase / 7480-19186: 1 phase / 7480-19186: 12V

Technical Specifications MCX 30				
		DC	1 phase	3 phase
power supply		12V	220V	380V
maximum capacity	WB	1.1/4"	1.1/4"	1.1/4"
	4SW	1.1/4"	1.1/4"	1.1/4"
	6SW	1.1/4"	1.1/4"	1.1/4"
crimping force (ton)		180	180	180
motor (kW)		1.8	2.2	3
die set		239-Dxx	239-Dxx	239-Dxx
cycle time (sec)		41	41	20
die storage		rack	rack	rack
dimensions (mm)	H	550	790	790
	W	475	600	600
	L	395	550	550
weight (kg)		125	170	170
product number		7480-19185	7480-19186	7480-19187
options	marking dies	x*	x*	x*
	quick die change	x	x	x

* Marking die in type 239 only up to 239-D37.

CRIMPING MACHINES

THE WORLD OF ASSEMBLY MACHINERY



MCX 25

Compact crimper for low-volume production. Ideal as starter machine or for small workshops. Crimps no-skive GlobalSpiral couplings up to 1" and no-skive MegaCrimp® couplings for wire-braid hose up to 1.1/4". Equipped with a die set storage rack allowing for logically organised die storage within easy reach of the operator, thus speeding up die selection and assembly. Also available for mobile service with separate DC power pack.

Ref: 7480-19184: 3 phase / 7480-19183: 1 phase / 7480-19182: 12V

Technical Specifications MCX 25				
		DC	1 phase	3 phase
power supply		12V	220V	380V
maximum capacity	WB	1.1/4"	1.1/4"	1.1/4"
	4SW	1"	1"	1"
	6SW	--	--	--
crimping force (ton)		130	130	130
motor (kW)		1.8	2.2	3
die set		239-Dxx	239-Dxx	239-Dxx
cycle time (sec)		39	39	19
die storage		rack	rack	rack
dimensions (mm)	H	550	790	790
	W	475	600	600
	L	395	550	550
weight (kg)		115	160	160
product number		7480-19182	7480-19183	7480-19184
options	marking dies	x*	x*	x*
	quick die change	x	x	x

* Marking die in type 239 only up to 239-D37.

CRIMPING MACHINES



MCX 20

Powerful, lightweight, portable hand-operated crimper, ideal for field service operations. Comes with separate box, designed to contain complete set of dies. Crimps no-skive GlobalSpiral couplings up to 1" and no-skive MegaCrimp® couplings for wire-braid hose up to 1.1/4".

Ref: 7480-19181

Technical Specifications MCX 20		
		manual
power supply		--
maximum capacity	WB	1.1/4"
	4SW	1"
	6SW	--
crimping force (ton)		90
die set		263-Dxx
die storage		box
dimensions (mm)	H	370
	W	450
	L	470
weight (kg)		35
product number		7480-19181
options	marking dies	x*

* Marking die in type 263 only up to 263-D35.



MC 1001

Lightweight, portable crimper designed for reliability in field service. Comes with separate box, designed to contain complete set of dies. The pneumatic version has a foot-operated air pump. Crimps no-skive MegaCrimp® couplings for wire-braid hose up to 1".

Ref: 7480-19164: manual machine / 7480-19165: air operated machine

Technical Specifications MC 1001			
		manual	pneumatic
power supply		--	7bar/100psi
maximum capacity	WB	1"	1"
	4SW	--	--
	6SW	--	--
crimping force (ton)		27	27
die set		MC1000-Dxx	MC1000-Dxx
die storage		box	box
dimensions (mm)	H	460	460
	W	280	280
	L	390	390
weight (kg)		24	22
product number		7480-19164	7480-19165

CRIMPING MACHINES

THE WORLD OF ASSEMBLY MACHINERY

DIE SELECTION MATRIX

Current Machinery

-size	Hose					Coupling	Die	MC1001 MC1000-Dxx	MCX20 MCX 263-Dxx	MCX25 MCX 239-Dxx	MCX30 MCX 239-Dxx
-4	M6K	M5K	M4K	M3K		G	D21	x	x	x	x
	CM2T	G2	G1	TH8	TH7	G	D21	x	x	x	x
	G3H	GTH		ACR		G	D21	x	x	x	x
	2JC	1JC	GP80+	GP60	GP40	G	D21	x	x	x	x
-5		M5K	M4K	M3K		G	D22	x	x	x	x
	CM2T	G2	G1		TH7	G	D22	x	x	x	x
		GTH				G	D22	x	x	x	x
	2JC	1JC	GP80+	GP60	GP40	G	D22	x	x	x	x
-6		M5K	M4K	M3K		G	D22	x	x	x	x
	CM2T	G2	G1	TH8	TH7	G	D22	x	x	x	x
	G3H	GTH		ACR		G	D22	x	x	x	x
	2JC	1JC	GP80+	GP60	GP40	G	D22	x	x	x	x
	EFG6K	EFG5K	EFG4K			GS	D33		x	x	x
-8		M5K	M4K	M3K		G	D33	x	x	x	x
	CM2T	G2	G1	TH8	TH7	G	D33	x	x	x	x
	G3H	GTH		ACR		G	D33	x	x	x	x
	2JC	1JC	GP80+	GP60	GP40	G	D33	x	x	x	x
	EFG6K	EFG5K	EFG4K			GS	D33		x	x	x
-10			M4K	M3K		G	D34	x	x	x	x
	CM2T	G2	G1			G	D34	x	x	x	x
	G3H	GTH		ACR		G	D34	x	x	x	x
			GP80+	GP60	GP40	G	D34	x	x	x	x
	EFG6K	EFG5K	EFG4K		HD-UHP	GS	D35		x	x	x
-12			M4K	M3K		G	D35	x	x	x	x
	CM2T	G2	G1	TH8	TH7	G	D35	x	x	x	x
		GTH	GMV	ACR		G	D35	x	x	x	x
			GP80+	GP60	GP40	G	D35	x	x	x	x
	EFG6K	EFG5K	EFG4K		HD-UHP	GS	D35		x	x	x
-16				M3K		G	D37	x	x	x	x
	CM2T	G2	G1	TH8	TH7	G	D37	x	x	x	x
		GTH	GMV	ACR		G	D37	x	x	x	x
			GP80+	GP60	GP40	G	D37	x	x	x	x
	EFG6K	EFG5K	EFG4K		HD-UHP	GS	D37		x	x	x
-20		G2	G1			G	D39		x	x	x
			GMV	ACR		G	D39		x	x	x
			GP80+		GP40	G	D39		x	x	x
			EFG4K	EFG3K			GS	D39			x
	EFG6K	EFG5K			HD-UHP	GS	D310				x
-24	M2T	G2	G1			GSP	D310				
			GMV	ACR		GSP	D310				
			GP80+		GP40	GSP	D310				
				EFG3K			GSP	D311			
	EFG6K	EFG5K				GSM	D311				
-32	M2T	G2	G1			GSP	D312				
			GMV	ACR		GSP	D312				
			GP80+			GSP	D312				
				EFG3K				D313			
	EFG6K	EFG5K					D314				

wire-braid reinforcement

4 spiral wire reinforcement

6 spiral wire reinforcement

* Only with intermediate dies

Note: High/Low Temp, MTF, XTF & Twin solutions follow the die set recommendation of its standard equivalent

CRIMPING MACHINES

Legacy Machinery

	MCX50 MCX 239-Dxx *	MCX50 237-Dxx	MC5001 - MC3001 - MC2501	MC5000 - MC3000 - MC2000	K2503 - MC1000	K4003 - K7003 - S5101	P32 - FP110 - P51 - FP120 - FP140 - FP160	P20HP - FP20 - P21
	x		MC5001-D21	MC5001-D21	MC1001-D21	K4/K7/S5-D21	FP P32-D21	FP P20-D21
	x		MC5001-D21	MC5001-D21	MC1001-D21	K4/K7/S5-D21	FP P32-D21	FP P20-D21
	x		MC5001-D21	MC5001-D21	MC1001-D21	K4/K7/S5-D21	FP P32-D21	FP P20-D21
	x		MC5001-D21	MC5001-D21	MC1001-D21	K4/K7/S5-D21	FP P32-D21	FP P20-D21
	x		MC5001-D22	MC5001-D22	MC1001-D22	K4/K7/S5-D22	FP P32-D22	FP P20-D22
	x		MC5001-D22	MC5001-D22	MC1001-D22	K4/K7/S5-D22	FP P32-D22	FP P20-D22
	x		MC5001-D22	MC5001-D22	MC1001-D22	K4/K7/S5-D22	FP P32-D22	FP P20-D22
	x		MC5001-D22	MC5001-D22	MC1001-D22	K4/K7/S5-D22	FP P32-D22	FP P20-D22
	x		MC5001-D22	MC5001-D22	MC1001-D22	K4/K7/S5-D22	FP P32-D22	FP P20-D22
	x		MC5001-D22	MC5001-D22	MC1001-D22	K4/K7/S5-D22	FP P32-D22	FP P20-D22
	x		MC5001-D22	MC5001-D22	MC1001-D22	K4/K7/S5-D22	FP P32-D22	FP P20-D22
	x		MC5001-D22	MC5001-D22	MC1001-D22	K4/K7/S5-D22	FP P32-D22	FP P20-D22
	x		MC5001-D33	MC5001-D33		K4/K7/S5-D33	FP P32-D33	FP P20-D33
	x		MC5001-D33	MC5001-D33	MC1001-D33	K4/K7/S5-D33	FP P32-D33	FP P20-D33
	x		MC5001-D33	MC5001-D33	MC1001-D33	K4/K7/S5-D33	FP P32-D33	FP P20-D33
	x		MC5001-D33	MC5001-D33	MC1001-D33	K4/K7/S5-D33	FP P32-D33	FP P20-D33
	x		MC5001-D33	MC5001-D33	MC1001-D33	K4/K7/S5-D33	FP P32-D33	FP P20-D33
	x		MC5001-D33	MC5001-D33		K4/K7/S5-D33	FP P32-D33	FP P20-D33
	x		MC5001-D34	MC5001-D34	MC1001-D34	K4/K7/S5-D34	FP P32-D34	FP P20-D34
	x		MC5001-D34	MC5001-D34	MC1001-D34	K4/K7/S5-D34	FP P32-D34	FP P20-D34
	x		MC5001-D34	MC5001-D34	MC1001-D34	K4/K7/S5-D34	FP P32-D34	FP P20-D34
	x		MC5001-D34	MC5001-D34	MC1001-D34	K4/K7/S5-D34	FP P32-D34	FP P20-D34
	x		MC5001-D35	MC5001-D35			FP P32-D35	FP P20-D35
	x		MC5001-D35	MC5001-D35	MC1001-D35	K4/K7/S5-D35	FP P32-D35	FP P20-D35
	x		MC5001-D35	MC5001-D35	MC1001-D35	K4/K7/S5-D35	FP P32-D35	FP P20-D35
	x		MC5001-D35	MC5001-D35	MC1001-D35	K4/K7/S5-D35	FP P32-D35	FP P20-D35
	x		MC5001-D35	MC5001-D35	MC1001-D35	K4/K7/S5-D35	FP P32-D35	FP P20-D35
	x		MC5001-D35	MC5001-D35	MC1001-D35	K4/K7/S5-D35	FP P32-D35	FP P20-D35
	x		MC5001-D35	MC5001-D35			FP P32-D35	FP P20-D35
	x		MC5001-D37	MC5001-D37	MC1001-D37	K4/K7/S5-D37	FP P32-D37	FP P20-D37
	x		MC5001-D37	MC5001-D37	MC1001-D37	K4/K7/S5-D37	FP P32-D37	FP P20-D37
	x		MC5001-D37	MC5001-D37	MC1001-D37	K4/K7/S5-D37	FP P32-D37	FP P20-D37
	x		MC5001-D37	MC5001-D37	MC1001-D37	K4/K7/S5-D37	FP P32-D37	FP P20-D37
	x		MC5001-D37	MC5001-D37			FP P32-D37	FP P20-D37
	x		MC5001-D39	MC5001-D39			FP P32-D39	FP P20-D39
	x		MC5001-D39	MC5001-D39			FP P32-D39	FP P20-D39
	x		MC5001-D39	MC5001-D39			FP P32-D39	FP P20-D39
	x		MC5001-D39	MC5001-D39			FP P32-D39	FP P20-D39
	x		MC5001-D310B	MC5001-D310B			FP P32-D310	
	x		MC5001-D310B	MC5001-D310B			FP P32-D310	
	x		MC5001-D310B	MC5001-D310B			FP P32-D310	
	x		MC5001-D310B	MC5001-D310B			FP P32-D310	
		x	MC5001-D311	MC5001-D311			FP P32-D311	
		x	MC5001-D311	MC5001-D311			FP P32-D311	
		x	MC5001-D312	MC5001-D312			FP P32-D312	
		x	MC5001-D312	MC5001-D312			FP P32-D312	
		x	MC5001-D312	MC5001-D312			FP P32-D312	
		x	MC5001-D313	MC5001-D313			FP P32-D313	
		x	MC5001-D314B	MC5001-D314B			FP P32-D314	

Note: The list of die sets for legacy machines does not indicate the capability of each given machine to the respective hose-coupling combination, but only gives an overview of the die sets available in the respective die type, please refer to your installation and calibration manual for maximum hose-coupling capability of your respective self-assembly machine.

CRIMPING MACHINES

THE WORLD OF ASSEMBLY MACHINERY

ACCESSORIES



Quick die change tool (QDC)

The universal quick die change tool allows fast and easy change of dies without risk of damage to the die sets. The transparent shield of the QDC allows you to quickly and safely position die sets into the master dies of the crimper head. A single press of the closing button is enough to lock the dies safely in place and rapidly produce a perfect hose assembly. When buying an electrical crimper, the QDC that goes together with the respective machine will be included in the package.

Ref: 7480-19194: QDC MCX 25 / 7480-19200: QDC MCX 30 / 7480-19195: QDC MCX 50



Marking dies

To facilitate compliance with the European Machinery Directive, which insists that finished assemblies are marked with the manufacturer's name and the manufacturing date code, a range of marking dies is now available for the MCX 50, MCX 30, MCX 25 and MCX 20 machines.

Please contact Gates for further information.



e-Crimp: online crimp settings in seconds

You no longer need to search through a stockpile of cd-roms to find the correct crimp settings. Go to ww2.gates.com/europe/e-crimp and use our fast sign-up procedure to obtain correct crimp settings in seconds! After logging in, you can access the Crimp Data Sheets, sorted by machine type. Select your machine type and print out an up-to-date sheet with accurate crimp data information or download the pdf documents to your desktop or mobile devices. Regular e-mails from our engineers keep you up to date about the newest crimp settings in the market.

ANCILLARIES



Optigrat OG 642 Tube Deburring Machine

Electrically driven deburring unit for quick and clean inner and outer deburring of tubes from 6 to 42 mm diameter. The device is made of HSS steel to ensure mark-free deburring with extraordinary service life.

Technical Specifications OG 642 Optigrat		OG 642
		400 V / 3-phase
rotational speed inner deburring	rev/min	300
rotational speed outer deburring	rev/min	200
electric drive	Hz	50
weight	ca. kg	30
dimensions (mm)	H	225
	W	492
	D	333
order code		OPTIGRAT OG 642



TC 1036 S Uniclean Tube Rinsing Machine

Tube systems should not be installed without being carefully cleaned to avoid blocked valves and other problems. Uniclean permits easy cleaning directly at the place of assembly and is applicable for tubes from 6-42 mm outer diameter. It is equipped with a two-stage turbo-nozzle and an effective tank sealing with a special air filter for easy maintenance.

Technical Specifications TC 1036 S Uniclean		TC 1036 S
TC 1036 S Uniclean	bar	6
maximum mains air pressure	bar	18
operating pressure	bar	2-8
max. working pressure medium to pistol	bar	32
max. air requirement	ltr./min	400
inner tube diameter	mm	4-40
max. tube length	m	6
max. hose length	m	7.5
medium tank capacity	ltr.	30
electric drive	Hz	50
weight	ca. kg	30
	mm H	500
	mm W	380
dimensions	mm D	640
order code		UNICLEAN TC 1036 S

ANCILLARIES

THE WORLD OF ASSEMBLY MACHINERY



Ref: 7480-19193

MSX Hose Assembly Marking machine

This hand-operated marking machine is a precise, compact service-free bench unit for Gates ferrules, one-piece and two-piece fittings. The MSX 50 is equipped with a hand wheel to adjust the character setting to the ferrule for the requested marking depth. The slot in the character holder allows for easy character placement. The machine is compliant with the European Machinery Directive. Please contact Gates for order info on the required characters.



Ref: 7480-00100

Push-on tool

Pushing couplings on hoses can be a tough job. Gates Push-on tool makes the insertion of couplings on hoses quick and easy. This hand-operated coupling machine, with its rugged cast iron and steel construction, eliminates the hard work of manually pushing stems into hoses and improves your hose assembly cost-efficiency.



Ref: 7482-1342

MegaCrimp® insertion tool

The MegaCrimp® coupling insertion tool offers an easy way to confirm the right insertion depth for all Gates wire-braid hydraulic hoses. It also verifies the squareness of cut!

ANCILLARIES



Hose perforator

Gates hose perforators have needle-studded wooden rollers which perforate the covers on no-skive wire-braid and spiral wire hoses used in pressure gas applications (up to 3.5 MPa). 7482-06565 is recommended for hoses from 3/16" to 3/4", 7482-06566 for hoses from 1" to 2".

Ref: 7482-06565: 3/16" – 3/4" / 7482-06566: 1" – 2"



Rotational table

Rotational table ideal for the unwinding of hose coils. This large diameter hose table will support your complete range of braided and spiral wire hoses.

Ref: 7480-19135



INTEGRATED FLUID POWER SOLUTIONS

THE WORLD OF GUARDS



LIFEGUARD® LINE-OF-SIGHT SLEEVING SYSTEM

THE WORLD OF GUARDS

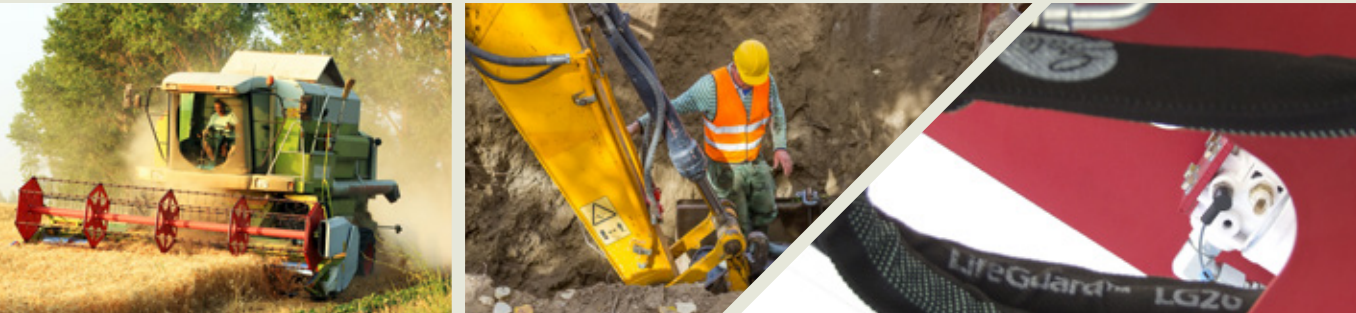

SERIOUSLY SAFE

Gates hydraulic systems don't just simply offer you peak performance, but ensure safety in your operation with the LifeGuard® Line-of-sight Sleaving System.

Unmatched operator protection

Industrial hydraulic fluid power applications are running at higher temperatures and pressures than ever before, making reliability and a safe work environment a key concern. To help you improve safety, Gates pioneered in the development of sleeving to protect operators and equipment against catastrophic hose failures or pinhole leaks. The innovative LifeGuard® Line-of-sight sleeving is the only sleeving currently available on the market that protects the equipment operator from any hose assembly located within line-of-sight. What's more, it's the only sleeve that is fully compliant to ISO 4413:2010 ("when failure of a hose assembly can constitute a fluid-ejection hazard, the hose assembly shall be shielded by suitable means").

Ensure worker's safety with top-quality sleeves

Sleeves effectively shielding operators against injury, electrical shock, mechanical failure, fires, explosions and even death, must contain bursts up to 70.0 MPa (10,000 psi) and pinhole leaks up to 35.0 MPa (5,000 psi) at 121°C for up to five minutes. To meet these requirements, the sleeve is made of several distinct nylon layers to act as your bulletproof vest.



*It's not just your everyday sleeve,
it's a safety product*

*The only true protection
for your equipment operators*



Gates LifeGuard® is the new safety standard

The state-of-the-art LifeGuard® sleeve was rigorously tested to verify its performance and capabilities. Gates goes way beyond the ISO 3457 reference standard: our test procedure and requirements recognise the real risks of hose failure in the field. These tests have proven that no other sleeve provides this level of protection thanks to our specific design features:

- › Allows fluid to safely escape down the length of the assembly
- › Creates noticeable spill for hose failure detection
- › Meets MSHA's flame resistance requirements
- › Patent pending system includes Gates hose, couplings, sleeve and channel clamps
- › Is compatible with a wide range of hydraulic fluids and biodiesel fuel
- › Flexible sleeving does not impede the flexibility of the hose assembly

Gates hydraulics, your total fluid power solution

The LifeGuard® concept perfectly adheres to the Gates Integrated System Approach, meaning we have meticulously validated and fine-tuned the channel clamps and crimp data, for best appearance and performance over most of our applicable hose lines.

ATTENTION

GUARDS

THE WORLD OF GUARDS

LIFEGUARD® 5000

Ref.	ID	EFG5K GS		EFG4K GS		M5K G		M4K G		M3K G	
		Collar	Die	Collar	Die	Collar	Die	Collar	Die	Collar	Die
14LG5K	-04					6SC-4-SS	D3234	6SC-4-SS	D3234	6SC-4-SS	D3234
16LG5K	-06	8SC-4-SS	D3436	8SC-4-SS	D3436	6PU-4-SS	D3335	6PU-4-SS	D3335	6PU-4-SS	D3335
20LG5K	-08	10SC-4-SS	D3436	10SC-4-SS	D3436	8SC-4-SS	D3436	8SC-4-SS	D3436	8SC-4-SS	D3436
22LG5K	-10	12SC-4-SS	D3638	12SC-4-SS	D3638			10SC-4-SS	D3537	10SC-4-SS	D3537
26LG5K	-12	12SC-4-SS	D3638	12SC-4-SS	D3638			12SC-4-SS	D3638	12SC-4-SS	D3638
32LG4K	-16			16SC-5-SS	D38311					16SC-5-SS	D38311

Note: for crimping the LifeGuard® 5000 sleeve with collars on the respective hose/coupling combination you can use die fingers out of existing die sets. E.g. when the product matrix is asking for D3335, you have to take 6 die fingers of die set D33 and 2 die fingers of die set D35. For more information on cutting the sleeve and assembly, please consult Gates application engineering.

- RECOMMENDED FOR** Line-of-sight protection of operators, equipment and the environment.
- MATERIAL** Three layers of super-strong nylon. Black. MSHA approved.
- TEMPERATURE RANGE** -40°C to +121°C
- CHARACTERISTICS/BENEFITS**
 - Provides containment of up to 70 MPa bursts.
 - Protects against 35 MPa pinhole leaks at +121°C for up to 5 minutes.
 - Handles hydraulic fluid and biodiesel fuels.
 - Allows fluid to safely escape down the length of the assembly.
 - Creates noticeable spill for hose failure detection.
 - Non-conductive.

IMPORTANT



Use with Gates hose, couplings and channel clamps only.

Be sure to heat the cut edges of the LifeGuard® sleeve prior to use.

Do not use LifeGuard® for abrasion and impact resistance ; use HG sleeve, metal or thermoplastic guarding instead. Should LifeGuard® become abraded it will no longer function as line-of-sight protection.

	CM2T G		G2 G		G1 G		TH8 G		TH7 G	
	Collar	Die	Collar	Die	Collar	Die	Collar	Die	Collar	Die
	6SC-4-SS	D3234	6SC-4-SS	D3234	6SC-4-SS	D3234	6SC-4-SS	D3234	6SC-4-SS	D3234
	6PU-4-SS	D3335	6PU-4-SS	D3335	6PU-4-SS	D3335	6PU-4-SS	D3335	6PU-4-SS	D3335
	8SC-4-SS	D3436	8SC-4-SS	D3436	8SC-4-SS	D3436	8SC-4-SS	D3436	8SC-4-SS	D3436
	10SC-4-SS	D3537	10SC-4-SS	D3537	10SC-4-SS	D3537				
	12SC-4-SS	D3638	12SC-4-SS	D3638	12SC-4-SS	D3638	12SC-4-SS	D3638	12SC-4-SS	D3638
	16SC-5-SS	D38311	16SC-5-SS	D38311	16SC-5-SS	D38311	16SC-5-SS	D38311	16SC-5-SS	D38311

GUARDS

THE WORLD OF GUARDS

HG NYLON SLEEVE

	A	Z	EF66K\EF65K\EF64K\EF66KL \EF65KL\EF64KL\HD-UHP	EF63K	M6K	M5K	M4K\M4KH\M4KL	M3K\M3KH	CM2T	M2T	G2\G2H\G2XH\G2L	G1\G1H	TH8	TH7
REF.	mm	mm												
HG14 NYLON SLEEVE	22.9	36.1	-6/-8		-4	-4/-5/ -6/-8	-4/-5/ -6/-8	-4/-5/ -6/-8	-4/-5/ -6/-8		-4/-5/ -6/-8	-4/-5/ -6	-4/-6	-4/-5/ -6
HG16 NYLON SLEEVE	26.9	42.4					-10	-10	-10			-8/-10	-8	-8
HG20 NYLON SLEEVE	31.0	48.8	-10				-12	-12	-12		-10	-12		-12
HG24 NYLON SLEEVE	36.1	56.9	-12								-12		-12	-16
HG28 NYLON SLEEVE	46.0	72.4	-16					-16	-16	-20	-16	-16/-20	-16	
HG32 NYLON SLEEVE	55.6	87.4	-20	-20/-24						-24	-20	-24		
HG38 NYLON SLEEVE	60.5	95.0	-24								-24			
HG42 NYLON SLEEVE	66.5	104.6								-32				
HG46 NYLON SLEEVE	73.2	115.1	-32	-32							-32	-32		
HG64 NYLON SLEEVE	111.8	175.5												

RECOMMENDED FOR Abrasion resistance for individual hoses. Maximum protection when bundling several hoses or hose assemblies together.

MATERIAL Nylon woven fabric. Black. MSHA flame-resistance approved.

TEMPERATURE RANGE: -40°C to +121°C

CHARACTERISTICS/BENEFITS 15x relative abrasion resistance over standard cover.

IMPORTANT Add 1/8" (3.18 mm) between the hose OD and the sleeve ID for installation.

Be sure to heat the cut edges of the HG Nylon Sleeve.

You may have to use a banded clamp or nylon tie to fasten the sleeve securely.

OPTIONAL



For even higher abrasion resistance check out the Gates special XtraTuff™ cover offering 25 times and the Gates special MegaTuff™ cover offering 300 times the abrasion resistance of the standard cover as per ISO 6945.

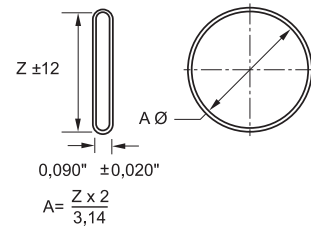

	G3H	GTH	GMV	C5CXH	MegaTech	Water Blast	Clean Master™ Pressure Wash 2WB	Clean Master™ Pressure Wash 1WB	Steam Master	Lock-On Plus	GP80+ \ GP60	GP40	GP Master	Multi Master	Plant Master™ Xtreme™ 250	Plant Master® 200 / 250 Black	Oil Master lite SD
							mm	mm	mm	mm	mm	mm	mm	mm	mm	mm	mm
	-4/-6	-4/-5/ -6/-8		-4/-6	-4/-6/ -8		8/10/ 13	6/8/ 10/13		6/10/ 13	6/8/ 10/13	6/8/ 10/13	6/8/ 10/13	6/8/ 10/13	6/10/ 13	6/10/ 13	
	-8	-10		-8/-10	-10				13	16	16	16	16	16	16	16	16
	-10	-12		-12	-8				16	19	19	19	19	19	19	19	19
	-12	-16	-12	-16	-12	-12			19			25					25
	-16		-16/-20	-20	-16/-20				25		25/32	32	25	25/32	25/32	25	32
	-20/-24		-24		-24				32 & 38		38	38		38	38		38
			-32		-32				51		51						51
			-40/-48/ -56/-64		-40/-48												65/76/ 90

Note:

New construction name	Former construction name
Plant Master™ Xtreme™ 250	Premo Flex™
Plant Master® 200 / 250 Black	Adapta Flex™ black
Clean Master™ Pressure Wash 1WB	PowerClean 1WB
Clean Master™ Pressure Wash 2WB	PowerClean 2WB

GUARDS

THE WORLD OF GUARDS

ROUND STEEL SPRING GUARD

	A	D	P	EFG6K\EFG5K\EFG4K\EFG3K EFG6KL\EFG5KL\EFG4KL\HD-UHP	M6K	M5K	M4K\M4KH\M4KL	M3K\M3KH	CM2T	M2T	G2\G2H\G2XH\G2L	G1\G1H	TH8	TH7
REF.	mm	mm	mm											
RSG 35/64" GUARD	14.0	2.0	5.6					-4						-4
RSG 43/64" GUARD	17.2	2.0	5.6		-4	-4/-5	-4/-5	-5/-6	-4/-5		-4/-5	-4/-5	-4	-5/-6
RSG 47/64" GUARD	18.7	2.0	5.6			-6	-6	-6	-6			-6		
RSG 55/64" GUARD	21.6	2.0	5.6	-6			-8	-8	-8		-6	-8	-6	-8
RSG 59/64" GUARD	23.2	2.0	5.6			-8					-8		-8	
RSG 63/64" GUARD	24.8	2.0	5.6	-8								-10		
RSG 1.3/64" GUARD	26.4	2.0	5.6				-10	-10	-10		-10			
RSG 1.1/8" GUARD	28.5	2.0	5.6	-10								-12		-12
RSG 1.9/32" GUARD	32.5	3.0	8.7	-12			-12	-12	-12		-12		-12	
RSG 1.11/32" GUARD	34.0	3.0	8.7											
RSG 1.37/64" GUARD	40.1	3.0	8.7	-16				-16	-16		-16	-16	-16	-16
RSG 1.27/32" GUARD	46.9	2.0	10.3							-20		-20		
RSG 2.7/64" GUARD	53.6	2.0	10.3	-20						-24	-20	-24		

RECOMMENDED FOR Typically used on high-pressure or other steel reinforced hoses.

MATERIAL Zinc plated round wire coil.

CHARACTERISTICS/BENEFITS Resistance to high abrasion against flat surfaces.

IMPORTANT Allow 1/32" (0.8 mm) between the hose OD and guard ID for installation.

A Ø: 00.00 mm to 22.23 mm ±0.30 mm
 22.24 mm to 30.10 mm ±0.51 mm
 30.11 mm to 101.60 mm ±0.64 mm

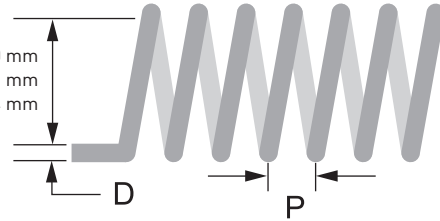

	G3H	GTH	GMV	C5CXH	MegaTech	Water Blast	Clean Master™ Pressure Wash 2WB	Clean Master™ Pressure Wash 1WB	Steam Master	Lock-On Plus	GP80+ \ GP60	GP40	GP Master	Multi Master	Plant Master™ Xtreme™ 250	Plant Master® 200 / 250 Black	Oil Master lite SD
							mm	mm	mm	mm	mm	mm	mm	mm	mm	mm	mm
		-4								6	6	6		6	6	6	
	-4	-5/-6		-5	-4		8	6/8		10	8	8	6/8	8			
				-6	-4			10			10	10		10	10	10	
	-6	-8		-8	-8		10	13		13	13	13	10	13	13	13	
				-8	-10		13						13	13	13	13	
	-8	-10		-10	-10					16		16		16	16	16	
									13		16		16	16	16	16	
	-10	-12		-12		-8				19							
			-12	-16	-12				16		19	19	19	19	19	19	19
	-12								19								
	-16	-16	-16	-20	-16	-12					25	25	25	25	25	25	25
			-20	-20	-20						32	32	32	32	32	32	32
	-24		-24		-24				32		38	38		38	38		38

Note:

New construction name	Former construction name
Plant Master™ Xtreme™ 250	Premo Flex™
Plant Master® 200 / 250 Black	Adapta Flex™ black
Clean Master™ Pressure Wash 1WB	PowerClean 1WB
Clean Master™ Pressure Wash 2WB	PowerClean 2WB

GUARDS

THE WORLD OF GUARDS

FLAT ARMOUR GUARD

	A	D	C	P	EFG6K\EF65K\EF64K\EF63K EFG6KL\EF65KL\EF64KL\HD-UHP	M6K	M5K	M4K\M4KH\M4KL	M3K\M3KH	CM2T	M2T	G2\G2H\G2XH\G2L	G1\G1H	TH8
REF.	mm	mm	mm	mm										
FLAT ARMOUR GUARD ID 0.550"	14.0	0.5	9.5	12.7										
FLAT ARMOUR GUARD ID 0.609"	15.5	0.8	6.3	9.5			-4	-4		-4		-4	-4	
FLAT ARMOUR GUARD ID 0.656"	16.7	0.5	9.5	12.7		-4	-5	-5	-5/-6	-5			-5	-4
FLAT ARMOUR GUARD ID 0.719"	18.3	0.5	9.5	12.7			-6	-6				-5	-6	
FLAT ARMOUR GUARD ID 0.797"	20.2	0.8	9.5	12.7						-6		-6		-6
FLAT ARMOUR GUARD ID 0.812"	20.6	0.7	6.4	9.5										
FLAT ARMOUR GUARD ID 0.875"	22.2	0.7	12.7	15.9	-6		-8	-8	-8	-8			-8	
FLAT ARMOUR GUARD ID 0.953"	24.2	0.7	12.7	15.9								-8	-10	-8
FLAT ARMOUR GUARD ID 1"	25.4	0.7	12.7	15.9	-8					-10				
FLAT ARMOUR GUARD ID 1.093"	27.8	0.7	12.7	15.9				-10	-10			-10		
FLAT ARMOUR GUARD ID 1.219"	31.0	0.7	12.7	15.9	-10			-12	-12	-12		-12	-12	-12
FLAT ARMOUR GUARD ID 1.562"	39.7	0.7	12.7	15.9	-12/-16				-16	-16		-16	-16	-16
FLAT ARMOUR GUARD ID 1.797"	45.6	0.7	12.7	15.9							-20		-20	
FLAT ARMOUR GUARD ID 2.093"	53.2	0.7	12.7	16.0	-20						-24	-20	-24	
FLAT ARMOUR GUARD ID 2.343"	59.5	0.7	12.7	15.9	-24							-24		
FLAT ARMOUR GUARD ID 2.875"	73.0	0.7	12.7	15.9	-32						-32	-32	-32	

RECOMMENDED FOR Typically used on high-pressure or other steel reinforced hoses.

MATERIAL Zinc plated flat steel coil.

CHARACTERISTICS/BENEFITS Resistance to high abrasion against flat surfaces.

IMPORTANT Allow 1/32" (0.8 mm) between the hose OD and guard ID for installation.

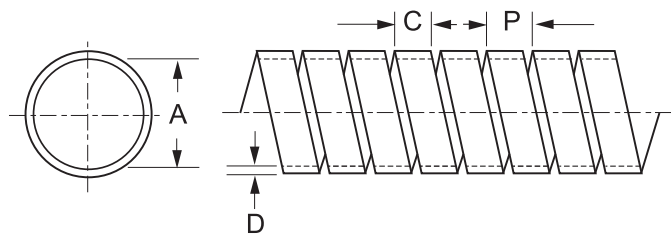

	TH7	G3H	GTH	GMV	C5CXH	MegaTech	Water Blast	Clean Master™ Pressure Wash 2WB	Clean Master™ Pressure Wash 1WB	Steam Master	Lock-On Plus	GP80+ \ GP60	GP40	GP Master	Multi Master	Plant Master™ Xtreme™ 250	Plant Master® 200 / 250 Black	Oil Master lite SD
								mm	mm	mm	mm	mm	mm	mm	mm	mm	mm	mm
																6	6	
	-5	-4	-5		-5				6					6				
			-6						8		10	8	8		8			
	-6				-6	-6		8	10			10	10	10	10	10	10	
		-6			-8			10			13			13				
			-8									13	13	13	13			13
	-8				-10			13				13	13	13	13			13
						-10					16	16	16			16	16	
	-12	-8	-10		-12	-10				13	19			16	16			
		-10			-12	-12				16		19	19	19	19	19	19	19
	-16	-12/-16	-16	-16	-16/-20	-16	-12			19		25	25	25	25	25	25	25
		-20		-20		-20				25		32	32		32	32		32
		-24		-24		-24				32		38	38		38	38		38
										38								
				-32		-32				51		51						51

Note:

New construction name	Former construction name
Plant Master™ Xtreme™ 250	Premo Flex™
Plant Master® 200 / 250 Black	Adapta Flex™ black
Clean Master™ Pressure Wash 1WB	PowerClean 1WB
Clean Master™ Pressure Wash 2WB	PowerClean 2WB

GUARDS

THE WORLD OF GUARDS

THERMOPLASTIC ARMOUR GUARD

REF.	A	D	C	EFG6K\EF65K\EF64K\HD-UHP	M6K	M5K	M4K\M4KH\M4KL	M3K/M3KH	CM2T	M2T	G2\G2H\G2XH\G2L	G1\G1H	TH8
THERMOPL. ARMOUR GUARD 1710.95	15,9	1,3	10,0		-4	-4	-4	-4/-5	-4		-4	-4	
THERMOPL. ARMOUR GUARD 1712.95	19,1	1,5	10,0			-5/-6	-5/-6	-6	-5/-6		-5	-5/-6	-4
THERMOPL. ARMOUR GUARD 1714.95	22,9	1,5	15,0	-6		-8	-8	-8	-8		-6/-8	-8	-6
THERMOPL. ARMOUR GUARD 1722.95	34,3	2,0	15,0	-8/-10/ -12			-10/- 12	-10/- 12	-10/- 12		-10/- 12	-10/- 12	-8/-12

RECOMMENDED FOR

Protects the hose against abrasive wear. Protects hose from water, air, gasoline and hydraulic fluids. Can also be used for bundling of several hydraulic hoses. Especially popular in the agricultural industry.

MATERIAL

Thermoplastic. Black.

TEMPERATURE RANGE

-40°C to +121°C.

CHARACTERISTICS/BENEFITS

Easy-to-install before and after hose assembly.
 Round edges avoiding unintentional damage to hose.
 Elastic: easily returns to original shape.
 Recyclable.

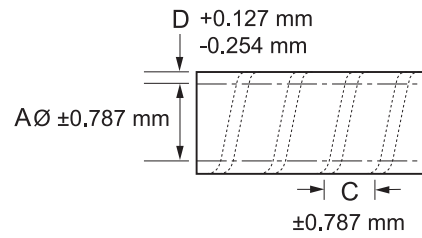

	TH7	G3H	GTH	GMV	C5CXH	MegaTech	Water Blast	Clean Master™ Pressure Wash 2WB	Clean Master™ Pressure Wash 1WB	Steam Master	Lock-On Plus	GP80+ \ GP60	GP40	GP Master	Multi Master	Plant Master™ Xtreme™ 250	Plant Master® 200 / 250 Black	Oil Master lite SD
								mm	mm	mm	mm	mm	mm	mm	mm	mm	mm	mm
	-4/-5	-4	-4/-5		-5	-4			6		6	6	8	6	6/8	6	6	
	-6		-6		-6	-6		8	8/10		10	8/10	10	8/10	10	10	10	
	-8	-6	-8		-8	-8		10/13	13		13	13	13	13	13	13	13	
	-12/-16	-8/-10/ -12	-10/-12	-12	-10/ -12/- 16	-10/-12	-8			13/16/ 19	16/19	16/19	16/19	16/19	16/19	16/19	16/19	19

Note:

New construction name	Former construction name
Plant Master™ Xtreme™ 250	Premo Flex™
Plant Master® 200 / 250 Black	Adapta Flex™ black
Clean Master™ Pressure Wash 1WB	PowerClean 1WB
Clean Master™ Pressure Wash 2WB	PowerClean 2WB



INTEGRATED FLUID POWER SOLUTIONS

ENGINEERING AND TECHNICAL DATA



SELECTING THE CORRECT HOSE

ENGINEERING AND TECHNICAL DATA

HYDRAULIC HOSE ASSEMBLY AND INDUSTRIAL HOSE SELECTION CRITERIA

An effective way to remember hose selection criteria is to remember the word STAMP, if you want to select the proper hydraulic hose assembly extend this acronym to STAMPED.

STAMPED

- S** = Size
- T** = Temperature
- A** = Application
- M** = Medium
- P** = Pressure
- E** = Ends
- D** = Delivery

Size

The **inside diameter** must be carefully chosen since an undersized hose diameter leads to increased pressure loss and heat generation by excessive turbulence of the hydraulic fluid. Oversizing the hose, however, adds unnecessary cost, weight and bulk.

To determine the replacement hose size, read the layline printing on the side of the original hose. If the original hose layline is painted over or worn off, cut the original hose and measure the inside diameter for size.

The hose **outside diameter** (O.D.) can be a critical factor when hose routing clamps are used or hoses are routed through bulkheads. Check individual hose specification tables for O.D.'s.

Temperature

Both fluid temperature and ambient temperature must be considered. The hose selected must be capable of withstanding the surrounding minimum and maximum temperature of the environment, as well as the maximum temperature of the system. When hoses are exposed to an extremely high ambient temperature or hot equipment parts, insulating sleeves or a heat shield to protect the hose are recommended.

Application

When designing a system or replacing a hose line, every aspect of the application has to be considered. Make sure all requirements of the application are fulfilled for the best fit. The type of equipment, working and surge pressures, environmental conditions, routing requirements and expected service life are the most obvious ones, but note there is much more that can impact the right choice of a hose assembly and optimal functioning of the system. Conditions such as ozone and chemical vapours, vibrations, movement of machine parts and unusual mechanical loads, electrical conductivity requirements, government and industry standards, excessive abrasion....

Medium

Some applications require specialised oils or chemicals to be conveyed through the system. Hose selection must assure compatibility of the hose tube, cover, couplings and 'O' rings with the fluid used. Attention is due to the chemical name(s) and state(s) – liquid, solid or gas, concentration. See page 579 on "Material to be conveyed" and the "Chemical resistance table" for further guidance.

Pressure

In the hose selection process it is essential to know the system pressure, including pressure spikes. Published working pressures of the hoses must be equal or greater than the system pressure. Pressure spikes greater than the published working pressure significantly shorten hose life.

To minimise hose failure, the hydraulic hose has a build-in safety factor which is specified by the ratio between the burst pressure and the maximum working pressure. This ratio equals 4/1 as specified in the ISO 7751 standard. Also take care of hydraulic system pressure drop on page 580.

Ends (couplings)

To identify the right end connection, note that a hose coupling consists of two functional ends:

- › **The hose/coupling interface** to connect the hose with the coupling.
The coupling must be designed and tested to assure optimal grip to hose cover, wire and tube and to perform to the applicable international standards.
- › **The coupling termination** to connect the hose assembly to the equipment port or adaptor.
Different termination types exist and offer different sealing solutions. This can be done via mating thread, cone, O-ring, flange end... As the market becomes more global, it is important to recognise and identify its differences and features. International thread ends can be metric (measured in millimetres), American or British Standard Pipe (measured in inches), while Japanese or Korean machine manufacturers often use JIS (Japanese Industrial Standard), measured in millimetres as well. The coupling seat (inverted, regular or flat), the seat angle (30°, 12°) and thread (imperial or metric, parallel or tapered) are determined by the termination type like DIN, SAE, JIC, BSP according to ISO 12151.

Selecting the correct coupling on page 582 - 597 provides further details.

Delivery (flow rate)

The amount of fluid that must pass through a hose determines the size of the hose needed. Velocity of hydraulic fluid should always fall within a specific range. ISO 4413 standard recommends the flow velocity not to be over 5m/s. When the flow rate is known, the hose bore can be determined easily with the help of the nomographic chart, see page 578.

SELECTING THE CORRECT HOSE

ENGINEERING AND TECHNICAL DATA

HOSE SIZE SELECTION NOMOGRAM

How to use the nomographic chart

To determine the recommended hose assembly size where the flow rate is known, lay a straight edge across the three columns so that the edge registers with the flow rate figure in the left hand scale, and the recommended velocity range in the right hand scale. The point at which the straight edge intersects the centre scale indicates the recommended hose bore size.

Should this reading not coincide with a standard hose assembly bore size, the right hand edge of the straight edge may be adjusted up or down, within the recommended velocity range, until the straight edge registers with a standard bore size in the centre scale.

EXAMPLE

Where flow rate is 100 litres per minute and recommended flow velocity is 4.5 metres per second a 25 mm (1 inch) bore size hose assembly is indicated.

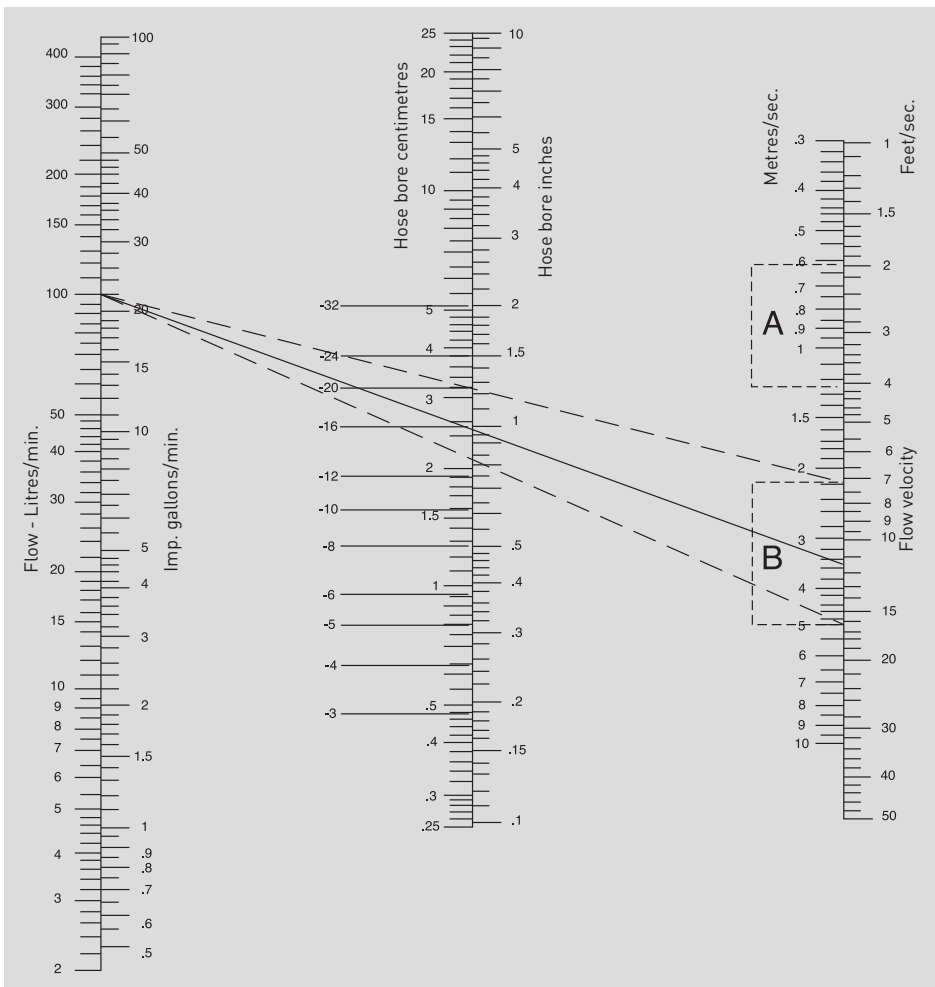

NOTE

Flow velocities in range A are recommended for suction and return lines.
Flow velocities in range B are recommended for delivery lines.
ISO 4413 standard recommends flow velocity not to be over 5 m/s.

MATERIAL TO BE CONVEYED

Some applications require specialised oils or chemicals to be conveyed through the system. Product selection must assure compatibility of the hose tube, cover, couplings and 'O' rings with the fluid used. Additional caution must be exercised when selecting a hose for gaseous applications where permeation can occur. Permeation of fluid through the hose wall may occur when a hose is used in combination with fluids such as (but not limited to) liquid and gas fuels, refrigerants, helium, fuel oil, natural gas, LPG and Freon.

Consider the possibility of hazardous effects of permeation through the hose, such as explosions, fires and toxicity. Refer to applicable standards for specific applications such as fuels and refrigerants. If fluids permeate through the hose tube, consider the use of perforated covers to prevent fluid build-up under the cover. Also ensure the compatibility of the system fluid not only with the hose tube, but also with the reinforcement, cover, fittings and other components since permeation may expose the entire hose assembly to the system fluid.

Biodegradable fluids

Traditionally, most common hydraulic fluids are petroleum-based oils. For applications in environmentally sensitive areas, the industry is now moving towards more environmentally friendly fluids, either synthetic (primarily ester based) or vegetable based. Vegetable oils are gaining ground over synthetic ones because they cost less and biodegrade faster.

The challenge of biodegradable fluids? They easily permeate ordinary hose tubes, causing blisters and sweating on the cover of the hose, with premature hose failure as a consequence. Selecting the hose with the proper tube compound is key in assuring full compatibility to handle also the aggressive environmentally-safe hydraulic fluids.

Vegetable based oils usually have good compatibility with rubber hose products whereas synthetic ester oils are more aggressive and must be used with caution. General compatibility guidelines for rubber hoses are as follows:

	Vegetable based	Synthetic ester based
Spiral reinforced hose GxK	generally OK	caution
Spiral reinforced hose EFGxK	OK	generally OK
Wire braid hose	OK	generally OK
Textile braid hose	OK	generally OK

RECOMMENDED BIODEGRADABLE FLUIDS:

- > Shell Naturelle HF-E46 - Synthetic ester
- > IRM901 - Paraffinic mineral oil
- > Binol Hydrap - Rape seed oil
- > Elf Oil 15W40 - Engine 0.1
- > Hydrolub Bio 46 - Synthetic ester
- > IGOL MATIC 259 - Mineral oil

Please contact Gates application engineering department for further fluid compatibility tests for your specific fluid.

SELECTING THE CORRECT HOSE

ENGINEERING AND TECHNICAL DATA

Water temperature limits for hydraulic hoses

According to ISO 8330 "Rubber and plastic hoses and hose assemblies - Vocabulary", the working temperature is the "maximum or minimum temperature at which a hose is designed to be serviceable". This temperature range is indicated in the hose pages. However, note that the nature of the hydraulic fluid used can lower the maximum working temperature. The below chart shows the maximum working temperature for Gates hoses when used with water-based hydraulic fluids.

The main reasons for lowering maximum working temperatures of hydraulic systems using water-based hydraulic fluids are:

- > Hot water can leach the plasticiser out of the rubber compound, whereby the hose becomes stiff and brittle.
- > Heated water even under pressure can de-gas and cause gas bubbles. These gas bubbles contain about 20% oxygen which will lead to oxidation of the metal parts of the system.
- > Mixed phases of hot water and steam can occur, which causes several issues like tube popcorning, permeation of steam through the walls of the hose and even steam hammer.

Maximum Temperature limits for Water, Water/Oil Emulsions and Water/Glycol Solutions.

HOSE	Pressure lines	Return lines
EF6xK, MxK, HD-UHP, CM2T, M2T, G2, G1, G2L, LOL, EFGxKL, M4KL, GP80 PLUS	+93°C	+82°C
G2H, G1H, Megatech, G2XH, G3H, GTH, M4KH, M3KH, GMV	+107°C	+82°C
TH8, TH7	+70°C	+70°C

CAUTION!

The fluid manufacturer's recommended maximum temperature for any given fluid must not be exceeded. If different from the above listed hose temperatures, the lower limit must be chosen.

HYDRAULIC SYSTEM PRESSURE DROP

Pressure

Factors that can influence the amount of pressure drop:

> Friction

This is the turbulence of fluid against the inside walls of the hose assembly and within itself generating heat and causing pressure drop.

> Type of fluid

Different fluids behave differently under pressure. Thicker fluids are moved with greater difficulty and will exhibit greater pressure drop because of greater friction loss.

> Temperature of the fluid

Warming fluids thins them, so they are moved more easily.

> Length of hose assembly

The longer the hose assembly, the more surface area there is for friction to decrease pressure.

> Size (I.D.) of hose

Affects the fluid velocity for a given flow rate. Higher velocities result in greater pressure drop. Therefore, a larger I.D. hose will produce less pressure drop.

> Type of couplings and adaptors

Any change in bore or change in direction (such as with 45° or 90° elbow) can increase the amount of pressure drop. So keep hose assembly routing as smooth as possible.

> Flow rate

Pressure drop increases with flow rate for the same size hose.

Why is knowing the amount of pressure drop so important?

Suppose you need 275 bar of output from a hose assembly for hydraulic equipment to run efficiently. There will be some pressure drop and you must allow for it in plumbing the system with hose, couplings and adaptors. This means that the input pressure to the hose assembly must be equal to the output, plus the amount of pressure drop. If the pressure drop in this example is 10 bar, then you will need 285 bar of input.

$$\text{Output pressure} = \text{input pressure} - \text{pressure drop}$$

$$275 \text{ bar} = 285 \text{ bar} - 10 \text{ bar}$$

How can you determine the amount of pressure drop?

The best way is to contact your Gates representative who is trained and equipped to quickly solve such problems for you. He will need the following information: type of application, fluid type and viscosity (at desired temperature), fluid temperature, fluid flow rate, hose size and length, number and type of fittings. The following graph will also help you to determine the amount of pressure drop.

Hose pressure drop

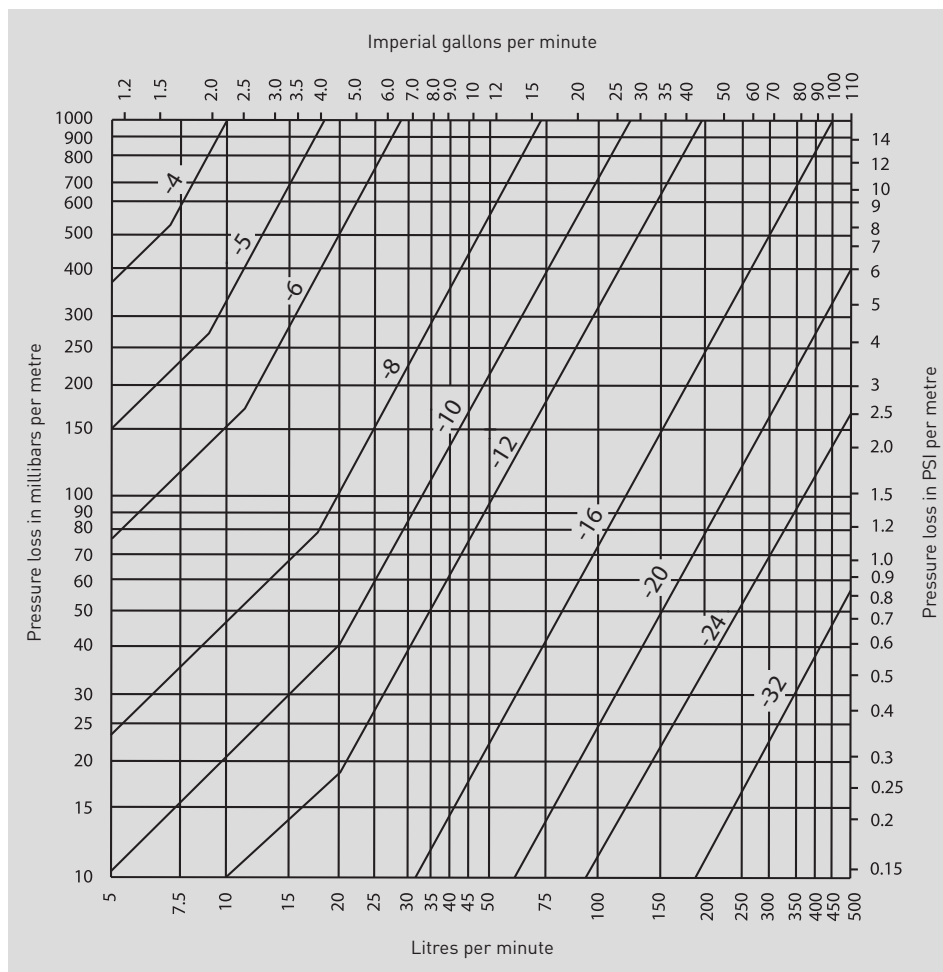

Based on: fluid viscosity 20 cSt
specific gravity 0.875

SELECTING THE CORRECT COUPLING

ENGINEERING AND TECHNICAL DATA

COUPLING SELECTION CRITERIA

Several factors, such as thread end compatibility, corrosion resistance, vibration, temperature, pressure, use of adaptors and fluid compatibility must be considered when selecting a coupling:

Thread end compatibility

Thread ends must be compatible in order to prevent leaking or assembly blowoff. Fittings seal three ways: thread interface, seat angles and/or 'O' rings. It is critical that both the male and female fittings are compatible to ensure an effective seal. Incorrect sealing will cause leaks, which can represent a safety and environmental hazard. For detailed explanation of thread identification see page 265.

Temperature

Metal surfaces can expand and contract under extreme temperature fluctuations. Choose couplings with 'O' rings for sealing. The 'O' ring will seal as the metal moves. It may be necessary to use 'O' ring materials that are suitable for high temperatures.

Fluid compatibility

Hydraulic hose is commonly selected by its compatibility with fluid, while couplings usually are not. However, 'O' rings (generally nitrile) can also be affected and need to be checked for fluid compatibility (see page 86).

Corrosion resistance

Gates hydraulic fittings are manufactured from carbon steel and are plated for excellent corrosion resistance. Other materials such as stainless steel are also used.

Pressure

Working pressure should be a consideration when selecting a fitting. Some fittings do not seal well at high pressures and can develop a leak. 'O' ring type fittings as well as solid port connectors work well at high pressures.

Vibration

Coupling selection may be influenced by motion and/or vibration at the end connection, which can potentially weaken or loosen a connection. Split flange couplings, or other couplings containing an 'O' ring for sealing, perform better under vibration. Avoid use of couplings that seal on the threads.

Use of adaptors

Some couplings connect directly to a port, while others need adaptors. This can influence coupling selection. Connecting directly to the port eliminates the need for an additional connection, but can make installation more difficult. Adaptors can make installation easier and eliminate the need for coupling orientation, but introduce an additional connection or possible leak point.

COUPLING IDENTIFICATION

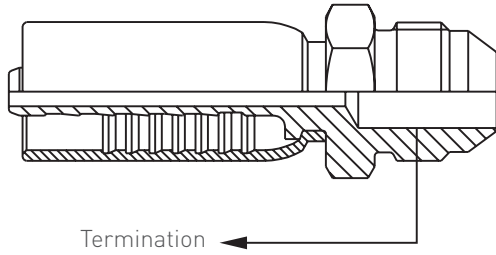

	Male thread	Female thread	No thread
Metric	MDL / MDH	FDLORX / FDHORX	MSP
	MFG		FPFL
		FFGX	MPFL
			DBJ
BSP (British Standard Pipe)	MBSPT	FBSPORX	BSPBJ
	MBSPP	FBFFX	
	MBFF		
JIC (Joint Industrial Council)	MJ	FJX	
SAE (Society of Automotive Engineers)	MFFOR	FFORX	FL
	MFA	FSX	FLH
	MS		
	MB		
	MBX		
NPTF (American Standard Pipe Taper Fuel)	MP		
	MPX		
UNS (Unified National Special)	MIX		
Japanese metric		FKX	FLK
JIS (Japanese Industrial Standard)		FJISX	

SELECTING THE CORRECT COUPLING



ENGINEERING AND TECHNICAL DATA

FEMALE COUPLINGS

BSP FBSPORX

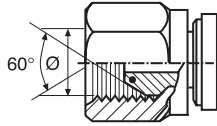
Female BSP 'O' ring swivel.
60° cone.





			
	Thread size	Threads/inch	mm
04FBSPORX	1/4" - 19	19	11.7
06FBSPORX	3/8" - 19	19	15.2
08FBSPORX	1/2" - 14	14	18.9
10FBSPORX	5/8" - 14	14	20.9
12FBSPORX	3/4" - 14	14	24.4
16FBSPORX	1" - 11	11	30.6
20FBSPORX	1.1/4" - 11	11	39.3
24FBSPORX	1.1/2" - 11	11	45.2
32FBSPORX	2" - 11	11	59.5

JIS FJISX

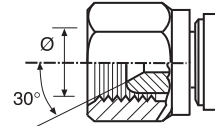
Female Japanese swivel.
30° inverted cone.
BSP thread.





			
	Thread size	Threads/inch	mm
04FJISX	1/4" - 19	19	11.7
06FJISX	3/8" - 19	19	15.2
08FJISX	1/2" - 14	14	18.9
12FJISX	3/4" - 14	14	24.4
16FJISX	1" - 11	11	30.6

JIS FKX

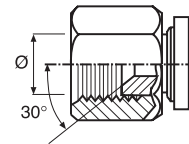
Female Japanese swivel.
30° inverted cone.
Metric thread.





			
	Thread size	mm	
04FKX	M14 x1.5	12.5	
06FKX	M18 x1.5	16.5	
08FKX	M22 x1.5	20.5	
10FKX	M24 x1.5	22.5	
12FKX	M30 x1.5	28.5	
16FKX	M33 x1.5	31.5	
20FKX	M36 x1.5	34.5	

BSP FBFFX

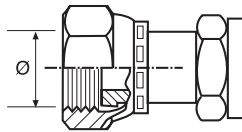
Female BSP flat face swivel.



			
	Thread size	Threads/inch	mm
06FBFFX	3/8" - 19	19	15.2
08FBFFX	1/2" - 14	14	18.9
10FBFFX	5/8" - 14	14	20.9
12FBFFX	3/4" - 14	14	24.4

SAE FFORX

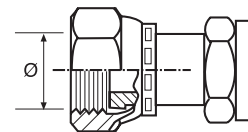

Female SAE flat face 'O' ring swivel.



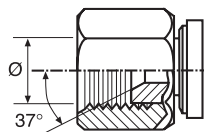

JIC FJX

Female JIC swivel.
37° inverted cone.







			
	Thread size	Threads/inch	mm
04FJX	7/16" - 20	20	9.9
05FJX	1/2" - 20	20	11.5
06FJX	9/16" - 18	18	12.9
08FJX	3/4" - 16	16	17.5
10FJX	7/8" - 14	14	20.5
12FJX	1.1/16" - 12	12	25.0
14FJX	1.3/16" - 12	12	28.2
16FJX	1.5/16" - 12	12	31.3
20FJX	1.5/8" - 12	12	39.2
24FJX	1.7/8" - 12	12	45.5
32FJX	2.1/2" - 12	12	61.4

			
	Thread size	Threads/inch	mm
04FFORX	9/16" - 18	18	12.9
06FFORX	11/16" - 16	16	15.9
08FFORX	13/16" - 16	16	19.1
10FFORX	1" - 14	14	23.6
12FFORX	1.3/16" - 12	12	28.0
16FFORX	1.7/16" - 12	12	34.4
20FFORX	1.11/16" - 12	12	40.7
24FFORX	2" - 12	12	48.7

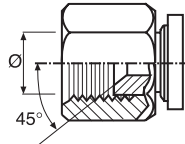
SAE FSX

Female SAE swivel.
45° inverted cone.





			Thread size	Threads/inch	mm	
			04FSX	7/16" - 20	20	9.9
			05FSX	1/2" - 20	20	11.5
			06FSX	5/8" - 18	18	15.7
			08FSX	3/4" - 16	16	17.5
			10FSX	7/8" - 14	14	20.5
			12FSX	1.1/16" - 14	14	25.2

FDLORX / FDHORX

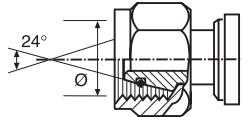
Female DIN 'O' ring swivel.
24° cone.
Light series / Heavy series.





			Thread size	Threads mm	Tube mm	Series	
			06FDLORX	12 x 1.5	10.5	6	L
			06FDHORX	14 x 1.5	12.5	6	S
			08FDLORX	14 x 1.5	12.5	8	L
			08FDHORX	16 x 1.5	14.5	8	S
			10FDLORX	16 x 1.5	14.5	10	L
			10FDHORX	18 x 1.5	16.5	10	S
			12FDLORX	18 x 1.5	16.5	12	L
			12FDHORX	20 x 1.5	18.5	12	S
			14FDLORX	20 x 1.5	18.5	14	L
			14FDHORX	22 x 1.5	20.5	14	S
			15FDLORX	22 x 1.5	20.5	15	L
			16FDHORX	24 x 1.5	22.5	16	S
			18FDLORX	26 x 1.5	24.5	18	L
			20FDHORX	30 x 2.0	28.0	20	S
			22FDLORX	30 x 2.0	28.0	22	L
			25FDHORX	36 x 2.0	34.0	25	S
			28FDLORX	36 x 2.0	34.0	28	L
			30FDHORX	42 x 2.0	42.0	30	S
			35FDLORX	45 x 2.0	43.0	35	L
			38FDHORX	52 x 2.0	50.0	38	S

FG FFGX

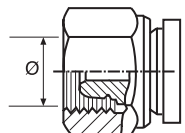
Female French Gaz swivel.
24° cone.





			Thread size	Threads mm	mm	
			13FFGX	20 x 1.5	18.5	13.25
			17FFGX	24 x 1.5	22.5	16.75
			21FFGX	30 x 1.5	28.5	21.25
			27FFGX	36 x 1.5	34.5	26.75
			34FFGX	45 x 1.5	43.5	33.50
			42FFGX	52 x 1.5	50.5	42.25

DIN FDLX / FDHX

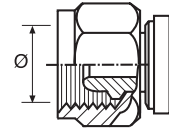
Female DIN swivel. 24°/60° cone.
Light series / Heavy series.





			Thread size	Threads mm	Tube mm	Series	
			06FDLX	12 x 1.5	10.5	6	L
			08FDLX	14 x 1.5	12.5	8	L
			08FDHX	16 x 1.5	14.5	8	S
			10FDLX	16 x 1.5	14.5	10	L
			10FDHX	18 x 1.5	16.5	10	S
			12FDLX	18 x 1.5	16.5	12	L
			12FDHX	20 x 1.5	18.5	12	S
			14FDHX	22 x 1.5	20.5	14	S
			15FDLX	22 x 1.5	20.5	15	L
			16FDHX	24 x 1.5	22.5	16	S
			18FDLX	26 x 1.5	24.5	18	L
			20FDHX	30 x 2.0	28.0	20	S
			22FDLX	30 x 2.0	28.0	22	L
			28FDLX	36 x 2.0	34.0	28	L

NPTF FPX

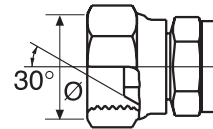
Female NPSM pipe swivel.
30° cone.





			Thread size	Threads/inch	mm	
			04FPX	1/4" - 18	18	9.1
			06FPX	3/8" - 18	18	11.9
			08FPX	1/2" - 14	14	15.5
			12FPX	3/4" - 14	14	19.1
			16FPX	1" - 11.5	11.5	30.7

NPTF FP

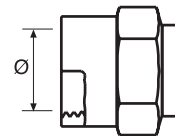
Female NPTF pipe.



		Thread size	Threads/inch	
		02FP	1/8" - 27	28
		04FP	1/4" - 18	18
		06FP	3/8" - 18	18
		08FP	1/2" - 14	14
		12FP	3/4" - 14	14

SELECTING THE CORRECT COUPLING



ENGINEERING AND TECHNICAL DATA

MALE COUPLINGS

BSP MBSPT

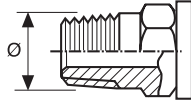
Male BSP taper.





			
	Thread size	Threads/inch	mm
04MBSPT	1/4" - 19	19	13.6
06MBSPT	3/8" - 19	19	17.1
08MBSPT	1/2" - 14	14	21.5
10MBSPT	5/8" - 14	14	23.4
12MBSPT	3/4" - 14	14	27.0
16MBSPT	1" - 11	11	33.9

BSP MBSPP

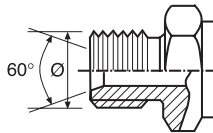
Male BSP parallel.
60° inverted cone.





			
	Thread size	Threads/inch	mm
04MBSPP	1/4" - 19	19	13.0
06MBSPP	3/8" - 19	19	16.5
08MBSPP	1/2" - 14	14	20.8
10MBSPP	5/8" - 14	14	22.8
12MBSPP	3/4" - 14	14	26.3
16MBSPP	1" - 11	11	33.1
20MBSPP	1.1/4" - 11	11	41.8
24MBSPP	1.1/2" - 11	11	47.7

BSP MBFF

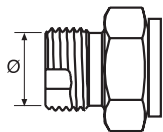
Male BSP flat face.





			
	Thread size	Threads/inch	mm
08MBFF	1/2" - 14	14	20.8

JIC 37° MJ

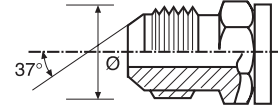
Male JIC parallel.
37° cone.





			
	Thread size	Threads/inch	mm
04MJ	7/16" - 20	20	11.0
05MJ	1/2" - 20	20	12.5
06MJ	9/16" - 18	18	14.1
08MJ	3/4" - 16	16	18.9
10MJ	7/8" - 14	14	22.1
12MJ	1.1/16" - 12	12	26.9
14MJ	1.3/16" - 12	12	30.0
16MJ	1.5/16" - 12	12	33.2
20MJ	1.5/8" - 12	12	41.2
24MJ	1.7/8" - 12	12	47.5
32MJ	2.1/2" - 12	12	63.3

SAE MFFOR

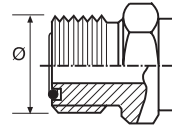
Male SAE flat face 'O' ring.





			
	Thread size	Threads/inch	mm
04MFFOR	9/16" - 18	18	14.1
06MFFOR	11/16" - 16	16	17.3
08MFFOR	13/16" - 16	16	22.0
10MFFOR	1" - 14	14	25.3
12MFFOR	1.3/16" - 12	12	30.0
16MFFOR	1.7/16" - 12	12	36.3
20MFFOR	1.11/16" - 12	12	42.6

SAE 45° MS

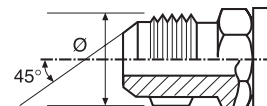
Male SAE parallel.
45° cone.





			
	Thread size	Threads/inch	mm
04MS	7/16" - 20	20	11.0
06MS	5/8" - 18	18	15.7
08MS	3/4" - 16	16	18.9
10MS	7/8" - 14	14	22.1
12MS	1.1/16" - 14	14	26.9

SAE 45° MIX

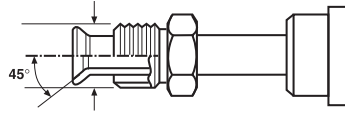
Male SAE parallel.
45° inverted cone.





			
	Thread size	Threads/inch	mm
04MIX	7/16" - 24	24	11.0
05MIX	1/2" - 20	20	12.5
06MIX	5/8" - 18	18	15.7
07MIX	11/16" - 18	18	17.3
08MIX	3/4" - 18	18	18.9

SAE 24° MFA

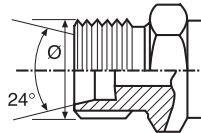
Male SAE parallel.
24° inverted cone.





			
	Thread size	Threads/inch	mm
04MFA	7/16" - 20	20	11.0
05MFA	1/2" - 20	20	12.5
06MFA	9/16" - 18	18	14.1
08MFA	3/4" - 16	16	18.9
10MFA	7/8" - 14	14	22.1
12MFA	1.1/16" - 12	12	26.9
16MFA	1.5/16" - 12	12	33.2

DIN 24° MDL / MDH

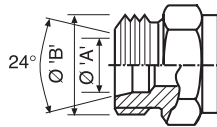
Male DIN parallel.
24° inverted cone.
Light / Heavy series.





				
	Thread size	A mm	B mm	
06MDL	12 x 1.5	6	12	
08MDL	14 x 1.5	8	14	
08MDH	16 x 1.5	8	16	
10MDL	16 x 1.5	10	16	
10MDH	18 x 1.5	10	18	
12MDL	18 x 1.5	12	18	
12MDH	20 x 1.5	12	20	
14MDH	22 x 1.5	14	22	
15MDL	22 x 1.5	15	22	
16MDH	24 x 1.5	16	24	
18MDL	26 x 1.5	18	26	
20MDH	30 x 2.0	20	30	
22MDL	30 x 2.0	22	30	
25MDH	36 x 2.0	25	36	
28MDL	36 x 2.0	28	36	
30MDH	42 x 2.0	30	42	
35MDL	45 x 2.0	35	45	
38MDH	52 x 2.0	38	52	

NPTF MP

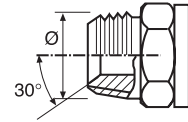
Male NPTF pipe.





			
	Thread size	Threads/inch	mm
02MP	1/8" - 27	27	10.3
04MP	1/4" - 18	18	13.9
06MP	3/8" - 18	18	17.3
08MP	1/2" - 14	14	21.6
12MP	3/4" - 14	14	26.9
16MP	1" - 11.5	11.5	33.7
20MP	1.1/4" - 11.5	11.5	42.5
24MP	1.1/2" - 11.5	11.5	48.6
32MP	2" - 11.5	11.5	60.7

NPTF MPX

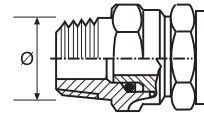
Male NPTF pipe swivel.





			
	Thread size	Threads/inch	mm
04MPX	1/4" - 18	18	13.9
06MPX	3/8" - 18	18	17.3
08MPX	1/2" - 14	14	21.6
12MPX	3/4" - 14	14	26.9
16MPX	1" - 11.5	11.5	33.7

UNF MB

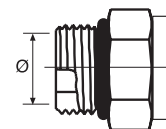
Male SAE 'O' ring boss.



			
	Thread size	Threads/inch	mm
04MB	7/16" - 20	20	11.0
05MB	1/2" - 20	20	12.5
06MB	9/16" - 18	18	14.1
08MB	3/4" - 16	16	18.9
10MB	7/8" - 14	14	22.1
12MB	1.1/16" - 12	12	26.9
14MB	1.3/16" - 12	12	30.0
16MB	1.5/16" - 12	12	33.2
20MB	1.5/8" - 12	12	41.2



SELECTING THE CORRECT COUPLING

ENGINEERING AND TECHNICAL DATA

UNF MBX

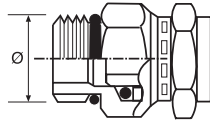
Male SAE 'O' ring boss swivel.





			
	Thread size	Threads/inch	mm
06MBX	9/16" - 18	18	14.1
08MBX	3/4" - 16	16	18.9
10MBX	7/8" - 14	14	22.1
12MBX	1.1/16" - 12	12	26.9

KOBELCO MKB

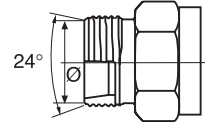
Male Kobelco type.





			
	Thread size	Threads/inch	mm
22MKB	30 x 1.5	22	30
28MKB	36 x 1.5	28	36
35MKB	45 x 1.5	35	45

FG MFG

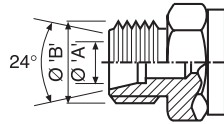
Male French Gaz parallel.
24° inverted cone.





			
	Thread size	A mm	B mm
13MFG	20 x 1.5	13.2	20.0
17MFG	24 x 1.5	16.9	24.0
21MFG	30 x 1.5	21.4	30.0
27MFG	36 x 1.5	26.9	36.0
34MFG	45 x 1.5	33.7	45.0
42MFG	52 x 1.5	42.4	52.0

BANJO COUPLINGS

BSP BSPBJ

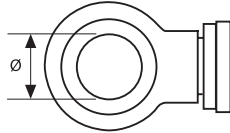
BSP banjo.





		
	mm	Bolt thread size
04BSPBJ	13.2	1/4" BSP
06BSPBJ	16.8	3/8" BSP
08BSPBJ	21.0	1/2" BSP
12BSPBJ	26.5	3/4" BSP

DIN DBJ

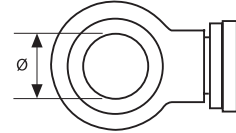
Metric banjo.





		
	mm	Bolt thread size
10DBJ	10.1	M10
12DBJ	12.1	M12
14DBJ	14.1	M14
16DBJ	16.1	M16
18DBJ	18.1	M18
22DBJ	22.1	M22
26DBJ	26.1	M26
30DBJ	30.1	M30

STANDPIPE COUPLINGS

METRIC MSP

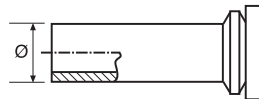
DIN metric standpipe.



		
	mm	Series
06MSP	6	L
08MSP	8	L
10MSP	10	L
12MSP	12	L
15MSP	15	L
18MSP	18	L
22MSP	22	L

SELECTING THE CORRECT COUPLING

ENGINEERING AND TECHNICAL DATA

FLANGE COUPLINGS

SAE FL

SAE 'O' ring flange.
Code 61.

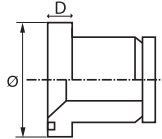

	Nominal size	Ø mm	D mm
08FL	1/2"	30.2	6.8
12FL	3/4"	38.1	6.8
16FL	1"	44.5	8.0
20FL	1.1/4"	50.8	8.0
24FL	1.1/2"	60.3	8.0
32FL	2"	71.4	9.6

SAE FLH

SAE 'O' ring flange high-pressure.
Code 62.

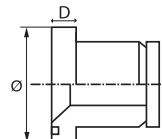

	Nominal size	Ø mm	D mm
08FLH	1/2"	31.8	7.8
12FLH	3/4"	41.3	8.8
16FLH	1"	47.6	9.5
20FLH	1.1/4"	54.0	10.3
24FLH	1.1/2"	63.5	12.6
32FLH	2"	79.4	12.6

FLK

Komatsu type
'O' ring flange.

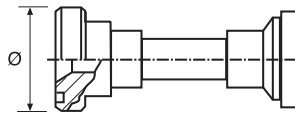

	Nominal size	Ø mm
10FLK	5/8"	34.2

FLC

Caterpillar type 'O' ring flange.

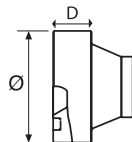

	Nominal size	Ø mm	D mm
12FLC	3/4"	41.4	14.2
16FLC	1"	47.6	14.2
20FLC	1.1/4"	54.0	14.2
24FLC	1.1/2"	63.5	14.2
32FLC	2"	79.5	14.2

FG FPFL

Female French Gaz flange high-pressure.
24° Poclairn inverted cone.

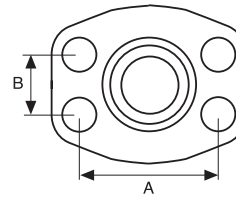

	A mm	B mm
17FPFL	40.0	18.2
21FPFL	40.0	18.2
27FPFL	50.8	23.8
34FPFL	57.3	27.3

FG MPFL

Male French Gaz flange high-pressure.
24° Poclairn cone.

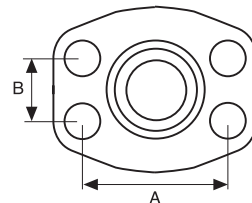

	A mm	B mm
17MPFL	40.0	18.2
21MPFL	40.0	18.2
27MPFL	50.8	23.8
34MPFL	57.3	27.3

'O' RINGS

-size	FBSPORX 70 / ** 80 SHORE mm	MFFOR 90 SHORE mm	FL 70 SHORE mm	FLH 90 SHORE mm	PWSP 90 SHORE mm	FPWX 90 SHORE mm
-4	5.5 x 1	7.65 x 1.78			7.1 x 1.6	10.0 x 2.0
-5		8.50 x 1.78			7.1 x 1.6	10.0 x 2.0
-6	7.1 x 1.6	9.25 x 1.78			7.1 x 1.6	10.0 x 2.0
-8	11.1 x 1.6	12.42 x 1.78	18.64 x 3.53	18.64 x 3.53		
-10	12.1 x 1.6	15.6 x 1.78				
-12	15.1 x 1.6	18.77 x 1.78	24.99 x 3.53	24.99 x 3.53		
-16	20.1 x 1.6	23.52 x 1.78	32.92 x 3.53	32.92 x 3.53		
-20	27.1 x 1.6	29.87 x 1.78	37.69 x 3.53	37.69 x 3.53		
-24	32.1 x 1.6 **		47.22 x 3.53	47.22 x 3.53		
-32	44.17 x 1.78		56.75 x 3.53	56.75 x 3.53		

Tube mm	FDHORX 90 SHORE mm	FDLORX 90 SHORE mm
6	4.0 x 1.5	4.0 x 1.5
8	6.0 x 1.5	6.0 x 1.5
10	7.5 x 1.5	7.5 x 1.5
12	9.0 x 1.5	9.0 x 1.5
14	10.0 x 2.0 *	
15		12.0 x 2.0
16	12.0 x 2.0	
18		15.0 x 2.0
20	16.3 x 2.4	
22		20.0 x 2.0
25	20.3 x 2.4	
28		26.0 x 2.0
30	25.3 x 2.4	
35		32.0 x 2.5
38	33.3 x 2.4	
42		38.0 x 2.5

'O' rings meet dimensional requirements of ISO 8434-1 & 8434-4

* 'O' ring dimensions for 14mm tube meet DIN 3865

SELECTING THE CORRECT COUPLING

ENGINEERING AND TECHNICAL DATA

EASY IDENTIFICATION OF METRIC COUPLINGS

New applications for metric couplings

For all new metric applications always use the FDLORX or FDHORX Soft Seal couplings. The Soft Seal 'O' ring in the coupling cone provides additional sealing capability at the termination, at the initial startup as well as during the entire service life of the machine.



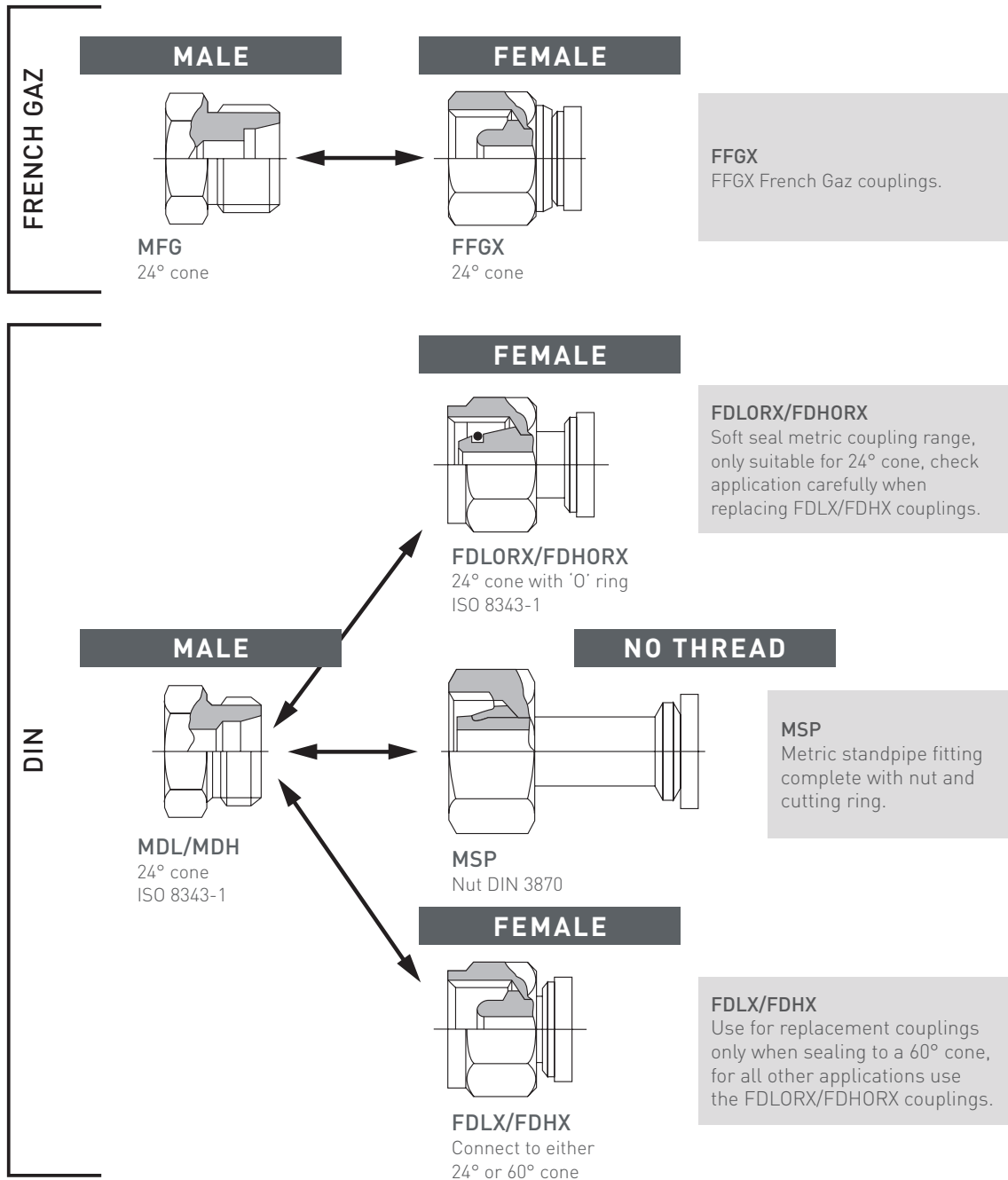



Vibrations cause the nuts to de-torque, therefore regular maintenance is required to prevent possible leak paths. Gates Soft Seal 'O' rings are not sensitive to vibration, therefore providing longer periods of cone-to-port sealing.









SELECTING THE CORRECT COUPLING

ENGINEERING AND TECHNICAL DATA







THREAD SIZE IDENTIFICATION GUIDE

								
9.1								
9.9								
10.3				1/8"-27 NPTF	2MP			
10.5								
11.0			7/16"-20 UNF 7/16"-20 UNF	4MJ 4MS	7/16"-24 UNS 7/16"-20 UNF	4MIX 4MFA	7/16"-20 UNF	4MB
11.5								
11.7								
11.9								
12.0					M12 x 1.5	6MDL		
12.5			1/2"-20 UNF	5MJ	1/2"-20 UNF 1/2"-20 UNF	5MIX 5MFA	1/2"-20 UNF	5MB
12.9								
13.0					1/4"-19 BSP	4MBSPP		
13.6	1/4"-19 BSP	4MBSPT						
13.9					1/4"-18 NPTF	4MP		
14.0					M14 x 1.5	8MDL		
14.1			9/16"-18 UNF	6MJ	9/16"-18 UNF	6MFA	9/16"-18 UNF 9/16"-18 UNF 9/16"-18 UNF	6MB 4MFFOR 6MBX
14.5								
15.2								
15.5								
15.7			5/8"-18 UNF	6MS	5/8"-18 UNF	6MIX		
15.9								
16.0					M16 x 1.5 M16 x 1.5 3/8"-19 BSP	8MDH 10MDL 6MBSPP		
16.5								
17.1	3/8"-19 BSP	6MBSPT						
17.3					3/8"-18 NPTF 11/16"-18 UNS	6MP 7MIX	11/16"-16 UN	6MFFOR
17.5								
18.0					M18 x 1.5 M18 x 1.5	10MDH 12MDL		
18.5								
18.9			3/4"-16 UNF 3/4"-16 UNF	8MJ 8MS	3/4"-18 UNS 3/4"-16 UNF	8MIX 8MFA	3/4"-16 UNF 3/4"-16 UNF	8MB 8MBX
19.1								
20.0					M20 x 1.5 M20 x 1.5	12MDH 13MFG		
20.5								
20.8					1/2"-14 BSP	8MBSPP	1/2"-14 BSP	8MBFF
20.9								
21.5	1/2"-14 BSP	8MBSPT						
21.6					1/2"-14 NPTF	8MP		
22.0					M22 x 1.5 M22 x 1.5	14MDH 15MDL	13/16"-16 UN	8MFFOR
22.1			7/8"-14 UNF 7/8"-14 UNF	10MJ 10MS	7/8"-14 UNF	10MFA	7/8"-14 UNF 7/8"-14 UNF	10MB 10MBX
22.5								
22.8					5/8"-14 BSP	10MBSPP		
23.4	5/8"-14 BSP	10MBSPT						
23.6								
24.0					M24 x 1.5 M24 x 1.5	16MDH 17MFG		
24.4								
24.5								
25.0								
25.2								
25.3							1"-14 UNS	10MFFOR
25.4								

						
1/4"-18 NPSM	4FPX	7/16"-20 UNF 7/16"-20 UNF	4FJX 4FSX			9.1 9.9 10.3 10.5 11.0 11.5 11.7 11.9 12.0 12.5 12.9 13.0 13.6 13.9 14.0 14.1 14.5 15.2 15.5 15.7 16.0 16.5 17.1 17.3 17.5 18.0 18.5 18.9 19.1 20.0 20.5 20.8 20.9 21.5 21.6 22.0 22.1 22.5 22.8 23.4 23.6 24.0 24.4 24.5 25.0 25.2 25.3 25.4
M12 x 1.5 M12 x 1.5	6FDLORX 6FDLX	1/2"-20 UNF 1/2"-20 UNF	5FJX 5FSX			
1/4"-19 BSP 3/8"-18 NPSM	4FBSPORX 6FPX	1/4"-19 BSP	4FJISX			
M14 x 1.5 M14 x 1.5 M14 x 1.5	8FDLX 6FDHORX 8FDLORX	M14 x 1.5 9/16"-18 UNF	4FKX 6FJX	9/16"-18 UNF	4FFORX	
M16 x 1.5 M16 x 1.5 M16 x 1.5 M16 x 1.5	10FDLORX 8FDHORX 8FDHX 10FDLX					
3/8"-19 BSP 1/2"-14 NPSM	6FBSPORX 8FPX	3/8"-19 BSP 5/8"-18 UNF	6FJISX 6FSX	3/8"-19 BSP 11/16"-16 UN	6FBFFX 6FFORX	
M18 x 1.5 M18 x 1.5 M18 x 1.5 M18 x 1.5	10FDHORX 12FDLORX 10FDHX 12FDLX	M18 x 1.5	6FKX			
		3/4"-16 UNF 3/4"-16 UNF	8FSX 8FJX			
M20 x 1.5 M20 x 1.5 M20 x 1.5 M20 x 1.5	12FDHORX 14FDLORX 12FDHX 13FFGX	1/2"-14 BSP	8FJISX	1/2"-14 BSP	8FBFFX	
1/2"-14 NPSM	12FPX			13/16"-16 UN	8FFORX	
M22 x 1.5 M22 x 1.5 M22 x 1.5 M22 x 1.5	14FDHORX 15FDLORX 14FDHX 15FDLX	7/8"-14 UNF M22 x 1.5 7/8"-14 UNF	10FJX 8FKX 10FSX			
5/8"-14 BSP	10FBSPORX			5/8"-14 BSP	10FBFFX	
M24 x 1.5 M24 x 1.5 M24 x 1.5	17FFGX 16FDHORX 16FDHX	M24 x 1.5	10FKX			
				1"-14 UNS	10FFORX	
3/4"-14 BSP M26 x 1.5 M26 x 1.5	12FBSPORX 18FDLORX 18FDLX	3/4"-14 BSP	12FJISX	3/4"-14 BSP	12FBFFX	
		1.1/16"-12 UN 1.1/16"-14 UNS	12FJX 12FSX			
M27 x 1.5	20RU27A					

SELECTING THE CORRECT COUPLING

ENGINEERING AND TECHNICAL DATA

								
26.0				M26 x 1.5	18MDL			
26.3				3/4"-14 BSP	12MBSPP			
26.9		1.1/16"-12 UN 1.1/16"-14 UNS	12MJ 12 MS	1.1/16"-12 UN 3/4"-14 NPTF	12MFA 12MP	1.1/16"-12 UN 1.1/16"-12 UN	12MB 12MBX	
27.0	3/4"-14 BSP	12MBSPT						
28.0								
28.2								
28.5								
30.0			1.3/16"-12 UN	14MJ	M30 x 1.5 M30 x 2.0 M30 x 2.0	21MFG 20MDH 22MDL	1.3/16"-12 UN 1.3/16"-12 UN	12MFFOR 14MB
30.2								
30.6								
30.7								
31.3								
31.5								
31.8								
33.1					1"-11 BSP	16MBSPP		
33.2			1.5/16"-12 UN	16MJ	1.5/16"-12 UN	16MFA	1.5/16"-12 UN	16MB
33.7					1"-11.5 NPTF	16MP		
33.9	1"-11 BSP	16MBSPT						
34.0								
34.2								
34.4								
34.5								
36.0					M36 x 1.5 M36 x 2.0 M36 x 2.0	27MFG 25MDH 28MDL		
36.3							1.7/16"-12 UN	16MFFOR
38.1								
39.2								
39.3								
40.5								
40.7								
41.2			1.5/8"-12 UN	20MJ			1.5/8"-12 UN	20MB
41.3								
41.4								
41.8					1.1/4"-11 BSP	20MBSPP		
42.0					M42 x 2.0	30MDH		
42.5					1.1/4"-11.5 NPTF	20MP		
42.6							1.11/16"-12 UN	20MFFOR
43.0								
43.5								
44.5								
45.0					M45 x 1.5 M45 x 2.0	34MFG 35MDL		
45.2								
45.5								
47.5			1.7/8"-12 UN	24MJ				
47.6								
47.7					1.1/2"-11 BSP	24MBSPP/24MU		
48.6					1.1/2"-11.5 NPTF	24MP/24MB		
48.7								
50.0								
50.8								
52.0					M52 x 1.5 M52 x 2.0 M52 x 2.0	42MFG 38MDH 42MZ52B		
54.0								
59.5					2"-11 BSP	32MU		
60.3								
60.5	2"-11 BSP	32MT						
60.7					2"-11.5 NPTF	32MP/32MB		
61.4								
63.3			2.1/2"-12 UN	32MJ				
63.5								
71.4								
79.4								
79.5								

									26.0
									26.3
									26.9
									27.0
	M30 x 2.0 M30 x 2.0 M30 x 2.0 M30 x 2.0	20FDHORX 22FDLORX 20FDHX 22FDLX			13/16"-16 UN	12FFORX			28.0
	M30 x 1.5	21FFGX	1.3/16"-12 UN M30 x 1.5	14FJX 12FKX					28.2
									28.5
									30.0
	1"-11 BSP 1"-11.5 NPSM	16FBSPORX 16FPX	1"-11 BSP	16FJISX	1"-11 BSP	16FBFFX	1/2" - CODE 61	8FL	30.2
			1.5/16"-12 UN M33 x 1.5	16FJX 16FKX					30.6
									30.7
							1/2" - CODE 62	8FLH	31.3
									31.5
									31.8
									33.1
									33.2
									33.7
									33.9
	M36 x 2.0 M36 x 2.0 M36 x 2.0	25FDHORX 28FDLORX 28FDLX							34.0
	M36 x 1.5	27FFGX	M36 x 1.5	20FKX	1.7/16"-12 UN	16FFORX	5/8" - KOMATSU	10FLK	34.2
									34.4
									34.5
									36.0
									36.3
							3/4" - CODE 61	12FL	38.1
	1 1/4"-11 BSP	20FBSPORX	1.5/8"-12 UN	20FJX					39.2
									39.3
									40.5
					1.11/16"-12 UN	20FFORX			40.7
									41.2
							3/4" - CODE 62	12FLH	41.3
							3/4" - CAT	12FLC	41.4
									41.8
	M42 x 2.0	30FDHORX							42.0
									42.5
									42.6
	M45 x 2.0 M45 x 1.5	35FDLORX 34FFGX							43.0
									43.5
							1" - CODE 61	16FL	44.5
									45.0
	1.1/2" -11 BSP	24FBSPORX	1.7/8"-12 UN	24FJX/24NJ					45.2
									45.5
									47.5
							1" - CODE 62 1" - CAT	16FLH 16FLC	47.6
									47.7
									48.6
									48.7
	M52 x 2.0 M52 x 1.5 M52 x 1.5	38FDHORX 42RO52A 42FFGX			2"-12 UN	24FFORX/24FF			50.0
							1.1/4" - CODE 61	20FL	50.8
									52.0
							1.1/4" - CAT 1.1/4" - CAT	20FLC 20FLH	54.0
	2"-11 BSP	32NU					1.1/2" - CODE 61	24FL/24PA	59.5
									60.3
									60.5
									60.7
			2.1/2"-12 UN	32FJX/32NJ					61.4
									63.3
							1.1/2" - CAT 1.1/2" - CODE 62	24FLC 24FLH	63.5
							2" - CODE 61	32FL/32PA	71.4
							2" - CODE 62	32FLH	79.4
							2" - CAT	32FLC	79.5

HOSE ASSEMBLY SELECTION AND INSTALLATION

ENGINEERING AND TECHNICAL DATA

CALCULATING THE HOSE ASSEMBLY LENGTH

Hose assemblies are made according to overall length i.e. cone face to cone face, or where elbow couplings are used, to the centre line of the cone face.

When determining the length of hose assemblies, provide sufficient length to prevent bending strain from localising at the back of the coupling. In the figure below dimension "B" allows for a strain section of hose beyond the coupling to prevent concentration of bending strain. "T" designates the amount of travel. "A" indicates the smallest diameter to which the hose should be bent (2x minimum bend radius).

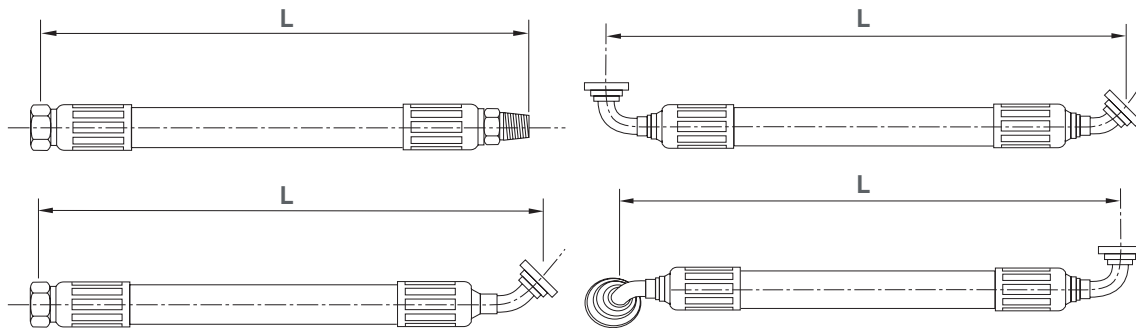

T (Actuation travel)

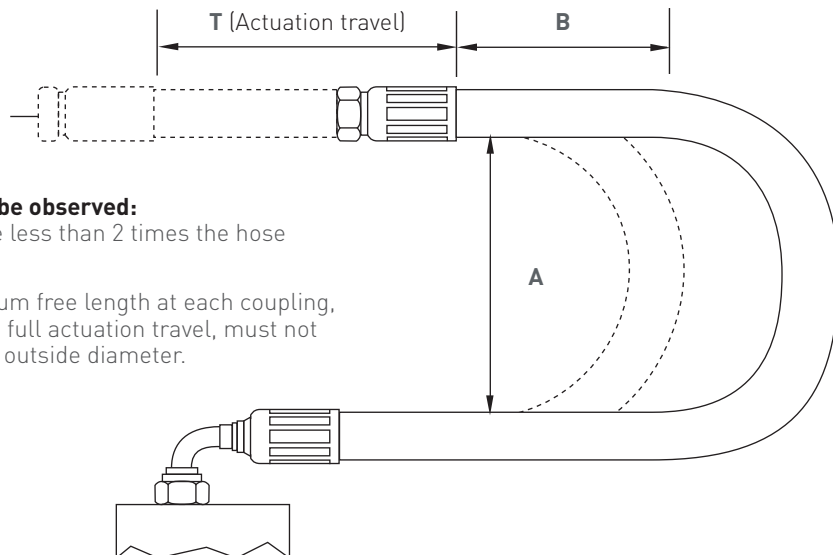

2 critical dimensions must be observed:

1. Dimension 'A' must not be less than 2 times the hose minimum bend radius.
2. Dimension 'B', the minimum free length at each coupling, taking into account 'T' the full actuation travel, must not be less than 2 times hose outside diameter.

CAUTION

When cutting hose, always wear safety glasses and avoid loose fitting clothing. Ear protection is also strongly recommended. Ensure adequate ventilation.

Fitting orientation

Fitting orientation is necessary when a hose assembly requires two angled couplings that are not in line when viewed from one end of a hose. Fittings must be orientated to each other to ensure proper installation with minimal stress on the hose from twisting.

Fitting orientation is measured from the centerline of the first coupling held in a vertical position and looking at the assembly from the second end by measuring in a clockwise direction.

Orientation angle tolerance should be ± 3 degrees for assemblies equal or less than 600 mm and ± 5 degrees for assembly lengths over 600 mm.

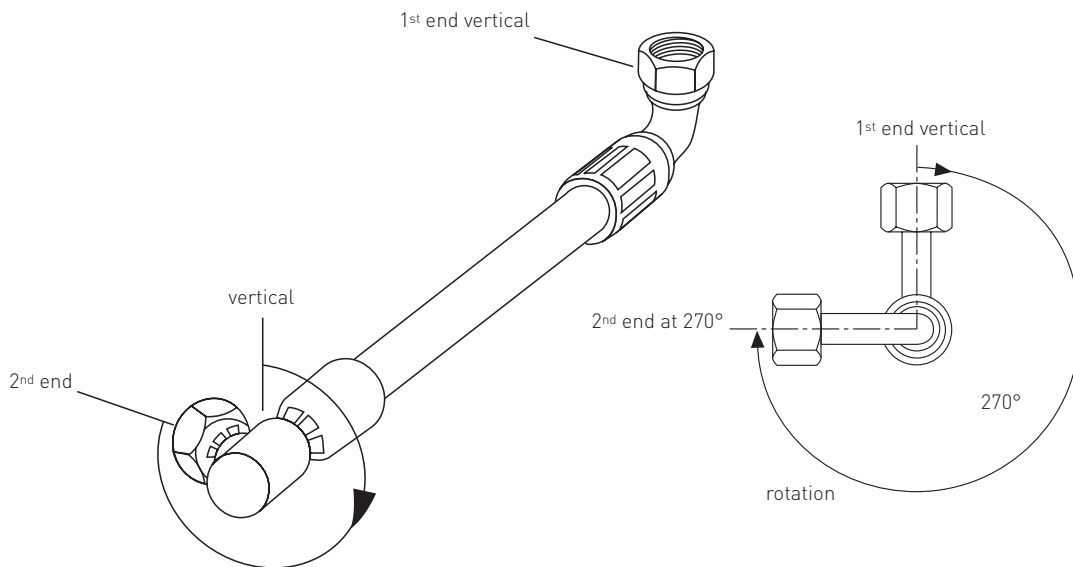

HOSE ASSEMBLY ROUTING TIPS

Proper hose installation is essential for satisfactory performance. As we have seen, if hose length is excessive, the appearance of the installation will be unsatisfactory and unnecessary cost of equipment will be involved. If hose assemblies are too short to permit adequate flexing and changes in length due to expansion or contraction, hose service life will be reduced.

The following diagrams show proper hose installations which provide maximum performance and cost savings. Consider these examples in determining the length of a specific assembly.

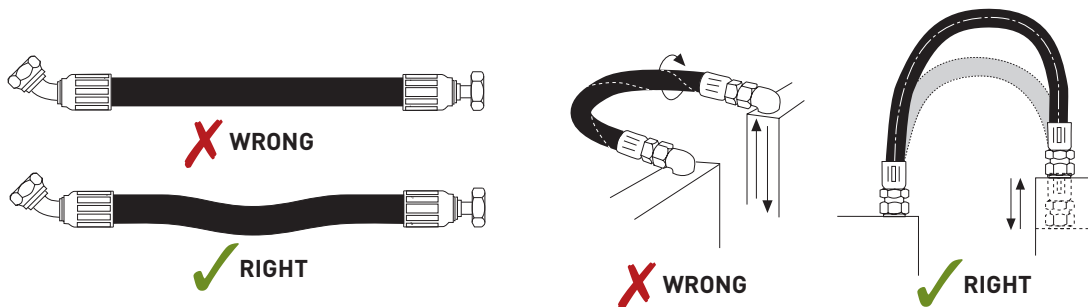

When hose installation is straight, allow enough slack in hose line to provide for length changes which will occur when pressure is applied.

Prevent twisting and distortion by bending hose in same plane as the motion of the boss to which hose is connected.

HOSE ASSEMBLY SELECTION AND INSTALLATION

ENGINEERING AND TECHNICAL DATA

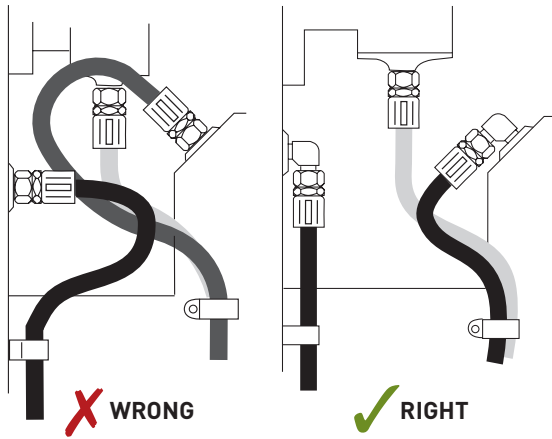

Route hose directly by using 45° and/or 90° adaptors and fittings. Avoid excessive hose length to improve appearance.

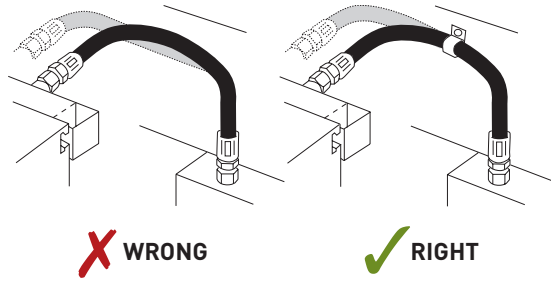

Avoid twisting of hose lines bent in two planes by clamping hose at change of plane.

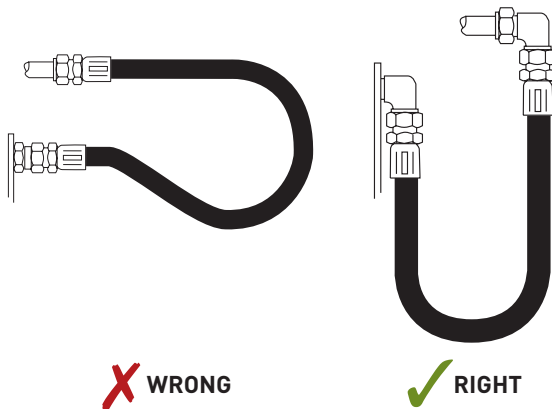

When radius is below the required minimum, use an angle adaptor to avoid sharp bends.

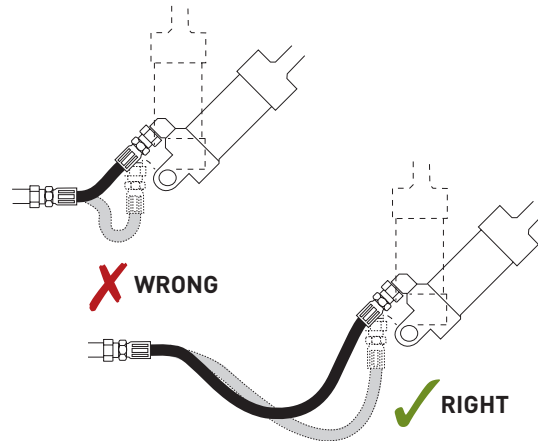

Adequate hose length is necessary to distribute movement on flexing applications and to avoid abrasion.

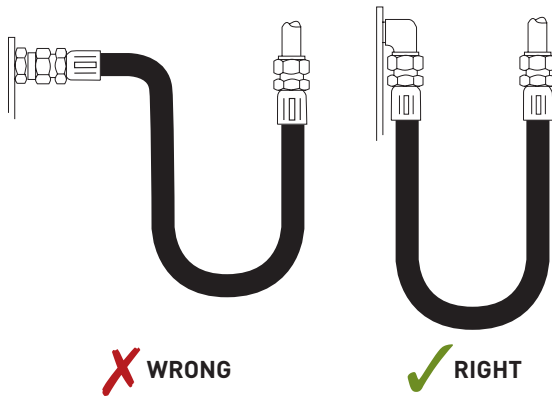

Use proper angle adaptors to avoid sharp twist or bend in hose.

NO PRESSURE

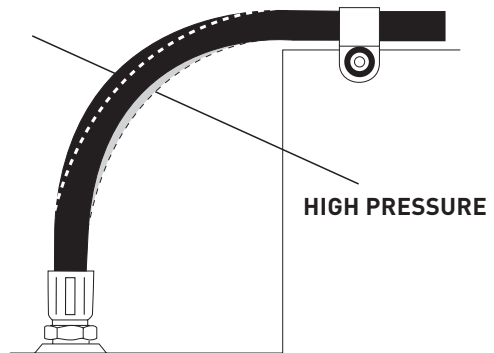

To allow for length changes when hose is pressurised, do not clamp at bends so that curves will absorb changes. Do not clamp high and low pressure lines together.

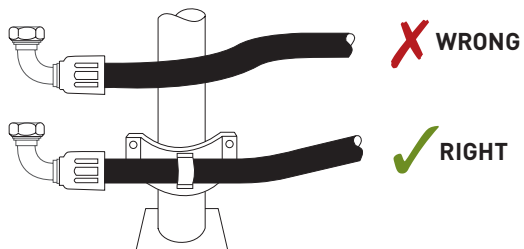

High ambient temperatures shorten hose life. Make sure hose is kept away from hot parts. If this is not possible, insulate the hose.

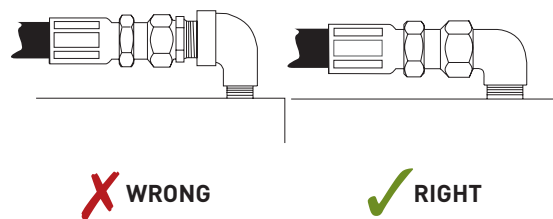

Reduce number of pipe thread joints by using proper hydraulic adaptors instead of pipe fittings.

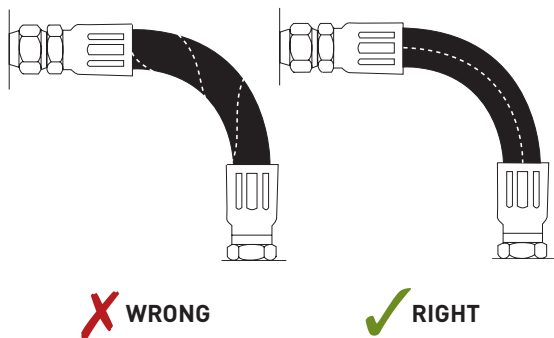

When installing a hose, make sure it is not twisted. Pressure applied to a twisted hose can result in hose failure or loosening of connections.

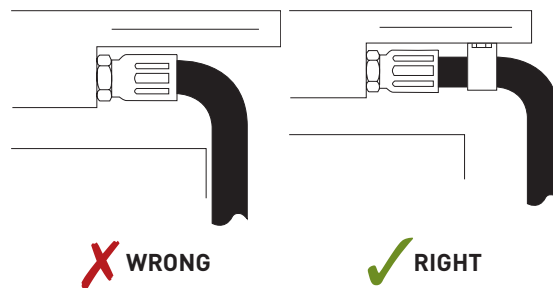

Run hose in the installation so that it avoids rubbing and abrasion. Often, clamps are required to support long hose runs or to keep hose away from moving parts. Use clamps of the correct size. Too large a clamp allows hose to move inside the clamp and causes abrasion.

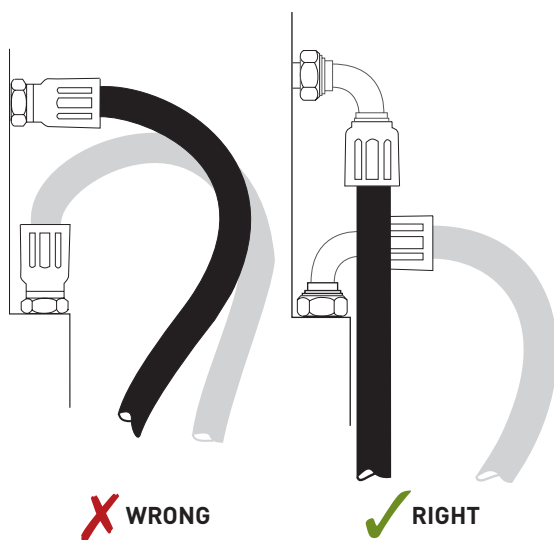

Elbows and adaptors should be used to relieve strain on the assembly, and to provide neater installations which will be more accessible for inspection and maintenance.

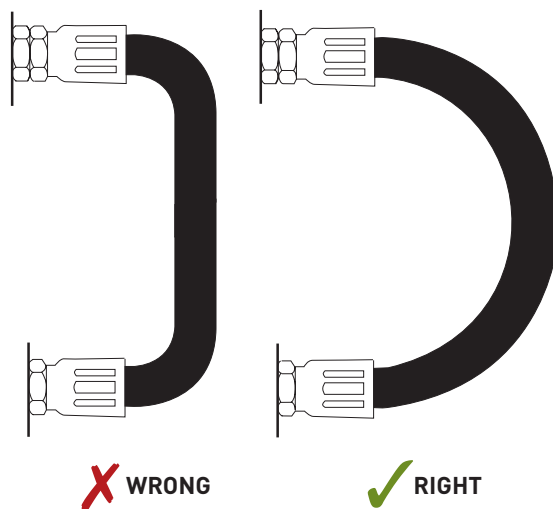



To avoid hose collapse and flow restriction, keep hose bend radii as large as possible. Refer to hose specification tables for minimum bend radii.

HOSE ASSEMBLY SELECTION AND INSTALLATION



ENGINEERING AND TECHNICAL DATA

RECOMMENDED COUPLING AND ADAPTOR INSTALLATION TORQUE IN NM



SAE 37° & 45° MJ, FJX, MIX, FSX

				
-size	DN		Min.	Max.
-4	6	7/16" - 20	13	15
-5	8	1/2" - 20	18	20
-6	10	9/16" - 18	23	26
-8	12	3/4" - 16	47	52
-10	16	7/8" - 14	69	76
-12	20	1.1/16" - 12	96	106
-16	25	1.5/16" - 12	127	141
-20	32	1.5/8" - 12	169	188
-24	38	1.7/8" - 12	212	235
-32	50	2.1/2" - 12	296	329



BSP 60° CONE MBSPT, MBSPP, FBSPORX

				
-size	DN		Min.	Max.
-4	6	1/4" - 19	15	18
-6	10	3/8" - 19	26	31
-8	12	1/2" - 14	41	49
-10	16	5/8" - 14	50	60
-12	20	3/4" - 14	70	80
-16	25	1" - 11	105	125
-20	32	1.1/4" - 11	170	190
-24	38	1.1/2" - 11	225	250
-32	50	2" - 11	360	420



FLAT-FACED 'O' RING SEAL FFORX

				
-size	DN		Min.	Max.
-4	6	9/16" - 18	14	16
-6	10	11/16" - 16	24	27
-8	12	13/16" - 16	43	54
-10	16	1" - 14	60	75
-12	20	1.3/16" - 12	90	110
-16	25	1.7/16" - 12	125	140
-20	32	1.11/16" - 12	170	190
-24	38	2" - 12	200	245



DIN SERIES MDL, MDH, MSP, FDLX, FDHX, FDLORX, FDHORX

				
-size	DN		Min.	Max.
6	-	M12 x 1.5	13	17
8	-	M14 x 1.5	23	28
10	8	M16 x 1.5	33	38
12	10	M18 x 1.5	38	42
-	12	M20 x 1.5	48	52
15	14	M22 x 1.5	52	58
-	16	M24 x 1.5	62	68
18	-	M26 x 1.5	80	90
22	20	M30 x 2	105	115
28	25	M36 x 2	125	135
-	30	M42 x 2	200	220
35	-	M45 x 2	205	225
42	38	M52 x 2	290	310

O-RING BOSS MB, MBX

						
-size	DN		L series		S series.	
			Min.	Max.	Min.	Max.
-4	6	7/16" - 20	18	20	20	22
-5	8	1/2" - 20	20	25	24	27
-6	10	9/16" - 18	25	30	33	35
-8	12	3/4" - 16	45	50	70	75
-10	16	7/8" - 14	60	70	100	110
-12	20	1.1/16" - 12	95	105	170	180
-14	22	1.3/16" - 12	-	-	215	240
-16	25	1.5/16" - 12	150	170	270	300
-20	32	1.5/8" - 12	180	200	285	315
-24	38	1.7/8" - 12	210	230	370	410

SAE FLANGES FL, FLH

					
-size	DN	L series		S series.	
		Min.	Max.	Min.	Max.
-8	12	20	25	20	25
-12	20	28	40	34	45
-16	25	37	48	56	68
-20	32	48	62	85	102
-24	38	62	79	158	181
-32	50	75	90	271	294

SELECTING THE CORRECT TUBE FITTING

GATES-EMB DS RING - CHARACTERISTICS

The Gates-EMB DS ring is the product of extensive research and further development of the well-known EMB cutting ring. Due to the design of the cutting ring geometry, the edges do not cut simultaneously, but one after the other, although the cutting diameter of each cutting edge is exactly equal.

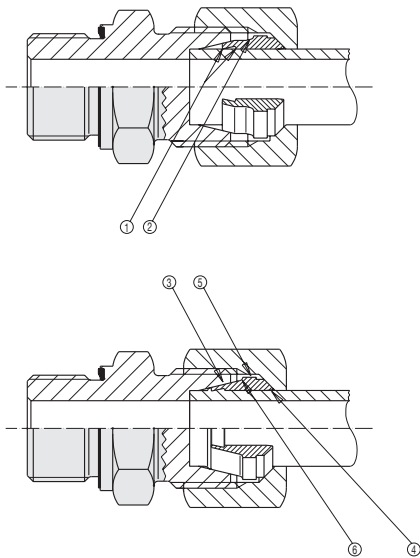

- ① Consequently, the cutting effect is improved and this results in a much greater steadiness during excision at the end of the installation with only slightly more effort.
- ② The DS ring has a limiting surface that signals the end of the installation owing to its location within the body cone. And thereby a force increase is perceptible.
- ③ As both cuttings, as well as the central section, are supported by the cone body, the force is favourably distributed within the cone and this ensures a secure holding function.
- ④ Due to the conical design of the inside end, and the distribution of forces across the cone of the body, the alternating bending stresses that occur are distributed throughout the length of the ring and damped by the cone body and the nut.
- ⑤ The conical surface opposite the cutting edges is smooth, which reduces friction during the assembly, providing a stronger grip. Besides higher stability, the reinforced end of the DS ring reduces friction and takes the pressure off the base of the nut. The required reduction of the cross-section optimises the radial stability and keeps the tube secure.
- ⑥ The stop surface clearly limits over-winding by the bearing at the stud's front surface.

GATES-EMB DSW RING - CHARACTERISTICS

According to current expectations, the connecting points of pipes, installations, etc., should be fitted with soft sealing elements, preferably elastomer materials in order to satisfy the demand for effective sealing. This is particularly important in connections with long-term seals that are subject to extreme stresses in order to protect the environment and resources.

The DSW ring complements the proven range of Gates-EMB pipe connections by providing a soft, elastomer-type seal on the pipe side. The ring can be used in standard screw connecting systems with a 24° cone in conformity with DIN 3861, form W, in conjunction with the union nut DIN 3870, form A, or screw connections according to ISO 8434-1. If necessary, the elastomeric sealing ring can be exchanged easily.

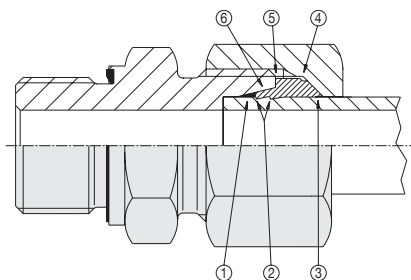

- ① The important primary sealing function is handled by a soft elastomer sealing ring that is integrated in the metal ring for simple installation. It is profiled to match the sealing space, thereby guaranteeing positive fine sealing.
- ② The hold function is performed by a metal ring. This has a special cutting edge shape and a rearward receding cutting edge.
- ③ In order to avoid the unfavourable notch effect on the pipe, the inner contour tapers off into a shallow shoulder end.
- ④ The thick shoulder area, which reduces the surface pressure exerted by the union nut, is followed by a cross-section reduction which contributes to secure pipe clamping.
- ⑤ The wide contact area, which is also the result of the maximum reinforcement of the middle section, ensures that the screw tightening force can be genuinely limited.
- ⑥ The profiled case surface rests against the body cone where it forms an additional metallic seal.

SELECTING THE CORRECT TUBE FITTING

ENGINEERING AND TECHNICAL DATA

CUTTING RING FITTINGS - ASSEMBLY WITH VM ADAPTOR

The sequential assembly of cutting ring fittings with subsequent final assembly.

This process is turning angle controlled.

For assemblies using both steel and stainless steel pipes as well as adjustable shaft fittings and pipe-support tubes, the pre-assembly is only to be carried out using the adaptor VM or using other pre-assembly appliances (see chapter "The World of Assembly Machinery").

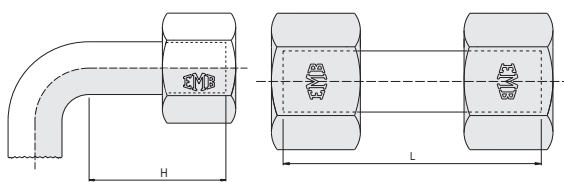

Minimum length (H) of straight tube end for tube bends.

Minimum length (L) for short sections of pipe.

Series	LL				L										S									
tube OD mm	4	5	6	8	6	8	10	12	15	18	22	28	35	42	6	8	10	12	14	16	20	25	30	38
H min	24	25	25	26	31	31	33	33	36	38	42	42	48	48	35	35	37	37	43	43	50	54	58	65
L min	30	32	32	33	39	39	42	42	45	48	53	53	60	60	44	44	47	47	54	54	63	68	73	82

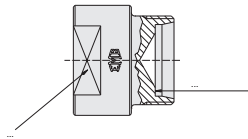

The galvanised Gates-EMB cutting-ring fitting is coated with a clear sliding agent, reducing friction and eliminating the need to additionally oil the components. In order to ensure positive assembly, Gates-EMB fittings should always be pre-assembled in an oiled pre-assembly adaptor.

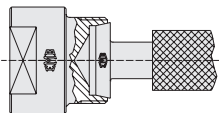

The dimensional stability of the cones will be guaranteed by means of continually checking with a cone gauge.

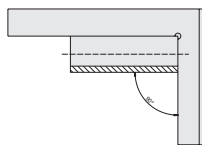

Pipes have to be sawn off rectangularly. Do not use a pipe cutter!

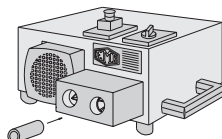

Clean the pipe inside and outside.

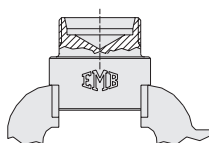

Clamp the pre-mounting socket in a vice, having previously selected the appropriate series and pipe dimensions.

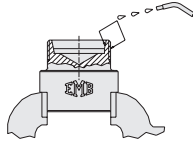

Oil pre-mounting socket - do not grease. When using non-rusting materials it is necessary to lubricate the cutting ring and the nut, as well as the VM, by using a special lubricating agent. For this purpose we recommend Gates-EMB lubricating paste. Do not use commercially available lubricating oils!

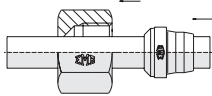

Move screwing components over the pipe end as illustrated.

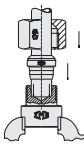

Position pipe in the pre-mounting socket and press firmly against the stop in the inner cone.

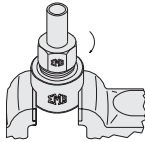

Tighten the coupling nut until the pipe no longer turns in the assembly. The cutting ring then locks on to the pipe.

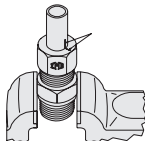

A mark on the nut indicates the turning direction.

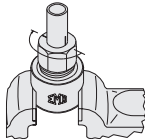

Tighten the coupling nut by half a turn. The cutting ring will uniformly cut into the pipe.

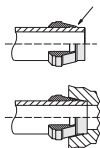

After pre-assembly, check whether a visible flare is present before the first cut. Use a partially slotted series connecting piece for this purpose. The contact face of the pre-assembled pipe must rest against the pipe stop of the screw union connection.

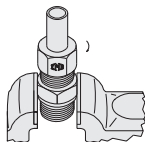

Insert the pre-assembled tube into the assembly socket and turn it approximately 1/2 turn, beyond the point where the torque rise makes itself felt.

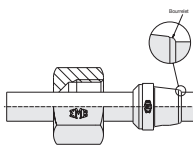

After the connection has been tightened, release it again. Check whether the collar bulge fills the space in front of the cutting edge. The ring can rotate but cannot be moved on its axis.



Each time the connection is disconnected, the union nut must be retightened firmly(similar to final assembly). Use a spanner to counter the screw connection!

SELECTING THE CORRECT TUBE FITTING

ENGINEERING AND TECHNICAL DATA

CUTTING RING COUPLINGS - ASSEMBLY

Assembly in the screw socket and direct assembly for repair purposes

Pipes made of non-rusting steel, pipe-supports, tube fittings and adjustable shaft screw fittings must be assembled using the pre-assembly adaptor (VM) or using other assembly appliances (see chapter "The World of Assembly Machinery").

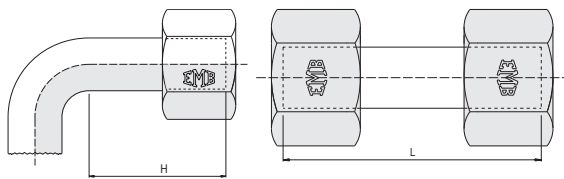

Minimum length (H) of straight tube end for tube bends.

Minimum length (L) for short sections of pipe.

Series	LL				L										S									
tube OD mm	4	5	6	8	6	8	10	12	15	18	22	28	35	42	6	8	10	12	14	16	20	25	30	38
H min	24	25	25	26	31	31	33	33	36	38	42	42	48	48	35	35	37	37	43	43	50	54	58	65
L min	30	32	32	33	39	39	42	42	45	48	53	53	60	60	44	44	47	47	54	54	63	68	73	82

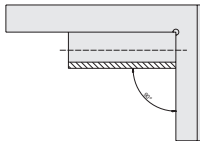

Pipes have to be sawn off rectangularly. Do not use a pipe cutter!

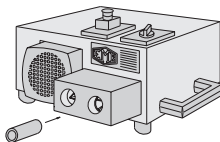

Clean the pipe inside and outside.

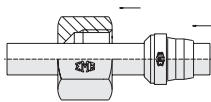

Move screwing components over the pipe end as illustrated.

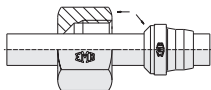

The collar of the cutting ring must face the coupling nut - otherwise a faulty assembly will be the result.

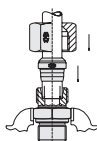

Position the pipe in the pre-mounting socket and press firmly against the stop in the inner cone.

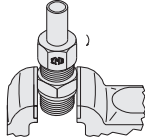

Tighten the coupling nut until the pipe no longer turns in the assembly. The cutting ring then locks on to the pipe.

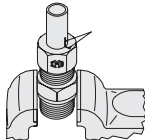

A mark on the nut indicates the turning direction.

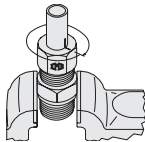

Tighten the coupling nut by one turn. The cutting ring will evenly cut into the pipe and clearly raise and remove material in front of its cutting edge.

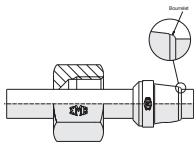

After the connection has been tightened, release it again. Check whether the collar bulge fills the space in front of the cutting edge. The ring can rotate but cannot be moved on its axis.



Each time the fitting is disassembled the nut must be retightened firmly (similar to final assembly). Use a spanner to counter the screw connection!

When using a series-type screw socket, make sure that every pipe end is repositioned within the same inner cone in which the pre-mounting process takes place.

SELECTING THE CORRECT TUBE FITTING

ENGINEERING AND TECHNICAL DATA

ADJUSTABLE COUPLINGS WITH LOCKNUT - ASSEMBLY

Couplings without support ring for stud ports
ISO 6149 or UN/UNF.

Couplings with support ring for stud ports
Whitworth or metric parallel thread with wide
or small spot face.

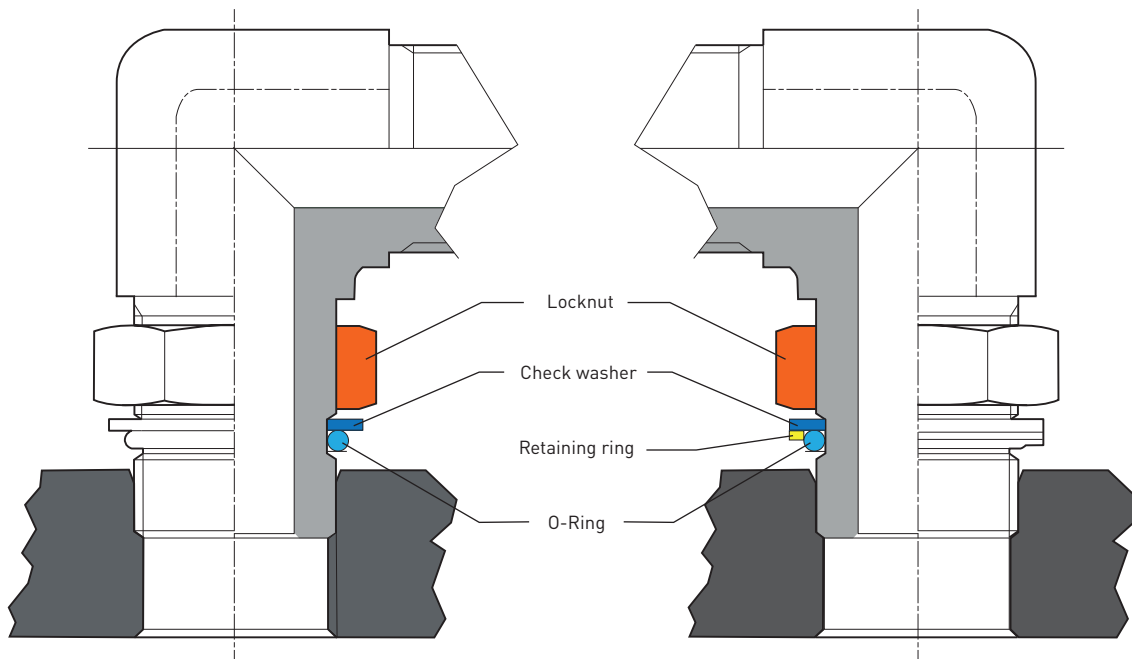

1. Unlock nut as far as possible, check O-ring, washer and retaining ring. These should be in their proper position at the locknut. Oil the O-ring.
2. Screw fitting by hand into the thread port until the washer or retaining ring contact the face of the port.
3. Push fitting in the required position and tighten locknut.
4. Hold fitting in wanted position and tighten locknut.

GATES-EMB CUTTING RING TYPE PIPE SCREW JOINTS

Standardisation

Deriving from different standards, pipe screw joints and accessories have been improved by constant developments to achieve the present level of quality. This level is in accordance with the standards DIN 2353/ISO 8434-1 and -4. The majority of Gates-EMB parts and patterns exceed the standard pressure ratings.

Gates-EMB has more than 60 years of experience in manufacturing precision parts, thereby enabling us – together with the certified quality assurance – to ensure the utmost reliability of the products.

Performance and operational reliability of the Gates-EMB fitting can only be guaranteed if both Gates-EMB components are used and Gates-EMB assembly instructions are adhered. Further technical development reserved.

Materials

The Gates-EMB pipe screw joints included in this catalogue are normally manufactured from drawn or forged steel:

Gates-EMB pipe screw joints of steel.

Gates-EMB pipe screw joints of stainless steels – 6CrNiMoTi17122, 1.4571.

Compressive strength and thermal endurance

The pressure specifications given in our catalogue relate to steel fittings with a static load at a temperature of up to + 120°C and refer to the rated pressure PN (nominal pressure) according to DIN EN 764-1. PN has a safety factor of 4 [DIN 3859].

Unless otherwise indicated, the pressures mentioned in brackets represent the EMB maximum bursting pressure.

PB is the overpressure of the operating pressure according to DIN EN 764-1. Unless otherwise indicated, the safety factor for PB is 2,5.

Pressure range

Series	LL			L										S									
	4	6	8	6	8	10	12	15	18	22	28	35	42	6	8	10	12	14	16	20	25	30	38
K1	100			500				400			250			800			630			400			
K2	100				250				160		100				630					400			250
K3*	100					315					160				630					400			315

* Pressure drop to be considered.

K1 - Steel // DS-Ring, DSW-Ring.

K2 - Stainless Steel // S-Ring.

K3 - Stainless Steel // DS-Ring, DSW-Ring.

Working temperature for fittings

Steel: -40°C up to +120°C [DIN 3859].

Stainless steel: -60°C up to +400°C [DIN EN 10088-3].

Consider below information "Reduction of pressure".

SELECTING THE CORRECT TUBE FITTING

ENGINEERING AND TECHNICAL DATA

Working temperature for sealings

NBR (e.g. Perbunan*): -35°C up to +100°C.

FKM (e.g. Viton**): -25°C up to +200°C.

PTFE (e.g. Teflon**): -60°C up to +200°C.

The temperatures are recommendations only. These can be influenced by the operating medium. To define the use of different materials (components or joints), take the smallest respective temperatures limits as a starting point.

Temperature dependent pressure rating reduction

A reduction of pressure is necessary when operating at various temperatures.

Material fitting	Temperature range	Reduction of pressure
Steel	- 40°C up to + 120°C	no
1,4571	- 60°C up to + 20°C	no
1,4571	+ 50°C	4 %
1,4571	+ 100°C	11 %
1,4571	+ 200°C	20 %
1,4571	+ 300°C	29 %
1,4571	+ 400°C	33 %

For other tubes and fitting materials, the tubes have to be tested separately on both the approved temperature range and the necessary reduction of pressure.

When using male stud couplings, additional pressure reductions may apply. This is caused by both the counter material which the part is screwed into and the sealing material.

To make use of the maximum operating pressure, we recommend male stud couplings with WD sealing (soft seal). Depending on the counter material, an alternative sealing material may be necessary.

Further different circumstances should be considered. Approved pressures, security factors, temperatures as well as standards, instructions or registrations may influence the pressure calculation.

Rated pressure (PN) and operating pressure (PB) are the maximum permissible working pressures, including any pressure peaks. The pressure has to be adjusted in accordance to the temperature variations. The pressure and security details apply only when using original Gates-EMB parts as well as following the Gates-EMB assembly instructions. Perfect clamping of the tube system is important in order to reduce vibration and to prevent subsequent damage.

Surface

To provide durable surface protection, Gates-EMB cutting ring type pipe screw joints are coated with NanoProtect™. Other coatings such as Zink-Nickel protection can be delivered upon request.

Storage

For parts with soft sealing, please follow instructions and pay attention to comments according to DIN 7716.

* Registered trademark of BAYER AG.

** Registered trademark of DU PONT.

SELECTING THE CORRECT TUBE FITTING

ENGINEERING AND TECHNICAL DATA

STUD THREADS AND PORTS FOR PIPE COUPLINGS

BSP parallel DIN-ISO 228

BSP taper DIN 3858

Metric parallel DIN 13

Metric taper DIN 158

Soft sealing and O-ring sealing NBR (Perbunan*); FKM upon request (Viton**).

Stud thread form A	Stud thread form B	Stud thread form E	Stud thread form SBE	Stud thread form C
DIN 3852 Part 1+2	DIN 3852 Part 1+2	DIN 3852 Part 11	EMB	DIN 3852 Part 1+2
Sealing by sealing ring DIN 7603	Sealing by sealing shoulder	Sealing by soft ring	Sealing by EDE ring or DKA	Sealing by conical thread

Port form X	Port form X	Port form X	Port form X	Port form Z
DIN 3852 Part 1+2 for parallel stud threads	DIN 3852 Part 1+2 for parallel stud threads	DIN 3852 Part 1+2 for parallel stud threads	DIN 3852 Part 1+2 for parallel stud threads	DIN 3852 Part 1+2 for conical stud threads

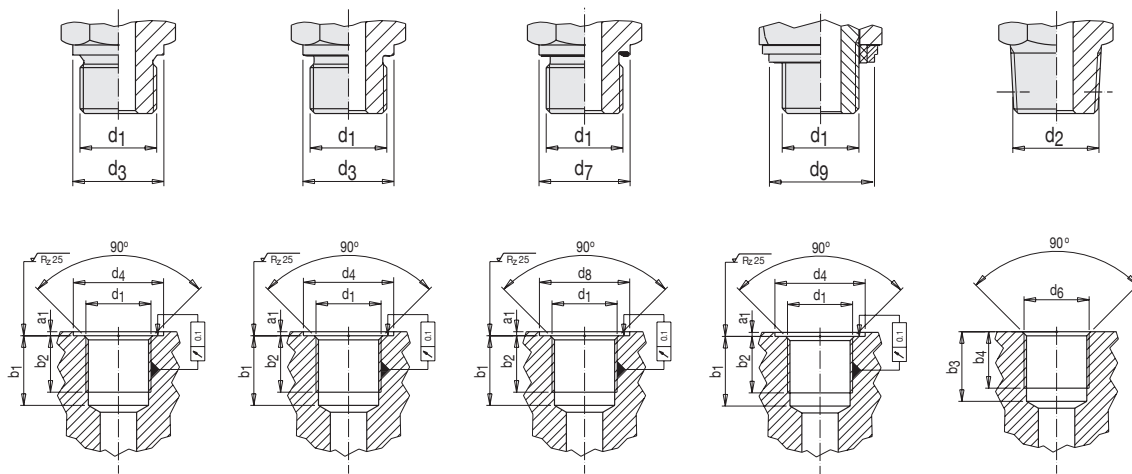

* Registered trademark of BAYER AG.

** Registered trademark of DU PONT.

Pipe OD mm	Series	BSP												Metric													
		d ₁ **	d ₄	d ₃	d ₈	d ₇	d ₉	a ₁	b ₁	b ₂	d ₂	d ₆	b ₃	b ₄	d ₁	d ₄	d ₃	d ₈	d ₇	d ₉	a ₁	b ₁	b ₂	d ₂	b ₃	b ₄	
4	L1	G 1/8"A	15	14				1	13	8	R 1/8" taper	G 1/8"	9.5	5.5											M 8x1 taper	10	5.5
																									M 8x1 taper	10	5.5
		G 1/8"A	15	14				1	13	8	R 1/8" taper	G 1/8"	9.5	5.5											M 10x1 taper	10	5.5
		G 1/8"A	15	14				1	13	8	R 1/8" taper	G 1/8"	9.5	5.5											M 10x1 taper	10	5.5
6	L	G 1/8"A	15	14	15	13.9	14.9	1	13	8	R 1/8" taper	G 1/8"	9.5	5.5	M 10x1	15	14	15	13.9	14.9	1	13.5	8	M 10x1 taper	10	5.5	
		G 1/4"A	19	18	20*	18.9*	18.9	1.5	18.5	12	R 1/4" taper	G 1/4"	13.5	8.5	M 12x1.5	18	17	18	16.9	16.9	1.5	18.5	12	M 12x1.5 taper	13.5	8.5	
		G 1/4"A	19	18	20*	18.9*	18.9	1.5	18.5	12	R 1/4" taper	G 1/4"	13.5	8.5	M 14x1.5	20	19	20	18.9	18.9	1.5	18.5	12	M 14x1.5 taper	13.5	8.5	
		G 3/8"A	23	22	23	21.9	21.9	2	18.5	12	R 3/8" taper	G 3/8"	13.5	8.5	M 16x1.5	22	21	23*	21.9*	21.9	1.5	18.5	12	M 16x1.5 taper	13.5	8.5	
		G 1/2"A	27	26	28*	26.9*	26.9	2.5	22	14	R 1/2" taper	G 1/2"	16.5	10.5	M 18x1.5	24	23	25*	23.9*	23.9	2	18.5	12	M 18x1.5 taper	13.5	8.5	
		G 1/2"A	27	26	28*	26.9*	26.9	2.5	22	14	R 1/2" taper	G 1/2"	16.5	10.5	M 22x1.5	28	27	28	26.9	26.9	2.5	20.5	14	M 22x1.5 taper	15.5	10.5	
		G 3/4"A	33	32	33	31.9	32.9	2.5	24	16	R 3/4" taper	G 3/4"	19	13	M 26x1.5	32	31	33*	31.9*	31.9	2.5	22.5	16				
		G 1"A	40	39	41*	39.9*	39.9	2.5	27	18	R 1" taper	G 1"	23	16	M 33x2	40	39	41*	39.9*	39.9	2.5	26	18				
		G 1 1/4"A	50	49	51*	49.9*	49.9	2.5	29	20	R 1 1/4" taper	G 1 1/4"	24	17	M 42x2	50	49	51*	49.9*	49.9	2.5	28	20				
		G 1 1/2"A	56	55	56	54.9	55.9	2.5	31	22	R 1 1/2" taper	G 1 1/2"	24	17	M 48x2	56	55	56	54.9	55.9	2.5	30	22				
6	S	G 1/4"A	19	18	20*	18.9*	18.9	1.5	18.5	12	R 1/4" taper	G 1/4"	13.5	8.5	M 12x1.5	18	17	18	16.9	16.9	1.5	18.5	12	M 12x1.5 taper	13.5	8.5	
		G 1/4"A	19	18	20*	18.9*	18.9	1.5	18.5	12	R 1/4" taper	G 1/4"	13.5	8.5	M 14x1.5	20	19	20	18.9	18.9	1.5	18.5	12	M 14x1.5 taper	13.5	8.5	
		G 3/8"A	23	22	23	21.9	21.9	2	18.5	12	R 3/8" taper	G 3/8"	13.5	8.5	M 16x1.5	22	21	23*	21.9*	21.9	1.5	18.5	12	M 16x1.5 taper	13.5	8.5	
		G 3/8"A	23	22	23	21.9	21.9	2	18.5	12	R 3/8" taper	G 3/8"	13.5	8.5	M 18x1.5	24	23	25*	23.9*	23.9	2	18.5	12	M 18x1.5 taper	13.5	8.5	
		G 1/2"A	27	26	28*	26.9	26.9	2.5	22	14	R 1/2" taper	G 1/2"	16.5	10.5	M 20x1.5	26	25	27*	25.9*	25.9	2	20.5	14	M 20x1.5 taper	15.5	10.5	
		G 1/2"A	27	26	28*	26.9*	26.9	2.5	22	14	R 1/2" taper	G 1/2"	16.5	10.5	M 22x1.5	28	27	28	26.9	26.9	2.5	20.5	14	M 22x1.5 taper	15.5	10.5	
		G 3/4"A	33	32	33	31.9	32.9	2.5	24	16					M 27x2	33	32	33	31.9	32.9	2.5	24	16				
		G 1"A	40	39	41*	39.9*	39.9	2.5	27	18					M 33x2	40	39	41*	39.9*	39.9	2.5	26	18				
		G 1 1/4"A	50	49	51*	49.9*	49.9	2.5	29	20					M 42x2	50	49	51*	49.9*	49.9	2.5	28	20				
		G 1 1/2"A	56	55	56	54.9	55.9	2.5	31	22					M 48x2	56	55	56	54.9	55.9	2.5	30	22				

* Deviating from DIN 3852.

** For female thread "A" does not apply.

SELECTING THE CORRECT TUBE FITTING

ENGINEERING AND TECHNICAL DATA

Metric parallel DIN ISO 6149-1/-2/-3
UNF / UN parallel ISO 11926-1/-2/-3
NPT taper ANSI / ASME B1.20.1-1983

O-ring sealing NBR (Perbunan*); FKM upon request (Viton**).

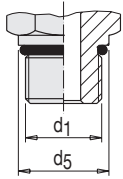

Stud
 DIN ISO 6149-2+3.
 Sealing by O-ring.

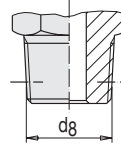

Stud thread NPT
 ANSI / ASME B1.20.1-1983.
 Sealing by conical thread.

Stud threads UNF and UN-2 A
 ISO 11926-2+3.
 Sealing by O-ring.

d1	d5	d2	d3	d4	a1	a2	b1	b2	α
UNF/UN	- 0.4	± 0.05		min.	max.	0.4	min.	min.	± 1°
7/16 - 20 UNF	14	12.45	15	21	1.6	2.4	14	11.5	12°
9/16 - 18 UNF	17	15.70	18	25	1.6	2.5	15.5	12.7	12°
3/4 - 16 UNF	22	20.65	23	30	2.4	2.5	17.5	14.3	15°
7/8 - 14 UNF	27	24.00	28	34	2.4	2.5	20	16.7	15°
11/16 - 12 UN	32	29.20	33	41	2.4	3.3	23	19.0	15°
15/16 - 12 UN	41	35.55	42	49	3.2	3.3	23	19.0	15°
15/8 - 12 UN	50	43.55	51	58	3.2	3.3	23	19.0	15°

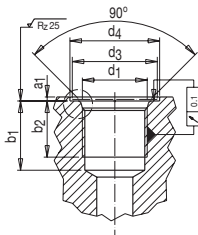

Port
 DIN ISO 6149-1.
 For O-ring sealing.

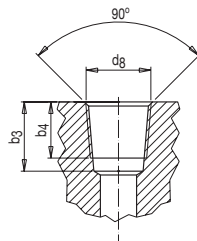

Port NPT
 ANSI / ASME B1.20.1-1983.
 For conical thread.

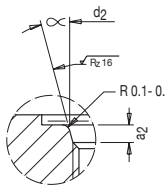

Port UNF and UN-2 B
 ISO 11926-1.
 For O-ring sealing.

* Registered trademark of BAYER AG.
 ** Registered trademark of DU PONT.

Pipe OD mm	Series	Metric										NPT		
		d ₁	d ₅	d ₂	d ₃	d ₄ *	a ₁	a ₂	b ₁	b ₂	a	d ₈	b ₃	b ₄
			-0,4	0,1	min.	min.	max.	0,4	min.	min.	w 1°		min.	min.
4	J	M 8 x 1	12	9.1	12.5	14	1	1.6	11.5	10	12	1/8"	12	10
5		--	--	--	--	--	--	--	--	--	--	--	--	--
6		M 10 x 1	14	11.1	14.5	16	1	1.6	11.5	10	12	1/8"	12	10
8		M 10 x 1	14	11.1	14.5	16	1	1.6	11.5	10	12	1/8"	12	10
6	J	M 10 x 1	14	11.1	14.5	16	1	1.6	11.5	10	12	1/8"	12	10
8		M 12 x 1.5	17	13.8	17.5	19	1.5	2.4	14	11.5	15	1/4"	17	14
10		M 14 x 1.5	19	15.8	19.5	21	1.5	2.4	14	11.5	15	1/4"	17	14
12		M 16 x 1.5	22	17.8	22.5	24	1.5	2.4	15.5	13	15	3/8"	17	14
15		M 18 x 1.5	24	19.8	24.5	26	2	2.4	17	14.5	15	1/2"	21	17
18		M 22 x 1.5	27	23.8	27.5	29	2	2.4	18	15.5	15	1/2"	21	17
22		M 27 x 2	32	29.4	32.5	34	2	3.1	22	19	15	3/4"	21	17
28		M 33 x 2	41	35.4	41.5	43	2.5	3.1	22	19	15	1"	26	21
35		M 42 x 2	50	44.4	50.5	52	2.5	3.1	22.5	19.5	15	1 1/4"	29	24
42		M 48 x 2	55	50.4	55.5	57	2.5	3.1	25	22	15	1 1/2"	29	24
6	S	M 12 x 1.5	17	13.8	17.5	19	1.5	2.4	14	11.5	15	1/4"	17	14
8		M 14 x 1.5	19	15.8	19.5	21	1.5	2.4	14	11.5	15	1/4"	17	14
10		M 16 x 1.5	22	17.8	22.5	24	1.5	2.4	15.5	13	15	3/8"	17	14
12		M 18 x 1.5	24	19.8	24.5	26	2	2.4	17	14.5	15	3/8"	17	14
14		M 20 x 1.5	27	21.8	27.5	29	2	2.4	17	14.5	15	1/2"	21	17
16		M 22 x 1.5	27	23.8	27.5	29	2	2.4	18	15.5	15	1/2"	21	17
20		M 27 x 2	32	29.4	32.5	34	2	3.1	22	19	15	3/4"	21	17
25		M 33 x 2	41	35.4	41.5	43	2.5	3.1	22	19	15	1"	26	21
30		M 42 x 2	50	44.4	50.5	52	2.5	3.1	22.5	19.5	15	1 1/4"	29	24
38		M 48 x 2	55	50.4	55.5	57	2.5	3.1	25	22	15	1 1/2"	29	24

* Type without groove for identification.

SELECTING THE CORRECT TUBE FITTING

ENGINEERING AND TECHNICAL DATA

TIGHTENING TORQUES MA FOR STUDS

Torques for studs with metal seal, form B, DIN 3852 or with soft sealing (WD) to avoid leaking.

Sealing of conical thread

Conical threads are not self-sealing. To achieve leak-free sealing, an additional sealing medium is necessary. A well-established sealing medium is a PTFE-tape (e. g. Teflon*).

Note:

The quoted figures relate to fittings out of steel (galvanised), to counter parts made of steel, and studs with soft sealing. For the type RI, the tightening torques for series "S" are to be used.

Tightening torques: pipe thread / metric thread

Series	Pipe OD	Pipe thread	Screw in thread				
			Form B MA (Nm)	with WD MA (Nm)	metric thread ISO	Form B MA (Nm)	with WD MA (Nm)
L	6	G 1/8 A	18	18	M 10 x 1.0	18	18
L	8	G 1/4 A	35	35	M 12 x 1.5	30	25
L	10	G 1/4 A	35	35	M 14 x 1.5	45	45
L	12	G 3/8 A	70	70	M 16 x 1.5	65	55
L	15	G 1/2 A	140	90	M 18 x 1.5	80	70
L	18	G 1/2 A	100	90	M 22 x 1.5	140	125
L	22	G 3/4 A	180	180	M 26 x 1.5	190	180
L	28	G 1 A	330	310	M 33 x 2.0	340	310
L	35	G 1 1/4 A	540	450	M 42 x 2.0	500	450
L	42	G 1 1/2 A	630	540	M 48 x 2.0	630	540
S	6	G 1/4 A	55	55	M 12 x 1.5	35	35
S	8	G 1/4 A	55	55	M 14 x 1.5	55	55
S	10	G 3/8 A	90	80	M 16 x 1.5	70	70
S	12	G 3/8 A	90	80	M 18 x 1.5	110	90
S	14	G 1/2 A	150	115	M 20 x 1.5	150	125
S	16	G 1/2 A	130	115	M 22 x 1.5	170	135
S	20	G 3/4 A	270	180	M 27 x 2.0	270	180
S	25	G 1 A	340	310	M 33 x 2.0	410	310
S	30	G 1 1/4 A	540	450	M 42 x 2.0	540	450
S	38	G 1 1/2 A	700	540	M 48 x 2.0	700	540

*Registered trademark of DU PONT).

PIPES – DIMENSIONS AND CHARACTERISTICS

We recommend the use of seamless precision steel tubes with dimensions to DIN 10305, part 4, material conforming St 37.4 (to DIN 10277), NBK.

Outer dia	Wall thickness	Sectional area of flow approx.	Weight	Calculated pressure
mm	mm	cm ²	kg/m	bar
4	0.75	0.049	0.060	409
4	1.00	0.031	0.074	522
6	1.00	0.130	0.123	389
6	1.50	0.071	0.166	549
6	2.00	0.031	0.197	692
6	2.25	0.017	0.208	757
8	1.00	0.280	0.173	333
8	1.50	0.200	0.240	431
8	2.00	0.130	0.296	549
8	2.50	0.071	0.339	658
10	1.00	0.500	0.222	282
10	1.50	0.380	0.314	373
10	2.00	0.280	0.395	478
10	2.50	0.190	0.462	576
10	3.00	0.130	0.518	666
12	1.00*	0.790	0.271	235
12	1.50	0.640	0.389	353
12	2.00	0.500	0.493	409
12	2.50	0.380	0.586	495
12	3.00	0.280	0.606	576
12	3.50	0.190	0.734	651
15	1.50	1.130	0.499	282
15	2.00	0.950	0.641	376
15	2.50	0.780	0.771	409
15	3.00	0.640	0.888	478
16	2.00	1.130	0.691	353
16	2.50	0.950	0.832	386
16	3.00	0.790	0.962	452
18	1.50*	1.760	0.610	235
18	2.00	1.530	0.789	313
18	2.50	1.330	0.956	392
18	3.00	1.130	1.110	409

Outer dia	Wall thickness	Sectional area of flow approx.	Weight	Calculated pressure
mm	mm	cm ²	kg/m	bar
20	2.50	1.770	1.080	353
20	3.00	1.540	1.260	373
20	3.50	1.330	1.424	426
20	4.00	1.130	1.578	478
22	2.00*	2.550	0.986	256
22	2.50	2.270	1.202	320
22	3.00	2.010	1.406	385
25	2.00*	3.460	1.134	226
25	2.50	3.140	1.387	282
25	3.00	2.830	1.628	338
25	4.00	2.260	2.072	394
25	4.50	2.010	2.275	437
25	5.00	1.760	2.466	478
28	2.00*	4.520	1.282	201
28	2.50	4.150	1.572	252
28	3.00	3.800	1.850	302
28	4.00	3.140	2.368	403
28	5.00	2.540	2.836	434
30	3.00	4.520	2.000	282
30	4.00	3.800	2.570	376
30	5.00	3.140	3.080	409
35	2.00*	7.540	1.630	161
35	2.50	7.060	2.000	201
35	3.00	6.600	2.370	242
35	4.00	5.720	3.060	322
35	5.00	4.900	3.690	403
35	6.00	4.150	4.290	419
38	4.00	7.070	3.350	297
38	5.00	6.160	4.070	371
38	6.00	5.310	4.740	390
38	7.00	4.520	5.350	446
42	3.00	10.180	2.890	201
42	4.00	9.080	3.750	269

When thin-walled tubes are subject to severe strain, parallel sleeves are recommended.

Calculated pressures have been determined in conforming to DIN 2413, scope of application is for primary static load at temperatures up to +120°C.

Characteristic values

Yield point: 235 N/mm².

Safety factor: 1.5.

Permissible variation in wall thickness: DIN 2391/sheet 1.

Calculated to DIN 2413/III for a ratio of diameters of $u = OD/ID > 1.35$.

Tubes made of stainless steel (e.g. 1.4571) to be cold-drawn seamless and heat-treated scale - free to DIN EN 10216-5-X6 CrNiMoTi17-12-2 - CFD with tolerances to DIN EN ISO 1127.

SELECTING THE CORRECT TUBE FITTING

ENGINEERING AND TECHNICAL DATA

TABLE FOR THE APPLICATION OF REINFORCING SLEEVES

Wall thickness	4	Steel tubes St 37.4 and 1.4571																								
	3.5																				○					
	3																				○					
	2.5											○	○								○	●				
	2											○	○	○	○						○	○	●	●		
	1.5											○	○	○	●	●					○	●	●	●	●	
	1											○	●	●	●	●	●				○	●	●	●	●	●
	0.75				●	●	●	●	●	●	●	●	●	●	●	●	●	●	●	●	●	●	●	●	●	●
0.5		●	●	●	●	●	●	●	●	●	●	●	●	●	●	●	●	●	●	●	●	●	●	●	●	
Pipe OD	4		6	8	6	8	10	15	15	18	22	28	35	42	6	8	10	12	14	16	20	25	30	38		
Series		LL				L										S										

Wall thickness	4	For soft metal tubes																										
	3.5																								●			
	3													●	●									●	●			
	2.5												●	●	●	●							●	●	●	●		
	2												●	●	●	●						●	●	●	●	●		
	1.5																					○	●	●	●	●		
	1																					○	●	●	●	●		
	0.75			●	●	●	●	●	●	●	●	●	●	●	●	●	●	●	●	●	●	●	●	●	●	●		
0.5		●	●	●	●	●	●	●	●	●	●	●	●	●	●	●	●	●	●	●	●	●	●	●	●			
Pipe OD	4		6	8	6	8	10	15	15	18	22	28	35	42	6	8	10	12	14	16	20	25	30	38				
Series		LL				L										S												

● VSH is always required.

○ VSH is recommended; particularly in case of frequent loosening and in connection with heavily loaded lines (vibrations).

PORT CONNECTIONS AND SEALS FOR TEST COUPLINGS

Form A			
G	d ₁	t ₁	t ₂
M8x1	9.5+0.1	11	15.5
M10x1	11.5+0.1	12	16.5

Form B				
G	d ₁	t ₁	t ₂	a
M14x1.5	20	12	18.5	1
M16x1.5	22	12	18.5	1
G1/4	19	12	18.5	1
G3/8	23	12	18.5	1.5

Form C				
G	d ₁	t ₁	t ₂	a
M12x1.5	18	12	18.5	1
G1/8	15	8	13	1
G1/4	19	12	18.5	1

Form D			
G	type	t ₁	t ₂
R1/8	taper	5.5	9.5
R1/4	taper	8.5	13.5
1/8	NPT	9	13.5
1/4	NPT	12	18.5

Form E						
G	type	d ₁	d ₂	t ₁	t ₂	a
9/16-24	UNF	9.1	17	10	12	1.9
7/16-20	UNF	12.4	21	11.5	14	2.4
1/2-20	UNF	14	23	11.5	14	2.4
9/16-18	UNF	15.6	25	12.7	15.5	2.5

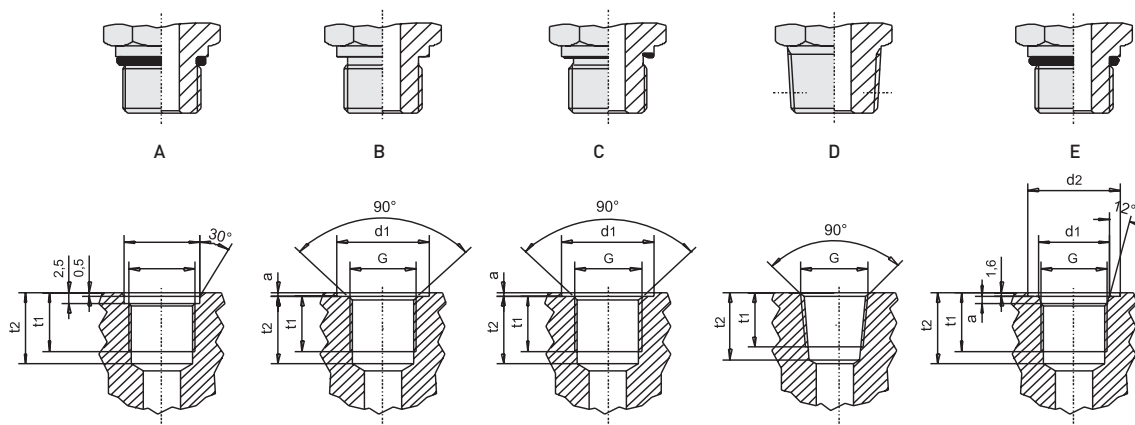

SELECTING THE CORRECT TUBE FITTING

ENGINEERING AND TECHNICAL DATA

TEST HOSES TECHNICAL DATA

Order code		A	B	C
Nominal bore		DN2	DN2	DN4
max. working pressure	bar	400	630	340
burst pressure	bar	1100	1900	850
testing pressure	bar	600	950	570
pressure rating at 0°C	bar	488	768	463
pressure rating at 30°C	bar	440	693	418
pressure rating at 50°C	bar	400	630	380
pressure rating at 80°C	bar	344	542	327
pressure rating at 100°C	bar	308	485	293
working temperature	°C	-30 to 100 momentary		
inside diameter	mm	2	2	4
outside diameter	mm	5	5	8.6
bending radius	mm	20	20	40
max. coil length	m	30	30	60
weight/meter	g	16	16	42
inner and outer tube wall		PA	PA	PA
reinforcement		synthetic fibre		

REDUCING COUPLINGS - EXAMPLES

The great variety of reducers can be restricted by the use of standard screw joints. The desired combination can be provided in short-notice cases of demand or in cases of small quantities.

Straight male thread screw joint

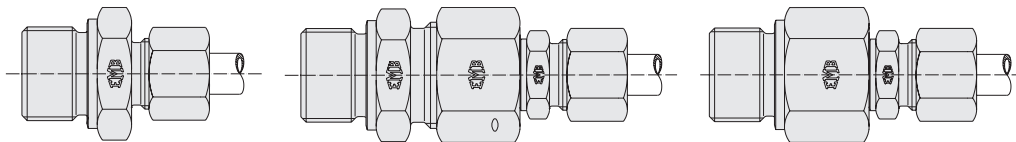

Pipe outside diameter 14 mm
Male thread R 1"
Series S

Combination possible from:
Straight male thread screw joint with male thread R 1" (for instance A 25-RS) and reducing screw joint RSDK0 25/14. Threaded reducing socket RI 1"-1/2" and straight male thread screw joint A 14-RS.

Straight screw joint

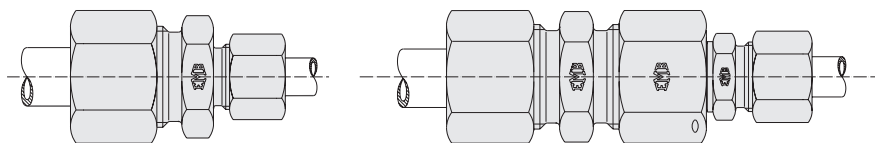

1st pipe outside diameter 30 mm
2nd pipe outside diameter 20 mm
Series S

Combination possible from:
Straight screw joint E 30-S.
Reducing screw joint RSDK0 30/20.

L-shaped male thread screw joint

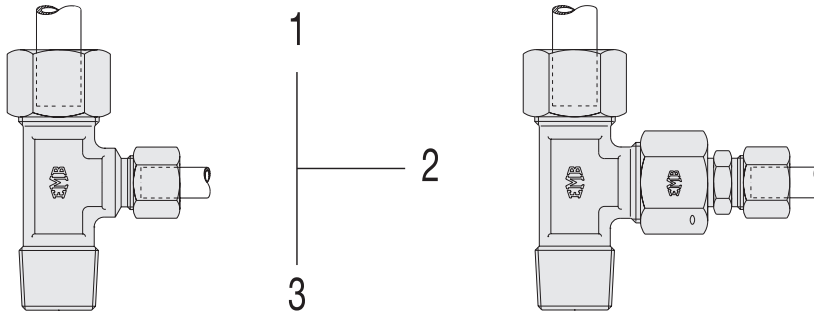

1st pipe outside diameter 16 mm
 2nd pipe outside diameter 10 mm
 Male thread NPT
 Series S
 Order pattern 1-2-3

Combination possible from:
 L-shaped male thread screw joint.
 D 16-S/NPT and reducing screw joint RSDKO 16/10.

T-screw joint

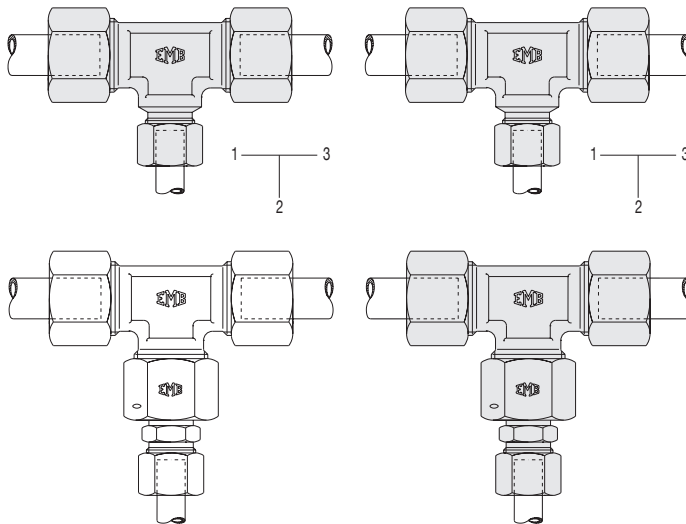

1st pipe outside diameter 12 mm
 2nd pipe outside diameter 8 mm
 3rd pipe outside diameter 12 mm
 Series S
 Order pattern 1-2-3

Combination possible from:
 T-screw joint G 12-S.
 Reducing screw joint RS 12/8.

Similarly it is possible to provide reducing screw joint assemblies also in other configurations and combinations.

Further combinations are offered by using the straight male thread socket VADKO.

SELECTING THE CORRECT TUBE FITTING

ENGINEERING AND TECHNICAL DATA

WELDING NIPPLE TYPE SCREW JOINTS - TECHNIQUE

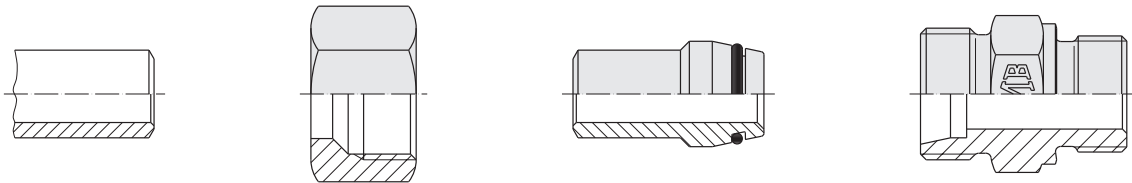

In particularly intricate working conditions Gates-EMB welding nipple type screw joints will come to use with:

- › Extreme vibrations
- › Pulsating loads
- › Very heavy pressure surges
- › Extreme temperatures and fluctuations in temperature
- › In systems where outages lead to high cost

Welding nipples can be easily complemented using solder less pipe screw joints according to DIN 2352/ISO 8434-1. The cutting ring is removed and the welding nipple is fitted in its place.

The working-pressure (PB) of complete welding nipple fittings is determined by the component showing the lowest pressure (pipe, welding-nipple, fittings).

The oiled steel welding cone SNO corresponds to DIN 3865, form A.

Steel based welding nipples can be welded appropriately with common methods.

The choice of the welding additive in accordance to DIN 8556 has to be chosen by considering the welding method and the specific application.

WELDING NIPPLE TYPE SCREW JOINTS - ASSEMBLY

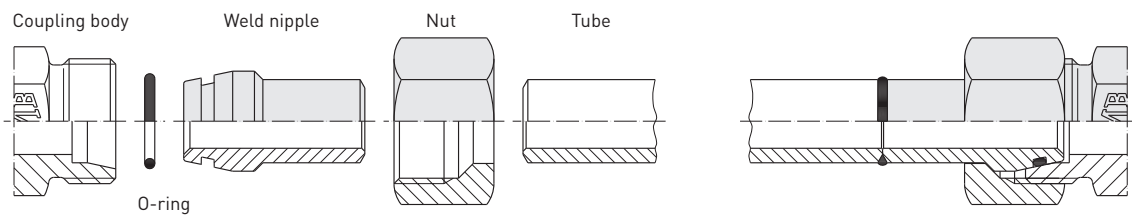

Determining the tube length.

Measure distance between fitting ends.

Deduct dimension X from each fitting.

Reduce pipe end by L1 when cutting rings have to be replaced.

Cut the tube at right angles.

Chamfer tube outside end.

Deburr for welding purposes inside.

Clean appropriately.

Place the nut on the welding nipple.

Weld nipple and tube.

Descale the weld and clean the O-ring groove.

Place the separately supplied O-ring.

Oil the thread.

O-ring must not be twisted.

Tighten nut by hand.

The nut has to be tightened by 1/3 of a turn beyond the point of a noticeable increase in force.

Hold the fitting body by means of a spanner.

While assembling, torsion in the connecting tube must be avoided.

Application of deviating numbers of tightening turns reduces the nominal pressure rating and the life of the fitting which causes leakages or other reasons of failure.

FLARE COUPLING DIN 24° - CHARACTERISTICS

Function of the flare fitting

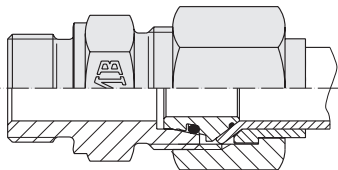

Before tightening the nut

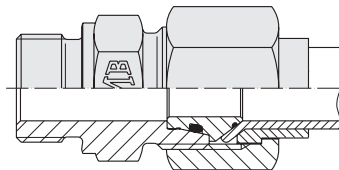

After tightening the nut

Gates-EMB flare fitting's ideal design, which consists of four components, ensures the secure and tight connection of flared tubes and standardised fitting bodies according to DIN 2353 / ISO 8434-1 and 4.

Fitting components:

Fitting body to DIN / ISO.

Flare adaptor DIN 3949.

Support ring DIN 3949.

Nut DIN 3949.

The central component – flare adaptor – effects the transition from the 24° taper of the fitting body to the SAE 37° flare connection. O-rings ensure sealing at the body taper and the flare connection. Thus a high degree of sealing efficiency is ensured, even under alternating pressure load. As the nut is tightened, the flare adaptor is pressed into the fitting taper with deformation of the retaining collar, until the collar at the flare adaptor is in full contact with the fitting body thus preventing further penetration and detrimental expansion of the fitting body. Having been tightened, the centre unit is captured in the fitting body – a great help to the operator during reassembly. The fitting can be dismantled and reassembled as often as necessary. The support ring provides secure and notch free tube clamping and high fatigue resistance under bending load.

SELECTING THE CORRECT TUBE FITTING

ENGINEERING AND TECHNICAL DATA

Flare tube fittings

High degree of fine sealing efficiency
Elastomeric sealing at both sectioning points.
No setting of the connection.

No setting of the connection

Improved connection between centre unit and fitting body.
Reduced surface pressure between tube and support ring.

Secure tube connection

Larger flare and adapted loose collar.
High tensile strength.
No risk of disconnection when tightened insufficiently.

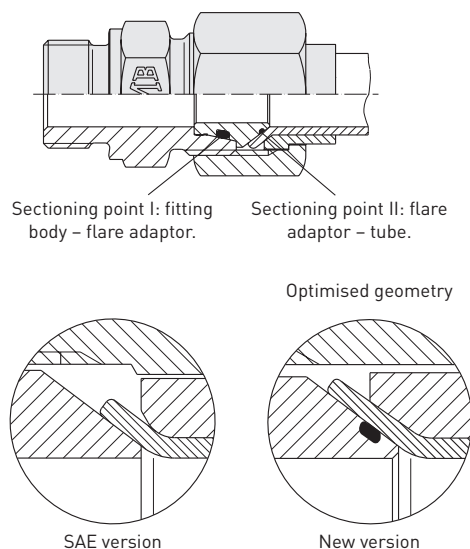

FLARE COUPLING DIN 24° - ASSEMBLY

Assembly/reassembly

- Cut the tube rectangularly. Do not use a pipe cutter!
- Deburr the tube inside and outside. Do not chamfer!
- Clean off swarf and dirt.
- Lubricate flare connection parts and place them on the pipe. For stainless steel couplings (e.g. 1.4571) it is necessary to use a special lubricant (Gates-EMB lubricant "Gleitpaste").
- Flare pipe end. Check for possible cracks.
- Insert flare adaptor into coupling and apply flared pipe to the body. Tighten by hand.
- Use spanner to tighten with one to one and a half turn.
- Each time the coupling is disconnected, the nut must be retightened without using excessive force.

Material

Flare fittings are machined from drawn steel bars or forgings.

The surface is phosphated and oiled (ISO 4042). Other surface protections are available.

Stainless steel (1.4571) is available.

Serial seal is NBR (e.g. Perbunan*).

Temperature range from -35°C to +100°C.

FKM upon request (e.g. Viton*).

Temperature range from -25°C to +200°C.

When using different materials for fittings and seals, the lowest temperature limits must be respected.

A tube quality suitable for flaring should be used, preferably a seamless precision steel tube of DIN 2391/C material St. 35, NBK.

Nominal pressures

Gates-EMB flare fittings are made in two different series. These are suitable for use at the following pressures:

Series	Pipe OD	Nominal pressure
L	6-10	500 bar
L	12-18	400 bar
L	22-42	250 bar
S	6-16	630 bar
S	20-38	400 bar

When the nominal pressure for certain type of fittings differ from those shown above, the nominal pressures indicated for the individual types should be taken into account.

The nominal pressure of steel-type flare fittings is based on a safety factor of 4 [DIN 3859]. Use at lower pressure range consequently results in higher safety. The nominal pressure presupposes uniform load conditions at temperatures up to +120°C. Allowances must be made for working conditions involving heavy impact pressure, mechanical strain and vibration.

* Registered trademark of BAYER AG.

** Registered trademark of DU PONT.

SELECTING THE CORRECT TUBE FITTING

ENGINEERING AND TECHNICAL DATA

FLARE COUPLING DIN 24° - TUBE DIMENSION

Determining the tube length

The correct tube length is determined by measuring the distance between the fitting body ends. Dimension X is then deducted from each connection.

Tube dimension	X	L ₁
6x1	1	8
6x1.5	2	9
8x1	1	8
8x1.5	2	9
8x2	2.5	9.5
10x1	1	8
10x1.5	2	9
10x2	3	10
12x1	1	8
12x1.5	2	9
12x2	3	10
14x1.5	0.5	8.5
14x2	1	9
14x2.5	2	10
14x3	3	11
15x1.5	1	8
15x2	2	9
15x2.5	3	10
16x1.5	0	8.5
16x2	1	9.5
16x2.5	1.5	10
16x3	2.5	11
18x1.5	0	7.5
18x2	1	8.5
18x2.5	1.5	9
20x2	1	11.5
20x2.5	2	12.5
20x3	3	13.5
20x3.5	4	14.5
22x1.5	1	8.5
22x2	2	9.5
22x2.5	3	10.5
22x3	3.5	11
25x2	1	13
25x2.5	1.5	13.5
25x3	2.5	14.5
25x4	4	16
28x2	1.5	9
28x2.5	2.5	10
28x3	3	10.5
30x2	0.5	13
30x2.5	0.5	14
30x3	1	14.5
30x4	3	16.5
30x5	4.5	18
35x2	1.5	12
35x2.5	2	12.5
35x3	3	13.5
35x4	4.5	15
38x2.5	0	16
38x3	0.5	16.5
38x4	2	18
38x5	4	20
42x2	1.5	12.5
42x3	3	14
42x4	4.5	15.5

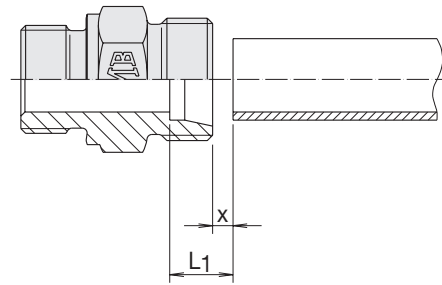

Checking the flared tube

Tube cut off at right angles; lightly deburr both inside and outside. Do not chamfer.

If the flare is too short, perfect function of the fitting cannot be guaranteed!

Tube dimension dxs	Check dia Da min	Check dia Da max
6x1	9.1	10
6x1.5	9.1	10
8x1	11.3	12
8x1.5	11.3	12
8x2	11.3	12
10x1	13.1	14
10x1.5	13.1	14
10x2	13.1	14
12x1	15.3	16
12x1.5	15.3	16
12x2	15.3	16
14x1.5	18.6	19.6
14x2	18.6	19.6
14x2.5	18.6	19.6
14x3	18.6	19.6
15x1.5	19.1	20
15x2	19.1	20
15x2.5	19.1	20
16x1.5	20.6	22
16x2	20.6	22
16x2.5	20.6	22
16x3	20.6	22
18x1.5	23.2	24
18x2	23.2	24
18x2.5	23.2	24
20x2	25.6	26.8
20x2.5	25.6	26.8
20x3	25.6	26.8
20x3.5	25.6	26.8
22x1.5	26.5	27.5
22x2	26.5	27.5
22x2.5	26.5	27.5
22x3	26.5	27.5
25x2	31.1	33
25x2.5	31.1	33
25x3	31.1	33
25x4	31.1	33
28x2	32.7	33.3
28x2.5	32.7	33.3
28x3	32.7	33.3
30x2	37	38.7
30x2.5	37	38.7
30x3	37	38.7
30x4	37	38.7
30x5	37	38.7
35x2	41.8	42.7
35x2.5	41.8	42.7
35x3	41.8	42.7
35x4	41.8	42.7
38x2.5	46	47.2
38x3	46	47.2
38x4	46	47.2
38x5	46	47.2
42x2	48.8	49.8
42x3	48.8	49.8
42x4	48.8	49.8

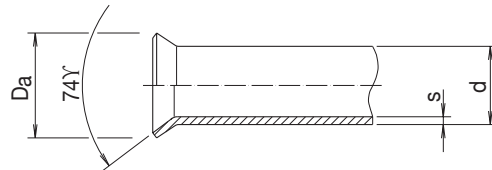

SELECTING THE CORRECT TUBE FITTING

ENGINEERING AND TECHNICAL DATA

Straight tube length to start of bending radius

Bend first – flare later

Straight tube length (L_1) to start of bending radius:

- Manual flaring tool
- Flaring machine

Tube OD	L_1 Flaring machine UNIPRESS
6	43
8	44
10	46
12	47
14	50
15	50
16	52
18	58
20	58
22	60
25	60
28	60
30	62
35	62
38	70
42	70

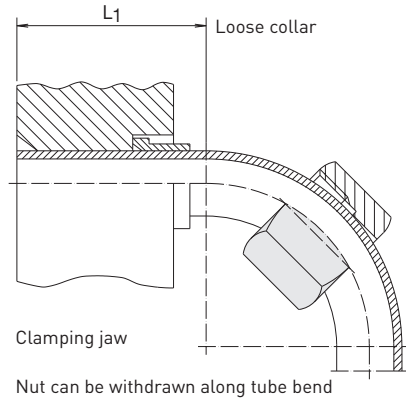

Flare first – bend later

If installation problems demand that the straight tube length (dimension L_2) has to be shorter than indicated in the table, bending must be carried out after flaring.

Tube OD	L_2
10	15
12	15
15	17
16	21
18	18

Tube OD 6, 8 and 14 upon request.

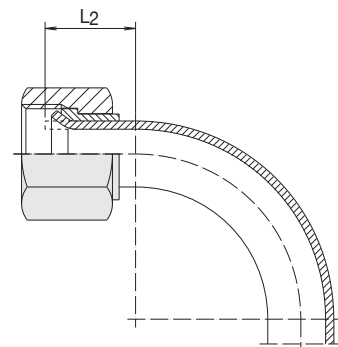

Minimum straight tube length L

Tube OD	Series	L Flaring machine UNIPRESS
6	L	59
8	L	62
10	L	64
12	L	67
15	L	75
18	L	76
22	L	81
28	L	88
35	L	92
42	L	130
6	S	61
8	S	64
10	S	66
12	S	68
14	S	74
16	S	79
20	S	82
25	S	94
30	S	96
38	S	136

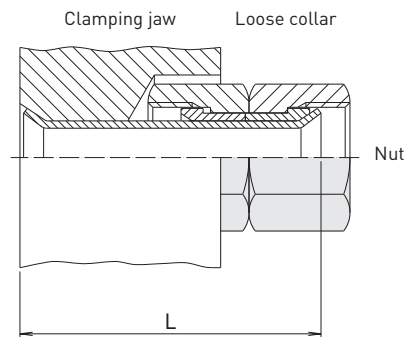
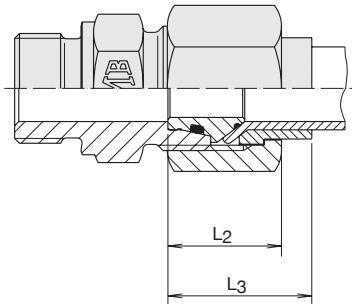

Table for length correction



The dimensions marked X in the following table represent the tube wall thicknesses on which the lengths in the lists of dimensions are based. For other tube wall thicknesses, the lengths have to be modified by the corrected dimension taken from the table.

Tube OD	Series	L2	L3
6	L	17.5	20.5
8	L	18.5	21.5
10	L	19.5	24
12	L	20	24.5
15	L	21.5	25.5
18	L	23	27
22	L	24	30.5
28	L	26	31.5
35	L	30	36
42	L	34	40
6	S	17.5	20.5
8	S	18.5	21.5
10	S	20	24.5
12	S	20.5	25
14	S	23	27.5
16	S	25	31
20	S	27.5	33
25	S	31	38.5
30	S	33	41.5
38	S	37.5	48

Tube OD	Series	Corrective dimension Tube wall thickness							
		1	1,5	2	2,5	3	3,5	4	5
6	L	X	+1						
8	L	X	+1	1.5					
10	L	-1	X	+1					
12	L	-1	X	+1					
15	L		X	+1	+2				
18	L		-1	X	+1				
22	L		-1	X	+1	1.5			
28	L			-1.5	-0.5	X			
35	L			-1.5	-1	X		1.5	
42	L			-1.5		X		1.5	
6	S	X	+1						
8	S	X	+1	1.5					
10	S	-1	X	+1					
12	S	-1	X	+1					
14	S		-0.5	X	+1	+2			
16	S		-1	X	0.5	1.5			
20	S			X	+1	+2	3		
25	S			-1.5	-1	X		1.5	
30	S			-2	-1	X		+2	3.5
38	S				-0.5	X		1.5	3.5

CONVERSION TABLES

ENGINEERING AND TECHNICAL DATA

HOW TO INTERPRET ?

The following table gives rationalised conversion pressures from MPa to psi according to the SAE J517 standard for hydraulic hoses (revised March 2006). These reference pressures allow the user to relate the new MPa pressure number to the former even psi number, 3000 psi relates to 21 MPa with the mathematically correct conversion being 21 MPa equal to 3045 psi. Allowing for the use of the most common available pressures this table will assist in relating the old psi numbers to the new ISO standards that will use either MPa or Bar.

MPA TO PSI

MPa	Bar	Relative psi	Actual psi
3.5	35	500	507.5
7	70	1000	1015
14	140	2000	2030
21	210	3000	3045
28	280	4000	4060
35	350	5000	5075
42	420	6000	6090
49	490	7000	7105

Note: 1MPa = 10 Bar = 145 psi

INCHES - MILLIMETRES

Inches		Millimetres
Fraction	Decimals	
1/64	0.015625	0.397
1/32	0.03125	0.794
3/64	0.046875	1.191
1/16	0.0625	1.588
5/64	0.078125	1.984
3/32	0.09375	2.381
7/64	0.109375	2.778
1/8	0.125	3.175
9/64	0.140625	3.572
5/32	0.15625	3.969
11/64	0.171875	4.366
3/16	0.1875	4.763
13/64	0.203125	5.159
7/32	0.21875	5.556
15/64	0.234375	5.953
1/4	0.250	6.350
17/64	0.265625	6.747
9/32	0.28125	7.144
19/64	0.296875	7.541
5/16	0.3125	7.938
23/64	0.359375	9.128
3/8	0.375	9.525
25/64	0.390625	9.922
13/32	0.40625	10.319
27/64	0.421875	10.716
7/16	0.4375	11.113
29/64	0.453125	11.509
15/32	0.46875	11.906
31/64	0.484375	12.303
1/2	0.500	12.700
33/64	0.515625	13.097
17/32	0.53125	13.494
35/64	0.546875	13.891

Inches		Millimetres
Fraction	Decimals	
9/16	0.5625	14.288
37/64	0.578125	14.684
19/32	0.59375	15.081
39/64	0.609375	15.478
5/8	0.625	15.875
41/64	0.640625	16.272
21/32	0.65625	16.669
11/16	0.6875	17.463
45/64	0.703125	17.859
23/32	0.71875	18.256
47/64	0.734375	18.653
3/4	0.750	19.050
49/64	0.765625	19.447
25/32	0.78125	19.844
51/64	0.796875	20.241
13/16	0.8125	20.638
53/64	0.828125	21.034
27/32	0.84375	21.431
55/64	0.859375	21.828
7/8	0.875	22.225
57/64	0.890625	22.622
29/32	0.90625	23.019
59/64	0.921875	23.416
15/16	0.9375	23.813
61/64	0.953125	24.209
31/32	0.96875	24.606
63/64	0.984375	25.003

METRIC (SI) - IMPERIAL UNITS FOR HOSE AND CONNECTORS USE

Quantity	Imperial unit	Metric (SI) unit	Conversion from imperial to SI unit	Conversion from SI to imperial unit
Area	Square inch (in ²)	Square metre (m ²)	(in ²) x (6.4516 x 10 ⁻⁴) = (m ²)	(m ²) x 1550.003 = (in ²)
Force	Pound (lbf)	Newton (N)	(lbf) x 4.4482 = (N)	(N) x (2.2481 x 10 ⁻¹) = (lbf)
Frequency	Cycles/second (cps)	Hertz (Hz)	1 (cps) = 1 (Hz)	1 (Hz) = 1 (cps)
Length	Inch (in)	Metre (m)	(in) x (2.540 x 10 ⁻²) = (m)	(m) x 39.370 = (in)
Mass	Pound (lbm)	Kilogram (kg)	(lbm) x 0.4536 = (kg)	(kg) x 2.2046 = (lbm)
Power	Electric horsepower (HP)	Watt (W)	(HP) x (7.460 x 10 ²) = (W)	(W) x (1.3405 x 10 ⁻³) = (HP)
Pressure	Pounds/sq in (psi)	Newtons/sq metre (N/m ²)	(psi) x (6.8948 x 10 ³) = (N/m ²)	(N/m ²) x (1.4504 x 10 ⁻⁴) = (psi)
	(psi) (psi) (bar)	Mega Pascal (MPa) Bar (bar) (N/m ²)	[Non-preferred conversions] psi/145 = MPa psi/14.5 = bar (bar) x 100000 = (N/m ²)	(MPa) x 145 = (psi) (bar) x (1.4504 x 10 ⁴) = (psi) (N/m ²) x (1.00 x 10 ⁻⁵) = (bar)
Temperature	Degrees Fahrenheit (°F)	Degrees Celsius (°C)	(°Celsius) = 0.556 (°F-32)	(1.8°C) + 32 = °F
Torque	Pound-inch (lbf-in)	Newton-metres (Nm)	((lbf-in) x (1.1298 x 10 ⁻¹) = (Nm)	(Nm) x 8.8507 = ((lbf-in)
Volume	US gallon (gal)	Cubic metre (m ³)	(gal) x (4.543 x 10 ⁻³) = (m ³)	(m ³) x (2.201 x 10 ²) = (gal)
		Litre (l)	[Non-preferred conversions] (gal) x 4.543 = (l)	(l) x (2.201 x 10 ⁻¹) = (gal)
Work	Foot-pound (ft-lbf)	Joule (J)	(ft-lbf) x 1.3558 = (J)	(J) x (7.3756 x 10 ⁻¹) = (ft-lbf)

PRODUCT INDEX

INTEGRATED FLUID POWER SOLUTIONS

Ref.	P.	Ref.	P.	Ref.	P.
4FBSPP-4FBSPP	320	4G4FFORX90L	254	4G6FDLORX90	266
4FBSPPX-4FBSPPX	319	4G4FFORX90M	253	4G6FFORX	250
4FBSPPX-4FBSPPX-4FBSPPX	325	4G4FFORX90S	252	4G6FFORX45S	251
4FBSPPX-4FBSPPX-4MBSPP	326	4G4FJISX	249	4G6FFORX90L	254
4FBSPPX-4FBSPPX90BL	322	4G4FJX	243	4G6FFORX90M	253
4FBSPPX-4FBSPPX90SWT	323	4G4FJX45S	244	4G6FFORX90S	252
4FBSPPX-6FBSPPX	319	4G4FJX90L	247	4G6FJX	243
4FBSPPX-8FBSPPX	319	4G4FJX90M	246	4G6FJX45S	244
4FBSPPX-CAP	327	4G4FJX90S	245	4G6FJX90L	247
4FJ-CAP	347	4G4FKX	249	4G6FJX90M	246
4FJ-NUT	348	4G4FP	274	4G6FJX90S	245
4FJX-2MBSPPCOR	345	4G4FPX	273	4G6FP	274
4FJX-4MBSPPCOR	345	4G4FQLH	283	4G6FSX	255
4G1	51	4G4FSX	255	4G6MB	276
4G10DBJ	272	4G4FSX90	256	4G6MBSPP	241
4G10FDHORX	268	4G4MB	276	4G6MBSPT	236
4G10FDHORX45	269	4G4MBSPP	241	4G6MBX	276
4G10FDHORX90	270	4G4MBSPPBKHD	241	4G6MBX90	277
4G10FDLORX	264	4G4MBSPT	236	4G6MDL	267
4G10FDLORX45	265	4G4MFA	259	4G6MFFOR	255
4G10FDLORX90	266	4G4MFFOR	255	4G6MJ	248
4G10MDH	271	4G4MIX	257	4G6MP	273
4G10MDL	267	4G4MIX90	258	4G6MPLN	274
4G10MSP	271	4G4MJ	248	4G6MPX	275
4G10PWSP	281	4G4MP	273	4G6MPX90	275
4G12DBJ	272	4G4MPLN	274	4G6MSP	271
4G12FDHORX	268	4G4MPX	275	4G8FDHORX	268
4G12FDHORX45	269	4G4MPX90	275	4G8FDHORX45	269
4G12FDHORX90	270	4G4MQLH	282	4G8FDHORX90	270
4G12FDLORX	264	4G4MQLH45	282	4G8FDLORX	264
4G12FDLORX45	265	4G4MQLH90S	283	4G8FDLORX45	265
4G12FDLORX90	266	4G4MS	257	4G8FDLORX90	266
4G12MDL	267	4G4PL	280	4G8FFORX	250
4G13FFGX	278	4G5FJX	243	4G8FFORX90L	254
4G14DBJ	272	4G5FJX45-011	244	4G8MBSPP	241
4G15FPWX	281	4G5FJX90-023	245	4G8MDH	271
4G16DBJ	272	4G5FJX90L	247	4G8MDL	258
4G18DBJ	272	4G5FJX90M	246	4G8MP	273
4G1H	67	4G5FSX	255	4G8MPX	275
4G2	50	4G5MB	276	4G8MSP	271
4G2FBSPX	237	4G5MFA	259	4GTH	56
4G2FP	274	4G5MIX	257	4LOC10DBJ	293
4G2L	66	4G5MIX90	258	4LOC4FBSPPX	290
4G2MP	273	4G5MJ	248	4LOC4FBSPPX90	290
4G2XH	64	4G6BSPBJ	242	4LOC4FJX	291
4G3H	55	4G6FBSPORX	237	4LOC4MBSPP	291
4G4BSPBJ	242	4G6FBSPORX45	238	4LOC4MP	293
4G4FBSPORX	237	4G6FBSPORX90	239	4LOC4FDLX	292
4G4FBSPORX45	238	4G6FBSPORX90BL	240	4LOC4FDLX90	292
4G4FBSPORX90	239	4G6FDHORX	268	4LOC8FDLX	292
4G4FBSPORX90BL	240	4G6FDHORX90	270	4LOC8FDLX90	292
4G4FFORX	250	4G6FDLORX	264	4LOC8MSP	293
4G4FFORX45S	251	4G6FDLORX45	265	4M3K	46

Ref.	P.	Ref.	P.	Ref.	P.
4M3KH	63	4MJ-2MBSPPCOR	332	5G10PWSP	281
4M4K	45	4MJ-2MBSPPWD	333	5G11PWSP	281
4M4KH	61	4MJ-2MJ	340	5G12DBJ	272
4M4KL	62	4MJ-2MP	346	5G12FDHORX	268
4M5K	44	4MJ-2MP90	346	5G12FDHORX45	269
4M6K	43	4MJ-4FJX45	343	5G12FDHORX90	270
4MBSPP-10MBSPP	311	4MJ-4FJX-4MJ	344	5G12FDLORX	264
4MBSPP-10MM	316	4MJ-4FJX90	343	5G12FDLORX45	265
4MBSPP-12FBSPPX	318	4MJ-4MB	337	5G12FDLORX90	266
4MBSPP-12MBSPP	311	4MJ-4MBA45	338	5G12MDH	271
4MBSPP-12MBSPPWD	312	4MJ-4MBA-4MJ	339	5G12MDL	267
4MBSPP-12MM	316	4MJ-4MBA90	338	5G12MSP	271
4MBSPP-14MM	316	4MJ-4MBSPPACOR45	335	5G13FFGX	278
4MBSPP-16MBSPP	311	4MJ-4MBSPPACOR90	334	5G13FFGX90	279
4MBSPP-16MM	316	4MJ-4MBSPPCOR	332	5G13MFG	279
4MBSPP-18MM	316	4MJ-4MBSPPWD	333	5G14DBJ	272
4MBSPP-20MM	316	4MJ-4MJ	340	5G14FDHORX	268
4MBSPP-22MB	316	4MJ-4MJ-2MBSPPACOR	336	5G14FDHORX90	270
4MBSPP-2FBSPPX	318	4MJ-4MJ-4FJX	344	5G15FPWX	281
4MBSPP-2MBSPT	314	4MJ-4MJ-4MBA	339	5G16DBJ	272
4MBSPP-2MBSPPWD	312	4MJ-4MJ-4MJ	341	5G18AV	280
4MBSPP-4MBSPPBKHD	313	4MJ-4MJ90	340	5G18DBJ	272
4MBSPP-4FBSPPX	318	4MJ-4MJBKHD	341	5G2	50
4MBSPP-4FBSPPX45BL	321	4MJ-4MJBKHD45	342	5G4MBSPP	241
4MBSPP-4FBSPPX-4FBSPPX	325	4MJ-4MJBKHD90	342	5G4MP	273
4MBSPP-4FBSPPX-4MBSPP	324	4MJ-4MP	346	5G5FJX	243
4MBSPP-4FBSPPX90BL	321	4MJ-4MP90	346	5G5FJX45-011	244
4MBSPP-4FBSPPX90SWT	322	4MJ-6MB	337	5G5FJX90M	246
4MBSPP-4MB	315	4MJ-6MBA90	338	5G5MJ	248
4MBSPP-4MBSPP	310	4MJ-6MBSPPACOR90	334	5G6FBSPORX	237
4MBSPP-4MBSPP-4FBSPPX	324	4MJ-6MBSPPCOR	332	5G6FBSPORX45	238
4MBSPP-4MBSPP-4MBSPP	323	4MJ-6MBSPPWD	333	5G6FBSPORX90	239
4MBSPP-4MBSPP90BL	320	4MJ-6MP	346	5G6FFORX	250
4MBSPP-4MBSPT	314	4MJ-8MBSPPCOR	332	5G6FFORX45S	251
4MBSPP-4MBSPPWD	312	4MJ-8MBSPPWD	333	5G6FFORX90S	252
4MBSPP-4MP	317	4MJ-PLUG	347	5G6FJX	243
4MBSPP-6FBSPPX	318	4TH7	53	5G6FJX45S	244
4MBSPP-6MB	315	4TH7DL	54	5G6FJX90M	246
4MBSPP-6MBSPP	311	4TH8	52	5G6FJX90S	245
4MBSPP-6MBSPT	314	5C5CXH	81	5G6FSX	255
4MBSPP-6MBSPPWD	312	5FJ-CAP	347	5G6MBSPP	241
4MBSPP-8FBSPPX	318	5FJ-NUT	348	5G6MBSPT	236
4MBSPP-8MB	315	5FJX-2MBSPPCOR	345	5G6MFFOR	255
4MBSPP-8MBSPP	311	5G1	51	5G6MJ	248
4MBSPP-8MBSPT	314	5G10FDHORX	268	5G6MP	273
4MBSPP-8MBSPPWD	312	5G10FDHORX45	269	5G8FBFFX	242
4MBSPP-PLUG	326	5G10FDHORX90	270	5G8FBSPORX	237
4MEGATECH1000	82	5G10FDLORX	264	5G8FDLORX	264
4MJ-10MMACOR90	331	5G10FDLORX45	265	5G8FDLORX45	265
4MJ-10MMOR	330	5G10FDLORX90	266	5G8FDLORX90	266
4MJ-2MBSPPACOR45	335	5G10MDH	271	5G8MDL	267
4MJ-2MBSPPACOR-4MJ	336	5G10MDL	267	5G8MSP	271
4MJ-2MBSPPACOR90	334	5G10MSP	271	5GTH	56

PRODUCT INDEX

INTEGRATED FLUID POWER SOLUTIONS

Ref.	P.	Ref.	P.	Ref.	P.
5M3K	46	6FJX-6MBSPPCOR	345	6G2L	66
5M3KH	63	6G1	51	6G2XH	64
5M4K	45	6G10FDHORX	268	6G3H	55
5M4KL	62	6G10FDHORX45	269	6G4BSPBJ	242
5M5K	44	6G10FDHORX90	270	6G4FFORX	250
5MJ-12MMAOR90	330	6G10FDLORX	264	6G4FFORX45S	251
5MJ-2MBSPPACOR90	334	6G10FDLORX45	265	6G4FFORX90S	252
5MJ-2MBSPPWD	333	6G10FDLORX90	266	6G4FJX	243
5MJ-2MP	346	6G10FFORX	250	6G4FJX45S	244
5MJ-4MB	337	6G10FJX	243	6G4FJX90L	247
5MJ-4MBSPPACOR90	334	6G10FJX90M	246	6G4FJX90S	245
5MJ-4MBSPPWD	333	6G10MB	276	6G4FP	274
5MJ-4MJ	340	6G10MBX	276	6G4MBSPP	241
5MJ-4MP	346	6G10MBX90	277	6G4MFA	259
5MJ-5FJX45	343	6G10MDH	271	6G4MIX45	258
5MJ-5FJX-5MJ	344	6G10MDL	267	6G4MIX90	258
5MJ-5FJX90	343	6G10MFFOR	255	6G4MP	273
5MJ-5MB	337	6G10MJ	248	6G4MPLN	274
5MJ-5MBA-5MJ	339	6G10MSP	271	6G4MPX	275
5MJ-5MBA90	338	6G10PWSP	281	6G4MPX90	275
5MJ-5MJ	340	6G11PWSP	281	6G5FJX	243
5MJ-5MJ-5FJX	344	6G12DBJ	272	6G5MFA	259
5MJ-5MJ-5MBA	339	6G12FDHORX	268	6G5MIX	257
5MJ-5MJ-5MJ	341	6G12FDHORX45	269	6G5MIX45	258
5MJ-5MJ90	340	6G12FDHORX90	270	6G5MIX90	258
5MJ-5MJBKHD	341	6G12FDLORX	264	6G6BSPBJ	242
5MJ-5MJBKHD45	342	6G12FDLORX45	265	6G6FBFFX	242
5MJ-5MJBKHD90	342	6G12FDLORX90	266	6G6FBSPORX	237
5MJ-6MB	337	6G12MB	276	6G6FBSPORX45	238
5MJ-6MBSPPACOR90	334	6G12MDH	271	6G6FBSPORX90	239
5MJ-6MBSPPWD	333	6G12MDL	267	6G6FBSPORX90BL	240
5MJ-PLUG	347	6G12MSP	271	6G6FFORX	250
5TH7	53	6G13FFGX	278	6G6FFORX45S	251
5TH7DL	54	6G13FFGX45	278	6G6FFORX90L	254
6C5CXH	81	6G13FFGX90	279	6G6FFORX90M	253
6CM2TDL-XTF	49	6G13MFG	279	6G6FFORX90S	252
6EFG4K	40	6G14DBJ	272	6G6FJISX	249
6EFG4KL	60	6G14FDHORX	268	6G6FJX	243
6EFG5K	39	6G14FDHORX45	269	6G6FJX45S	244
6EFG5KL	59	6G14FDHORX90	270	6G6FJX90L	247
6EFG6K	38	6G14FDLORX	264	6G6FJX90M	246
6FBSPP-6FBSPP	320	6G14MDH	271	6G6FJX90S	245
6FBSPPX-6FBSPPX	319	6G15FDLORX	264	6G6FKX	249
6FBSPPX-6FBSPPX-6FBSPPX	325	6G15FDLORX45	265	6G6FP	274
6FBSPPX-6FBSPPX-6MBSPP	326	6G15FDLORX90	266	6G6FPX	273
6FBSPPX-6FBSPPX90BL	322	6G15FPWX	281	6G6FQLH	283
6FBSPPX-6FBSPPX90SWT	323	6G15MDL	267	6G6FSX	255
6FBSPPX-8FBSPPX	319	6G16DBJ	272	6G6FSX45	256
6FBSPPX-CAP	327	6G18AV	280	6G6FSX90	256
6FJ-CAP	347	6G18DBJ	272	6G6MB	276
6FJ-NUT	348	6G1H	67	6G6MBSPP	241
6FJX-4MBSPPCOR	345	6G2	50	6G6MBSPPBKHD	241
6FJX-4MJ	349	6G22DBJ	272	6G6MBSPT	236

Ref.	P.	Ref.	P.	Ref.	P.
6G6MBX	276	6GS12FDHORX	218	6LOC6FJX	291
6G6MBX45	277	6GS12FDHORX45	218	6LOC6MBSPP	291
6G6MBX90	277	6GS12FDHORX90	219	6LOC6MP	293
6G6MFA	259	6GS12FDLORX	216	6M3K	46
6G6MFFOR	255	6GS12FDLORX90	217	6M3KH	63
6G6MIX	257	6GS12MDH	219	6M4K	45
6G6MIX45	258	6GS12MDL	217	6M4KH	61
6G6MIX90	258	6GS14FDHORX	218	6M4KL	62
6G6MJ	248	6GS14FDHORX45	218	6M5K	44
6G6MP	273	6GS14FDHORX90	219	6MBSPP-10MB	315
6G6MPLN	274	6GS14MDH	219	6MBSPP-10MBSPP	311
6G6MPX	275	6GS1F-4	192	6MBSPP-12FBSPPX	318
6G6MPX90	275	6GS6FBSPORX	193	6MBSPP-12MB	315
6G6MQLH	282	6GS6FBSPORX45	193	6MBSPP-12MBSPP	311
6G6MQLH45	282	6GS6FBSPORX90	194	6MBSPP-12MBSPT	314
6G6MQLH90S	283	6GS6FFORX	199	6MBSPP-12MBSPPWD	312
6G6MS	257	6GS6FFORX45S	200	6MBSPP-12MM	316
6G6PL	280	6GS6FFORX90L	201	6MBSPP-14MM	316
6G7MIX	257	6GS6FFORX90S	200	6MBSPP-16FBSPPX	318
6G7MIX45	258	6GS6FJX	195	6MBSPP-16MBSPP	311
6G7MIX90	258	6GS6FJX45S	196	6MBSPP-16MBSPPWD	312
6G8BSPBJ	242	6GS6FJX90L	197	6MBSPP-16MM	316
6G8BFFFX	242	6GS6FJX90S	196	6MBSPP-18MM	316
6G8FBSPORX	237	6GS6MB	220	6MBSPP-20MM	316
6G8FBSPORX45	238	6GS6MBSPP	194	6MBSPP-22MM	316
6G8FBSPORX90	239	6GS6MFFOR	202	6MBSPP-2MBSPPWD	312
6G8FBSPORX90BL	240	6GS6MJ	198	6MBSPP-4FBSPPX	318
6G8FFORX	250	6GS6MP	220	6MBSPP-4MB	315
6G8FFORX45S	251	6GS8FBSPORX	193	6MBSPP-4MBSPT	314
6G8FFORX90L	254	6GS8FFORX	199	6MBSPP-4MBSPPWD	312
6G8FFORX90M	253	6GS8FFORX45S	200	6MBSPP-6MBSPPBKHD	313
6G8FFORX90S	252	6GS8FFORX90M	201	6MBSPP-6FBSPPX	318
6G8FJX	243	6GS8FJX	195	6MBSPP-6FBSPPX45BL	321
6G8FJX45S	244	6GS8FJX45S	196	6MBSPP-6FBSPPX-6FBSPPX	325
6G8FJX90L	247	6GS8FJX90M	197	6MBSPP-6FBSPPX-6MBSPP	324
6G8FJX90M	246	6GS8FL	202	6MBSPP-6FBSPPX90L	321
6G8FJX90S	245	6GS8FL45M	204	6MBSPP-6FBSPPX90SWT	322
6G8FP	274	6GS8FL90M	206	6MBSPP-6MB	315
6G8FSX	255	6GS8MBSPP	194	6MBSPP-6MBSPP	310
6G8FSX90	256	6GS8MJ	198	6MBSPP-6MBSPP-6FBSPPX	324
6G8MB	276	6GS8MP	220	6MBSPP-6MBSPP-6MBSPP	323
6G8MBSPP	241	6GTH	56	6MBSPP-6MBSPP90BL	320
6G8MBSPT	236	6IA5600	36	6MBSPP-6MBSPT	314
6G8MBX	276	6LOC10FDLX	292	6MBSPP-6MBSPPWD	312
6G8MBX45	277	6LOC10FDLX90	292	6MBSPP-6MP	317
6G8MBX90	277	6LOC10MSP	293	6MBSPP-8FBSPPX	318
6G8MFA	259	6LOC12FDLX	292	6MBSPP-8MB	315
6G8MFFOR	255	6LOC12FDLX90	292	6MBSPP-8MBSPP	311
6G8MJ	248	6LOC12MSP	293	6MBSPP-8MBSPT	314
6G8MP	273	6LOC14DBJ	293	6MBSPP-8MBSPPWD	312
6G8MPX	275	6LOC4MBSPP	291	6MBSPP-PLUG	326
6G8MPX90	275	6LOC6FBSPPX	290	6MEGATECH1000	82
6GS10MJ	198	6LOC6FBSPPX90	290	6MJ-10MB	337

PRODUCT INDEX

INTEGRATED FLUID POWER SOLUTIONS

Ref.	P.	Ref.	P.	Ref.	P.
6MJ-12MB	337	6TH8	52	8G10MJ	248
6MJ-14MMAOR90	330	6TS	348	8G10MS	257
6MJ-14MMCOR	331	6WB-XTFxLL	88	8G12FBFFX	242
6MJ-14MMOR	330	6WTB14FDHORX	287	8G12FBSPORX	237
6MJ-16MMOR	330	6WTB2F-4	286	8G12FDHORX	268
6MJ-18MMCOR	331	6WTB6MP	287	8G12FDLORX	264
6MJ-18MMOR	330	6WTB6FBSPORX-SP	286	8G12FDLORX45	265
6MJ-2MBSPPCOR	332	8C5CXH	81	8G12FDLORX90	266
6MJ-4MB	337	8CM2TDL-XTF	49	8G12FFORX	250
6MJ-4MBA90	338	8EFG4K	40	8G12FFORX45S	251
6MJ-4MBSPPACOR45	335	8EFG4KL	60	8G12FFORX90S	252
6MJ-4MBSPPACOR-6MJ	336	8EFG5K	39	8G12FJX	243
6MJ-4MBSPPACOR90	334	8EFG5KL	59	8G12FJX90S	245
6MJ-4MBSPPCOR	332	8EFG6K	38	8G12FL	259
6MJ-4MBSPPWD	333	8FBSPP-8FBSPP	320	8G12FL45M	261
6MJ-4MJ	340	8FBSPPX-10FBSPPX	319	8G12FL90M	262
6MJ-4MJ90	340	8FBSPPX-12FBSPPX	319	8G12MB	276
6MJ-4MP	346	8FBSPPX-8FBSPPX	319	8G12MBX90	277
6MJ-4MP90	346	8FBSPPX-8FBSPPX-8FBSPPX	325	8G12MDH	271
6MJ-6FJX45	343	8FBSPPX-8FBSPPX-8MBSPP	326	8G12MDL	267
6MJ-6FJX-6MJ	344	8FBSPPX-8FBSPPX90BL	322	8G12MJ	248
6MJ-6FJX90	343	8FBSPPX-8FBSPPX90SWT	323	8G12MP	273
6MJ-6MB	337	8FBSPPX-CAP	327	8G14FDHORX	268
6MJ-6MBA45	338	8FJ-CAP	347	8G14FDHORX45	269
6MJ-6MBA-6MJ	339	8FJ-NUT	348	8G15FDLORX	264
6MJ-6MBA90	338	8FJX-6MBSPPCOR	345	8G15FDLORX45	265
6MJ-6MBSPPACOR45	335	8FJX-6MJ	349	8G15FDLORX90	266
6MJ-6MBSPPACOR90	334	8FJX-8MBSPPCOR	345	8G15MDL	267
6MJ-6MBSPPCOR	332	8FLHCFM	297	8G15MSP	271
6MJ-6MBSPPWD	333	8G1	51	8G16FDHORX	268
6MJ-6MJ	340	8G10FBFFX	242	8G16FDHORX45	269
6MJ-6MJ-4MBSPPACOR	336	8G10FBSPORX	237	8G16FDHORX90	270
6MJ-6MJ-6FJX	344	8G10FBSPORX45	238	8G16MDH	271
6MJ-6MJ-6MBA	339	8G10FBSPORX90	239	8G17FFGX	278
6MJ-6MJ-6MJ	341	8G10FBSPORX90BL	240	8G17FFGX90	279
6MJ-6MJ90	340	8G10FFORX	250	8G17MFG	279
6MJ-6MJBKHD	341	8G10FFORX45S	251	8G18AV	280
6MJ-6MJBKHD45	342	8G10FFORX90L	254	8G18DBJ	272
6MJ-6MJBKHD90	342	8G10FFORX90M	253	8G18FDLORX	264
6MJ-6MP	346	8G10FFORX90S	252	8G18FDLORX45	265
6MJ-6MP90	346	8G10FJX	243	8G18FDLORX90	266
6MJ-8MB	337	8G10FJX45S	244	8G18MDL	267
6MJ-8MBA45	338	8G10FJX90L	247	8G1H	67
6MJ-8MBA90	338	8G10FJX90M	246	8G2	50
6MJ-8MBSPPACOR45	335	8G10FJX90S	245	8G20FDHORX	268
6MJ-8MBSPPACOR90	334	8G10FLK	263	8G22DBJ	272
6MJ-8MBSPPCOR	332	8G10FSX	255	8G2L	66
6MJ-8MBSPPWD	333	8G10MB	276	8G2XH	64
6MJ-8MP	346	8G10MBSPP	241	8G3H	55
6MJ-8MP90	346	8G10MBX	276	8G6FBSPORX	237
6MJ-PLUG	347	8G10MBX90	277	8G6FFORX	250
6TH7	53	8G10MFA	259	8G6FFORX45S	251
6TH7DL	54	8G10MFFOR	255	8G6FFORX90S	252

Ref.	P.	Ref.	P.	Ref.	P.
8G6FJX	243	8G8MS	257	8GS8FKX	198
8G6FJX90S	245	8G8PL	280	8GS8FL	202
8G6FP	274	8GS10FBSPORX	193	8GS8FL22M	203
8G6MBSPP	241	8GS10FFORX	199	8GS8FL45M	204
8G6MBSPT	236	8GS10FFORX45S	200	8GS8FL60M	204
8G6MP	273	8GS10FFORX90M	201	8GS8FL90M	206
8G6MPX	275	8GS10FJX	195	8GS8FLH	207
8G6MPX90	275	8GS10FJX45S	196	8GS8FLH45M	209
8G8BSPBJ	242	8GS10FJX90L	197	8GS8FLH90M	210
8G8FBFFX	242	8GS10FJX90M	197	8GS8HLE	224
8G8FBSPORX	237	8GS10FJX90S	196	8GS8HLE90-86	224
8G8FBSPORX45	238	8GS10FLK	211	8GS8MB	220
8G8FBSPORX90	239	8GS10MB	220	8GS8MBSPP	194
8G8FBSPORX90BL	240	8GS10MJ	198	8GS8MFFOR	202
8G8FFORX	250	8GS12FFORX	199	8GS8MJ	198
8G8FFORX45S	251	8GS12FFORX90S	200	8GS8MP	220
8G8FFORX90L	254	8GS12FJX	195	8GTH	56
8G8FFORX90M	253	8GS12FJX90S	196	8LOC15FDLX	292
8G8FFORX90S	252	8GS12FL	202	8LOC15FDLX90	292
8G8FJJSX	249	8GS12FL45M	204	8LOC15MSP	293
8G8FJX	243	8GS12FL90M	206	8LOC8FBSPPPX	290
8G8FJX45S	244	8GS12FLH	207	8LOC8FBSPPPX90	290
8G8FJX90L	247	8GS12FLH45M	209	8LOC8FJX	291
8G8FJX90M	246	8GS12FLH90M	210	8LOC8MBSPP	291
8G8FJX90S	245	8GS12MP	220	8LOC8MP	293
8G8FKX	249	8GS14FDHORX	218	8M3K	46
8G8FL	259	8GS15FDLORX	216	8M3KH	63
8G8FL45M	261	8GS15FDLORX45	216	8M4K	45
8G8FL90M	262	8GS15FDLORX90	217	8M4KH	61
8G8FP	274	8GS15MDL	217	8M4KL	62
8G8FPX	273	8GS16FDHORX	218	8M5K	44
8G8FQLH	283	8GS16FDHORX45	218	8MBSPP-10FBSPPX	318
8G8FSX	255	8GS16FDHORX90	219	8MBSPP-10MB	315
8G8FSX45	256	8GS16MDH	219	8MBSPP-10MBSPP	311
8G8FSX90	256	8GS17FFGX	221	8MBSPP-12FBSPPX	318
8G8MB	276	8GS17FFGX90	221	8MBSPP-12MB	315
8G8MBSPP	241	8GS17FPFL	222	8MBSPP-12MBSPP	311
8G8MBSPPBKHD	241	8GS17MFG	221	8MBSPP-12MBSPT	314
8G8MBSPT	236	8GS17MPFL	222	8MBSPP-12MBSPPWD	312
8G8MBX	276	8GS1F-4	192	8MBSPP-12MM	316
8G8MBX45	277	8GS20FDHORX	218	8MBSPP-14MM	316
8G8MBX90	277	8GS8FBSPORX	193	8MBSPP-16FBSPPX	318
8G8MFA	259	8GS8FBSPORX45	193	8MBSPP-16MBSPP	311
8G8MFFOR	255	8GS8FBSPORX90	194	8MBSPP-16MBSPPWD	312
8G8MIX	257	8GS8FFORX	199	8MBSPP-16MM	316
8G8MIX90	258	8GS8FFORX45S	200	8MBSPP-18MM	316
8G8MJ	248	8GS8FFORX90-83	201	8MBSPP-20MBSPP	311
8G8MP	273	8GS8FFORX90S	200	8MBSPP-20MM	316
8G8MPX	275	8GS8FJX	195	8MBSPP-22MM	316
8G8MPX90	275	8GS8FJX45S	196	8MBSPP-24MM	316
8G8MQLH	282	8GS8FJX90L	197	8MBSPP-26MM	316
8G8MQLH45	282	8GS8FJX90M	197	8MBSPP-4FBSPPX	318
8G8MQLH90S	283	8GS8FJX90S	196	8MBSPP-4MBSPT	314

PRODUCT INDEX

INTEGRATED FLUID POWER SOLUTIONS

Ref.	P.	Ref.	P.	Ref.	P.
8MBSPP-4MBSPPWD	312	8MJ-8MBA90	338	10G1	51
8MBSPP-6FBSPPX	318	8MJ-8MBSPPACOR45	335	10G10FBSPORX	237
8MBSPP-6MBSPT	314	8MJ-8MBSPPACOR90	334	10G10FBSPORX45	238
8MBSPP-6MBSPPWD	312	8MJ-8MBSPPCOR	332	10G10FBSPORX90	239
8MBSPP-8MBSPPBKHD	313	8MJ-8MBSPPWD	333	10G10FBSPORX90BL	240
8MBSPP-8FBSPPX	318	8MJ-8MJ	340	10G10FFORX	250
8MBSPP-8FBSPPX45BL	321	8MJ-8MJ-6MBSPPACOR	336	10G10FFORX45S	251
8MBSPP-8FBSPPX-8FBSPPX	325	8MJ-8MJ-8FJX	344	10G10FFORX90L	254
8MBSPP-8FBSPPX-8MBSPP	324	8MJ-8MJ-8MBA	339	10G10FFORX90M	253
8MBSPP-8FBSPPX90BL	321	8MJ-8MJ-8MBSPPACOR	336	10G10FFORX90S	252
8MBSPP-8FBSPPX90SWT	322	8MJ-8MJ-8MJ	341	10G10FJX	243
8MBSPP-8MB	315	8MJ-8MJ90	340	10G10FJX45S	244
8MBSPP-8MBSPP	310	8MJ-8MJBKHD	341	10G10FJX90-036	245
8MBSPP-8MBSPP-8FBSPPX	324	8MJ-8MJBKHD45	342	10G10FJX90L	247
8MBSPP-8MBSPP-8MBSPP	323	8MJ-8MJBKHD90	342	10G10FJX90M	246
8MBSPP-8MBSPP90BL	320	8MJ-8MP	346	10G10FKX	249
8MBSPP-8MBSPT	314	8MJ-8MP90	346	10G10FLK	263
8MBSPP-8MBSPPWD	312	8MJ-PLUG	347	10G10FLK45	263
8MBSPP-8MP	317	8PA-FL	296	10G10FLK90	263
8MBSPP-PLUG	326	8PH-FLH	296	10G10FQLH	283
8MEGATECH1000	82	8TH7	53	10G10MB	276
8MJ-10MB	337	8TH7DL	54	10G10MBSPP	241
8MJ-10MBA45	338	8TH8	52	10G10MBSPPBKHD	241
8MJ-10MBA90	338	8TS	348	10G10MBSPT	236
8MJ-12MB	337	8WB-XTFxLL	88	10G10MBX90	277
8MJ-12MBSPPACOR90	334	8WTB16FDHORX	287	10G10MFFOR	255
8MJ-12MBSPPCOR	332	8WTB2F-4	286	10G10MIX	257
8MJ-12MBSPPWD	333	8WTB8FBSPORX-SP	286	10G10MJ	248
8MJ-12MP	346	8WTB8MP	287	10G10MQLH	282
8MJ-16MBSPPCOR	332	10C5CXH	81	10G10MQLH45	282
8MJ-16MBSPPWD	333	10EFG4K	40	10G10MQLH90S	283
8MJ-16MMOR	330	10EFG5K	39	10G12FBFFX	242
8MJ-18MMAOR90	330	10EFG5KL	59	10G12FBSPORX	237
8MJ-18MMOR	330	10EFG6K	38	10G12FBSPORX45	238
8MJ-MBSPPACOR90	334	10FBSPP-10FBSPP	320	10G12FBSPORX90	239
8MJ-4MBSPPCOR	332	10FBSPPX-10FBSPPX	319	10G12FFORX	250
8MJ-4MBSPPWD	333	10FBSPPX-10FBSPPX-10FBSPPX	325	10G12FFORX45S	251
8MJ-6MB	337	10FBSPPX-10FBSPPX-10MBSPP	326	10G12FFORX90S	252
8MJ-6MBA45	338	10FBSPPX-10FBSPPX90BL	322	10G12FJX	243
8MJ-6MBSPPACOR45	335	10FBSPPX-10FBSPPX90SWT	323	10G12FJX45S	244
8MJ-6MBSPPACOR-8MJ	336	10FBSPPX-CAP	327	10G12FJX90L	247
8MJ-6MBSPPACOR90	334	10FJ-CAP	347	10G12FJX90M	246
8MJ-6MBSPPCOR	332	10FJ-NUT	348	10G12FJX90S	245
8MJ-6MBSPPWD	333	10FJX-4MJ	349	10G12FL	259
8MJ-6MJ	340	10FJX-6MJ	349	10G12FL90M	262
8MJ-6MJ90	340	10FJX-8MBSPPCOR	345	10G12MB	276
8MJ-6MP	346	10FJX-8MJ	349	10G12MBSPP	241
8MJ-8FJX45	343	10FQLH-10MB	353	10G12MFFOR	255
8MJ-8FJX-8MJ	344	10FQLH-12MB	353	10G12MJ	248
8MJ-8FJX90	343	10FQLH-12MBSPPCSC	352	10G12MP	273
8MJ-8MB	337	10FQLH-22MMOR	353	10G12MPX	275
8MJ-8MBA45	338	10FQLH-8MB	353	10G14FJX	243
8MJ-8MBA-8MJ	339	10FQLH-8MBSPPCSC	352	10G16FDHORX	268

Ref.	P.	Ref.	P.	Ref.	P.
10G18FDLORX	264	10GS12FL45M	204	10MJ-10FJX45	343
10G18FDLORX45	265	10GS12FL90-100	207	10MJ-10FJX90	343
10G18FDLORX90	266	10GS12FL90M	206	10MJ-10MB	337
10G18MDL	267	10GS12FLH	207	10MJ-10MBA-10MJ	339
10G18MSP	271	10GS12FLH45M	209	10MJ-10MBA45	338
10G1H	67	10GS12FLH90M	210	10MJ-10MBA90	338
10G2	50	10GS12MB	220	10MJ-10MJ	340
10G20FDHORX	268	10GS12MBSPP	194	10MJ-10MJ-10FJX	344
10G20FDHORX45	269	10GS12MJ	198	10MJ-10MJ-10MBA	339
10G20FDHORX90	270	10GS12MP	220	10MJ-10MJ-10MJ	341
10G20MDH	271	10GS18FDLORX	216	10MJ-10MJ-8MBSPPACOR	336
10G21FFGX	278	10GS18FDLORX90	217	10MJ-10MJ90	340
10G21FFGX90	279	10GS18MDL	217	10MJ-10MJBKHD	341
10G21MFG	279	10GS1F-4	192	10MJ-10MJBKHD45	342
10G22DBJ	272	10GS20FDH0RX	218	10MJ-10MJBKHD90	342
10G2L	66	10GS20FDH0RX45	218	10MJ-12MB	337
10G2XH	64	10GS20FDH0RX90	219	10MJ-12MBA90	338
10G3H	55	10GS20MDH	219	10MJ-12MBSPPACOR45	335
10G8FFORX	250	10GS21FFGX	221	10MJ-12MBSPPACOR90	334
10G8FFORX45S	251	10GS21FFGX90	221	10MJ-12MBSPPCOR	332
10G8FFORX90L	254	10GS21FPFL	222	10MJ-12MBSPPWD	333
10G8FFORX90S	252	10GS21MFG	221	10MJ-12MP	346
10G8FJX	243	10GS21MPFL	222	10MJ-14MMOR	330
10G8MB	276	10GS21MPFL90	223	10MJ-18MMAOR90	330
10G8MJ	248	10GS25FDH0RX	218	10MJ-18MMOR	330
10G8MP	273	10GS8FLH	207	10MJ-22MMAOR90	330
10GS10FBSPORX	193	10GS8FLH45M	209	10MJ-22MMOR	330
10GS10FBSPORX45	193	10GS8FLH90M	210	10MJ-6MBSPPACOR90	334
10GS10FBSPORX90	194	10GS8MP	220	10MJ-6MBSPPCOR	332
10GS10FFORX	199	10GTH	56	10MJ-6MBSPPWD	333
10GS10FFORX45S	200	10HD-UHP	42	10MJ-6MP	346
10GS10FFORX90L	201	10LOC10FJX	291	10MJ-8MB	337
10GS10FFORX90M	201	10LOC18FDLX	292	10MJ-8MBA45	338
10GS10FFORX90S	200	10LOC18FDLX90	292	10MJ-8MBSPPACOR-10MJ	336
10GS10FJX	195	10LOC18MSP	293	10MJ-8MBSPPACOR45	335
10GS10FJX45-018	196	10M3K	46	10MJ-8MBSPPACOR90	334
10GS10FJX90-036	196	10M3KH	63	10MJ-8MBSPPCOR	332
10GS10FJX90M	197	10M4K	45	10MJ-8MBSPPWD	333
10GS10FKX	198	10M4KH	61	10MJ-8MJ	340
10GS10FLK	211	10M4KL	62	10MJ-8MJ90	340
10GS10FLK45-026	211	10MBSPP-10MBSPPBKHD	313	10MJ-8MP	346
10GS10FLK90-055	212	10MBSPP-10FBSPPX	318	10MJ-8MP90	346
10GS10MB	220	10MBSPP-10FBSPPX90BL	321	10MJ-PLUG	347
10GS10MBSPP	194	10MBSPP-10FBSPPX90SWT	322	10TS	348
10GS10MJ	198	10MBSPP-10MB	315	12C5CXH	81
10GS12FBSPORX	193	10MBSPP-10MBSPP	310	12EFG4K	40
10GS12FBSPORX45	193	10MBSPP-10MBSPP-10MBSPP	323	12EFG4KL	60
10GS12FBSPORX90	194	10MBSPP-12MB	315	12EFG5K	39
10GS12FFORX	199	10MBSPP-12MBSPP	311	12EFG5KL	59
10GS12FJX	195	10MBSPP-16MBSPP	311	12EFG6K	38
10GS12FJX45S	196	10MBSPP-PLUG	326	12EFG6KL	58
10GS12FJX90M	197	10MEGATECH1000	82	12FBSP-12FBSP	320
10GS12FL	202	10MJ-10FJX-10MJ	344	12FBSP-12FBSPPX	319

PRODUCT INDEX

INTEGRATED FLUID POWER SOLUTIONS

Ref.	P.	Ref.	P.	Ref.	P.
12FBSPPX-12FBSPPX-12FBSPPX	325	12G12FPX	273	12G22FDLORX	264
12FBSPPX-12FBSPPX-12MBSPP	326	12G12FQLH	283	12G22FDLORX45	265
12FBSPPX-12FBSPPX90BL	322	12G12FSX	255	12G22FDLORX90	266
12FBSPPX-12FBSPPX90SWT	323	12G12FSX45	256	12G22MDL	267
12FBSPPX-16FBSPPX	319	12G12FSX90	256	12G22MSP	271
12FBSPPX-CAP	327	12G12MB	276	12G25FDHORX	268
12FJ-CAP	347	12G12MBSPP	241	12G25FDHORX45	269
12FJ-NUT	348	12G12MBSPPBKHD	241	12G25FDHORX90	270
12FJX-10MJ	349	12G12MBSPT	236	12G25MDH	271
12FJX-12MBSPPCOR	345	12G12MBX	276	12G26DBJ	272
12FJX-4MJ	349	12G12MBX90	277	12G27FFGX	278
12FJX-8MJ	349	12G12MFA	259	12G27FFGX90	279
12FLHCFM	297	12G12MFFOR	255	12G27MFG	279
12FQLH-10MB	353	12G12MJ	248	12G2L	66
12FQLH-12MB	353	12G12MP	273	12G2XH	64
12FQLH-12MBSPPBKHD	352	12G12MPX	275	12G3H	55
12FQLH-12MBSPPCSC	352	12G12MPX90	275	12G8MP	273
12FQLH-16MB	353	12G12MQLH	282	12G8MPX	275
12FQLH-16MBSPPCSC	352	12G12MQLH45	282	12GMV	57
12FQLH-26MMOR	353	12G12MQLH90S	283	12GS10FFORX	199
12FQLH-27MMOR	353	12G12MS	257	12GS10FFORX90S	200
12FQLH-8MBSPPCSC	352	12G12PL	280	12GS10FJX	195
12G1	51	12G14FJX	243	12GS10FLK	211
12G10FFORX	250	12G14FJX90-054	245	12GS10FLK90-055	212
12G10FFORX45S	251	12G14FJX90-100	247	12GS12FBSPORX	193
12G10FFORX90S	252	12G14MB	276	12GS12FBSPORX45	193
12G10FJX	243	12G14MJ	248	12GS12FBSPORX90	194
12G10FJX45S	244	12G16FBSPORX	237	12GS12FFORX	199
12G10FJX90M	246	12G16FBSPORX90	239	12GS12FFORX45S	200
12G12BSPBJ	242	12G16FFORX	250	12GS12FFORX90L	201
12G12FBFFX	242	12G16FFORX45S	251	12GS12FFORX90M	201
12G12FBSPORX	237	12G16FFORX90S	252	12GS12FFORX90S	200
12G12FBSPORX45	238	12G16FJX	243	12GS12FJX	195
12G12FBSPORX90	239	12G16FJX45S	244	12GS12FJX45S	196
12G12FBSPORX90BL	240	12G16FJX90S	245	12GS12FJX90L	197
12G12FFORX	250	12G16FL	259	12GS12FJX90M	197
12G12FFORX45S	251	12G16FL45S	261	12GS12FJX90S	196
12G12FFORX90L	254	12G16FL60M	261	12GS12FKX	198
12G12FFORX90M	253	12G16FL90S	262	12GS12FL	202
12G12FFORX90S	252	12G16MB	276	12GS12FL22M	203
12G12FJISX	249	12G16MFFOR	255	12GS12FL30M	203
12G12FJX	243	12G16MJ	248	12GS12FL45M	204
12G12FJX45S	244	12G16MP	273	12GS12FL60M	204
12G12FJX90L	247	12G18FDLORX	264	12GS12FL90-100	207
12G12FJX90M	246	12G18FDLORX90	266	12GS12FL90-125	207
12G12FJX90S	245	12G18MDL	267	12GS12FL90-150	207
12G12FKX	249	12G1H	67	12GS12FL90M	206
12G12FL	259	12G2	50	12GS12FLC	212
12G12FL22M	260	12G20FDHORX	268	12GS12FLC22-016	213
12G12FL45M	261	12G20FDHORX45	269	12GS12FLC30-022	213
12G12FL60M	261	12G20FDHORX90	270	12GS12FLC45-035	214
12G12FL90-054	262	12G20MDH	271	12GS12FLC90-068	215
12G12FP	274	12G22DBJ	272	12GS12FLC90-128	215

Ref.	P.	Ref.	P.	Ref.	P.
12GS12FLH	207	12GS22FDLORX	216	12MBSPP-16MB	315
12GS12FLH45M	209	12GS22FDLORX45	216	12MBSPP-16MBSPP	311
12GS12FLH60M	209	12GS22FDLORX90	217	12MBSPP-16MBSPT	314
12GS12FLH90-100	211	12GS22MDL	217	12MBSPP-16MBSPPWD	312
12GS12FLH90M	210	12GS22MKB	223	12MBSPP-18MM	316
12GS12HLE	224	12GS25FDH0RX	218	12MBSPP-20FBSPPX	318
12GS12HLE90-129	224	12GS25FDH0RX45	218	12MBSPP-20MBSPP	311
12GS12MB	220	12GS25FDH0RX90	219	12MBSPP-20MBSPT	314
12GS12MBSPP	194	12GS25MDH	219	12MBSPP-22MM	316
12GS12MFFOR	202	12GS27FFGX	221	12MBSPP-26MM	316
12GS12MJ	198	12GS27FPFL	222	12MBSPP-4MBSPPWD	312
12GS12MP	220	12GS27MFG	221	12MBSPP-6FBSPPX	318
12GS14FJX	195	12GS27MPFL	222	12MBSPP-6MBSPPWD	312
12GS14FJX90-060	197	12GS27MPFL90	223	12MBSPP-8FBSPPX	318
12GS14MJ	198	12GS28FDLORX	216	12MBSPP-8MB	315
12GS16FBSPORX	193	12GS28MKB	223	12MBSPP-8MBSPT	314
12GS16FFORX	199	12GS30FDH0RX	218	12MBSPP-8MBSPPWD	312
12GS16FFORX45S	200	12GS30MDH	219	12MBSPP-PLUG	326
12GS16FFORX90S	200	12GS8FL	202	12MEGATECH1000	82
12GS16FJX	195	12GS8FL90-050	206	12MJ-12FJX-12MJ	344
12GS16FJX45S	196	12GTH	56	12MJ-12FJX45	343
12GS16FJX90M	197	12HD-UHP	42	12MJ-12FJX90	343
12GS16FJX90S	196	12ID5K	37	12MJ-12MB	337
12GS16FL	202	12LOC12FBSPPX	290	12MJ-12MBA-12MJ	339
12GS16FL22M	203	12LOC12FBSPPX90	290	12MJ-12MBA45	338
12GS16FL30M	203	12LOC12FJX	291	12MJ-12MBA90	338
12GS16FL45S	204	12LOC12MBSPP	291	12MJ-12MBSPPACOR-12MJ	336
12GS16FL60M	204	12LOC12MP	293	12MJ-12MBSPPACOR45	335
12GS16FL67M	205	12LOC22FDLX	292	12MJ-12MBSPPACOR90	334
12GS16FL90-100	207	12LOC22FDLX90	292	12MJ-12MBSPPCOR	332
12GS16FL90M	206	12LOC22MSP	293	12MJ-12MBSPPWD	333
12GS16FL90S	205	12M3K	46	12MJ-12MJ	340
12GS16FLC	212	12M3KH	63	12MJ-12MJ-12FJX	344
12GS16FLC30-022	213	12M4K	45	12MJ-12MJ-12MBA	339
12GS16FLC45-035	214	12M4KH	61	12MJ-12MJ-12MBSPPACOR	336
12GS16FLC60-048	214	12M4KL	62	12MJ-12MJ-12MJ	341
12GS16FLC90-068	215	12MBSPP-10MB	315	12MJ-12MJ90	340
12GS16FLH	207	12MBSPP-12MBSPPBKHD	313	12MJ-12MJJBKHD	341
12GS16FLH45M	209	12MBSPP-12FBSPPX	318	12MJ-12MJJBKHD45	342
12GS16FLH60M	209	12MBSPP-12FBSPPX-12FBSPPX	325	12MJ-12MJJBKHD90	342
12GS16FLH90M	210	12MBSPP-12FBSPPX-12MBSPP	324	12MJ-12MP	346
12GS16MB	220	12MBSPP-12FBSPPX45BL	321	12MJ-12MP90	346
12GS16MBSPP	194	12MBSPP-12FBSPPX90BL	321	12MJ-16MBSPPACOR90	334
12GS16MFFOR	202	12MBSPP-12FBSPPX90SWT	322	12MJ-16MBSPPWD	333
12GS16MJ	198	12MBSPP-12MB	315	12MJ-22MMAOR90	330
12GS16MP	220	12MBSPP-12MBSPP	310	12MJ-22MMOR	330
12GS1F-4	192	12MBSPP-12MBSPP-12FBSPPX	324	12MJ-27MMAOR90	330
12GS20FDH0RX	218	12MBSPP-12MBSPP-12MBSPP	323	12MJ-27MMOR	330
12GS20FDH0RX45	218	12MBSPP-12MBSPP90BL	320	12MJ-8MB	337
12GS20FDH0RX90	219	12MBSPP-12MBSPT	314	12MJ-8MBSPPACOR90	334
12GS20FFORX	199	12MBSPP-12MBSPPWD	312	12MJ-8MBSPPWD	333
12GS20FL	202	12MBSPP-12MP	317	12MJ-PLUG	347
12GS20MDH	219	12MBSPP-16FBSPPX	318	12PA-FL	296

PRODUCT INDEX

INTEGRATED FLUID POWER SOLUTIONS

Ref.	P.	Ref.	P.	Ref.	P.
12PH-FLH	296	16G16FBSPORX90BL	240	16G28MDL	267
12TH7	53	16G16FFORX	250	16G2L	66
12TH8	52	16G16FFORX45S	251	16G2XH	64
12TS	348	16G16FFORX90L	254	16G30DBJ	272
12WB-XTFxLL	88	16G16FFORX90M	253	16G30FDHORX	268
12WTB12FBSPORX-SP	286	16G16FFORX90S	252	16G30FDHORX45	269
12WTB12MP	287	16G16FJISX	249	16G30FDHORX90	270
12WTB25FDHORX	287	16G16FJX	243	16G30MDH	271
12WTB2F-1	286	16G16FJX45S	196	16G34FFGX	278
14LG5K	566	16G16FJX45S	244	16G34MFG	279
14MJ-14FJX-14MJ	344	16G16FJX90L	247	16G3H	55
14MJ-14FJX90	343	16G16FJX90M	246	16GMV	57
16C5CXH	81	16G16FJX90S	245	16GS12FJX	195
16EFG4K	40	16G16FKX	249	16GS12FLH	207
16EFG4KL	60	16G16FL	259	16GS12FLH45M	209
16EFG5K	39	16G16FL22M	260	16GS12FLH90M	210
16EFG5KL	59	16G16FL30M	260	16GS12MP	220
16EFG6K	38	16G16FL45S	261	16GS14FJX	195
16EFG6KL	58	16G16FL90S	262	16GS16FBSPORX	193
16FBSPP-16FBSPP	320	16G16FPX	273	16GS16FBSPORX45	193
16FBSPPX-16FBSPPX	319	16G16FQLH	283	16GS16FBSPORX90	194
16FBSPPX-16FBSPPX-16FBSPPX	325	16G16MB	276	16GS16FFORX	199
16FBSPPX-16FBSPPX-16MBSPP	326	16G16MBSPP	241	16GS16FFORX45S	200
16FBSPPX-16FBSPPX90BL	322	16G16MBSPPBKHD	241	16GS16FFORX90L	201
16FBSPPX-16FBSPPX90SWT	323	16G16MBSPT	236	16GS16FFORX90M	201
16FBSPPX-CAP	327	16G16MFA	259	16GS16FFORX90S	200
16FJ-CAP	347	16G16MFFOR	255	16GS16FJX	195
16FJ-NUT	348	16G16MJ	248	16GS16FJX45S	196
16FJX-10MJ	349	16G16MP	273	16GS16FJX90L	197
16FJX-12MJ	349	16G16MPX	275	16GS16FJX90M	197
16FJX-16MBSPPCOR	345	16G16MQLH	282	16GS16FJX90S	196
16FJX-6MJ	349	16G16MQLH45	282	16GS16FKX	198
16FLHCFM	297	16G16MQLH90S	283	16GS16FL	202
16FQLH-12MBSPPCSC	352	16G1H	67	16GS16FL22M	203
16FQLH-16MB	353	16G2	50	16GS16FL30M	203
16FQLH-16MBSPPBKHD	352	16G20FFORX	250	16GS16FL45M	204
16FQLH-16MBSPPCSC	352	16G20FFORX90M	253	16GS16FL60M	204
16FQLH-33MMOR	353	16G20FJX	243	16GS16FL67M	205
16G1	51	16G20FJX90S	245	16GS16FL90-100	207
16G12FBSPORX	237	16G20FL	259	16GS16FL90-120	207
16G12FBSPORX90	239	16G20FL45S	261	16GS16FL90M	206
16G12FBSPORX90BL	240	16G20FL90S	262	16GS16FL90S	205
16G12FFORX45S	251	16G20MFFOR	255	16GS16FLC	212
16G12FFORX90S	252	16G20MJ	248	16GS16FLC22-017	213
16G12FJX	243	16G24FL	259	16GS16FLC30-023	213
16G12FL	259	16G24FL90	262	16GS16FLC45-037	214
16G12FL45M	261	16G25FDHORX	268	16GS16FLC60-050	214
16G12MP	273	16G25FDHORX45	269	16GS16FLC67-057	215
16G14FJX	243	16G25FDHORX90	270	16GS16FLC90-074	215
16G14MB	276	16G25MDH	271	16GS16FLC90-132	215
16G16FBSPORX	237	16G28FDLORX	264	16GS16FLH	207
16G16FBSPORX45	238	16G28FDLORX45	265	16GS16FLH22M	208
16G16FBSPORX90	239	16G28FDLORX90	266	16GS16FLH30M	208

Ref.	P.	Ref.	P.	Ref.	P.
16GS16FLH45M	209	16GS28FDLORX90	217	16MJ-12MBSPPWD	333
16GS16FLH60M	209	16GS28MDL	217	16MJ-16FJX-16MJ	344
16GS16FLH90-100	211	16GS28MKB	223	16MJ-16FJX45	343
16GS16FLH90-120	211	16GS30FDHORX	218	16MJ-16FJX90	343
16GS16FLH90M	210	16GS30FDHORX45	218	16MJ-16MB	337
16GS16FLH90S	210	16GS30FDHORX90	219	16MJ-16MBA-16MJ	339
16GS16HLE	224	16GS30MDH	219	16MJ-16MBA45	338
16GS16HLE90-127	224	16GS34FFGX	221	16MJ-16MBA90	338
16GS16MB	220	16GS34FPFL	222	16MJ-16MBSPPACOR-16MJ	336
16GS16MBSPP	194	16GS34MFG	221	16MJ-16MBSPPACOR45	335
16GS16MFFOR	202	16GS34MPFL	222	16MJ-16MBSPPACOR90	334
16GS16MJ	198	16GS34MPFL90	223	16MJ-16MBSPPCOR	332
16GS16MP	220	16GS35MKB	223	16MJ-16MBSPPWD	333
16GS1F-4	193	16GTH	56	16MJ-16MJ	340
16GS20FBSPORX	193	16HD-UHP	42	16MJ-16MJ-16FJX	344
16GS20FFORX	199	16ID5K	37	16MJ-16MJ-16MBA	339
16GS20FFORX45S	200	16LG5K	566	16MJ-16MJ-16MBSPPACOR	336
16GS20FFORX90M	201	16M3K	46	16MJ-16MJ-16MJ	341
16GS20FFORX90S	200	16M3KH	63	16MJ-16MJ90	340
16GS20FJX	195	16MBSPP-12FBSPPX	318	16MJ-16MJJBKHD	341
16GS20FJX45S	196	16MBSPP-12MB	315	16MJ-16MJJBKHD45	342
16GS20FJX90L	197	16MBSPP-12MBSPT	314	16MJ-16MJJBKHD90	342
16GS20FL	202	16MBSPP-12MBSPPWD	312	16MJ-16MP	346
16GS20FL22M	203	16MBSPP-16MBSPPBKHD	313	16MJ-16MP90	346
16GS20FL30M	203	16MBSPP-16FBSPPX	318	16MJ-20MB	337
16GS20FL45M	204	16MBSPP-16FBSPPX-16FBSPPX	325	16MJ-20MBSPPCOR	332
16GS20FL60M	204	16MBSPP-16FBSPPX-16MBSPP	324	16MJ-20MBSPPWD	333
16GS20FL67M	205	16MBSPP-16FBSPPX45BL	321	16MJ-PLUG	347
16GS20FL90M	206	16MBSPP-16FBSPPX90BL	321	16PA-FL	296
16GS20FL90S	205	16MBSPP-16FBSPPX90SWT	322	16PH-FLH	296
16GS20FLC	212	16MBSPP-16MB	315	16TH7	53
16GS20FLC22-017	213	16MBSPP-16MBSPP	310	16TH8	52
16GS20FLC30-023	213	16MBSPP-16MBSPP-16FBSPPX	324	16TS	348
16GS20FLC45-037	214	16MBSPP-16MBSPP-16MBSPP	323	1JC04	90
16GS20FLC60-050	214	16MBSPP-16MBSPP90BL	320	1JC05	90
16GS20FLC67-057	215	16MBSPP-16MBSPT	314	1JC05B	90
16GS20FLC90-074	215	16MBSPP-16MBSPPWD	312	1JC06	90
16GS20FLH	207	16MBSPP-16MP	317	1JC06B	90
16GS20FLH30M	208	16MBSPP-20FBSPPX	318	1JC06G	90
16GS20FLH45M	209	16MBSPP-20MBSPP	311	1JC08B	90
16GS20FLH90M	210	16MBSPP-20MBSPT	314	1JC08G	90
16GS20FLH90S	210	16MBSPP-22MM	316	20C5CXH	81
16GS20MJ	198	16MBSPP-24FBSPPX	318	20EFG3K	41
16GS20MP	220	16MBSPP-24MBSPP	311	20EFG4K	40
16GS24FL	202	16MBSPP-26MM	316	20EFG4KL	60
16GS24FL90S	205	16MBSPP-32MBSPP	311	20EFG5K	39
16GS24FLH90S	210	16MBSPP-8FBSPPX	318	20EFG5KL	59
16GS25FDHORX	218	16MBSPP-8MBSPPWD	312	20EFG6K	38
16GS25FDHORX45	218	16MBSPP-PLUG	326	20FBSP-20FBSP	320
16GS25FDHORX90	219	16MEGATECH1000	82	20FBSPPX-20FBSPPX	319
16GS25MDH	219	16MJ-12MB	337	20FBSPPX-20FBSPPX-20FBSPPX	325
16GS28FDLORX	216	16MJ-12MBSPPACOR90	334	20FBSPPX-20FBSPPX90BL	322
16GS28FDLORX45	216	16MJ-12MBSPPCOR	332	20FBSPPX-20FBSPPX90SWT	323

PRODUCT INDEX

INTEGRATED FLUID POWER SOLUTIONS

Ref.	P.	Ref.	P.	Ref.	P.
20FBSPPX-CAP	327	20GS16FLH	207	20GS24FL22M	203
20FJ-NUT	348	20GS16FLH45-034	209	20GS24FL30M	203
20FJX-20MBSPPCOR	345	20GS16FLH90-100	211	20GS24FL45S	204
20FLHCFM	297	20GS16FLH90M	210	20GS24FL60M	204
20G1	51	20GS16FLH90S	210	20GS24FL90-118	206
20G16FL90S	262	20GS1F-4	192	20GS24FL90S	205
20G16MBSPP	241	20GS1F-6	192	20GS24FLC	212
20G1H	67	20GS20FBSPORX	193	20GS24FLC22-017	213
20G2	50	20GS20FBSPORX45	193	20GS24FLC30-024	213
20G20FBSPORX	237	20GS20FBSPORX90	194	20GS24FLC45-037	214
20G20FBSPORX45	238	20GS20FFORX	199	20GS24FLC60-052	214
20G20FBSPORX90	239	20GS20FFORX45-032	200	20GS24FLC67-059	215
20G20FFORX	250	20GS20FFORX90L	201	20GS24FLC90-077	215
20G20FFORX45S	251	20GS20FFORX90M	201	20GS24FLH	207
20G20FFORX90L	254	20GS20FFORX90S	200	20GS24FLH30M	208
20G20FFORX90M	253	20GS20FJX	195	20GS24FLH45M	209
20G20FFORX90S	252	20GS20FJX45-038	196	20GS24FLH90-150	211
20G20FJX	243	20GS20FJX90L	197	20GS24FLH90S	210
20G20FJX45-035	244	20GS20FJX90M	197	20GS35FDLORX	216
20G20FJX90L	247	20GS20FJX90S	196	20GS38FDHORX	218
20G20FJX90M	246	20GS20FL	202	20GS38FDHORX45	218
20G20FKX	249	20GS20FL22M	203	20GS38FDHORX90	219
20G20FL	259	20GS20FL30M	203	20GS38MDH	219
20G20FL22M	260	20GS20FL45S	204	20GS42FPFL	222
20G20FL45S	261	20GS20FL60M	204	20GS42MPFL	222
20G20FL90S	262	20GS20FL67M	205	20GS42MPFL90	223
20G20MB	276	20GS20FL90-168	207	20HD-UHP	42
20G20MBSPP	241	20GS20FL90M	206	20LG5K	566
20G20MFFOR	255	20GS20FL90S	205	20M2T	48
20G20MJ	248	20GS20FLC	212	20MBSPP-12FBSPPX	318
20G20MP	273	20GS20FLC22-017	213	20MBSPP-12MBSPT	314
20G24FJX	243	20GS20FLC30-024	213	20MBSPP-12MBSPPWD	312
20G24FL	259	20GS20FLC45-037	214	20MBSPP-16FBSPPX	318
20G24FL90S	262	20GS20FLC60-052	214	20MBSPP-16MBSPT	314
20G2H	65	20GS20FLC67-059	215	20MBSPP-20MBSPPBKHD	313
20G2L	66	20GS20FLC90-077	215	20MBSPP-20FBSPPX	318
20G2XH	64	20GS20FLH	207	20MBSPP-20FBSPPX-20MBSPP	324
20G35FDLORX	264	20GS20FLH22M	208	20MBSPP-20FBSPPX90BL	321
20G35FDLORX45	265	20GS20FLH30M	208	20MBSPP-20FBSPPX90BL	322
20G35FDLORX90	266	20GS20FLH45M	209	20MBSPP-20MBSPP	310
20G35MDL	267	20GS20FLH60M	209	20MBSPP-20MBSPP-20FBSPPX	324
20G38FDHORX	268	20GS20FLH90-120	211	20MBSPP-20MBSPP-20MBSPP	323
20G38FDHORX45	269	20GS20FLH90M	210	20MBSPP-20MBSPT	314
20G38FDHORX90	270	20GS20HLE	224	20MBSPP-24FBSPPX	318
20G38MDH	271	20GS20HLE90-155	224	20MBSPP-24MBSPP	311
20G3H	55	20GS20MB	220	20MBSPP-24MBSPT	314
20G42FFGX	278	20GS20MBSPP	194	20MBSPP-32FBSPPX	318
20G42MFG	279	20GS20MFFOR	202	20MBSPP-32MBSPP	311
20GMV	57	20GS20MJ	198	20MBSPP-PLUG	326
20GS16FJX	195	20GS20MP	220	20MEGATECH1000	82
20GS16FL	202	20GS24FFORX90-064	200	20MJ-20MBSPPACOR90	334
20GS16FL45M	204	20GS24FJX	195	20PA-FL	296
20GS16FL90M	206	20GS24FL	202	20PH-FLH	296

Ref.	P.	Ref.	P.	Ref.	P.
20TS	348	24GSM24PLSOR	190	24GSP42FDLORX	233
22LG5K	458	24GSM32FLC	186	24GSP42FDLORX45	216
24EFG3K	41	24GSM32FLH	183	24GSP42FDLORX45	233
24EFG5K	39	24GSM32FLH45M	184	24GSP42FDLORX90	217
24EFG5KL	59	24GSM32FLH90S	185	24GSP42FDLORX90	233
24EFG6K	38	24GSM38FDHORX	188	24GSP42MDL	217
24FBSPP-24FBSPP	320	24GSM38FDHORX45	188	24GSP42MDL	234
24FBSPPX-24FBSPPX	319	24GSM38FDHORX90	189	24M2T	48
24FBSPPX-24FBSPPX-24FBSPPX	325	24GSP1F-2	228	24MBSPP-16FBSPPX	318
24FBSPPX-CAP	327	24GSP1F-4	192	24MBSPP-20FBSPPX	318
24FILOR-24MSH	191	24GSP24FBSPORX	193	24MBSPP-20MBSPT	314
24FJ-NUT	348	24GSP24FBSPORX	228	24MBSPP-24MBSPPBKHD	313
24FJX-16MJ	349	24GSP24FBSPORX45	193	24MBSPP-24FBSPPX	318
24FJX-24MBSPPCOR	345	24GSP24FBSPORX45	228	24MBSPP-24MBSPP	310
24FLHCFM	297	24GSP24FBSPORX90	194	24MBSPP-24MBSPP-24MBSPP	323
24G1	51	24GSP24FBSPORX90	228	24MBSPP-24MBSPT	314
24G1H	67	24GSP24FFORX	199	24MBSPP-32FBSPPX	318
24G2	50	24GSP24FFORX	231	24MBSPP-32MBSPP	311
24G2H	65	24GSP24FJX	195	24MBSPP-PLUG	326
24G2L	66	24GSP24FJX	228	24MEGATECH500	82
24G2XH	64	24GSP24FJX45-050	196	24MJ-20MBSPPCOR	332
24GMV	57	24GSP24FJX45-050	230	24MJ-24MBSPPACOR90	334
24GSM24FBSPORX	178	24GSP24FJX90-089	197	24PA-FL	296
24GSM24FBSPORX45	178	24GSP24FJX90-089	230	24PH-FLH	296
24GSM24FBSPORX90	178	24GSP24FL	202	25TS	348
24GSM24FFORX	180	24GSP24FL	231	26LG5K	566
24GSM24FFORX45-038	181	24GSP24FL30S	203	2FBSPP-2FBSPP	320
24GSM24FFORX90M	181	24GSP24FL30S	231	2FBSPPX-2FBSPPX	319
24GSM24FILOR	190	24GSP24FL45S	204	2FBSPPX-CAP	327
24GSM24FJX	179	24GSP24FL45S	232	2JC05	89
24GSM24FJX45-034	179	24GSP24FL60S	204	2JC05B	89
24GSM24FJX90M	180	24GSP24FL60S	232	2JC06	89
24GSM24FL	181	24GSP24FL90S	205	2JC06B	89
24GSM24FL45M	182	24GSP24FL90S	232	2JC06G	89
24GSM24FL90S	182	24GSP24MBSPP	194	2JC08B	89
24GSM24FLC	186	24GSP24MBSPP	228	2MBSPP-2MBSPPBKHD	313
24GSM24FLC22-017	186	24GSP24MJ	198	2MBSPP-2FBSPPX	318
24GSM24FLC30-023	187	24GSP24MJ	230	2MBSPP-2MBSPP	310
24GSM24FLC45-039	187	24GSP24MP	220	2MBSPP-2MBSPT	314
24GSM24FLC90-087	188	24GSP24MP	235	2MBSPP-2MBSPPWD	312
24GSM24FLH	183	24GSP32FL	202	2MBSPP-4FBSPPX	318
24GSM24FLH22M	184	24GSP32FL	231	2MBSPP-4MBSPP	311
24GSM24FLH30M	184	24GSP32FL45S	204	2MBSPP-4MBSPT	314
24GSM24FLH45M	184	24GSP32FL45S	232	2MBSPP-4MBSPPWD	312
24GSM24FLH60M	185	24GSP32FL90-080	206	2MBSPP-6MBSPP	311
24GSM24FLH90-094	185	24GSP32FL90-080	232	2MBSPP-8MBSPP	311
24GSM24FLHCFM	182	24GSP38FDHORX	218	2MBSPP-PLUG	326
24GSM24FLHCFM45M	183	24GSP38FDHORX	234	30TS	348
24GSM24FLHCFM90-094	183	24GSP38FDHORX45	218	32EFG3K	41
24GSM24MBSPP	179	24GSP38FDHORX45	234	32EFG5K	39
24GSM24MILX	190	24GSP38FDHORX90	219	32EFG6K	38
24GSM24MJ	180	24GSP38FDHORX90	235	32FBSPP-32FBSPP	320
24GSM24MP	189	24GSP42FDLORX	216	32FBSPPX-32FBSPPX	319

PRODUCT INDEX

INTEGRATED FLUID POWER SOLUTIONS

Ref.	P.	Ref.	P.	Ref.	P.
32FBSPPX-CAP	327	32GSP32MBSPP	194	6FQLH-18MMOR	353
32FILOR-32MSH	191	32GSP32MBSPP	228	6FQLH-4MB	353
32FLHCFM	297	32GSP32MJ	198	6FQLH-4MBSPPCSC	352
32G1	51	32GSP32MJ	230	6FQLH-6MB	353
32G1H	67	32GSP32MP	220	6FQLH-6MBSPPBKHD	352
32G2	50	32GSP32MP	235	6FQLH-6MBSPPCSC	352
32G2H	65	32LG4K	566	6FQLH-8MB	353
32G2L	66	32M2T	48	6FQLH-8MBSPPCSC	352
32G2XH	64	32MBSPP-20FBSPPX	318	8FQLH-10MB	353
32GMV	57	32MBSPP-24FBSPPX	318	8FQLH-12MBSPPCSC	352
32GSM24FLH	183	32MBSPP-32MBSPPBKHD	313	8FQLH-18MMOR	353
32GSM32FBSPORX	178	32MBSPP-32FBSPPX	318	8FQLH-22MMOR	353
32GSM32FBSPORX45	178	32MBSPP-32MBSPP	310	8FQLH-6MB	353
32GSM32FBSPORX90	178	32MBSPP-32MBSPT	314	8FQLH-6MBSPPCSC	352
32GSM32FILOR	190	32MBSPP-32MP	317	8FQLH-8MB	353
32GSM32FJX	179	32MBSPP-PLUG	326	8FQLH-8MBSPPBKHD	352
32GSM32FL	181	32MEGATECH500	82	8FQLH-8MBSPPCSC	352
32GSM32FL45M	182	32PA-FL	296	A 4-LL/M 6 x 1	370
32GSM32FL90-130	182	32PH-FLH	296	A 4-MLL	370
32GSM32FLC	186	38TS	348	A 4-RLL	368
32GSM32FLC45-064	187	40GMV	57	A 6-MLL	370
32GSM32FLC90-130	188	40MEGATECH500	82	A 6-RLL	368
32GSM32FLH	183	4219BF 1/2"	75	A 8-MLL	370
32GSM32FLH45-063	184	4219BF 1/4"	75	A 8-RLL	368
32GSM32FLH90M	185	4219BF 3/16"	75	A 4-LL/NPT	373
32GSM32FLHCFM	182	4219BF 3/8"	75	A 6-LL/NPT	373
32GSM32FLHCFM45-063	183	4219BF 5/16"	75	A 8-LL/NPT	373
32GSM32FLHCFM90S	183	4219BG 1/2"	74	ABO 6-L	494
32GSM32MBSPP	179	4219BG 1/4"	74	ABO 6-S	494
32GSM32MILX	190	4219BG 3/16"	74	ABO 8-L	494
32GSM32MJ	180	4219BG 3/8"	74	ABO 8-S	494
32GSM32MP	189	4219BG 5/16"	74	ABO 10-L	494
32GSM32PLSOR	190	4219G 1/2"	76	ABO 10-S	494
32GSP1F-2	228	4219G 1/4"	76	ABO 12-L	494
32GSP1F-4	192	4219G 3/16"	76	ABO 12-S	494
32GSP32FBSPORX	193	4219G 3/4"	76	ABO 14-S	494
32GSP32FBSPORX	228	4219G 3/8"	76	ABO 15-L	494
32GSP32FBSPORX45	193	4219G 5/16"	76	ABO 16-S	494
32GSP32FBSPORX45	228	4219G 5/8"	76	ABO 18-L	494
32GSP32FBSPORX90	194	48GMV	57	ABO 20-S	494
32GSP32FBSPORX90	228	48MEGATECH500	82	ABO 22-L	494
32GSP32FJX	195	4FQLH-12MMOR	353	ABO 25-S	494
32GSP32FJX	228	4FQLH-14MMOR	353	ABO 28-L	494
32GSP32FJX45-065	196	4FQLH-4MB	353	ABO 30-S	494
32GSP32FJX45-065	230	4FQLH-4MBSPPBKHD	352	ABO 35-L	494
32GSP32FJX90M	197	4FQLH-4MBSPPCSC	352	ABO 38-S	494
32GSP32FJX90M	230	4FQLH-6MB	353	ABO 42-L	494
32GSP32FL	202	4FQLH-6MBSPPCSC	352	AIR MASTER DIVING UMBILICAL 1000 3/8"	124
32GSP32FL	231	56GMV	57	AIR MASTER DIVING UMBILICAL 1125 1/2"	124
32GSP32FL45-066	204	64GMV	57	ARVA 10-RL	469
32GSP32FL45-066	232	6FQLH-12MBSPPCSC	352	ARVA 4-RLL	469
32GSP32FL90-114	206	6FQLH-14MMOR	353	ARVA 6-RLL	469
32GSP32FL90-114	232	6FQLH-16MMOR	353	ARVA 6-RS	469

Ref.	P.	Ref.	P.	Ref.	P.
ARVA 8-RL	469	BLUE STRIPE 1.3/4"	72	CEMENT MAS D 90mm x CL40	126
ARVA 8-RLL	469	BLUE STRIPE 1"	72	CEMENT MAS SD 102mm x CL40	127
ARVW 10-RL	469	BLUE STRIPE 1/2"	72	CEMENT MAS SD 110mm x CL40	127
ARVW 4-RLL	469	BLUE STRIPE 2 1/4"	72	CEMENT MAS SD 127mm x CL40	127
ARVW 6-RLL	469	BLUE STRIPE 2"	72	CEMENT MAS SD 152mm x CL40	127
ARVW 6-RS	469	BLUE STRIPE 3/4"	72	CEMENT MAS SD 203mm x CL40	127
ARVW 8-RL	469	BLUE STRIPE 3/8"	72	CEMENT MAS SD 51mm x CL40	127
ARVW 8-RLL	469	BLUE STRIPE 5/8"	72	CEMENT MAS SD 63mm x CL40	127
B 4-LL/NPT	379	BLUE STRIPE 7/8"	72	CEMENT MAS SD 76mm x CL40	127
B 6-LL/NPT	379	BMO-10L	495	CEMENT MAS SD 80mm x CL40	127
B 8-LL/NPT	379	BMO-10S	495	CEMENT MAS SD 90mm x CL40	127
B 8-RLL	377	BMO-12L	495	CHEM MAS EPDM D 100mm x CL40	103
B 4-MLL	378	BMO-12S	495	CHEM MAS EPDM D 101.5mm x CL40	103
B 4-RLL	377	BMO-14S	495	CHEM MAS EPDM D 13mm x CL40	103
B 6-MLL	378	BMO-15L	495	CHEM MAS EPDM D 19mm x CL40	103
B 6-RLL	377	BMO-16S	495	CHEM MAS EPDM D 22mm x CL40	103
B 8-MLL	378	BMO-18L	495	CHEM MAS EPDM D 25mm x CL40	103
BAO 6-L/S	495	BMO-20S	495	CHEM MAS EPDM D 32mm x CL40	103
BAO 8-L/S	495	BMO-22L	495	CHEM MAS EPDM D 38mm x CL40	103
BAO 10-L/S	495	BMO-25S	495	CHEM MAS EPDM D 50mm x CL40	103
BAO 12-L/S	495	BMO-28L	495	CHEM MAS EPDM D 51mm x CL40	103
BAO 14-S	495	BMO-30S	495	CHEM MAS EPDM D 63mm x CL40	103
BAO 15-L	495	BMO-35L	495	CHEM MAS EPDM D 75mm x CL40	103
BAO 16-S	495	BMO-38S	495	CHEM MAS EPDM D 76mm x CL40	103
BAO 18-L	495	BMO-42L	495	CHEM MAS EPDM SD 100mm x CL40	104
BAO 20-S	495	BMO-6L	495	CHEM MAS EPDM SD 101.5mm x CL40	104
BAO 22-L	495	BMO-6S	495	CHEM MAS EPDM SD 150mm x CL40	104
BAO 25-S	495	BMO-8L	495	CHEM MAS EPDM SD 19mm x CL40	104
BAO 28-L	495	BMO-8S	495	CHEM MAS EPDM SD 25mm x CL40	104
BAO 30-S	495	BUNKER MAS D 102mm x CL40	97	CHEM MAS EPDM SD 32mm x CL40	104
BAO 35-L	495	BUNKER MAS D 127mm x CL40	97	CHEM MAS EPDM SD 38mm x CL40	104
BAO 38-S	495	BUNKER MAS D 152mm x CL40	97	CHEM MAS EPDM SD 50mm x CL40	104
BAO 42-L	495	BUNKER MAS D 203mm x CL40	97	CHEM MAS EPDM SD 51mm x CL40	104
BE 4-MLL/M10x1/0	432	BUNKER MAS D 254mm x CL40	97	CHEM MAS EPDM SD 63mm x CL40	104
BE 4-MLL/O	432	BUNKER MAS D 76mm x CL40	97	CHEM MAS EPDM SD 75mm x CL40	104
BE 4-RLL/OA	434	C 4-LL/NPT	382	CHEM MAS EPDM SD 76mm x CL40	104
BE 6-MLL/M12x1,5/0	432	C 6-LL/NPT	382	CHEM MAS UHMWPE SD 100mm x CL40	105
BE 6-MLL/O	432	C 8-LL/NPT	382	CHEM MAS UHMWPE SD 101.5mm x CL40	105
BE 6-RLL/OA	432	C 4-MLL	381	CHEM MAS UHMWPE SD 13mm x CL40	105
BEVERAGE MAS D 102mm x CL40	113	C 4-RLL	380	CHEM MAS UHMWPE SD 19mm x CL40	105
BEVERAGE MAS D 13mm x CL40	113	C 6-MLL	381	CHEM MAS UHMWPE SD 25mm x CL40	105
BEVERAGE MAS D 19mm x CL40	113	C 6-RLL	380	CHEM MAS UHMWPE SD 32mm x CL40	105
BEVERAGE MAS D 25mm x CL40	113	C 8-MLL	381	CHEM MAS UHMWPE SD 38mm x CL40	105
BEVERAGE MAS D 32mm x CL40	113	C 8-RLL	380	CHEM MAS UHMWPE SD 50mm x CL40	105
BEVERAGE MAS D 38mm x CL40	113	CAM 34	539	CHEM MAS UHMWPE SD 51mm x CL40	105
BEVERAGE MAS D 40mm x CL40	113	CAM 34 DP	539	CHEM MAS UHMWPE SD 63mm x CL40	105
BEVERAGE MAS D 51mm x CL40	113	CAM 34 power pack	539	CHEM MAS UHMWPE SD 75mm x CL40	105
BEVERAGE MAS D 63mm x CL40	113	CEMENT MAS D 102mm x CL40	126	CHEM MAS XLPE SD 100mm x CL40	102
BEVERAGE MAS D 76mm x CL40	113	CEMENT MAS D 110mm x CL40	126	CHEM MAS XLPE SD 19mm x CL40	102
BEVERAGE MAS D 80mm x CL40	113	CEMENT MAS D 51mm x CL40	126	CHEM MAS XLPE SD 25mm x CL40	102
BLUE STRIPE 1.1/2"	72	CEMENT MAS D 63mm x CL40	126	CHEM MAS XLPE SD 32mm x CL40	102
BLUE STRIPE 1.1/4"	72	CEMENT MAS D 76mm x CL40	126	CHEM MAS XLPE SD 38mm x CL40	102
BLUE STRIPE 1.1/8"	72	CEMENT MAS D 80mm x CL40	126	CHEM MAS XLPE SD 50mm x CL40	102

PRODUCT INDEX

INTEGRATED FLUID POWER SOLUTIONS

Ref.	P.	Ref.	P.	Ref.	P.
CHEM MAS XLPE SD 51mm x CL40	102	CMM G 1/4-40	523	CSHK M 12 x 1,5/WD	519
CHEM MAS XLPE SD 65mm x CL40	102	CMM G 1/4-400	523	CSHK M 14 x 1,5	519
CHEM MAS XLPE SD 75mm x CL40	102	CMM G 1/4-60	523	CSHK M 16 x 1,5	519
CHEM MAS XLPE SD 76mm x CL40	102	CMM G 1/4-600	523	CSHK M 8 x 1	519
CHEM MASTER PAINT SPRAY 1/2"	107	CONCRETE MAS D 19mm x CL40	130	CSHK R 1/4"	519
CHEM MASTER PAINT SPRAY 1/4"	107	CONCRETE MAS D 25mm x CL40	130	CSHK R 1/4" K	519
CHEM MASTER PAINT SPRAY 3/4"	107	CONCRETE MAS D 32mm x CL40	130	CSHK R 1/4"/WD	519
CHEM MASTER PAINT SPRAY 3/8"	107	CONCRETE MAS D 35mm x CL40	130	CSHK R 1/8" K	519
CHEM MASTER PAINT SPRAY 5/16"	107	CONCRETE MAS D 38mm x CL40	130	CSHK R 1/8"/WD	519
CHEM MAS XTRM FEP SD 1.1/2"	106	CONCRETE MAS D 50mm x CL40	130	CSHK R 3/8"	519
CHEM MAS XTRM FEP SD 1"	106	CONCRETE MAS D 63mm x CL40	130	CSHKS 6-L	521
CHEM MAS XTRM FEP SD 2.1/2"	106	CS12MSAD	524	CSHKS 6-S	521
CHEM MAS XTRM FEP SD 2"	106	CSAD/CSH-CS 12	510	CSHKS 8-L	521
CHEM MAS XTRM FEP SD 3"	106	CSAD/CSH-CSS	510	CSHKS 8-S	521
CHEM MAS XTRM FEP SD 3/4"	106	CSAD/CSH-CST	510	CSHKS 10-L	521
CHEM MAS XTRM FEP SD 4"	106	CSAD/CSS-CS 12	517	CSHKS 10-S	521
CLEAN MASTER PRESSURE WASH 2500B 1WB 1/2"	91	CSAD/CSS-CSH	517	CSHKS 12-L	521
CLEAN MASTER PRESSURE WASH 2500G 1WB 1/2"	91	CSAD/CSS-CST	517	CSHKS 12-S	521
CLEAN MASTER PRESSURE WASH 3000 1WB 3/8"	91	CSAS-G 1/4"	517	CSHKS 14-S	521
CLEAN MASTER PRESSURE WASH 3000B 1WB 3/8"	91	CSAS-M 10 x 1	517	CSHKS 15-L	521
CLEAN MASTER PRESSURE WASH 3000G 1WB 3/8"	91	CSH 1/2" UNF	505	CSHKS 16-S	521
CLEAN MASTER PRESSURE WASH 3500 1WB 1/4"	91	CSH 1/4" NPT	505	CSHKS 18-L	521
CLEAN MASTER PRESSURE WASH 3600 1WB 5/16"	91	CSH 1/8" NPT	505	CSHKS 20-S	521
CLEAN MASTER PRESSURE WASH 3600B 1WB 5/16"	91	CSH 5/16" UNF	505	CSHKS 22-L	521
CLEAN MASTER PRESSURE WASH 4000B 2WB 1/2"	91	CSH 7/16" UNF	505	CSHKS 25-S	521
CLEAN MASTER PRESSURE WASH 5000 2WB 3/8"	91	CSH 9/16" UNF	505	CSHKS 28-L	521
CLEAN MASTER PRESSURE WASH 5000 2WB 5/16"	91	CSH M 8 x 1	505	CSHKS 30-S	521
CLEAN MASTER PRESSURE WASH 5000B 2WB 3/8"	91	CSH M 10 x 1	505	CSHKS 35-L	521
CLEAN MASTER PRESSURE WASH 5000B 2WB 5/16"	91	CSH M 12 x 1,5/WD	505	CSHKS 38-S	521
CLEAN MASTER PRESSURE WASH 5000G 2WB 3/8"	91	CSH M 14 x 1,5	505	CSHKS 42-L	521
CM2T04	47	CSH M 16 x 1,5	505	CSHMSAD	524
CM2T05	47	CSH R 1/4"	505	CSH0-R 1/2"	508
CM2T06	47	CSH R 1/4" K	505	CSH0-R 1/4"	508
CM2T08	47	CSH R 1/4"/WD	505	CSH-RS-G 1/2	509
CM2T10	47	CSH R 1/8"	505	CSH-RS-G 1/8	509
CM2T12	47	CSH R 1/8" K	505	CSH-RS-G 3/8	509
CM2T16	47	CSH R 1/8"/WD	505	CSH-RS-M 16 x 1,5	509
CMM G 1/2-10	523	CSH R 3/8"	505	CSH-RS-R 1/4 K	509
CMM G 1/2-100	523	CSH R 3/8"/WD	505	CSHS 6-L	507
CMM G 1/2-16	523	CSH SK	509	CSHS 6-S	507
CMM G 1/2-160	523	CSH SK 8-S	509	CSHS 8-L	507
CMM G 1/2-25	523	CSH SK 12-L	509	CSHS 8-S	507
CMM G 1/2-250	523	CSHD-1/2 NPT	508	CSHS 10-L	507
CMM G 1/2-40	523	CSHD-1/4 NPT	508	CSHS 10-S	507
CMM G 1/2-400	523	CSHD-G 1/2	508	CSHS 12-L	507
CMM G 1/2-60	523	CSHD-G 1/4	508	CSHS 12-S	507
CMM G 1/2-600	523	CSHK 1/2" UNF	519	CSHS 14-S	507
CMM G 1/4-10	523	CSHK 1/4" NPT	519	CSHS 15-L	507
CMM G 1/4-100	523	CSHK 1/8" NPT	519	CSHS 16-S	507
CMM G 1/4-16	523	CSHK 5/16" UNF	519	CSHS 18-L	507
CMM G 1/4-160	523	CSHK 7/16" UNF	519	CSHS 20-S	507
CMM G 1/4-25	523	CSHK 9/16" UNF	519	CSHS 22-L	507
CMM G 1/4-250	523	CSHK M 10 x 1	519	CSHS 25-S	507

Ref.	P.	Ref.	P.	Ref.	P.
CSSH 28-L	507	CSTO-1/4 NPT	501	DKA M16	480
CSSH 30-S	507	CSTO-G 1/2"	501	DKA M16/SA3	479
CSSH 35-L	507	CSTO-G 1/4"	501	DKA M18	480
CSSH 38-S	507	CSTS 6-L	503	DKA M18/SA3	479
CSSH 42-L	507	CSTS 6-S	503	DKA M20	480
CSS 1/4" NPT	512	CSTS 8-L	503	DKA M20/SA3	479
CSS 9/16" UNF	512	CSTS 8-S	503	DKA M22	480
CSS M 10 x 1	512	CSTS 10-L	503	DKA M26	480
CSS M 14 x 1,5	512	CSTS 10-S	503	DKA M27	480
CSS M 16 x 1,5	512	CSTS 12-L	503	DKA R 1/2"	480
CSS R 1/4"	512	CSTS 12-S	503	DKA R 1/2"/SA 4,5	479
CSS R 1/4" K	512	CSTS 14-S	503	DKA R 1/4"	479
CSS R 1/4"/WD	512	CSTS 15-L	503	DKA R 1/4"/SA 3	479
CSS R 3/8"	512	CSTS 16-S	503	DKA R 1/8"/M10	480
CSS SK	516	CSTS 18-L	503	DKA R 1/8"/SA 2,5	479
CSS SK 8-S	516	CSTS 20-S	503	DKA R 1"/M33	480
CSSD-1/2 NPT	514	CSTS 22-L	503	DKA R 1"/M33/SA3,5	479
CSSD-1/4 NPT	514	CSTS 25-S	503	DKA R 1 1/2"/M48	480
CSSD-6 1/2	514	CSTS 28-L	503	DKA R 1 1/2"/M48/SA3,5	479
CSSD-6 1/4	514	CSTS 30-S	503	DKA R 1 1/4"/M42	480
CSSMSAD	524	CSTS 35-L	503	DKA R 1 1/4"/M42/SA3,5	479
CSSO-1/2 NPT	515	CSTS 38-S	503	DKA R 3/4"	480
CSSO-1/4 NPT	515	CSTS 42-L	503	DKA R 3/8"	480
CSSO-R 1/2"	515	D 4-LL/NPT	385	DKA R 3/8"/SA 3	479
CSSO-R 1/4"	515	D 4-MLL	384	DKAD M 22	480
CSS-RS-6 1/2	515	D 4-RLL	400	DKAD M 26	480
CSS-RS-6 3/8	515	D 6-LL/NPT	385	DKAD M 27	480
CSS-RS-M 18 x 1,5	515	D 6-MLL	384	DKAD M26	480
CSS-RS-M 20 x 1,5	515	D 6-RLL	400	DKAD M27	480
CSSS 6-L	514	D 8-LL/NPT	385	DKAD R 1/2"	480
CSSS 6-S	514	D 8-MLL	384	DKAD R 3/4"	480
CSSS 8-L	514	D 8-RLL	400	DKI R 1/2"	481
CSSS 8-S	514	DAIRY MAS lite SD 102mm x CL40	109	DKI R 1/4"	481
CSSS 10-L	514	DAIRY MAS lite SD 32mm x CL40	109	DS 10-L/S	472
CSSS 10-S	514	DAIRY MAS lite SD 38mm x CL40	109	DS 12-L/S	472
CSSS 12-L	514	DAIRY MAS lite SD 40mm x CL40	109	DS 14-S	472
CSSS 12-S	514	DAIRY MAS lite SD 45mm x CL40	109	DS 15-L	472
CSSS 14-S	514	DAIRY MAS lite SD 51mm x CL40	109	DS 16-S	472
CSSS 15-L	514	DAIRY MAS lite SD 63mm x CL40	109	DS 18-L	472
CSSS 16-S	514	DAIRY MAS lite SD 76mm x CL40	109	DS 20-S	472
CSSS 18-L	514	DAIRY MAS SD 102mm x CL40	108	DS 22-L	472
CSSS 20-S	514	DAIRY MAS SD 32mm x CL40	108	DS 25-S	472
CSSS 22-L	514	DAIRY MAS SD 38mm x CL40	108	DS 28-L	472
CSSS 25-S	514	DAIRY MAS SD 40mm x CL40	108	DS 30-S	472
CSSS 28-L	514	DAIRY MAS SD 45mm x CL40	108	DS 35-L	472
CSSS 30-S	514	DAIRY MAS SD 51mm x CL40	108	DS 38-S	472
CSSS 35-L	514	DAIRY MAS SD 63mm x CL40	108	DS 42-L	472
CSSS 38-S	514	DAIRY MAS SD 76mm x CL40	108	DS 6-L/S	472
CSSS 42-L	514	DKA M10/SA2,5	479	DS 8-L/S	472
CST M 8 x 1	501	DKA M12	480	DS- VADKO 6-L/NPT	428
CST M 10 x 1	501	DKA M12/SA3	479	DS- VADKO 6-S/NPT	428
CST R 1/8" K	501	DKA M14	480	DS- VADKO 8-L/NPT	428
CSTO-1/2 NPT	501	DKA M14/SA3	479	DS- VADKO 8-S/NPT	428

PRODUCT INDEX

INTEGRATED FLUID POWER SOLUTIONS

Ref.	P.	Ref.	P.	Ref.	P.
DS- VADKO 10-L/NPT	428	DS-A 10-ML	370	DS-A 14-MS	370
DS- VADKO 10-S/NPT	428	DS-A 10-ML/O	375	DS-A 14-MS/WD	372
DS- VADKO 12-L/NPT	428	DS-A 10-ML/WD	372	DS-A 14-RS	369
DS- VADKO 12-S/NPT	428	DS-A 10-MS	370	DS-A 14-RS/WD	371
DS- VADKO 14-S/NPT	428	DS-A 10-MS/O	375	DS-A 14-S / NPT	373
DS- VADKO 15-L/NPT	428	DS-A 10-MS/WD	372	DS-A 14-S/R 3/8"	369
DS- VADKO 16-S/NPT	428	DS-A 10-RL	368	DS-A 15-L / NPT	373
DS- VADKO 18-L/NPT	428	DS-A 10-RL/WD	371	DS-A 15-L/3/4"-16 UNF	376
DS- VADKO 20-S/NPT	428	DS-A 10-RS	369	DS-A 15-L/7/8"-14 UNF	376
DS- VADKO 22-L/NPT	428	DS-A 10-RS/WD	371	DS-A 15-L/M 16 x 1,5	370
DS- VADKO 25-S/NPT	428	DS-A 10-S / NPT	373	DS-A 15-L/M 22 x 1,5	370
DS- VADKO 28-L/NPT	428	DS-A 10-S 1/4" / NPT	373	DS-A 15-L/M 22x1,5/WD	372
DS- VADKO 30-S/NPT	428	DS-A 10-S/9/16"-18 UNF	376	DS-A 15-L/R 3/4"	368
DS- VADKO 35-L/NPT	428	DS-A 10-S/R 1/2"	369	DS-A 15-L/R 3/8"/WD	371
DS- VADKO 38-S/NPT	428	DS-A 10-S/R 1/2"/WD	371	DS-A 15-L/R 3/8"	368
DS- VADKO 42-L/NPT	428	DS-A 10-S/R 1/4"	369	DS-A 15-ML	370
DS-A 6-L / NPT	373	DS-A 10-S/R 1/4"/WD	371	DS-A 15-ML/O	375
DS-A 6-L 1/4" / NPT	373	DS-A 12-L / NPT	373	DS-A 15-ML/WD	372
DS-A 6-L/R 1/4"/WD	371	DS-A 12-L 1/2" / NPT	373	DS-A 15-RL	368
DS-A 6-ML	370	DS-A 12-L 1/4" / NPT	373	DS-A 15-RL/WD	371
DS-A 6-ML/O	375	DS-A 12-L/3/4"-16 UNF	376	DS-A 16-MS	370
DS-A 6-MS	370	DS-A 12-L/7/16"-20 UNF	376	DS-A 16-MS/O	375
DS-A 6-MS/WD	372	DS-A 12-L/7/8"-14 UNF	376	DS-A 16-MS/WD	372
DS-A 6-RL/WD	371	DS-A 12-L/M 14 x 1,5	370	DS-A 16-RS	369
DS-A 6-RS	369	DS-A 12-L/M 18 x 1,5	370	DS-A 16-RS/WD	371
DS-A 6-RS/WD	371	DS-A 12-L/M 18x1,5/WD	372	DS-A 16-S / NPT	373
DS-A 6-S / NPT	373	DS-A 12-L/M 22 x 1,5	370	DS-A 16-S/3/4"-16 UNF	376
DS-A 6-S/R 1/2"	369	DS-A 12-L/M 22x1,5/WD	372	DS-A 16-S/7/8"-14 UNF	376
DS-A 8-L / NPT	373	DS-A 12-L/R 1/2"/WD	371	DS-A 16-S/M 18 x 1,5	370
DS-A 8-L/7/16"-20 UNF	376	DS-A 12-L/R 1/2"	368	DS-A 16-S/R 3/4"	369
DS-A 8-L/M 18 x 1,5	370	DS-A 12-L/R 1/4"/WD	371	DS-A 16-S/R 3/4"/WD	371
DS-A 8-L/R 1/8"/WD	371	DS-A 12-L/R 1/4"	368	DS-A 16-S/R 3/8"	369
DS-A 8-L/R 3/8"/WD	371	DS-A 12-L/R 3/4"	368	DS-A 16-S/R 3/8"/WD	371
DS-A 8-ML	370	DS-A 12-ML	370	DS-A 18-L / NPT	373
DS-A 8-ML/O	375	DS-A 12-ML/O	375	DS-A 18-L/3/4"-16 UNF	376
DS-A 8-MS	370	DS-A 12-ML/WD	372	DS-A 18-L/7/8"-14 UNF	376
DS-A 8-MS/WD	372	DS-A 12-MS	370	DS-A 18-L/M 18 x 1,5	370
DS-A 8-RL/WD	371	DS-A 12-MS/O	375	DS-A 18-L/R 3/4"/WD	371
DS-A 8-RS	369	DS-A 12-MS/WD	372	DS-A 18-L/R 3/4"	368
DS-A 8-RS/WD	371	DS-A 12-RL	368	DS-A 18-L/R 3/8"	368
DS-A 8-S / NPT	373	DS-A 12-RL/WD	371	DS-A 18-ML	370
DS-A 8-S/7/16"-20 UNF	376	DS-A 12-RS	369	DS-A 18-ML/O	375
DS-A 8-S/R 3/8"	369	DS-A 12-RS/WD	371	DS-A 18-ML/WD	372
DS-A 8-S/R 3/8"/WD	371	DS-A 12-S / NPT	373	DS-A 18-RL	368
DS-A 10-L / NPT	373	DS-A 12-S 1/2" / NPT	373	DS-A 18-RL/WD	371
DS-A 10-L 3/8" / NPT	373	DS-A 12-S 1/4" / NPT	373	DS-A 20-MS	370
DS-A 10-L/M 16 x 1,5	370	DS-A 12-S 3/4"-16 UNF	376	DS-A 20-MS/O	375
DS-A 10-L/M 18 x 1,5	370	DS-A 12-S 9/16"-18 UNF	376	DS-A 20-MS/WD	372
DS-A 10-L/M 22 x 1,5	370	DS-A 12-S/M 22 x 1,5	370	DS-A 20-RS	369
DS-A 10-L/R 1/2"/WD	371	DS-A 12-S/R 1/2"	369	DS-A 20-RS/WD	371
DS-A 10-L/R 1/2"	368	DS-A 12-S/R 1/2"/WD	371	DS-A 20-S / NPT	373
DS-A 10-L/R 3/8"/WD	371	DS-A 12-S/R 1/4"	369	DS-A 20-S 3/4"-16 UNF	376
DS-A 10-L/R 3/8"	368	DS-A 12-S/R 1/4"/WD	371	DS-A 20-S/1 1/16"-12 UN	376

Ref.	P.	Ref.	P.	Ref.	P.
DS-A 20-S/7/8"-14 UNF	376	DS-A 38-RS/WD	371	DS-AI 42-L/R 1 1/2"	452
DS-A 20-S/R 1/2"	369	DS-A 38-S 1 5/8"-12 UN	376	DS-AI 6-L/M 10x1	453
DS-A 22-L / NPT	373	DS-A 38-S/NPT	373	DS-AI 6-L/R 1/8"	452
DS-A 22-L 1 5/16"-12 UN	376	DS-A 38-S/R 1 1/4"	369	DS-AI 6-S/M 12x1,5	453
DS-A 22-L/1 1/16"-12 UN	376	DS-A 42-L / NPT	373	DS-AI 6-S/R 1/4"	452
DS-A 22-L/7/8"-14 UNF	376	DS-A 42-L/1 5/8"-12 UN	376	DS-AI 8-L/M 12x1,5	453
DS-A 22-L/M 22 x 1,5	370	DS-A 42-ML	370	DS-AI 8-L/R 1/4"	452
DS-A 22-L/R 1/2"	369	DS-A 42-ML/WD	372	DS-AI 8-S/M 14x1,5	453
DS-A 22-ML	370	DS-A 42-RL	369	DS-AI 8-S/R 1/4"	452
DS-A 22-ML/0	375	DS-A 42-RL/WD	371	DS-AP 6-L/R 1/8"	374
DS-A 22-ML/WD	372	DS-A 6-L/R 1/2"	368	DS-AP 8-L/R 1/4"	374
DS-A 22-RL	369	DS-A 6-L/R 1/4"	368	DS-AP 10-L/R 1/4"	374
DS-A 22-RL/WD	371	DS-A 6-L/R 3/8"	368	DS-AP 12-L/R 3/8"	374
DS-A 25-MS	370	DS-A 6-ML/WD	372	DS-AP 15-L/R 1/2"	374
DS-A 25-MS/0	375	DS-A 6-MS/0	375	DS-AP 18-L/R 1/2"	374
DS-A 25-MS/WD	372	DS-A 6-RL	368	DS-AP 22-L/R 3/4"	374
DS-A 25-RS	369	DS-A 8-L/R 1/2"	368	DS-AP 28-L/R 1"	374
DS-A 25-RS/WD	371	DS-A 8-L/R 1/8"	368	DS-AP 35-L/R 1 1/4"	374
DS-A 25-S / NPT	373	DS-A 8-L/R 3/8"	368	DS-AP 42-L/R 1 1/2"	374
DS-A 25-S/1 1/16"-12 UN	376	DS-A 8-ML/WD	372	DS-B 6-L/NPT	379
DS-A 25-S/1 5/16"-12 UN	376	DS-A 8-MS/0	375	DS-B 6-ML	378
DS-A 25-S/R 1/2"/WD	371	DS-A 8-RL	368	DS-B 6-MS	378
DS-A 25-S/R 3/4"	369	DS-AI 10-L/M 14x1,5	453	DS-B 6-RL	377
DS-A 28-L / NPT	373	DS-AI 10-L/R 1/4"	452	DS-B 6-RS	377
DS-A 28-L/1 1/16"-12 UN	376	DS-AI 10-S/M 16x1,5	453	DS-B 6-S/NPT	379
DS-A 28-L/1 5/16"-12 UN	376	DS-AI 10-S/R 3/8"	452	DS-B 8-L/NPT	379
DS-A 28-L/R 3/4"	369	DS-AI 12-L/M 16x1,5	453	DS-B 8-ML	378
DS-A 28-ML	370	DS-AI 12-L/R 3/8"	452	DS-B 8-MS	378
DS-A 28-ML/0	375	DS-AI 12-S/M 18x1,5	453	DS-B 8-RL	377
DS-A 28-ML/WD	372	DS-AI 12-S/R 3/8"	452	DS-B 8-RS	377
DS-A 28-RL	369	DS-AI 14-S/M 20x1,5	453	DS-B 8-S/NPT	379
DS-A 28-RL/WD	371	DS-AI 14-S/R 1/2"	452	DS-B 10-L/NPT	379
DS-A 30-MS	370	DS-AI 15-L/M 18x1,5	453	DS-B 10-ML	378
DS-A 30-MS/0	375	DS-AI 15-L/R 1/2"	452	DS-B 10-MS	378
DS-A 30-MS/WD	372	DS-AI 16-S/M 22x1,5	453	DS-B 10-RL	377
DS-A 30-RS	369	DS-AI 16-S/R 1/2"	452	DS-B 10-RS	377
DS-A 30-RS/WD	371	DS-AI 18-L/M 22x1,5	453	DS-B 10-S/NPT	379
DS-A 30-S/1 5/16"-12 UN	376	DS-AI 18-L/R 1/2"	452	DS-B 12-L/NPT	379
DS-A 30-S/1 5/8"-12 UN	376	DS-AI 20-S/M 27x2	453	DS-B 12-ML	378
DS-A 30-S/NPT	373	DS-AI 20-S/R 3/4"	452	DS-B 12-MS	378
DS-A 30-S/R 1"	369	DS-AI 22-L/M 26x1,5	453	DS-B 12-RL	377
DS-A 35-L / NPT	373	DS-AI 22-L/R 3/4"	452	DS-B 12-RS	377
DS-A 35-L/1 5/16"-12 UN	376	DS-AI 25-S/M 33x2	453	DS-B 12-S/NPT	379
DS-A 35-L/1 5/8"-12 UN	376	DS-AI 25-S/R 1"	452	DS-B 14-MS	378
DS-A 35-L/R 1"	369	DS-AI 28-L/M 33x2	453	DS-B 14-RS	377
DS-A 35-ML	370	DS-AI 28-L/R 1"	452	DS-B 14-S/NPT	379
DS-A 35-ML/0	375	DS-AI 30-S/M 42x2	453	DS-B 15-L/NPT	379
DS-A 35-ML/WD	372	DS-AI 30-S/R 1 1/4"	452	DS-B 15-ML	378
DS-A 35-RL	369	DS-AI 35-L/M 42x2	453	DS-B 15-RL	377
DS-A 35-RL/WD	371	DS-AI 35-L/R 1 1/4"	452	DS-B 16-MS	378
DS-A 38-MS	370	DS-AI 38-S/M 48x2	453	DS-B 16-RS	377
DS-A 38-MS/WD	372	DS-AI 38-S/R 1 1/2"	452	DS-B 16-S/NPT	379
DS-A 38-RS	369	DS-AI 42-L/M 48x2	453	DS-B 18-L/NPT	379

PRODUCT INDEX

INTEGRATED FLUID POWER SOLUTIONS

Ref.	P.	Ref.	P.	Ref.	P.
DS-B 18-ML	378	DS-BE 22-L/1 1/16-12UN	433	DS-BFDK0 38-S	420
DS-B 18-RL	377	DS-BE 22-ML/O	432	DS-BFDK0 42-L	420
DS-B 20-S/NPT	379	DS-BE 22-ML/OA	435	DS-BFE 6-ML/O	436
DS-B 22-L/NPT	379	DS-BE 22-RL/OA	434	DS-BFE 6-MS/O	436
DS-B 25-S/NPT	379	DS-BE 25-MS/O	432	DS-BFE 8-ML/O	436
DS-B 28-L/NPT	379	DS-BE 25-MS/OA	435	DS-BFE 8-MS/O	436
DS-B 30-S/NPT	379	DS-BE 25-RS/OA	434	DS-BFE 8-RL/OA	438
DS-B 35-L/NPT	379	DS-BE 25-S/1 1/16-12UN	433	DS-BFE 35-RL/OA	438
DS-B 38-S/NPT	379	DS-BE 28-L/1 5/16-12UN	433	DS-BFE 42-RL/OA	438
DS-B 42-L/NPT	379	DS-BE 28-ML/O	432	DS-BFE 6-RL/OA	438
DS-BE 6-ML/O	432	DS-BE 28-ML/OA	435	DS-BFE 6-RS/OA	438
DS-BE 6-ML/OA	435	DS-BE 28-RL/OA	434	DS-BFE 8-RS/OA	438
DS-BE 6-MS/O	432	DS-BE 30-MS/O	432	DS-BFE 10-L/9/16-18UNF	437
DS-BE 6-MS/OA	435	DS-BE 30-MS/OA	435	DS-BFE 10-ML/O	436
DS-BE 8-ML/O	432	DS-BE 30-RS/OA	434	DS-BFE 10-ML/OA	439
DS-BE 8-ML/OA	435	DS-BE 30-S/1 5/8-12UN	433	DS-BFE 10-MS/O	436
DS-BE 8-MS/O	432	DS-BE 35-L/1 5/8-12UN	433	DS-BFE 10-MS/OA	439
DS-BE 8-MS/OA	435	DS-BE 35-ML/O	432	DS-BFE 10-RL/OA	438
DS-BE 10-L/9/16-18UNF	433	DS-BE 35-ML/OA	435	DS-BFE 10-RS/OA	438
DS-BE 10-ML/O	432	DS-BE 35-RL/OA	434	DS-BFE 10-S/9/16-18UNF	437
DS-BE 10-ML/OA	435	DS-BE 38-MS/O	432	DS-BFE 12-L/3/4-16UNF	437
DS-BE 10-MS/O	432	DS-BE 38-MS/OA	435	DS-BFE 12-L/9/16-18UNF	437
DS-BE 10-MS/OA	435	DS-BE 38-RS/OA	434	DS-BFE 12-ML/O	436
DS-BE 10-RL/OA	434	DS-BE 38-S/1 7/8-12UN	433	DS-BFE 12-ML/OA	439
DS-BE 10-RS/OA	434	DS-BE 42-L/1 7/8-12UN	433	DS-BFE 12-MS/O	436
DS-BE 10-S/9/16-18UNF	433	DS-BE 42-ML/O	432	DS-BFE 12-MS/OA	439
DS-BE 12-L/3/4-16UNF	433	DS-BE 42-ML/OA	435	DS-BFE 12-RL/OA	438
DS-BE 12-L/9/16-18UNF	433	DS-BE 42-RL/OA	434	DS-BFE 12-RS/OA	438
DS-BE 12-ML/O	432	DS-BE 6-L/7/16-20UNF	433	DS-BFE 12-S/3/4-16UNF	437
DS-BE 12-ML/OA	435	DS-BE 6-RL/OA	434	DS-BFE 15-L/3/4-16UNF	437
DS-BE 12-MS/O	432	DS-BE 6-RS/OA	434	DS-BFE 15-L/7/8-14UNF	437
DS-BE 12-MS/OA	435	DS-BE 6-S/7/16-20UNF	433	DS-BFE 15-ML/O	436
DS-BE 12-RL/OA	434	DS-BE 8-L/7/16-20UNF	433	DS-BFE 15-ML/OA	439
DS-BE 12-RS/OA	434	DS-BE 8-RL/OA	434	DS-BFE 15-RL/OA	438
DS-BE 12-S/3/4-16UNF	433	DS-BE 8-RS/OA	434	DS-BFE 16-MS/O	436
DS-BE 15-L/3/4-16UNF	433	DS-BE 8-S/9/16-18UNF	433	DS-BFE 16-MS/OA	439
DS-BE 15-L/7/8-14UNF	433	DS-BFDK0 6-L	420	DS-BFE 16-RS/OA	438
DS-BE 15-ML/O	432	DS-BFDK0 6-S	420	DS-BFE 16-S/7/8-14UNF	437
DS-BE 15-ML/OA	435	DS-BFDK0 8-L	420	DS-BFE 18-L/1 1/6-12UN	437
DS-BE 15-RL/OA	434	DS-BFDK0 8-S	420	DS-BFE 18-L/7/8-14UNF	437
DS-BE 16-MS/O	432	DS-BFDK0 10-L	420	DS-BFE 18-ML/O	436
DS-BE 16-MS/OA	435	DS-BFDK0 10-S	420	DS-BFE 18-ML/OA	439
DS-BE 16-RS/OA	434	DS-BFDK0 12-L	420	DS-BFE 18-RL/OA	438
DS-BE 16-S/7/8-14UNF	433	DS-BFDK0 12-S	420	DS-BFE 20-MS/O	436
DS-BE 18-L/1 1/16-12UN	433	DS-BFDK0 15-L	420	DS-BFE 20-MS/OA	439
DS-BE 18-L/7/8-14UNF	433	DS-BFDK0 16-S	420	DS-BFE 20-RS/OA	438
DS-BE 18-ML/O	432	DS-BFDK0 18-L	420	DS-BFE 20-S/1 1/16-12UN	437
DS-BE 18-ML/OA	435	DS-BFDK0 20-S	420	DS-BFE 22-L/1 1/6-12UN	437
DS-BE 18-RL/OA	434	DS-BFDK0 22-L	420	DS-BFE 22-ML/O	436
DS-BE 20-MS/O	432	DS-BFDK0 25-S	420	DS-BFE 22-ML/OA	439
DS-BE 20-MS/OA	435	DS-BFDK0 28-L	420	DS-BFE 22-RL/OA	438
DS-BE 20-RS/OA	434	DS-BFDK0 30-S	420	DS-BFE 25-MS/O	436
DS-BE 20-S/1 1/16-12UN	433	DS-BFDK0 35-L	420	DS-BFE 25-MS/OA	439

Ref.	P.	Ref.	P.	Ref.	P.
DS-BFE 25-RS/OA	438	DS-C 10-ML	381	DS-CE 6-L/7/16-20UNF	441
DS-BFE 25-S/1 1/16-12UN	437	DS-C 10-MS	381	DS-CE 6-S/7/16-20UNF	441
DS-BFE 28-L/1 5/16-12UN	437	DS-C 10-RL	380	DS-CE 8-L/7/16-20UNF	441
DS-BFE 28-ML/O	436	DS-C 10-RS	380	DS-CE 8-S/9/16-18UNF	441
DS-BFE 28-ML/OA	439	DS-C 10-S/NPT	382	DS-CE 10-ML/O	440
DS-BFE 28-RL/OA	438	DS-C 12-L/NPT	382	DS-CE 10-ML/OA	443
DS-BFE 30-MS/O	436	DS-C 12-ML	381	DS-CE 10-MS/O	440
DS-BFE 30-MS/OA	439	DS-C 12-MS	381	DS-CE 10-MS/OA	443
DS-BFE 30-RS/OA	438	DS-C 12-RL	380	DS-CE 10-RL/OA	442
DS-BFE 30-S/1 5/8-12UN	437	DS-C 12-RS	380	DS-CE 10-RS/OA	442
DS-BFE 35-L/1 5/8-12UN	437	DS-C 12-S/NPT	382	DS-CE 10-S/9/16-18UNF	441
DS-BFE 35-ML/O	436	DS-C 14-MS	381	DS-CE 12-ML/O	440
DS-BFE 35-ML/OA	439	DS-C 14-RS	381	DS-CE 12-ML/OA	443
DS-BFE 38-MS/O	436	DS-C 14-S/NPT	382	DS-CE 12-MS/O	440
DS-BFE 38-MS/OA	439	DS-C 15-L/NPT	382	DS-CE 12-MS/OA	443
DS-BFE 38-RS/OA	438	DS-C 15-ML	381	DS-CE 12-RL/OA	442
DS-BFE 38-S/1 7/8-12UN	437	DS-C 15-RL	380	DS-CE 12-RS/OA	442
DS-BFE 42-L/1 7/8-12UN	437	DS-C 16-MS	381	DS-CE 15-L/7/8-14UNF	441
DS-BFE 42-ML/O	436	DS-C 16-RS	380	DS-CE 15-ML/O	440
DS-BFE 42-ML/OA	439	DS-C 16-S/NPT	382	DS-CE 15-ML/OA	443
DS-BFE 6-L/7/16-20UNF	437	DS-C 18-L/NPT	382	DS-CE 15-RL/OA	442
DS-BFE 6-ML/OA	439	DS-C 18-ML	381	DS-CE 16-MS/O	440
DS-BFE 6-MS/OA	439	DS-C 18-RL	380	DS-CE 16-MS/OA	443
DS-BFE 6-S/7/16-20UNF	437	DS-C 20-S/NPT	382	DS-CE 16-RS/OA	442
DS-BFE 8-L/7/16-20UNF	437	DS-C 22-L/NPT	382	DS-CE 18-L/1 1/6-12UN	441
DS-BFE 8-ML/OA	439	DS-C 25-S/NPT	382	DS-CE 18-L/7/8-14UNF	441
DS-BFE 8-MS/OA	439	DS-C 28-L/NPT	382	DS-CE 18-ML/O	440
DS-BFE 8-S/9/16-18UNF	437	DS-C 30-S/NPT	382	DS-CE 18-ML/OA	443
DS-BS 6-L	397	DS-C 35-L/NPT	382	DS-CE 18-RL/OA	442
DS-BS 6-S	397	DS-C 38-S/NPT	382	DS-CE 20-MS/O	440
DS-BS 8-L	397	DS-C 42-L/NPT	382	DS-CE 20-MS/OA	443
DS-BS 8-S	397	DS-C 6-ML	381	DS-CE 20-RS/OA	442
DS-BS 10-L	397	DS-C 6-MS	381	DS-CE 20-S/1 1/16-12UN	441
DS-BS 10-S	397	DS-C 6-RL	380	DS-CE 22-L/1 1/6-12UN	441
DS-BS 12-L	397	DS-C 6-RS	380	DS-CE 22-ML/O	440
DS-BS 12-S	397	DS-C 8-ML	381	DS-CE 22-ML/OA	443
DS-BS 14-S	397	DS-C 8-MS	381	DS-CE 22-RL/OA	442
DS-BS 15-L	397	DS-C 8-RL	380	DS-CE 25-MS/O	440
DS-BS 16-S	397	DS-C 8-RS	380	DS-CE 25-MS/OA	443
DS-BS 18-L	397	DS-CE 6-ML/OA	443	DS-CE 25-RS/OA	442
DS-BS 20-S	397	DS-CE 6-MS/OA	443	DS-CE 25-S/1 1/16-12UN	441
DS-BS 22-L	397	DS-CE 6-RL/OA	442	DS-CE 28-L/1 5/16-12UN	441
DS-BS 25-S	397	DS-CE 6-RS/OA	442	DS-CE 28-ML/O	440
DS-BS 28-L	397	DS-CE 8-ML/OA	443	DS-CE 28-ML/OA	443
DS-BS 30-S	397	DS-CE 8-MS/OA	443	DS-CE 28-RL/OA	442
DS-BS 35-L	397	DS-CE 8-RL/OA	442	DS-CE 30-MS/O	440
DS-BS 38-S	397	DS-CE 8-RS/OA	442	DS-CE 30-MS/OA	443
DS-BS 42-L	397	DS-CE 10-L/9/16-18UNF	441	DS-CE 30-RS/OA	442
DS-C 6-L/NPT	382	DS-CE 12-L/3/4-16UNF	441	DS-CE 30-S/1 5/8-12UN	441
DS-C 6-S/NPT	382	DS-CE 12-L/9/16-18UNF	441	DS-CE 35-L/1 5/8-12UN	441
DS-C 8-L/NPT	382	DS-CE 12-S/3/4-16UNF	441	DS-CE 35-ML/O	440
DS-C 8-S/NPT	382	DS-CE 15-L/3/4-16UNF	441	DS-CE 35-ML/OA	443
DS-C 10-L/NPT	382	DS-CE 16-S/7/8-14UNF	441	DS-CE 35-RL/OA	442

PRODUCT INDEX

INTEGRATED FLUID POWER SOLUTIONS

Ref.	P.	Ref.	P.	Ref.	P.
DS-CE 38-MS/O	440	DS-CSSE 6-S	513	DS-D 12-MS	384
DS-CE 38-MS/OA	443	DS-CSSE 8-L	513	DS-D 12-RL	383
DS-CE 38-RS/OA	442	DS-CSSE 8-S	513	DS-D 12-RS	383
DS-CE 38-S/1 7/8-12UN	441	DS-CSSE 10-L	513	DS-D 12-S/NPT	385
DS-CE 42-L/1 7/8-12UN	441	DS-CSSE 10-S	513	DS-D 14-MS	384
DS-CE 42-ML/O	440	DS-CSSE 12-L	513	DS-D 14-RS	383
DS-CE 42-ML/OA	443	DS-CSSE 12-S	513	DS-D 14-S/NPT	385
DS-CE 42-RL/OA	442	DS-CSSE 14-S	513	DS-D 15-L/NPT	385
DS-CE 6-ML/O	440	DS-CSSE 15-L	513	DS-D 15-ML	384
DS-CE 6-MS/O	440	DS-CSSE 16-S	513	DS-D 15-RL	383
DS-CE 8-ML/O	440	DS-CSSE 18-L	513	DS-D 16-MS	384
DS-CE 8-MS/O	440	DS-CSSE 20-S	513	DS-D 16-RS	383
DS-CSHE 6-L	506	DS-CSSE 22-L	513	DS-D 16-S/NPT	385
DS-CSHE 6-S	506	DS-CSSE 25-S	513	DS-D 18-L/NPT	385
DS-CSHE 8-L	506	DS-CSSE 28-L	513	DS-D 18-ML	384
DS-CSHE 8-S	506	DS-CSSE 30-S	513	DS-D 18-RL	383
DS-CSHE 10-L	506	DS-CSSE 35-L	513	DS-D 20-S/NPT	385
DS-CSHE 10-S	506	DS-CSSE 38-S	513	DS-D 22-L/NPT	385
DS-CSHE 12-L	506	DS-CSSE 42-L	513	DS-D 25-S/NPT	385
DS-CSHE 12-S	506	DS-CSTE 6-L	502	DS-D 28-L/NPT	385
DS-CSHE 14-S	506	DS-CSTE 6-S	502	DS-D 30-S/NPT	385
DS-CSHE 15-L	506	DS-CSTE 8-L	502	DS-D 35-L/NPT	385
DS-CSHE 16-S	506	DS-CSTE 8-S	502	DS-D 38-S/NPT	385
DS-CSHE 18-L	506	DS-CSTE 10-L	502	DS-D 42-L/NPT	385
DS-CSHE 20-S	506	DS-CSTE 10-S	502	DS-D 6-L/NPT	385
DS-CSHE 22-L	506	DS-CSTE 12-L	502	DS-D 6-ML	384
DS-CSHE 25-S	506	DS-CSTE 12-S	502	DS-D 6-RL	383
DS-CSHE 28-L	506	DS-CSTE 14-S	502	DS-D 8-L/NPT	385
DS-CSHE 30-S	506	DS-CSTE 15-L	502	DS-D 8-ML	384
DS-CSHE 35-L	506	DS-CSTE 16-S	502	DS-D 8-RL	383
DS-CSHE 38-S	506	DS-CSTE 18-L	502	DS-DE 6-ML/O	444
DS-CSHE 42-L	506	DS-CSTE 20-S	502	DS-DE 6-ML/OA	447
DS-CSHKE 6-L	520	DS-CSTE 22-L	502	DS-DE 6-MS/O	444
DS-CSHKE 6-S	520	DS-CSTE 25-S	502	DS-DE 6-MS/OA	447
DS-CSHKE 8-L	520	DS-CSTE 28-L	502	DS-DE 6-RL/OA	446
DS-CSHKE 8-S	520	DS-CSTE 30-S	502	DS-DE 6-RS/OA	446
DS-CSHKE 10-L	520	DS-CSTE 35-L	502	DS-DE 8-ML/O	444
DS-CSHKE 10-S	520	DS-CSTE 38-S	502	DS-DE 8-ML/OA	447
DS-CSHKE 12-L	520	DS-CSTE 42-L	502	DS-DE 8-MS/O	444
DS-CSHKE 12-S	520	DS-D 6-S/NPT	385	DS-DE 8-MS/OA	447
DS-CSHKE 14-S	520	DS-D 8-S/NPT	385	DS-DE 8-RL/OA	446
DS-CSHKE 15-L	520	DS-D 6-MS	384	DS-DE 8-RS/OA	446
DS-CSHKE 16-S	520	DS-D 6-RS	383	DS-DE 6-L/7/16-20UNF	445
DS-CSHKE 18-L	520	DS-D 8-MS	384	DS-DE 8-L/7/16-20UNF	445
DS-CSHKE 20-S	520	DS-D 8-RS	383	DS-DE 10-L/9/16-18UNF	445
DS-CSHKE 22-L	520	DS-D 10-L/NPT	385	DS-DE 10-ML/O	444
DS-CSHKE 25-S	520	DS-D 10-ML	384	DS-DE 10-ML/OA	447
DS-CSHKE 28-L	520	DS-D 10-MS	384	DS-DE 10-MS/O	444
DS-CSHKE 30-S	520	DS-D 10-RL	383	DS-DE 10-MS/OA	447
DS-CSHKE 35-L	520	DS-D 10-RS	383	DS-DE 10-RL/OA	446
DS-CSHKE 38-S	520	DS-D 10-S/NPT	385	DS-DE 10-RS/OA	446
DS-CSHKE 42-L	520	DS-D 12-L/NPT	385	DS-DE 10-S/9/16-18UNF	445
DS-CSSE 6-L	513	DS-D 12-ML	384	DS-DE 12-L/3/4-16UNF	445

Ref.	P.	Ref.	P.	Ref.	P.
DS-DE 12-L/9/16-18UNF	445	DS-DE 42-RL/OA	446	DS-EDKOR 10L/12L	430
DS-DE 12-ML/O	444	DS-DE 6-S/7/16-20UNF	445	DS-EDKOR 10L/12S	430
DS-DE 12-ML/OA	447	DS-DE 8-S/9/16-18UNF	445	DS-EDKOR 10L/14S	430
DS-DE 12-MS/O	444	DS-E 6-L	386	DS-EDKOR 10L/15L	430
DS-DE 12-MS/OA	447	DS-E 6-S	386	DS-EDKOR 10L/16S	430
DS-DE 12-RL/OA	446	DS-E 8-L	386	DS-EDKOR 10S/10L	430
DS-DE 12-RS/OA	446	DS-E 8-S	386	DS-EDKOR 10S/12L	430
DS-DE 12-S/3/4-16UNF	445	DS-E 10-L	386	DS-EDKOR 10S/12S	430
DS-DE 15-L/3/4-16UNF	445	DS-E 10-S	386	DS-EDKOR 12L/14S	430
DS-DE 15-L/7/8-14UNF	445	DS-E 12-L	386	DS-EDKOR 12L/15L	430
DS-DE 15-ML/O	444	DS-E 12-S	386	DS-EDKOR 12L/16S	430
DS-DE 15-ML/OA	447	DS-E 14-S	386	DS-EDKOR 12L/18L	430
DS-DE 15-RL/OA	446	DS-E 15-L	386	DS-EDKOR 12L/20S	430
DS-DE 16-MS/O	444	DS-E 16-S	386	DS-EDKOR 12S/12L	430
DS-DE 16-MS/OA	447	DS-E 18-L	386	DS-EDKOR 12S/14S	430
DS-DE 16-RS/OA	446	DS-E 20-S	386	DS-EDKOR 12S/15L	430
DS-DE 16-S/7/8-14UNF	445	DS-E 22-L	386	DS-EDKOR 12S/16S	430
DS-DE 18-L/1 1/6-12UN	445	DS-E 25-S	386	DS-EDKOR 14S/16S	430
DS-DE 18-L/7/8-14UNF	445	DS-E 28-L	386	DS-EDKOR 15L/16S	431
DS-DE 18-ML/O	444	DS-E 30-S	386	DS-EDKOR 15L/18L	431
DS-DE 18-ML/OA	447	DS-E 35-L	386	DS-EDKOR 15L/20S	431
DS-DE 18-RL/OA	446	DS-E 38-S	386	DS-EDKOR 15L/22L	431
DS-DE 20-MS/O	444	DS-E 42-L	386	DS-EDKOR 15L/25S	431
DS-DE 20-MS/OA	447	DS-EDKO 6-L	429	DS-EDKOR 16S/18L	431
DS-DE 20-RS/OA	446	DS-EDKO 6-S	429	DS-EDKOR 16S/20S	431
DS-DE 20-S/1 1/16-12UN	445	DS-EDKO 8-L	429	DS-EDKOR 16S/22L	431
DS-DE 22-L/1 1/6-12UN	445	DS-EDKO 8-S	429	DS-EDKOR 16S/25S	431
DS-DE 22-ML/O	444	DS-EDKO 10-L	429	DS-EDKOR 18L/20S	431
DS-DE 22-ML/OA	447	DS-EDKO 10-S	429	DS-EDKOR 18L/22L	431
DS-DE 22-RL/OA	446	DS-EDKO 12-L	429	DS-EDKOR 18L/25S	431
DS-DE 25-MS/O	444	DS-EDKO 12-S	429	DS-EDKOR 18L/28L	431
DS-DE 25-MS/OA	447	DS-EDKO 14-S	429	DS-EDKOR 18L/30S	431
DS-DE 25-RS/OA	446	DS-EDKO 15-L	429	DS-EDKOR 20S/22L	431
DS-DE 25-S/1 1/16-12UN	445	DS-EDKO 16-S	429	DS-EDKOR 20S/25S	431
DS-DE 28-L/1 5/16-12UN	445	DS-EDKO 18-L	429	DS-EDKOR 20S/28L	431
DS-DE 28-ML/O	444	DS-EDKO 20-S	429	DS-EDKOR 20S/30S	431
DS-DE 28-ML/OA	447	DS-EDKO 22-L	429	DS-EDKOR 22L/25S	431
DS-DE 28-RL/OA	446	DS-EDKO 25-S	429	DS-EDKOR 22L/28L	431
DS-DE 30-MS/O	444	DS-EDKO 28-L	429	DS-EDKOR 22L/30S	431
DS-DE 30-MS/OA	447	DS-EDKO 30-S	429	DS-EDKOR 22L/35L	431
DS-DE 30-RS/OA	446	DS-EDKO 35-L	429	DS-EDKOR 22L/38S	431
DS-DE 30-S/1 5/8-12UN	445	DS-EDKO 38-S	429	DS-EDKOR 25S/28L	431
DS-DE 35-L/1 5/8-12UN	445	DS-EDKO 42-L	429	DS-EDKOR 25S/30S	431
DS-DE 35-ML/O	444	DS-EDKOR 6L/6S	430	DS-EDKOR 25S/35L	431
DS-DE 35-ML/OA	447	DS-EDKOR 6L/8L	430	DS-EDKOR 25S/38S	431
DS-DE 35-RL/OA	446	DS-EDKOR 6L/8S	430	DS-EDKOR 28L/30S	431
DS-DE 38-MS/O	444	DS-EDKOR 6L/10L	430	DS-EDKOR 28L/35L	431
DS-DE 38-MS/OA	447	DS-EDKOR 6L/10S	430	DS-EDKOR 28L/38S	431
DS-DE 38-RS/OA	446	DS-EDKOR 8L/8S	430	DS-EDKOR 28L/42L	431
DS-DE 38-S/1 7/8-12UN	445	DS-EDKOR 8L/10L	430	DS-EDKOR 30S/35L	431
DS-DE 42-L/1 7/8-12UN	445	DS-EDKOR 8L/10S	430	DS-EDKOR 30S/38S	431
DS-DE 42-ML/O	444	DS-EDKOR 8L/12L	430	DS-EDKOR 30S/42L	431
DS-DE 42-ML/OA	447	DS-EDKOR 8L/12S	430	DS-EDKOR 35L/38S	431

PRODUCT INDEX

INTEGRATED FLUID POWER SOLUTIONS

Ref.	P.	Ref.	P.	Ref.	P.
DS-EDKOR 35L/42L	431	DS-F 28-L	388	DS-GR 16/8/16-S	391
DS-EDKOR 38S/42L	431	DS-F 30-S	388	DS-GR 16/10/16-S	391
DS-ER 8/ 6-L	387	DS-F 35-L	388	DS-GR 16/12/16-S	391
DS-ER 8/ 6-S	387	DS-F 38-S	388	DS-GR 16/20/16-S	391
DS-ER 10/ 6-L	387	DS-F 42-L	388	DS-GR 18/10/10-L	390
DS-ER 10/ 6-S	387	DS-G 6-L	389	DS-GR 18/10/18-L	390
DS-ER 10/ 8-L	387	DS-G 6-S	389	DS-GR 18/12/18-L	390
DS-ER 10/ 8-S	387	DS-G 8-L	389	DS-GR 18/15/18-L	390
DS-ER 12/ 6-L	387	DS-G 8-S	389	DS-GR 18/18/10-L	390
DS-ER 12/ 6-S	387	DS-G 10-L	389	DS-GR 20/10/20-S	391
DS-ER 12/ 8-L	387	DS-G 10-S	389	DS-GR 20/12/20-S	391
DS-ER 12/ 8-S	387	DS-G 12-L	389	DS-GR 20/16/20-S	391
DS-ER 12/10-L	387	DS-G 12-S	389	DS-GR 20/25/20-S	391
DS-ER 12/10-S	387	DS-G 14-S	389	DS-GR 22/10/22-L	390
DS-ER 14/10-S	387	DS-G 15-L	389	DS-GR 22/12/22-L	390
DS-ER 14/12-S	387	DS-G 16-S	389	DS-GR 22/15/15-L	390
DS-ER 15/10-L	387	DS-G 18-L	389	DS-GR 22/15/22-L	390
DS-ER 15/12-L	387	DS-G 20-S	389	DS-GR 22/18/18-L	390
DS-ER 16/12-S	387	DS-G 22-L	389	DS-GR 22/18/22-L	390
DS-ER 16/14-S	387	DS-G 25-S	389	DS-GR 22/22/18-L	390
DS-ER 18/10-L	387	DS-G 28-L	389	DS-GR 25/16/25-S	391
DS-ER 18/12-L	387	DS-G 30-S	389	DS-GR 25/20/25-S	391
DS-ER 18/15-L	387	DS-G 35-L	389	DS-GR 25/30/25-S	391
DS-ER 20/10-S	387	DS-G 38-S	389	DS-GR 28/10/28-L	390
DS-ER 20/12-S	387	DS-G 42-L	389	DS-GR 28/12/28-L	390
DS-ER 20/16-S	387	DS-GR 6/8/6-L	390	DS-GR 28/15/28-L	390
DS-ER 22/12-L	387	DS-GR 6/10/6-L	390	DS-GR 28/18/28-L	391
DS-ER 22/15-L	387	DS-GR 8/6/8-L	390	DS-GR 28/22/22-L	391
DS-ER 22/18-L	387	DS-GR 8/10/8-L	390	DS-GR 28/22/28-L	391
DS-ER 25/16-S	387	DS-GR 8/12/8-L	390	DS-H 6-L	392
DS-ER 25/20-S	387	DS-GR 10/6/10-L	390	DS-H 6-S	392
DS-ER 28/18-L	387	DS-GR 10/6/10-S	391	DS-H 8-L	392
DS-ER 28/22-L	387	DS-GR 10/8/10-L	390	DS-H 8-S	392
DS-ER 30/20-S	387	DS-GR 10/10/ 6-L	390	DS-H 10-L	392
DS-ER 30/25-S	387	DS-GR 10/15/10-L	390	DS-H 10-S	392
DS-ER 35/22-L	387	DS-GR 12/6/12-L	390	DS-H 12-L	392
DS-ER 35/28-L	387	DS-GR 12/8/8-L	390	DS-H 12-S	392
DS-ER 38/30-S	387	DS-GR 12/8/8-S	391	DS-H 14-S	392
DS-F 6-L	388	DS-GR 12/8/12-L	390	DS-H 15-L	392
DS-F 6-S	388	DS-GR 12/8/12-S	391	DS-H 16-S	392
DS-F 8-L	388	DS-GR 12/10/10-L	390	DS-H 18-L	392
DS-F 8-S	388	DS-GR 12/10/12-L	390	DS-H 20-S	392
DS-F 10 L	388	DS-GR 12/10/12-S	391	DS-H 22-L	392
DS-F 10-S	388	DS-GR 12/12/10-L	390	DS-H 25-S	392
DS-F 12-L	388	DS-GR 12/15/12-L	390	DS-H 28-L	392
DS-F 12-S	388	DS-GR 12/16/12-S	391	DS-H 30-S	392
DS-F 14-S	388	DS-GR 12/18/12-L	390	DS-H 35-L	392
DS-F 15-L	388	DS-GR 15/ 6/15-L	390	DS-H 38-S	392
DS-F 16-S	388	DS-GR 15/10/15-L	390	DS-H 42-L	392
DS-F 18-L	388	DS-GR 15/12/12-L	390	DS-K 6-L	393
DS-F 20-S	388	DS-GR 15/12/15-L	390	DS-K 6-S	393
DS-F 22-L	388	DS-GR 15/15/12-L	390	DS-K 8-L	393
DS-F 25-S	388	DS-GR 16/6/16-S	391	DS-K 8-S	393

Ref.	P.	Ref.	P.	Ref.	P.
DS-K 10-L	393	DS-N 35-L	395	DS-RL 28/8	456
DS-K 10-S	393	DS-N 38-S	395	DS-RL 28/10	456
DS-K 12-L	393	DS-N 42-L	395	DS-RL 28/12	456
DS-K 12-S	393	DS-O 10-L	450	DS-RL 28/15	456
DS-K 14-S	393	DS-O 10-S	450	DS-RL 28/18	456
DS-K 15-L	393	DS-O 12-L	450	DS-RL 28/22	456
DS-K 16-S	393	DS-O 12-S	450	DS-RL 35/6	456
DS-K 18-L	393	DS-O 6-L	450	DS-RL 35/8	456
DS-K 20-S	393	DS-O 6-S	450	DS-RL 35/10	456
DS-K 22-L	393	DS-O 8-L	450	DS-RL 35/12	456
DS-K 25-S	393	DS-O 8-S	450	DS-RL 35/15	456
DS-K 28-L	393	DS-RD 10-L	463	DS-RL 35/18	456
DS-K 30-S	393	DS-RD 10-S	463	DS-RL 35/22	456
DS-K 35-L	393	DS-RD 12-L	463	DS-RL 35/28	456
DS-K 38-S	393	DS-RD 12-S	463	DS-RL 42/ 6	456
DS-K 42-L	393	DS-RD 14-S	463	DS-RL 42/ 8	456
DS-L 6-L	394	DS-RD 15-L	463	DS-RL 42/10	456
DS-L 6-S	394	DS-RD 16-S	463	DS-RL 42/12	456
DS-L 8-L	394	DS-RD 18-L	463	DS-RL 42/15	456
DS-L 8-S	394	DS-RD 20-S	463	DS-RL 42/18	456
DS-L 10-L	394	DS-RD 22-L	463	DS-RL 42/22	456
DS-L 10-S	394	DS-RD 25-S	463	DS-RL 42/28	456
DS-L 12-L	394	DS-RD 28-L	463	DS-RL 42/35	456
DS-L 12-S	394	DS-RD 30-S	463	DS-RLDKO 8/6	458
DS-L 14-S	394	DS-RD 35-L	463	DS-RLDKO 10/6	458
DS-L 15-L	394	DS-RD 38-S	463	DS-RLDKO 10/8	458
DS-L 16-S	394	DS-RD 42-L	463	DS-RLDKO 12/6	458
DS-L 18-L	394	DS-RD 6-L	463	DS-RLDKO 12/8	458
DS-L 20-S	394	DS-RD 6-S	463	DS-RLDKO 12/10	458
DS-L 22-L	394	DS-RD 8-L	463	DS-RLDKO 15/6	458
DS-L 25-S	394	DS-RD 8-S	463	DS-RLDKO 15/8	458
DS-L 28-L	394	DS-RL 8/6	456	DS-RLDKO 15/10	458
DS-L 30-S	394	DS-RL 10/6	456	DS-RLDKO 15/12	458
DS-L 35-L	394	DS-RL 10/8	456	DS-RLDKO 18/6	458
DS-L 38-S	394	DS-RL 12/6	456	DS-RLDKO 18/8	458
DS-L 42-L	394	DS-RL 12/8	456	DS-RLDKO 18/10	458
DS-N 6-L	395	DS-RL 12/10	456	DS-RLDKO 18/12	458
DS-N 6-S	395	DS-RL 15/6	456	DS-RLDKO 18/15	458
DS-N 8-L	395	DS-RL 15/8	456	DS-RLDKO 22/6	458
DS-N 8-S	395	DS-RL 15/10	456	DS-RLDKO 22/8	458
DS-N 10-L	395	DS-RL 15/12	456	DS-RLDKO 22/10	458
DS-N 10-S	395	DS-RL 18/6	456	DS-RLDKO 22/12	458
DS-N 12-L	395	DS-RL 18/8	456	DS-RLDKO 22/15	458
DS-N 12-S	395	DS-RL 18/10	456	DS-RLDKO 22/18	458
DS-N 14-S	395	DS-RL 18/12	456	DS-RLDKO 28/6	458
DS-N 15-L	395	DS-RL 18/15	456	DS-RLDKO 28/8	458
DS-N 16-S	395	DS-RL 22/6	456	DS-RLDKO 28/10	458
DS-N 18-L	395	DS-RL 22/8	456	DS-RLDKO 28/12	458
DS-N 20-S	395	DS-RL 22/10	456	DS-RLDKO 28/15	458
DS-N 22-L	395	DS-RL 22/12	456	DS-RLDKO 28/18	458
DS-N 25-S	395	DS-RL 22/15	456	DS-RLDKO 28/22	458
DS-N 28-L	395	DS-RL 22/18	456	DS-RLDKO 35/6	458
DS-N 30-S	395	DS-RL 28/6	456	DS-RLDKO 35/8	458

PRODUCT INDEX

INTEGRATED FLUID POWER SOLUTIONS

Ref.	P.	Ref.	P.	Ref.	P.
DS-RLDKO 35/10	458	DS-RS 38/10	457	DS-RV 10-MS/WD	465
DS-RLDKO 35/12	458	DS-RS 38/12	457	DS-RV 10-RL/WD	464
DS-RLDKO 35/15	458	DS-RS 38/14	457	DS-RV 10-RS/WD	464
DS-RLDKO 35/18	458	DS-RS 38/16	457	DS-RV 12-ML/WD	465
DS-RLDKO 35/22	458	DS-RS 38/20	457	DS-RV 12-MS/WD	465
DS-RLDKO 35/28	458	DS-RS 38/25	457	DS-RV 12-RL/WD	464
DS-RLDKO 42/6	458	DS-RS 38/30	457	DS-RV 12-RS/WD	464
DS-RLDKO 42/8	458	DS-RSDKO 8/6	459	DS-RV 14-MS/WD	465
DS-RLDKO 42/10	458	DS-RSDKO 10/6	459	DS-RV 14-RS/WD	464
DS-RLDKO 42/12	458	DS-RSDKO 10/8	459	DS-RV 15-ML/WD	465
DS-RLDKO 42/15	458	DS-RSDKO 12/6	459	DS-RV 15-RL/WD	464
DS-RLDKO 42/18	458	DS-RSDKO 12/8	459	DS-RV 16-MS/WD	465
DS-RLDKO 42/22	458	DS-RSDKO 12/10	459	DS-RV 16-RS/WD	464
DS-RLDKO 42/28	458	DS-RSDKO 14/ 6	459	DS-RV 18-ML/WD	465
DS-RLDKO 42/35	458	DS-RSDKO 14/ 8	459	DS-RV 18-RL/WD	464
DS-RS 8/6	457	DS-RSDKO 14/10	459	DS-RV 20-MS/WD	465
DS-RS 10/6	457	DS-RSDKO 14/12	459	DS-RV 20-RS/WD	464
DS-RS 10/8	457	DS-RSDKO 16/ 6	459	DS-RV 22-ML/WD	465
DS-RS 12/6	457	DS-RSDKO 16/ 8	459	DS-RV 22-RL/WD	464
DS-RS 12/8	457	DS-RSDKO 16/10	459	DS-RV 25-MS/WD	465
DS-RS 12/10	457	DS-RSDKO 16/12	459	DS-RV 25-RS/WD	464
DS-RS 14/6	457	DS-RSDKO 16/14	459	DS-RV 28-ML/WD	465
DS-RS 14/8	457	DS-RSDKO 20/6	459	DS-RV 28-RL/WD	464
DS-RS 14/10	457	DS-RSDKO 20/8	459	DS-RV 30-MS/WD	465
DS-RS 14/12	457	DS-RSDKO 20/10	459	DS-RV 30-RS/WD	464
DS-RS 16/6	457	DS-RSDKO 20/12	459	DS-RV 35-ML/WD	465
DS-RS 16/8	457	DS-RSDKO 20/14	459	DS-RV 35-RL/WD	464
DS-RS 16/10	457	DS-RSDKO 20/16	459	DS-RV 38-MS/WD	465
DS-RS 16/12	457	DS-RSDKO 25/6	459	DS-RV 38-RS/WD	464
DS-RS 16/14	457	DS-RSDKO 25/8	459	DS-RV 42-ML/WD	465
DS-RS 20/6	457	DS-RSDKO 25/10	459	DS-RV 42-RL/WD	464
DS-RS 20/8	457	DS-RSDKO 25/12	459	DS-RV 6-ML/WD	465
DS-RS 20/10	457	DS-RSDKO 25/14	459	DS-RV 6-MS/WD	465
DS-RS 20/12	457	DS-RSDKO 25/16	459	DS-RV 6-RL/WD	464
DS-RS 20/14	457	DS-RSDKO 25/20	459	DS-RV 6-RS/WD	464
DS-RS 20/16	457	DS-RSDKO 30/6	459	DS-RV 8-ML/WD	465
DS-RS 25/6	457	DS-RSDKO 30/8	459	DS-RV 8-MS/WD	465
DS-RS 25/8	457	DS-RSDKO 30/10	459	DS-RV 8-RL/WD	464
DS-RS 25/10	457	DS-RSDKO 30/12	459	DS-RV 8-RS/WD	464
DS-RS 25/12	457	DS-RSDKO 30/14	459	DS-RZ 10-ML/WD	467
DS-RS 25/14	457	DS-RSDKO 30/16	459	DS-RZ 10-MS/WD	467
DS-RS 25/16	457	DS-RSDKO 30/20	459	DS-RZ 10-RL/WD	466
DS-RS 25/20	457	DS-RSDKO 30/25	459	DS-RZ 10-RS/WD	466
DS-RS 30/6	457	DS-RSDKO 38/6	459	DS-RZ 12-ML/WD	467
DS-RS 30/8	457	DS-RSDKO 38/8	459	DS-RZ 12-MS/WD	467
DS-RS 30/10	457	DS-RSDKO 38/10	459	DS-RZ 12-RL/WD	466
DS-RS 30/12	457	DS-RSDKO 38/12	459	DS-RZ 12-RS/WD	466
DS-RS 30/14	457	DS-RSDKO 38/14	459	DS-RZ 14-MS/WD	467
DS-RS 30/16	457	DS-RSDKO 38/16	459	DS-RZ 14-RS/WD	466
DS-RS 30/20	457	DS-RSDKO 38/20	459	DS-RZ 15-ML/WD	467
DS-RS 30/25	457	DS-RSDKO 38/25	459	DS-RZ 15-RL/WD	466
DS-RS 38/6	457	DS-RSDKO 38/30	459	DS-RZ 16-MS/WD	467
DS-RS 38/8	457	DS-RV 10-ML/WD	465	DS-RZ 16-RS/WD	466

Ref.	P.	Ref.	P.	Ref.	P.
DS-RZ 18-ML/WD	467	DS-SB 22-RL	404	DS-SBD 16-RS	400
DS-RZ 18-RL/WD	466	DS-SB 25-MS	405	DS-SBD 16-RS	402
DS-RZ 20-MS/WD	467	DS-SB 25-RS	404	DS-SBD 18-ML	401
DS-RZ 20-RS/WD	466	DS-SB 28-ML	405	DS-SBD 18-ML	403
DS-RZ 22-ML/WD	467	DS-SB 28-RL	404	DS-SBD 18-RL	400
DS-RZ 22-RL/WD	466	DS-SB 30-MS	405	DS-SBD 18-RL	402
DS-RZ 25-MS/WD	467	DS-SB 30-RS	404	DS-SBD 20-MS	401
DS-RZ 25-RS/WD	466	DS-SB 35-ML	405	DS-SBD 20-MS	403
DS-RZ 28-ML/WD	467	DS-SB 35-RL	404	DS-SBD 20-RS	400
DS-RZ 28-RL/WD	466	DS-SB 38-MS	405	DS-SBD 20-RS	402
DS-RZ 30-MS/WD	467	DS-SB 38-RS	404	DS-SBD 22-ML	401
DS-RZ 30-RS/WD	466	DS-SB 42-ML	405	DS-SBD 22-ML	403
DS-RZ 35-ML/WD	467	DS-SB 42-RL	404	DS-SBD 22-RL	400
DS-RZ 35-RL/WD	466	DS-SBD 6-ML	401	DS-SBD 22-RL	402
DS-RZ 38-MS/WD	467	DS-SBD 6-MS	401	DS-SBE 6-ML	409
DS-RZ 38-RS/WD	466	DS-SBD 6-RL	400	DS-SBE 6-ML/EDE	410
DS-RZ 42-ML/WD	467	DS-SBD 6-RL	402	DS-SBE 6-MS	409
DS-RZ 42-RL/WD	466	DS-SBD 6-RS	400	DS-SBE 6-MS/EDE	410
DS-RZ 6-ML/WD	467	DS-SBD 6-RS	402	DS-SBE 6-RL	406
DS-RZ 6-MS/WD	467	DS-SBD 8-ML	401	DS-SBE 6-RL/EDE	407
DS-RZ 6-RL/WD	466	DS-SBD 8-ML	403	DS-SBE 6-RL/KDE	408
DS-RZ 6-RS/WD	648	DS-SBD 8-MS	401	DS-SBE 6-RS	406
DS-RZ 8-ML/WD	467	DS-SBD 8-MS	403	DS-SBE 6-RS/EDE	407
DS-RZ 8-MS/WD	467	DS-SBD 8-RL	400	DS-SBE 6-RS/KDE	408
DS-RZ 8-RL/WD	466	DS-SBD 8-RL	402	DS-SBE 8-ML	409
DS-RZ 8-RS/WD	466	DS-SBD 8-RS	400	DS-SBE 8-ML/EDE	410
DS-SB 6-ML	405	DS-SBD 8-RS	402	DS-SBE 8-MS	409
DS-SB 6-MS	405	DS-SBD 10-ML	401	DS-SBE 8-MS/EDE	410
DS-SB 6-RL	404	DS-SBD 10-ML	403	DS-SBE 8-RL	406
DS-SB 6-RS	404	DS-SBD 10-MS	401	DS-SBE 8-RL/EDE	407
DS-SB 8-ML	405	DS-SBD 10-MS	403	DS-SBE 8-RL/KDE	408
DS-SB 8-MS	405	DS-SBD 10-RL	400	DS-SBE 8-RS	406
DS-SB 8-RL	404	DS-SBD 10-RL	402	DS-SBE 8-RS/EDE	407
DS-SB 8-RS	404	DS-SBD 10-RS	400	DS-SBE 8-RS/KDE	408
DS-SB 10-ML	405	DS-SBD 10-RS	402	DS-SBE 10-ML	409
DS-SB 10-MS	405	DS-SBD 12-ML	401	DS-SBE 10-ML/EDE	410
DS-SB 10-RL	404	DS-SBD 12-ML	403	DS-SBE 10-ML/KDE	411
DS-SB 10-RS	404	DS-SBD 12-MS	401	DS-SBE 10-MS	409
DS-SB 12-ML	405	DS-SBD 12-MS	403	DS-SBE 10-MS/EDE	410
DS-SB 12-MS	405	DS-SBD 12-RL	400	DS-SBE 10-MS/KDE	411
DS-SB 12-RL	404	DS-SBD 12-RL	402	DS-SBE 10-RL	406
DS-SB 12-RS	404	DS-SBD 12-RS	400	DS-SBE 10-RL/EDE	407
DS-SB 14-MS	405	DS-SBD 12-RS	402	DS-SBE 10-RL/KDE	408
DS-SB 14-RS	404	DS-SBD 14-MS	401	DS-SBE 10-RS	406
DS-SB 15-ML	405	DS-SBD 14-MS	403	DS-SBE 10-RS/EDE	407
DS-SB 15-RL	404	DS-SBD 14-RS	400	DS-SBE 10-RS/KDE	408
DS-SB 16-MS	405	DS-SBD 14-RS	402	DS-SBE 12-ML	409
DS-SB 16-RS	404	DS-SBD 15-ML	401	DS-SBE 12-ML/EDE	410
DS-SB 18-ML	405	DS-SBD 15-ML	403	DS-SBE 12-ML/KDE	411
DS-SB 18-RL	404	DS-SBD 15-RL	400	DS-SBE 12-MS	409
DS-SB 20-MS	405	DS-SBD 15-RL	402	DS-SBE 12-MS/EDE	410
DS-SB 20-RS	404	DS-SBD 16-MS	401	DS-SBE 12-MS/KDE	411
DS-SB 22-ML	405	DS-SBD 16-MS	403	DS-SBE 12-RL	406

PRODUCT INDEX

INTEGRATED FLUID POWER SOLUTIONS

Ref.	P.	Ref.	P.	Ref.	P.
DS-SBE 12-RL/EDE	407	DS-SBE 30-MS/KDE	411	DS-SGE 15-ML	414
DS-SBE 12-RL/KDE	408	DS-SBE 30-RS	406	DS-SGE 15-ML/EDE	415
DS-SBE 12-RS	406	DS-SBE 30-RS/EDE	407	DS-SGE 15-RL	412
DS-SBE 12-RS/EDE	407	DS-SBE 30-RS/KDE	408	DS-SGE 15-RL/EDE	413
DS-SBE 12-RS/KDE	408	DS-SBE 35-ML	409	DS-SGE 16-MS	414
DS-SBE 14-MS	409	DS-SBE 35-ML/EDE	410	DS-SGE 16-MS/EDE	415
DS-SBE 14-RS	406	DS-SBE 35-ML/KDE	411	DS-SGE 16-RS	412
DS-SBE 14-RS/EDE	407	DS-SBE 35-RL	406	DS-SGE 16-RS/EDE	413
DS-SBE 14-RS/KDE	408	DS-SBE 35-RL/EDE	407	DS-SGE 18-ML	414
DS-SBE 15-ML	409	DS-SBE 35-RL/KDE	408	DS-SGE 18-ML/EDE	415
DS-SBE 15-ML/EDE	410	DS-SBE 38-MS	409	DS-SGE 18-RL	412
DS-SBE 15-ML/KDE	411	DS-SBE 38-MS/EDE	410	DS-SGE 18-RL/EDE	413
DS-SBE 15-RL	406	DS-SBE 38-MS/KDE	411	DS-SGE 20-MS	414
DS-SBE 15-RL/EDE	407	DS-SBE 38-RS	406	DS-SGE 20-MS/EDE	415
DS-SBE 15-RL/KDE	408	DS-SBE 38-RS/EDE	407	DS-SGE 20-RS	412
DS-SBE 16-MS	409	DS-SBE 38-RS/KDE	408	DS-SGE 20-RS/EDE	413
DS-SBE 16-MS/EDE	410	DS-SBE 42-ML	409	DS-SGE 22-ML	415
DS-SBE 16-MS/KDE	411	DS-SBE 42-ML/EDE	410	DS-SGE 22-ML/EDE	414
DS-SBE 16-RS	406	DS-SBE 42-ML/KDE	411	DS-SGE 22-RL	412
DS-SBE 16-RS/EDE	407	DS-SBE 42-RL	406	DS-SGE 22-RL/EDE	413
DS-SBE 16-RS/KDE	408	DS-SBE 42-RL/EDE	407	DS-SGE 25-MS	414
DS-SBE 18-ML	409	DS-SBE 42-RL/KDE	408	DS-SGE 25-MS/EDE	415
DS-SBE 18-ML/EDE	410	DS-SBE 6-ML/KDE	411	DS-SGE 25-RS	412
DS-SBE 18-ML/KDE	411	DS-SBE 6-MS/KDE	411	DS-SGE 25-RS/EDE	413
DS-SBE 18-RL	406	DS-SBE 8-ML/KDE	411	DS-SGE 28-ML	415
DS-SBE 18-RL/EDE	407	DS-SBE 8-MS/KDE	411	DS-SGE 28-ML/EDE	415
DS-SBE 18-RL/KDE	408	DS-SGE 6-ML	414	DS-SGE 28-RL	412
DS-SBE 20-MS	409	DS-SGE 6-ML/EDE	415	DS-SGE 28-RL/EDE	413
DS-SBE 20-MS/EDE	410	DS-SGE 6-MS	414	DS-SGE 30-MS	414
DS-SBE 20-MS/KDE	411	DS-SGE 6-MS/EDE	415	DS-SGE 30-MS/EDE	415
DS-SBE 20-RS	406	DS-SGE 8-ML	414	DS-SGE 30-RS	412
DS-SBE 20-RS/EDE	407	DS-SGE 8-ML/EDE	415	DS-SGE 30-RS/EDE	413
DS-SBE 20-RS/KDE	408	DS-SGE 8-MS	414	DS-SGE 35-ML	414
DS-SBE 22-ML	409	DS-SGE 8-MS/EDE	415	DS-SGE 35-ML/EDE	415
DS-SBE 22-ML/EDE	410	DS-SGE 10-ML	414	DS-SGE 35-RL	412
DS-SBE 22-ML/KDE	411	DS-SGE 10-ML/EDE	415	DS-SGE 35-RL/EDE	413
DS-SBE 22-RL	406	DS-SGE 10-MS	414	DS-SGE 38-MS	414
DS-SBE 22-RL/EDE	407	DS-SGE 10-MS/EDE	415	DS-SGE 38-MS/EDE	415
DS-SBE 22-RL/KDE	408	DS-SGE 10-RL	412	DS-SGE 38-RS	412
DS-SBE 25-MS	409	DS-SGE 10-RL/EDE	413	DS-SGE 38-RS/EDE	413
DS-SBE 25-MS/EDE	410	DS-SGE 10-RS	412	DS-SGE 42-ML	414
DS-SBE 25-MS/KDE	411	DS-SGE 10-RS/EDE	413	DS-SGE 42-ML/EDE	415
DS-SBE 25-RS	406	DS-SGE 12-ML	414	DS-SGE 42-RL	412
DS-SBE 25-RS/EDE	407	DS-SGE 12-ML/EDE	415	DS-SGE 42-RL/EDE	413
DS-SBE 25-RS/KDE	408	DS-SGE 12-MS	414	DS-SGE 6-RL	412
DS-SBE 28-ML	409	DS-SGE 12-MS/EDE	415	DS-SGE 6-RL/EDE	413
DS-SBE 28-ML/EDE	410	DS-SGE 12-RL	412	DS-SGE 6-RS	412
DS-SBE 28-ML/KDE	411	DS-SGE 12-RL/EDE	413	DS-SGE 6-RS/EDE	413
DS-SBE 28-RL	406	DS-SGE 12-RS	412	DS-SGE 8-RL	412
DS-SBE 28-RL/EDE	407	DS-SGE 12-RS/EDE	413	DS-SGE 8-RL/EDE	413
DS-SBE 28-RL/KDE	408	DS-SGE 14-MS	414	DS-SGE 8-RS	412
DS-SBE 30-MS	409	DS-SGE 14-RS	415	DS-SGE 8-RS/EDE	413
DS-SBE 30-MS/EDE	410	DS-SGE 14-RS/EDE	413	DS-V 6-L	396

Ref.	P.	Ref.	P.	Ref.	P.
DS-V 6-S	396	DS-VA 16-S/R 3/4"/WD	423	DS-VADKO 22-RL/WD	426
DS-V 8-L	396	DS-VA 18-L/NPT	425	DS-VADKO 25-MS/WD	427
DS-V 8-S	396	DS-VA 18-ML/WD	424	DS-VADKO 25-RS/WD	426
DS-V 10-L	396	DS-VA 18-RL/WD	423	DS-VADKO 28-ML/WD	427
DS-V 10-S	396	DS-VA 20-MS/WD	424	DS-VADKO 28-RL/WD	426
DS-V 12-L	396	DS-VA 20-RS/WD	423	DS-VADKO 30-MS/WD	427
DS-V 12-S	396	DS-VA 20-S/NPT	425	DS-VADKO 30-RS/WD	426
DS-V 14-S	396	DS-VA 22-L/NPT	425	DS-VADKO 35-ML/WD	427
DS-V 15-L	396	DS-VA 22-ML/WD	424	DS-VADKO 35-RL/WD	426
DS-V 16-S	396	DS-VA 22-RL/WD	423	DS-VADKO 38-MS/WD	427
DS-V 18-L	396	DS-VA 25-MS/WD	424	DS-VADKO 38-RS/WD	426
DS-V 20-S	396	DS-VA 25-RS/WD	423	DS-VADKO 42-ML/WD	427
DS-V 22-L	396	DS-VA 25-S/NPT	425	DS-VADKO 42-RL/WD	426
DS-V 25-S	396	DS-VA 28-L/NPT	425	DS-VADKO 6-RL/WD	426
DS-V 28-L	396	DS-VA 28-ML/WD	424	DS-VADKO 6-RS/WD	426
DS-V 30-S	396	DS-VA 28-RL/WD	423	DS-VADKO 8-RL/WD	426
DS-V 35-L	396	DS-VA 30-MS/WD	424	DS-VADKO 8-RS/WD	426
DS-V 38-S	396	DS-VA 30-RS/WD	423	DS-VB 6-L	416
DS-V 42-L	396	DS-VA 30-S/NPT	425	DS-VB 6-S	416
DS-VA 6-L/NPT	425	DS-VA 35-L/NPT	425	DS-VB 8-L	416
DS-VA 6-ML/WD	424	DS-VA 35-ML/WD	424	DS-VB 8-S	416
DS-VA 6-MS/WD	424	DS-VA 35-RL/WD	423	DS-VB 10-L	416
DS-VA 6-RL/WD	423	DS-VA 38-MS/WD	424	DS-VB 10-S	416
DS-VA 6-RS/WD	423	DS-VA 38-RS/WD	423	DS-VB 12-L	416
DS-VA 6-S/NPT	425	DS-VA 38-S/NPT	425	DS-VB 12-S	416
DS-VA 8-L/NPT	425	DS-VA 42-L/NPT	425	DS-VB 14-S	416
DS-VA 8-ML/WD	424	DS-VA 42-ML/WD	424	DS-VB 15-L	416
DS-VA 8-MS/WD	424	DS-VA 42-RL/WD	423	DS-VB 16-S	416
DS-VA 8-RL/WD	423	DS-VADKO 6-ML/WD	427	DS-VB 18-L	416
DS-VA 8-RS/WD	423	DS-VADKO 6-MS/WD	427	DS-VB 20-S	416
DS-VA 8-S/NPT	425	DS-VADKO 8-ML/WD	427	DS-VB 22-L	416
DS-VA 10-L/NPT	425	DS-VADKO 8-MS/WD	427	DS-VB 25-S	416
DS-VA 10-ML/WD	424	DS-VADKO 10-ML/WD	427	DS-VB 28-L	416
DS-VA 10-MS/WD	424	DS-VADKO 10-MS/WD	427	DS-VB 30-S	416
DS-VA 10-RL/WD	423	DS-VADKO 10-RL/WD	426	DS-VB 35-L	416
DS-VA 10-RS/WD	423	DS-VADKO 10-RS/WD	426	DS-VB 38-S	416
DS-VA 10-S/NPT	425	DS-VADKO 12-ML/WD	427	DS-VB 42-L	416
DS-VA 12-L/NPT	425	DS-VADKO 12-MS/WD	427	DS-VBDKO 6-L	419
DS-VA 12-ML/WD	424	DS-VADKO 12-RL/R1/4"/WD	426	DS-VBDKO 6-S	419
DS-VA 12-MS/WD	424	DS-VADKO 12-RL/WD	426	DS-VBDKO 8-L	419
DS-VA 12-RL/WD	423	DS-VADKO 12-RS/WD	426	DS-VBDKO 8-S	419
DS-VA 12-RS/WD	423	DS-VADKO 12-S/R1/2"/WD	426	DS-VBDKO 10-L	419
DS-VA 12-S/NPT	425	DS-VADKO 14-MS/WD	427	DS-VBDKO 10-S	419
DS-VA 12-S/R 1/2"/WD	423	DS-VADKO 14-RS/WD	426	DS-VBDKO 12-L	419
DS-VA 14-MS/WD	424	DS-VADKO 15-ML/WD	427	DS-VBDKO 12-S	419
DS-VA 14-RS/WD	423	DS-VADKO 15-RL/WD	426	DS-VBDKO 14-S	419
DS-VA 14-S/NPT	425	DS-VADKO 16-MS/WD	427	DS-VBDKO 15-L	419
DS-VA 15-L/NPT	425	DS-VADKO 16-RS/WD	426	DS-VBDKO 16-S	419
DS-VA 15-ML/WD	424	DS-VADKO 18-ML/WD	427	DS-VBDKO 18-L	419
DS-VA 15-RL/WD	423	DS-VADKO 18-RL/WD	426	DS-VBDKO 20-S	419
DS-VA 16-MS/WD	424	DS-VADKO 20-MS/WD	427	DS-VBDKO 22-L	419
DS-VA 16-RS/WD	423	DS-VADKO 20-RS/WD	426	DS-VBDKO 25-S	419
DS-VA 16-S/NPT	425	DS-VADKO 22-ML/WD	427	DS-VBDKO 28-L	419

PRODUCT INDEX

INTEGRATED FLUID POWER SOLUTIONS

Ref.	P.	Ref.	P.	Ref.	P.
DS-VBDKO 30-S	419	DS-VD 15-L	418	DS-VSCHK 30-S	477
DS-VBDKO 35-L	419	DS-VD 16-S	418	DS-VSCHK 35-L	477
DS-VBDKO 38-S	419	DS-VD 18-L	418	DS-VSCHK 38-S	477
DS-VBDKO 42-L	419	DS-VD 20-S	418	DS-VSCHK 42-L	477
DS-VC 6-L	417	DS-VD 22-L	418	DS-VSCHK 6-L	477
DS-VC 6-S	417	DS-VD 25-S	418	DS-VSCHK 8-L	477
DS-VC 8-L	417	DS-VD 28-L	418	DSW 10-L/S	473
DS-VC 8-S	417	DS-VD 30-S	418	DSW 12-L/S	473
DS-VC 10-L	417	DS-VD 35-L	418	DSW 14-S	473
DS-VC 10-S	417	DS-VD 38-S	418	DSW 15-L	473
DS-VC 12-L	417	DS-VD 42-L	418	DSW 16-S	473
DS-VC 12-S	417	DS-VDDKO 6-L	422	DSW 18-L	473
DS-VC 14-S	417	DS-VDDKO 6-S	422	DSW 20-S	473
DS-VC 15-L	417	DS-VDDKO 8-L	422	DSW 22-L	473
DS-VC 16-S	417	DS-VDDKO 8-S	422	DSW 25-S	473
DS-VC 18-L	417	DS-VDDKO 10-L	422	DSW 28-L	473
DS-VC 20-S	417	DS-VDDKO 10-S	422	DSW 30-S	473
DS-VC 22-L	417	DS-VDDKO 12-L	422	DSW 35-L	473
DS-VC 25-S	417	DS-VDDKO 12-S	422	DSW 38-S	473
DS-VC 28-L	417	DS-VDDKO 14-S	422	DSW 42-L	473
DS-VC 30-S	417	DS-VDDKO 15-L	422	DSW 6-L/S	473
DS-VC 35-L	417	DS-VDDKO 16-S	422	DSW 8-L/S	473
DS-VC 38-S	417	DS-VDDKO 18-L	422	E 4-LL	386
DS-VC 42-L	417	DS-VDDKO 20-S	422	E 6-LL	386
DS-VCDKO 6-L	421	DS-VDDKO 22-L	422	E 8-LL	386
DS-VCDKO 6-S	421	DS-VDDKO 25-S	422	EDE M 12	484
DS-VCDKO 8-L	421	DS-VDDKO 28-L	422	EDE M 18	484
DS-VCDKO 8-S	421	DS-VDDKO 30-S	422	EDE M 26	484
DS-VCDKO 10-L	421	DS-VDDKO 35-L	422	EDE R 1/2" - M 22	484
DS-VCDKO 10-S	421	DS-VDDKO 38-S	422	EDE R 1/4" - M 14	484
DS-VCDKO 12-L	421	DS-VDDKO 42-L	422	EDE R 1/8" - M 10	484
DS-VCDKO 12-S	421	DS-VODKO 6-L	451	EDE R 3/4" - M 27	484
DS-VCDKO 14-S	421	DS-VODKO 6-S	451	EDE R 3/8" - M 16	484
DS-VCDKO 15-L	421	DS-VODKO 8-L	451	EDE R 1" - M 33	484
DS-VCDKO 16-S	421	DS-VODKO 8-S	451	EDE R 1 1/2" - M 48	484
DS-VCDKO 18-L	421	DS-VODKO 10-L	451	EDE R 1 1/4" - M 42	484
DS-VCDKO 20-S	421	DS-VODKO 10-S	451	ER 6/4-LL	387
DS-VCDKO 22-L	421	DS-VODKO 12-L	451	ER 8/4-LL	387
DS-VCDKO 25-S	421	DS-VODKO 12-S	451	ER 8/6-LL	387
DS-VCDKO 28-L	421	DS-VSCHK 6-S	477	F 4-LL	388
DS-VCDKO 30-S	421	DS-VSCHK 8-S	477	F 6-LL	388
DS-VCDKO 35-L	421	DS-VSCHK 10-L	477	F 8-LL	388
DS-VCDKO 38-S	421	DS-VSCHK 10-S	477	FLAT ARMOUR GUARD ID 0.550"	572
DS-VCDKO 42-L	421	DS-VSCHK 12-L	477	FLAT ARMOUR GUARD ID 0.609"	572
DS-VD 6-L	418	DS-VSCHK 12-S	477	FLAT ARMOUR GUARD ID 0.656"	572
DS-VD 6-S	418	DS-VSCHK 14-S	477	FLAT ARMOUR GUARD ID 0.719"	572
DS-VD 8-L	418	DS-VSCHK 15-L	477	FLAT ARMOUR GUARD ID 0.797"	572
DS-VD 8-S	418	DS-VSCHK 16-S	477	FLAT ARMOUR GUARD ID 0.812"	572
DS-VD 10-L	418	DS-VSCHK 18-L	477	FLAT ARMOUR GUARD ID 0.875"	572
DS-VD 10-S	418	DS-VSCHK 20-S	477	FLAT ARMOUR GUARD ID 0.953"	572
DS-VD 12-L	418	DS-VSCHK 22-L	477	FLAT ARMOUR GUARD ID 1.093"	572
DS-VD 12-S	418	DS-VSCHK 25-S	477	FLAT ARMOUR GUARD ID 1.219"	572
DS-VD 14-S	418	DS-VSCHK 28-L	477	FLAT ARMOUR GUARD ID 1.562"	572

Ref.	P.	Ref.	P.	Ref.	P.
FLAT ARMOUR GUARD ID 1.797"	572	FSR 18	544	FUEL MAS SD 127mm x CL40	93
FLAT ARMOUR GUARD ID 1"	572	FSR 18 L/S-1.4571	544	FUEL MAS SD 152mm x CL40	93
FLAT ARMOUR GUARD ID 2.093"	572	FSR 20	544	FUEL MAS SD 19mm x CL40	93
FLAT ARMOUR GUARD ID 2.343"	572	FSR 20 L/S-1.4571	544	FUEL MAS SD 19mm x CL61	93
FLAT ARMOUR GUARD ID 2.875"	572	FSR 22	544	FUEL MAS SD 25mm x CL40	93
FOW	543	FSR 22 L/S-1.4571	544	FUEL MAS SD 25mm x CL61	93
FOW 10X1-1,5L/S	544	FSR 25	544	FUEL MAS SD 32mm x CL40	93
FOW 10X2+L/S	544	FSR 25 L/S-1.4571	544	FUEL MAS SD 32mm x CL61	93
FOW 12X1-1,5L/S	544	FSR 28	544	FUEL MAS SD 38mm x CL40	93
FOW 12X2+L/S	544	FSR 28 L/S-1.4571	544	FUEL MAS SD 38mm x CL61	93
FOW 15X2+	544	FSR 30	544	FUEL MAS SD 50mm x CL40	93
FOW 16X2+	544	FSR 30 L/S-1.4571	544	FUEL MAS SD 51mm x CL40	93
FOW 18X2+	544	FSR 35	544	FUEL MAS SD 51mm x CL61	93
FOW 20X2,5+	544	FSR 35 L/S-1.4571	544	FUEL MAS SD 63mm x CL40	93
FOW 22X2+	544	FSR 38	544	FUEL MAS SD 75mm x CL40	93
FOW 25X2,5+	544	FSR 38 L/S-1.4571	544	FUEL MAS SD 76mm x CL40	93
FOW 28X2,5+	544	FSR 42	544	FUEL MAS SD 76mm x CL61	93
FOW 30X3+	544	FSR 42 L/S-1.4571	544	G 4-LL	389
FOW 35X2,5+	544	FSR 6 L/S-1.4571	544	G 6-LL	389
FOW 38X3+	544	FSR 6-L/S	544	G 8-LL	389
FOW 42X3+	544	FSR 8 L/S-1.4571	544	GM 10-S/12-L	475
FOW 6X1-1,5 L/S	544	FSR 8-L/S	544	GM 12-S	475
FOW 8X1-1,5 L/S	544	FSSR	543	GM 14-S/15-L	475
FOW 8X2+L/S	544	FSSR 10 L/S	544	GM 16-S	475
FP P20-D21	557	FSSR 10 L/S-1.4571	544	GM 18-L	475
FP P20-D22	557	FSSR 12 L/S	544	GM 20-S/22-L	475
FP P20-D33	557	FSSR 12 L/S-1.4571	544	GM 25-S/28-L	475
FP P20-D34	557	FSSR 6 L/S	544	GM 30-S	475
FP P20-D35	557	FSSR 6 L/S-1.4571	544	GM 35-L	475
FP P20-D37	557	FSSR 8 L/S	544	GM 38-S/42-L	475
FP P20-D39	557	FSSR 8 L/S-1.4571	544	GM 6-L	475
FP P32-D21	557	FUEL MAS D 100mm x CL40	92	GM 6-S/ 8-L	475
FP P32-D22	557	FUEL MAS D 102mm x CL40	92	GM 8-S/10-L	475
FP P32-D310	557	FUEL MAS D 102mm x CL61	92	GP MAS 10mm x CL60	118
FP P32-D311	557	FUEL MAS D 152mm x CL40	92	GP MAS 13mm x CL60	118
FP P32-D312	557	FUEL MAS D 19mm x CL40	92	GP MAS 16mm x CL60	118
FP P32-D313	557	FUEL MAS D 19mm x CL61	92	GP MAS 19mm x CL60	118
FP P32-D314	557	FUEL MAS D 25mm x CL40	92	GP MAS 25mm x CL60	118
FP P32-D33	557	FUEL MAS D 25mm x CL61	92	GP MAS 6mm x CL60	118
FP P32-D34	557	FUEL MAS D 32mm x CL40	92	GP MAS 8mm x CL60	118
FP P32-D35	557	FUEL MAS D 32mm x CL61	92	GP40 - 10mm	123
FP P32-D37	557	FUEL MAS D 38mm x CL40	92	GP40 - 13mm	123
FP P32-D39	557	FUEL MAS D 38mm x CL61	92	GP40 - 16mm	123
FS 93	543	FUEL MAS D 50mm x CL40	92	GP40 - 19mm	123
FSR	543	FUEL MAS D 51mm x CL40	92	GP40 - 25mm	123
FSR 10 L/S-1.4571	544	FUEL MAS D 51mm x CL61	92	GP40 - 32mm	123
FSR 10-L/S	544	FUEL MAS D 63mm x CL40	92	GP40 - 38mm	123
FSR 12 L/S-1.4571	544	FUEL MAS D 75mm x CL40	92	GP40 - 6mm	123
FSR 12-L/S	544	FUEL MAS D 76mm x CL40	92	GP40 - 8mm	123
FSR 15	544	FUEL MAS D 76mm x CL61	92	GP60 - 10mm	119
FSR 15 L/S-1.4571	544	FUEL MAS SD 100mm x CL40	93	GP60 - 13mm	119
FSR 16	544	FUEL MAS SD 102mm x CL40	93	GP60 - 16mm	119
FSR 16 L/S-1.4571	544	FUEL MAS SD 102mm x CL61	93	GP60 - 19mm	119

PRODUCT INDEX

INTEGRATED FLUID POWER SOLUTIONS

Ref.	P.	Ref.	P.	Ref.	P.
GP60 - 25mm	119	K4/K7/S5-D33	557	M 25-S	474
GP60 - 6mm	119	K4/K7/S5-D34	557	M 28-L	474
GP60 - 8mm	119	K4/K7/S5-D35	557	M 30-S	474
GP80+ - 10mm	115	K4/K7/S5-D37	557	M 35-L	474
GP80+ - 13mm	115	KDE M12	483	M 38-S	474
GP80+ - 16mm	115	KDE M14	483	M 42-L	474
GP80+ - 19mm	115	KDE M16	483	M 4-LL	474
GP80+ - 25mm	115	KDE M18	483	M 6-L	474
GP80+ - 32mm	115	KDE M20	483	M 6-LL	474
GP80+ - 38mm	115	KDE M22	483	M 6-S	474
GP80+ - 50mm	115	KDE R 1 1/2" / M48	483	M 8-L	474
GP80+ - 6mm	115	KDE R 1 1/4" / M42	483	M 8-LL	474
GP80+ - 8mm	115	KDE R 1" / M33	483	M 8-S	474
GR 4/8/4-LL	390	KDE R 1/2"	483	MC 1001-D21	556
GR 6/4/6-LL	390	KDE R 1/4"	483	MC 1001-D22	556
HEATER MAS 13mm x CL40	101	KDE R 1/8" / M10	483	MC 1001-D33	556
HEATER MAS 16mm x CL40	101	KDE R 3/4" / M26 / M27	483	MC 1001-D34	556
HEATER MAS 19mm x CL40	101	KDE R 3/8"	483	MC 1001-D35	556
HEATER MAS 25mm x CL40	101	LOLA+04	116	MC 1001-D37	556
HEATER MAS 32mm x CL40	101	LOLA+06	116	MC 1001-manual	556
HEATER MAS 38mm x CL40	101	LOLA+08	116	MC 1001-pneumatic	556
HEATER MAS 51mm x CL40	101	LOLA+10	116	MC5001-D21	557
HG14 NYLON SLEEVE	568	LOLA+12	116	MC5001-D22	557
HG16 NYLON SLEEVE	568	LOLB+04	116	MC5001-D310B	557
HG20 NYLON SLEEVE	568	LOLB+06	116	MC5001-D311	557
HG24 NYLON SLEEVE	568	LOLB+08	116	MC5001-D312	557
HG28 NYLON SLEEVE	568	LOLB+10	116	MC5001-D313	557
HG32 NYLON SLEEVE	568	LOLB+12	116	MC5001-D314B	557
HG38 NYLON SLEEVE	568	LOLC+04	116	MC5001-D33	557
HG42 NYLON SLEEVE	568	LOLC+06	116	MC5001-D34	557
HG46 NYLON SLEEVE	568	LOLC+08	116	MC5001-D35	557
HG64 NYLON SLEEVE	568	LOLC+10	116	MC5001-D37	557
HIGH-TEMP AIR INTAKE 1"	79	LOLC+12	116	MC5001-D39	557
HIGH-TEMP AIR INTAKE 1.1/2"	79	LOLG+04	116	MCX 20-manual	555
HIGH-TEMP AIR INTAKE 1.1/4"	79	LOLG+06	116	MCX 237-D311	556
HIGH-TEMP AIR INTAKE 1.3/8"	79	LOLG+08	116	MCX 237-D312	556
HIGH-TEMP AIR INTAKE 2"	79	LOLG+10	116	MCX 237-D313	556
HIGH-TEMP AIR INTAKE 2.1/2"	79	LOLG+12	116	MCX 237-D314	556
HIGH-TEMP AIR INTAKE 2.1/4"	79	LOLR+04	116	MCX 239-D21	556
HIGH-TEMP AIR INTAKE 2.3/4"	79	LOLR+06	116	MCX 239-D22	556
HIGH-TEMP AIR INTAKE 2.3/8"	79	LOLR+08	116	MCX 239-D310	556
HIGH-TEMP AIR INTAKE 3"	79	LOLR+10	116	MCX 239-D33	556
HIGH-TEMP AIR INTAKE 3.1/2"	79	LOLR+12	116	MCX 239-D34	556
HIGH-TEMP AIR INTAKE 3.1/4"	79	M 10-L	474	MCX 239-D35	556
HIGH-TEMP AIR INTAKE 3.3/4"	79	M 10-S	474	MCX 239-D37	556
HIGH-TEMP AIR INTAKE 3.3/8"	79	M 12-L	474	MCX 239-D39	556
HIGH-TEMP AIR INTAKE 4"	79	M 12-S	474	MCX 25-12V	554
HIGH-TEMP AIR INTAKE 4.1/2"	79	M 14-S	474	MCX 25-220V	554
HIGH-TEMP AIR INTAKE 5"	79	M 15-L	474	MCX 25-380V	554
HIGH-TEMP AIR INTAKE 7/8"	79	M 16-S	474	MCX 263-D21	556
ICL-24-32	191	M 18-L	474	MCX 263-D22	556
K4/K7/S5-D21	557	M 20-S	474	MCX 263-D33	556
K4/K7/S5-D22	557	M 22-L	474	MCX 263-D34	556

Ref.	P.	Ref.	P.	Ref.	P.
MCX 263-D35	556	OPTI	542	RI 1"WD - 1 1/2"	455
MCX 263-D37	556	OPTI/F	539	RI 1"WD - 1 1/4"	455
MCX 263-D39	556	PBEH 642	545	RI 1"WD - 3/4"	455
MCX 30-12V	553	PBEH 642 F	545	RI 1/2"WD - 1 1/4"	455
MCX 30-220V	553	PBM 642	545	RI 1/2"WD - 1"	455
MCX 30-380V	553	PLANT MAS 200 BLACK 1/2"	122	RI 1/2"WD - 1/8"	455
MCX 50-380V	552	PLANT MAS 200 BLACK 1/4"	122	RI 1/2"WD - 3/4"	455
MILK MAS SD 102mm x CL40	111	PLANT MAS 200 BLACK 1"	122	RI 1/2"WD - 3/8"	455
MILK MAS SD 38mm x CL40	111	PLANT MAS 200 BLACK 3/4"	122	RI 1/2"WD - 1/4"	455
MILK MAS SD 40mm x CL40	111	PLANT MAS 200 BLACK 3/8"	122	RI 1/2-1	454
MILK MAS SD 45mm x CL40	111	PLANT MAS 200 BLACK 5/8"	122	RI 1/2-1 1/4	454
MILK MAS SD 51mm x CL40	111	PLANT MAS XTRM 250 1 1/2"	121	RI 1/2-1/4	454
MILK MAS SD 63mm x CL40	111	PLANT MAS XTRM 250 1 1/4"	121	RI 1/2-1/8	454
MILK MAS SD 70mm x CL40	111	PLANT MAS XTRM 250 1/2"	121	RI 1/2-3/4	454
MILK MAS SD 76mm x CL40	111	PLANT MAS XTRM 250 1/4"	121	RI 1/2-3/8	454
MX 25-12V	550	PLANT MAS XTRM 250 1"	121	RI 1/4"WD - 1/2"	455
MX 25-220V	550	PLANT MAS XTRM 250 3/4"	121	RI 1/4"WD - 1/8"	455
MX 30-380V	549	PLANT MAS XTRM 250 3/8"	121	RI 1/4"WD - 3/4"	455
MX 40-380V	548	PLANT MAS XTRM 250 5/8"	121	RI 1/4"WD - 3/8"	455
MULTI MAS 10mm x CL100	120	RBV 6/18	546	RI 1/4-1/2	454
MULTI MAS 13mm x CL100	120	REEL MAS D 25mm x CL61	96	RI 1/4-1/8	454
MULTI MAS 16mm x CL50	120	REEL MAS D 32mm x CL61	96	RI 1/4-3/4	454
MULTI MAS 19mm x CL50	120	REEL MAS D 35mm x CL61	96	RI 1/4-3/8	454
MULTI MAS 25mm x CL50	120	REEL MAS D 38mm x CL61	96	RI 1/8"WD - 1/4"	455
MULTI MAS 32mm x CL30	120	REEL MAS D 40mm x CL61	96	RI 1/8"WD - 3/8"	455
MULTI MAS 38mm x CL30	120	REEL MAS D 51mm x CL61	96	RI 1/8-1/4	454
MULTI MAS 6mm x CL100	120	RF 1 1/2"	468	RI 1/8-3/8	454
MULTI MAS 8mm x CL100	120	RF 1 1/4"	468	RI 1-1 1/2	454
OG 642	559	RF 1"	468	RI 1-1 1/4	454
OIL MAS Lite SD 100mm x CL40	95	RF 1/2"	468	RI 1-1/2	454
OIL MAS Lite SD 127mm x CL40	95	RF 1/4"	468	RI 1-1/4	454
OIL MAS Lite SD 152mm x CL40	95	RF 1/8"	468	RI 1-3/4	454
OIL MAS Lite SD 19mm x CL40	95	RF 3/4"	468	RI 1-3/8	454
OIL MAS Lite SD 25mm x CL40	95	RF 3/8"	468	RI 3/4"WD - 1 1/2"	455
OIL MAS Lite SD 32mm x CL40	95	RI 1"WD - 1/2"	455	RI 3/4"WD - 1 1/4"	455
OIL MAS Lite SD 38mm x CL40	95	RI 1"WD - 1/4"	455	RI 3/4"WD - 1"	455
OIL MAS Lite SD 51mm x CL40	95	RI 1"WD - 3/8"	455	RI 3/4"WD - 1/2"	455
OIL MAS Lite SD 65mm x CL40	95	RI 1 1/2"WD - 1 1/4"	455	RI 3/4"WD - 1/4"	455
OIL MAS Lite SD 76mm x CL40	95	RI 1 1/2"WD - 1"	455	RI 3/4"WD - 3/8"	455
OIL MAS Lite SD 90mm x CL40	95	RI 1 1/2"WD - 1/2"	455	RI 3/4-1	454
OIL MAS SD 100mm x CL40	94	RI 1 1/2"WD - 3/4"	455	RI 3/4-1 1/2	454
OIL MAS SD 125mm x CL40	94	RI 1 1/2-1	454	RI 3/4-1 1/4	454
OIL MAS SD 152mm x CL40	94	RI 1 1/2-1 1/4	454	RI 3/4-1/2	454
OIL MAS SD 19mm x CL40	94	RI 1 1/2-1/2	454	RI 3/4-1/4	454
OIL MAS SD 25mm x CL40	94	RI 1 1/2-3/4	454	RI 3/4-3/8	454
OIL MAS SD 32mm x CL40	94	RI 1 1/4"WD - 1 1/2"	455	RI 3/8"- 1/8"	454
OIL MAS SD 38mm x CL40	94	RI 1 1/4"WD - 1"	455	RI 3/8"WD - 1/2"	455
OIL MAS SD 50mm x CL40	94	RI 1 1/4"WD - 1/2"	455	RI 3/8"WD - 1/4"	455
OIL MAS SD 65mm x CL40	94	RI 1 1/4"WD - 3/4"	455	RI 3/8"WD - 1/8"	455
OIL MAS SD 75mm x CL40	94	RI 1 1/4-1	454	RI 3/8"WD - 3/4"	455
OPT/A	541	RI 1 1/4-1 1/2	454	RI 3/8-1/2	454
OPT/E	542	RI 1 1/4-1/2	454	RI 3/8-1/4	454
OPT/F	539	RI 1 1/4-3/4	454	RI 3/8-3/4	454

PRODUCT INDEX

INTEGRATED FLUID POWER SOLUTIONS

Ref.	P.	Ref.	P.	Ref.	P.
RSG 1.1/8" GUARD	570	SNO 12x2,5	488	SNO-V-38x4-S/SA	490
RSG 1.11/32" GUARD	570	SNO 15x1,5	488	SNO-V-38x5-S/SA	490
RSG 1.27/32" GUARD	570	SNO 15x2	488	SNO-V-38x6-S/SA	490
RSG 1.3/64" GUARD	570	SNO 16x1,5	488	SNO-V-38x7-S/SA	490
RSG 1.37/64" GUARD	570	SNO 16x2	488	SNR 10/6x2	489
RSG 1.9/32" GUARD	570	SNO 16x2,5	488	SNR 10/8x2,5	489
RSG 2.7/64" GUARD	570	SNO 16x3	488	SNR 12/10x3	489
RSG 35/64" GUARD	570	SNO 18x2	488	SNR 12/8x2,5	489
RSG 43/64" GUARD	570	SNO 18x2,75	488	SNR 16/12x3,5	489
RSG 47/64" GUARD	570	SNO 20x2	488	SNR 20/12x3,5	489
RSG 55/64" GUARD	570	SNO 20x2,5	488	SNR 20/16x3	489
RSG 59/64" GUARD	570	SNO 20x3	488	SNR 25/16x3	489
RSG 63/64" GUARD	570	SNO 20x4	488	SNR 25/20x4	489
S 4-LL	472	SNO 22x2	488	SNR 30/16x3	489
S 6-LL	472	SNO 22x2,5	488	SNR 30/20x4	489
S 8-LL	472	SNO 22x3	488	SNR 30/25x5	489
SANDBLAST MAS D 19mm x CL40	125	SNO 25x3	488	SNR 38/16x3	489
SANDBLAST MAS D 25mm x CL40	125	SNO 25x4	488	SNR 38/20x4	489
SANDBLAST MAS D 32mm x CL40	125	SNO 25x5	488	SNR 38/25x5	489
SANDBLAST MAS D 38mm x CL40	125	SNO 28x2,5	488	SNR 38/30x4	489
SBD 4-MLL	401	SNO 28x3	488	SPW	543
SBD 4-MLL	403	SNO 30x3	488	SPW 10L/S	544
SBD 4-RLL	400	SNO 30x4	488	SPW 12L/S	544
SBD 4-RLL	402	SNO 30x5	488	SPW 15L/S	544
SBD 6-MLL	401	SNO 30x6	488	SPW 16L/S	544
SBD 6-MLL	403	SNO 35x3	488	SPW 18L/S	544
SBD 6-RLL	400	SNO 38x4	488	SPW 20L/S	544
SBD 6-RLL	402	SNO 38x5	488	SPW 22L/S	544
SBD 8-MLL	401	SNO 38x6	488	SPW 25L/S	544
SBD 8-MLL	403	SNO 38x7	488	SPW 28L/S	544
SBD 8-RLL	400	SNO 42x3	488	SPW 30L/S	544
SBD 8-RLL	402	SNO 42x4	488	SPW 35L/S	544
SILO MAS D - 102mm x CL40	128	SNO-V-10x1,5-S/SA	490	SPW 38L/S	544
SILO MAS D - 110mm x CL40	128	SNO-V-10x1-S/SA	490	SPW 42L/S	544
SILO MAS D - 51mm x CL40	128	SNO-V-10x2-S/SA	490	SPW 6L/S	544
SILO MAS D - 63mm x CL40	128	SNO-V-12x1,5-S/SA	490	SPW 8L/S	544
SILO MAS D - 76mm x CL40	128	SNO-V-12x2,5-S/SA	490	SRO 6-L/S	495
SILO MAS D - 80mm x CL40	128	SNO-V-12x2-S/SA	490	SRO 8-L/S	495
SILO MAS D - 90mm x CL40	128	SNO-V-16x1,5-S/SA	490	SRO 10-L/S	495
SILO MAS SD - 102mm x CL40	129	SNO-V-16x2,5-S/SA	490	SRO 12-L/S	495
SILO MAS SD - 110mm x CL40	129	SNO-V-16x2-S/SA	490	SRO 14-S	495
SILO MAS SD - 152mm x CL40	129	SNO-V-16x3-S/SA	490	SRO 15-L	495
SILO MAS SD - 203mm x CL40	129	SNO-V-20x2,5-S/SA	490	SRO 16-S	495
SILO MAS SD - 51mm x CL40	129	SNO-V-20x2-S/SA	490	SRO 18-L	495
SILO MAS SD - 63mm x CL40	129	SNO-V-20x3-S/SA	490	SRO 20-S	495
SILO MAS SD - 76mm x CL40	129	SNO-V-20x4-S/SA	490	SRO 22-L	495
SILO MAS SD - 80mm x CL40	129	SNO-V-25x3-S/SA	490	SRO 25-S	495
SILO MAS SD - 90mm x CL40	129	SNO-V-25x4-S/SA	490	SRO 28-L	495
SNO 10x1	488	SNO-V-25x5-S/SA	490	SRO 30-S	495
SNO 10x1,5	488	SNO-V-30x3-S/SA	490	SRO 35-L	495
SNO 10x2	488	SNO-V-30x4-S/SA	490	SRO 38-S	495
SNO 12x1,5	488	SNO-V-30x5-S/SA	490	SRO 42-L	495
SNO 12x2	488	SNO-V-30x6-S/SA	490	STEAM MAS 13mm x CL40	99

Ref.	P.	Ref.	P.	Ref.	P.
STEAM MAS 16mm x CL40	99	TPM 06	545	VM 8-L	540
STEAM MAS 19mm x CL40	99	TPM 08	545	VM 8-S	540
STEAM MAS 25mm x CL40	99	TPM 10	545	VM 10-L	540
STEAM MAS 32mm x CL40	99	TPM 12	545	VM 10-S	540
STEAM MAS 38mm x CL40	99	TPM 14	545	VM 12-L	540
STEAM MAS 51mm x CL40	99	TPM 15	545	VM 12-S	540
STEAM MAS RED 13mm x CL40	100	TPM 16	545	VM 14-S	540
STEAM MAS RED 16mm x CL40	100	TPM 18	545	VM 15-L	540
STEAM MAS RED 19mm x CL40	100	TPM 20	545	VM 16-S	540
STEAM MAS RED 25mm x CL40	100	TPM 22	545	VM 18-L	540
STEAM MAS RED 32mm x CL40	100	TPM 25	545	VM 20-S	540
STEAM MAS RED 38mm x CL40	100	TPM 28	545	VM 22-L	540
STEAM MAS RED 51mm x CL40	100	TPM 30	545	VM 25-S	540
STO 6-L/S/O	478	TPM 35	545	VM 28-L	540
STO 8-L/S/O	478	TPM 38	545	VM 30-S	540
STO 10-L/S/O	478	TPM 42	545	VM 35-L	540
STO 12-L/S/O	478	TR 6-L/S	482	VM 38-S	540
STO 14-S/O	478	TR 8-L/S	482	VM 42-L	540
STO 15-L/O	478	TR 10-L/S	482	VO-1/2	523
STO 16-S/O	478	TR 12-L/S	482	VO-1/2-1/4	523
STO 18-L/O	478	TR 14-S	482	VO-1/4	523
STO 20-S/O	478	TR 15-L	482	VO-1/4-1/2	523
STO 22-L/O	478	TR 16-S	482	VSCH-M 12x1,5/WD	476
STO 25-S/O	478	TR 18-L	482	VSCH-M 14x1,5/WD	476
STO 28-L/O	478	TR 20-S	482	VSCH-M 16x1,5/WD	476
STO 30-S/O	478	TR 22-L	482	VSCH-M 18x1,5/WD	476
STO 35-L/O	478	TR 25-S	482	VSCH-M 20x1,5/WD	476
STO 38-S/O	478	TR 28-L	482	VSCH-M 22x1,5/WD	476
STO 42-L/O	478	TR 30-S	482	VSCH-M 26x1,5/WD	476
TAR MAS SD 102mm x CL40	98	TR 35-L	482	VSCH-M 27x2/WD	476
TAR MAS SD 25mm x CL40	98	TR 38-S	482	VSCH-M 33x2/WD	476
TAR MAS SD 32mm x CL40	98	TR 42-L	482	VSCH-M 42x2/WD	476
TAR MAS SD 38mm x CL40	98	TS04	349	VSCH-M 48x2/WD	476
TAR MAS SD 51mm x CL40	98	TS05	349	VSCH-M10x1/WD	476
TAR MAS SD 63mm x CL40	98	TS06	349	VSCH-R 1"/WD	476
TAR MAS SD 76mm x CL40	98	TS08	349	VSCH-R 1/2"/WD	476
TC 080/220V	547	TS10	349	VSCH-R 1/4"/WD	476
TC 080/380V	547	TS12	349	VSCH-R 1/8"/WD	476
TC 1036 S	560	TS16	349	VSCH-R 3/4"/WD	476
THERMOPL. ARMOUR GUARD 1710.95	574	UE S 10-L	475	VSCH-R 3/8"/WD	476
THERMOPL. ARMOUR GUARD 1712.95	574	UE S 12-L	475	VSCH-R 11/2"/WD	476
THERMOPL. ARMOUR GUARD 1714.95	574	UE S 4-LL	475	VSCH-R 11/4"/WD	476
THERMOPL. ARMOUR GUARD 1722.95	574	UE S 6-L	475	VSH 6x0,5	485
TPG	545	UE S 6-LL	475	VSH 6x0,75	485
TPG 6/ 8	545	UE S 8-L	475	VSH 6x1	485
TPG 10/12	545	UE S 8-LL	475	VSH 8x0,5/10x1,5	485
TPG 14/16	545	UNI-BB	542	VSH 8x1	485
TPG 18/20	545	UNI-BB0	542	VSH 10x1	485
TPG 22/25	545	UP 3	542	VSH 12x1	485
TPG 28/30	545	UP/M	541	VSH 12x1,5	485
TPG 35/38	545	UPM622	540	VSH 14x1/15x1,5	485
TPG 42	545	VM 6-L	540	VSH 15x1/16x1,5	485
TPM	545	VM 6-S	540	VSH 16x1/18x2	485

PRODUCT INDEX

INTEGRATED FLUID POWER SOLUTIONS

Ref.	P.	Ref.	P.
VSH 18x1,5	485	WATER MAS SD 63mm x CL61	114
VSH 18x1/20x2	485	WATER MAS SD 76mm x CL40	114
VSH 20x1,5	485	WATER MAS SD 76mm x CL61	114
VSH 20x1/22x2	485	WD M 12 x 1,5 / ...	481
VSH 22x1,5	485	WD M 16 x 1,5 / ...	481
VSH 22x1/25x2,5	485	WD M 18 x 1,5 / ...	481
VSH 25x1,5	485	WD M 20 x 1,5 / ...	481
VSH 25x2	485	WD M 22 x 1,5 / ...	481
VSH 28x1,5	485	WD M 8 x 1 / ...	481
VSH 28x1/30x2	485	WD R 1/2" / ...	481
VSH 28x2	485	WD R 1/4" / M 14 x 1,5 / ...	481
VSH 35x1,5	485	WD R 1/8" / M 10 x 1 / ...	481
VSH 35x2	485	WD R 1" / M 33 x 2 / ...	481
VSH 35x2,5	485	WD R 1 1/2" / M 48 x 2 / ...	481
VSH 38x2,5	485	WD R 1 1/4" / M 42 x 2 / ...	481
VSH 42x2	485	WD R 3/4" / M 26 / M 27 / ...	481
WASHDOWN MAS 10mm x CL40	110	WD R 3/8" / ...	481
WASHDOWN MAS 13mm x CL40	110	X RVS 10-L/12-S	468
WASHDOWN MAS 16mm x CL40	110	X RVS 12-L/14-S	468
WASHDOWN MAS 19mm x CL40	110	X RVS 15-L/16-S	468
WASHDOWN MAS 25mm x CL40	110	X RVS 18-L/20-S	468
WASHDOWN MAS 32mm x CL40	110	X RVS 22-L/25-S	468
WASHDOWN MAS 38mm x CL40	110	X RVS 28-L/30-S	468
WASHDOWN MAS 51mm x CL40	110	X RVS 35-L/38-S	468
WATER MAS D 102mm x CL40	113	X RVS 6-L/5/8-S	468
WATER MAS D 102mm x CL61	113	X RVS 8-L/10-S	468
WATER MAS D 127mm x CL40	113		
WATER MAS D 152mm x CL40	113		
WATER MAS D 203mm x CL40	113		
WATER MAS D 25mm x CL40	113		
WATER MAS D 25mm x CL61	113		
WATER MAS D 32mm x CL40	113		
WATER MAS D 32mm x CL61	113		
WATER MAS D 38mm x CL40	113		
WATER MAS D 51mm x CL40	113		
WATER MAS D 51mm x CL61	113		
WATER MAS D 63mm x CL40	113		
WATER MAS D 63mm x CL61	113		
WATER MAS D 76mm x CL40	113		
WATER MAS SD 102mm x CL40	114		
WATER MAS SD 102mm x CL61	114		
WATER MAS SD 127mm x CL40	114		
WATER MAS SD 152mm x CL40	114		
WATER MAS SD 203mm x CL40	114		
WATER MAS SD 25mm x CL40	114		
WATER MAS SD 25mm x CL61	114		
WATER MAS SD 32mm x CL40	114		
WATER MAS SD 32mm x CL61	114		
WATER MAS SD 38mm x CL40	114		
WATER MAS SD 38mm x CL61	114		
WATER MAS SD 51mm x CL40	114		
WATER MAS SD 51mm x CL61	114		
WATER MAS SD 63mm x CL40	114		

WARNING

INTEGRATED FLUID POWER SOLUTIONS

Hydraulic fluid under pressure is potentially dangerous!

Serious injury, death and destruction of property can result from the rupture or other failure of a hose assembly that is:

- › damaged or worn out;
- › assembled or installed incorrectly.

Protect yourself and others.

- › Ensure you are properly trained in the use of Gates hose, couplings and assembly equipment.
- › Use correct crimp information. Ensure your assembly equipment is properly maintained and calibrated.
- › Use only (unused) Gates hose and coupling products and Gates assembly equipment. Never mix products from different manufacturers.
- › Use safety glasses and safety protection.

Hose selection and installation.

- › Basic notes and advice are included in this publication.
- › Consult Gates Safe Hydraulics Manual (E2/50092) for detailed selection and installation advice.

Regularly inspect hose assemblies for defects or signs of wear or ageing.

Product life will be influenced by:

- › severity of application;
- › frequency of equipment use.

Avoid injury.

- › Always position a shield between yourself and any pressurised hydraulic lines when working close to hydraulic systems - or shut off the pressure.
- › Never touch or work on pressurised hydraulics or hose assemblies.
- › Do not use hands to check for leaks.
- › Stay out of hazardous areas, including machine operating areas, when testing hose assemblies.
- › Remember that some hydraulic fluids are highly flammable.

If an injury occurs, particularly one where hydraulic fluid may have punctured the skin, seek medical assistance immediately.

Nominal dimensions.

All dimensions are nominal, do not use for inspection. We reserve the right to amend dimensions without notice. Please consult your Gates price list for product stock classification.

Caution!

Gates recommends only those hose and coupling combinations specified in the Gates hydraulic products catalogues. Gates disclaims all liability for any hose assemblies which have not been produced in conformance with Gates assembly recommendations and correct crimp data charts, or are incorrectly installed. Extensive testing has been done to verify the recommendations shown. Evaluation of a hose and coupling combination requires extensive impulse testing and cannot be determined by a simple burst or pressure hold test.

Any claim for defects must follow the RR (Return Report) procedure (information from your sales coordinator), to enable Gates to assess, report and act upon any alleged defect.



Hose Shelf Life

Hose and hose assemblies in storage can deteriorate to the point where they fail immediately or prematurely after being taken out of storage. The storage conditions, along with the rubber materials, can change the shelf life limit. Some hose materials such as EPDM have a tendency to last longer in storage due to the inherent resistance characteristics of the material. But there are many more variables affecting hose storage, making hose shelf life a value that is hard to quantify.

Standards SAE J517, SAE J1273, BS 5244, ISO 2230 and ISO 8331 provide guidelines for hose storage and age control. Refer to these specifications, and note that some storage precautions can support in the optimum shelf life.

Stored hose and hose assemblies must not be subjected to damage that could reduce their expected service life and must be placed in a cool, dark and dry area with the ends capped. Stored hose and hose assemblies must not be exposed to temperature extremes, ozone, oils, corrosive liquids or fumes, solvents, high humidity, rodents, insects, ultraviolet light, electromagnetic fields or radioactive materials.

The storage period should be kept to a minimum, rotation of stock is therefore essential. Hose and hose assemblies must be stored in a manner that facilitates age control and first-in and first-out usage based on manufacturing date of the hose and hose assemblies. Before fitting, all hose assemblies should be subjected to visual examination for evidence of deterioration. The shelf life of rubber Hydraulic hose or Hydraulic hose assemblies that have passed visual inspection follow below recommendation scheme from the date of manufacture. The shelf life of thermoplastic Hydraulic hose or hose assemblies is considered to be unlimited. For non-hydraulic hose applications such as engine hoses and industrial hoses Gates shelf life recommendation is set at maximum 8 years from the date of manufacture.

Test recommendations for hoses	
Age	Recommendations
Up to 3 years	Use without further testing
3 to 5 years	Use after representative samples subjected to a proof pressure test
5 to 8 years	Use after representative samples subjected to proof, impulse and burst pressure tests, and cold bend and electrical tests
Over 8 years	Scrap

NOTES

INTEGRATED FLUID POWER SOLUTIONS

A series of horizontal dotted lines for taking notes.



A series of horizontal dotted lines for writing, spanning the width of the page.



POWERING PROGRESS™

HEADQUARTERS BELGIUM

GATES EUROPE BVBA

Korte Keppestraat 21/51
9320 Erembodegem
T (32) 53 76 27 11 / F (32) 53 76 27 93

CZECH REPUBLIC

GATES HYDRAULICS S.R.O.

B.P. 37
Detmarovická 409/1
73301 Karviná - Stare Mesto
T (420) 597 467 611 / F (420) 597 467 612

FRANCE

GATES SERVICE CENTER S.A.S.

21 bvd Monge B.P. 14
69881 Meyzieu Cedex
T (33) 4 72 45 12 12 / F (33) 4 72 02 85 24

GERMANY

GATES EMB

Eifeler Maschinenbau GmbH
Kolumbusstraße 54
53881 Euskirchen
T (49) 2251 1256 0 / F (49) 2251 1256 400

UNITED KINGDOM

GATES HYDRAULICS

5 Alpha Drive
Eaton Socon
St Neots, Cambridgeshire
PE19 8JJ
T (44) 1480 40 23 84 / F (44) 1480 40 23 50

Gates.com/europe

Your distributor:

E2/50080

The manufacturers reserve the right to amend details where necessary.

© Gates Corporation 2015

Printed in Belgium - 12/15.